

TITANIC

BOOK 1

Booklet available in English on
Heft in deutscher Sprache erhältlich auf
Livret disponible en français sur
Libretto disponibile in Italiano su
Folleto disponible en español en
如需中文版手册，请访问

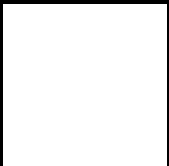

→ A White Star Line postcard depicting the Titanic.

THE QUEEN OF THE OCEANS

When the RMS *Titanic* left the port of Southampton, England, on 10 April 1912, on her maiden voyage bound for New York City, she was not only the largest ship afloat at the time but also the most luxurious. She was the second of three state-of-the-art Olympic-class ocean liners commissioned by the White Star Line in an effort to maintain the company's dominant position in the highly competitive trans-Atlantic passenger route. The Belfast-based shipbuilders, Harland and Wolff, had been authorised to spend what was needed to ensure the *Titanic* had a level of comfort and luxury never seen before.

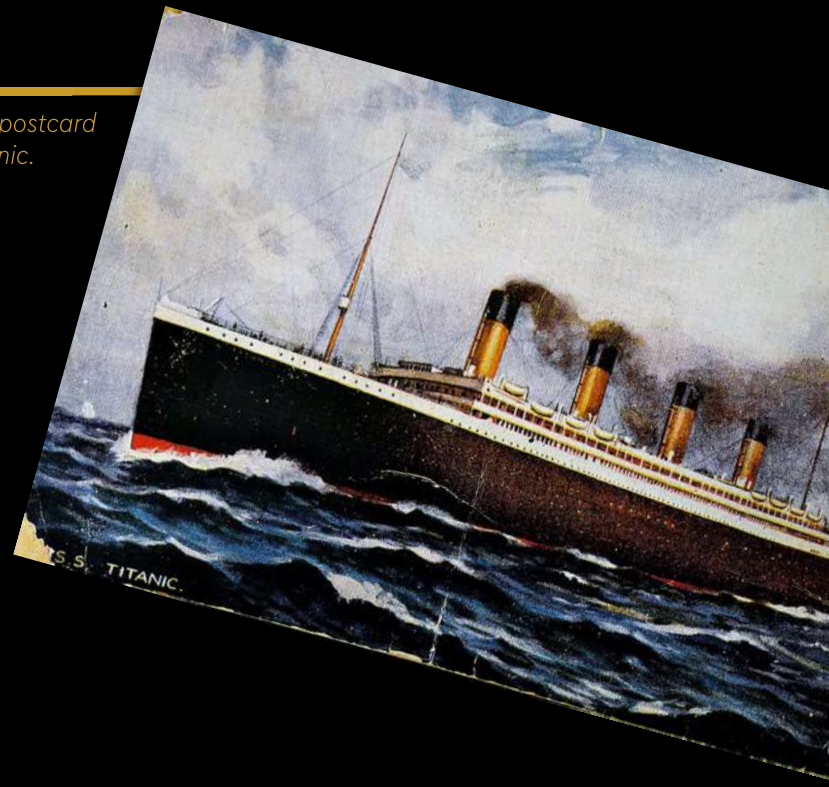



↑ The RMS Titanic departing
Southampton on 10 April 1912.

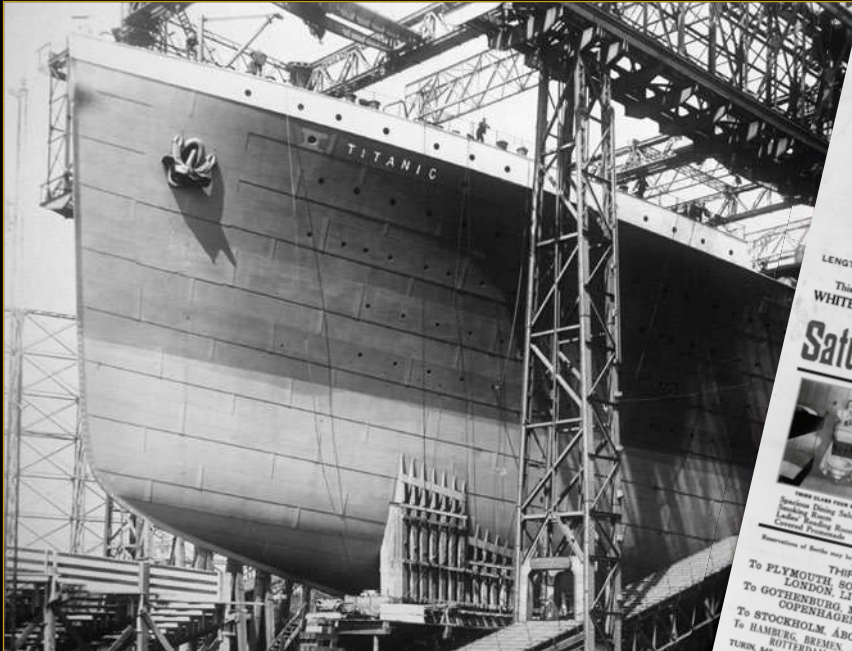

↑ The prow of the Titanic under construction at Harland and Wolff shipyard in Belfast, Ireland.

WHITE STAR LINE
 ROYAL & UNITED STATES MAIL STEAMERS
 FIRST SAILING OF THE LATEST ADDITION TO THE WHITE STAR FLEET
 The Queen of the Ocean
TITANIC

LENGTH 852 FT. OVER 45,000 TONS TRIPLE-SCREWS BEAM 92 FT.
 This, the Largest and Finest Steamer Afloat, will sail from
WHITE STAR LINE, PIER 59 (North River), NEW YORK
Saturday, April 20th At 12 Noon

THIRD CLASS FOUR DECK ROOM
 Spectacular Dining Saloons
 Smoking Room
 Ladies' Smoking Room
 General Promenade

All passengers berthed in closed rooms
 containing 2, 3, or 4 berths, a large room
 ber equipped with washstands, etc.

THIRD CLASS DINING SALOON

Remuneration of Berths may be made direct with the Office or through any of our accredited Agents

THIRD CLASS RATES ARE:
 To PLYMOUTH SOUTHAMPTON
 LONDON, LIVERPOOL and GLASGOW.
 To GOTHENBURG, MALMO, CHRISTIANIA,
 COPENHAGEN, ESBJERG, Etc. **\$36.25**
 To STOCKHOLM, ABO, HANGO, HELSINGFORS,
 To HAMBURG, BREMEN, ANTWERP, AMSTERDAM, **41.50**
 ROTTERDAM, HAVRE, CHERBOURG, **44.50**
 TURIN, BARI, NAPLES, BRINDISI, PIRAEUS, ETC. **45.00**
 BEYROUTH, SUEZ, ETC.

DO NOT DELAY. Passage and other charges through the local Agents or direct from
WHITE STAR LINE, 9 Broadway, New York
TICKETS FOR SALE HERE

← 1912: An advertisement for the luxury passenger liner Titanic, announcing the time of the ship's maiden voyage departure. Ticket prices and berth descriptions are provided.



→ Two White Star Liners, RMS Titanic and RMS Olympic, seen together for the last time, 3 February 1912.

THE TRIPLE SCREW OLYMPIC-CLASS LINER

The *Titanic* was powered by three powerful engines, each driving its own propeller. The two outer steam engines were 19 meters (63 ft.) long, weighed 720 tonnes (793.6 US tons) and created a combined output of 30,000 hp. The central, low-pressure turbine added a further 16,000 hp. It took 29 boilers, 484.5 tonnes (534.6 US tons) of water and 600 tonnes (661.3 US tons) of coal a day to power the steam engines. All three engines connected directly to propellers via long shafts. The two outer propellers were a massive 7.2 meters (23.5 ft.) in diameter, while the smaller middle one had a diameter of 5.2 meters (17 ft.) All this power gave the *Titanic* a top speed of 23 knots (more than 26 miles per hour).

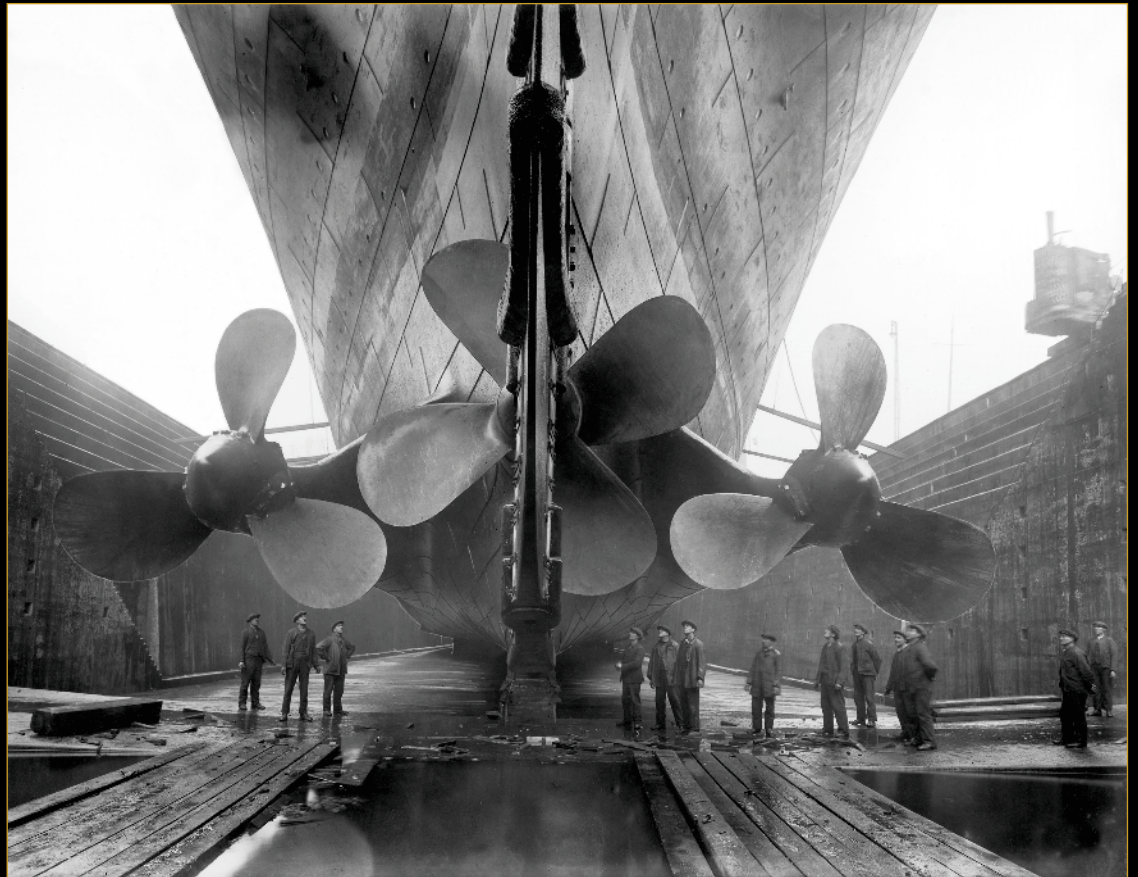

↑ The huge propellers of the RMS Titanic as the mighty ship sat in dry dock.



LEGO.com/brickseparator



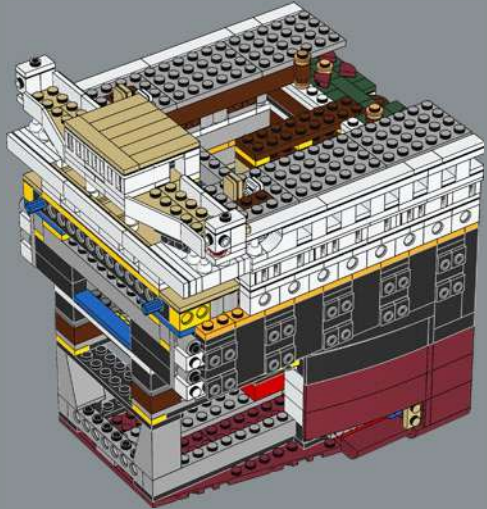
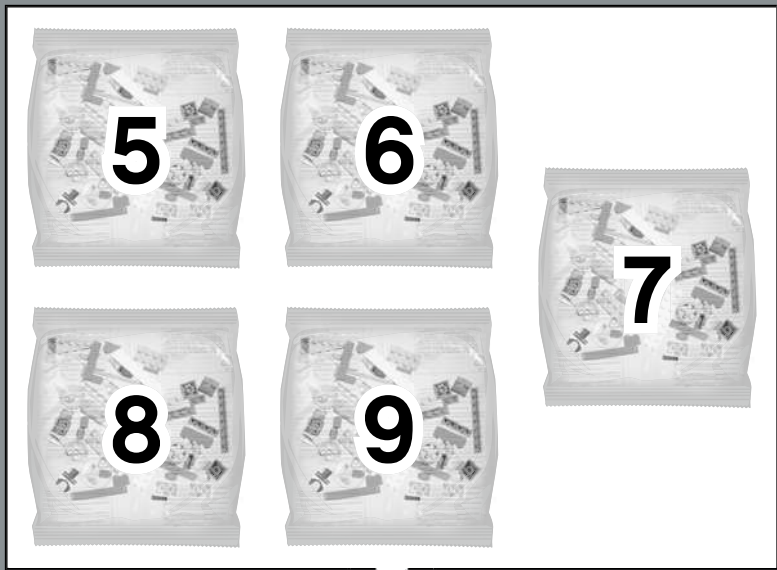

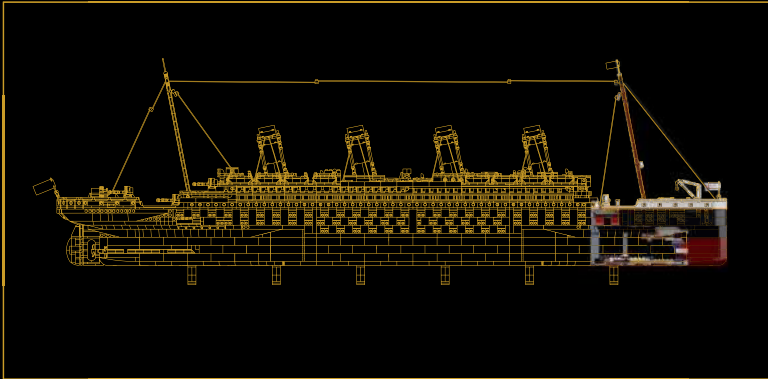

SECTION 1:

BOW AND WELL DECK

In this section you will build the bow of the ship along with the anchors, ship name, well deck, cargo hatches and cargo cranes, anchor crane with the 3rd anchor, and forward mast. In the interior of the ship the structures that will support the angled forward hull are also constructed. These will combine with supports in later sections to lock together and finish off the front hull of the model.

↓ We use the 2x10x2 triple curved bow brick to form the front of the keel of the model.



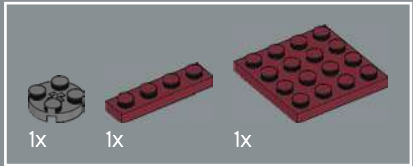
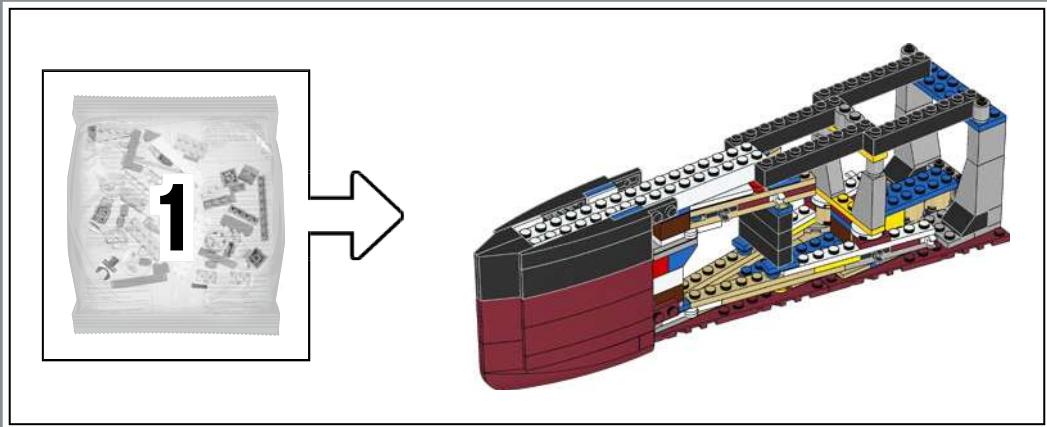

2

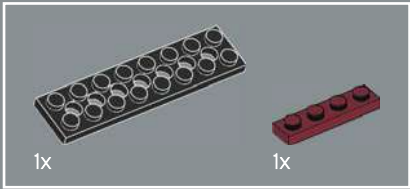

1

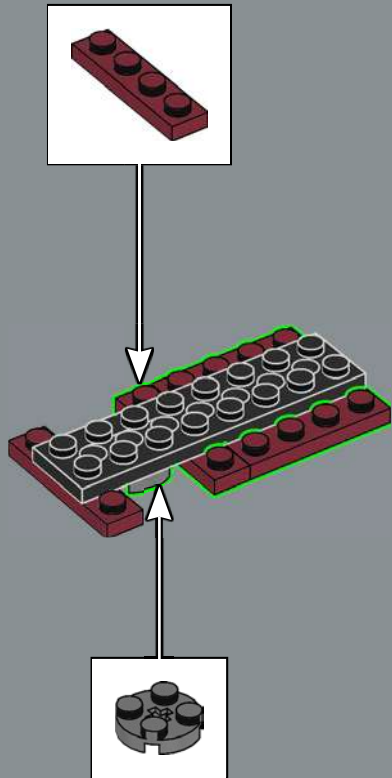
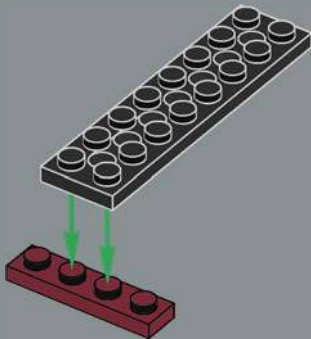

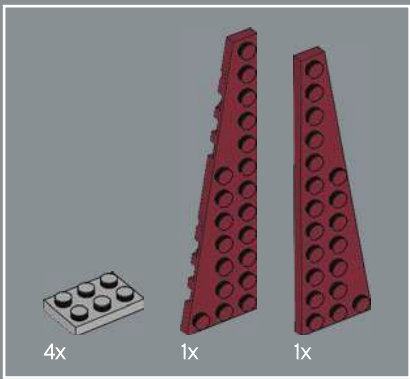

3

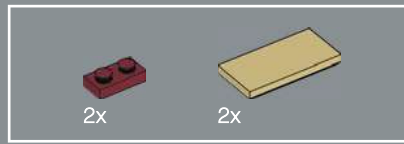
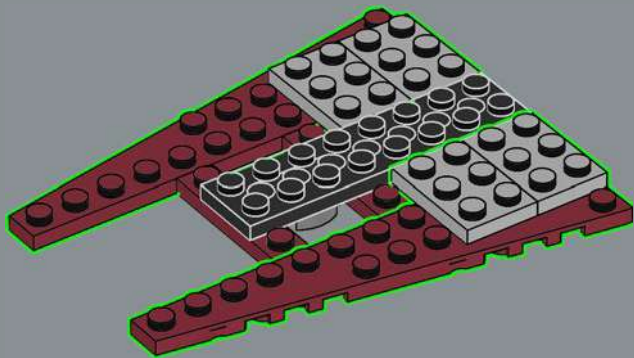

4

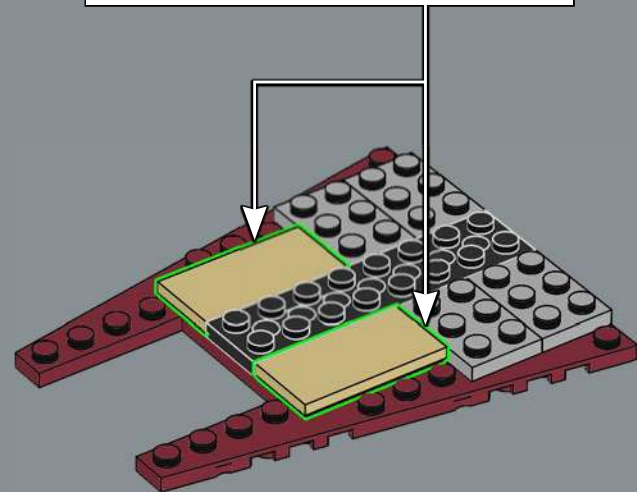
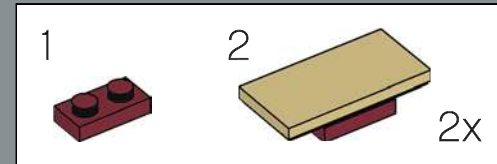

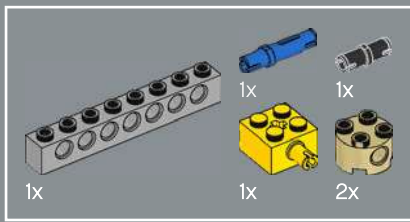

5

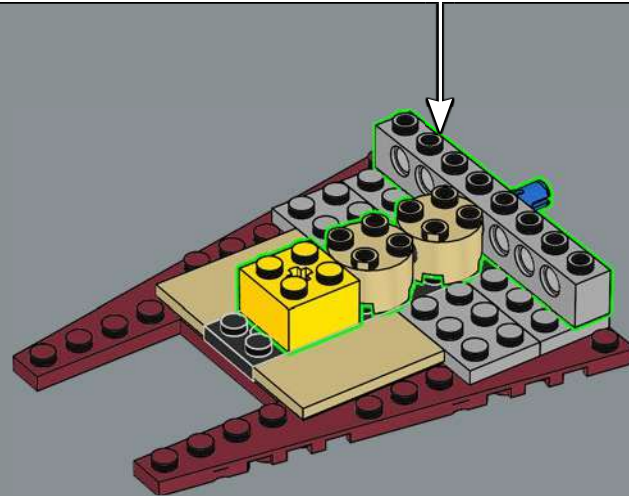
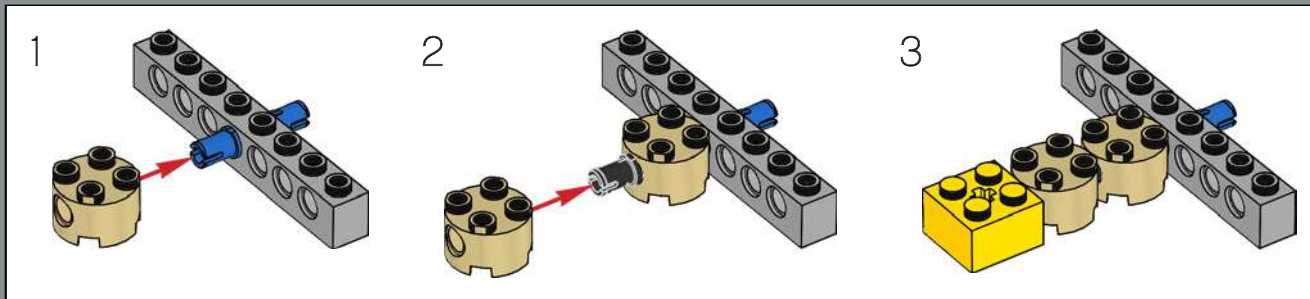

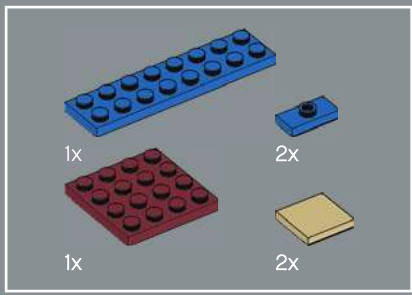

6

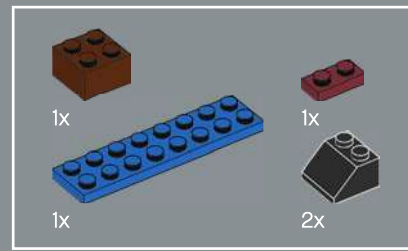
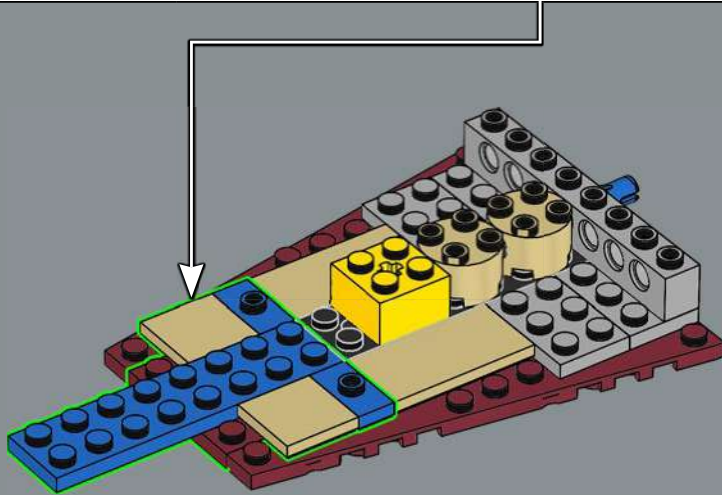
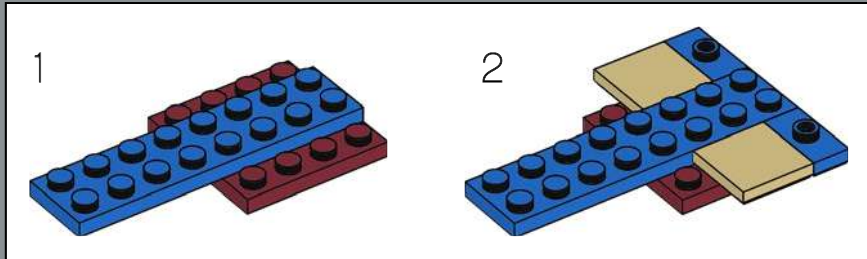

7

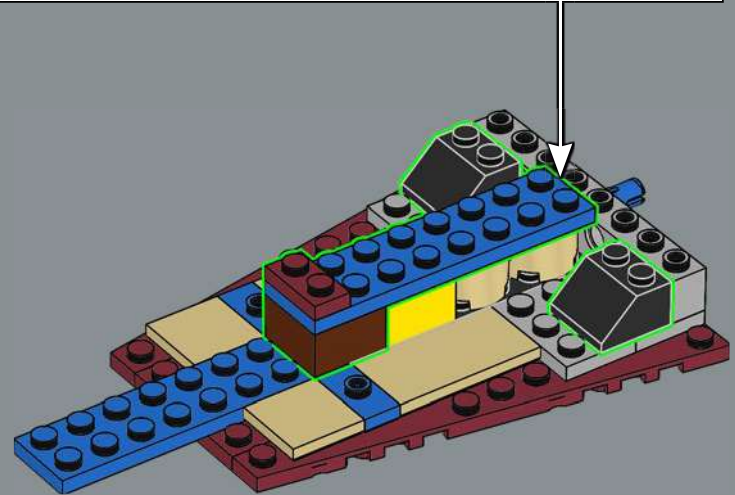
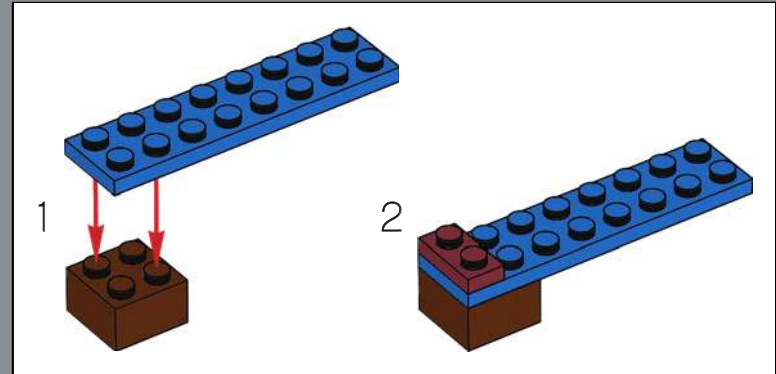

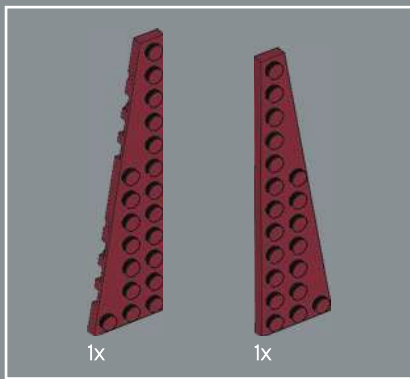

8

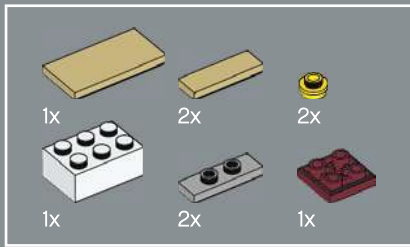
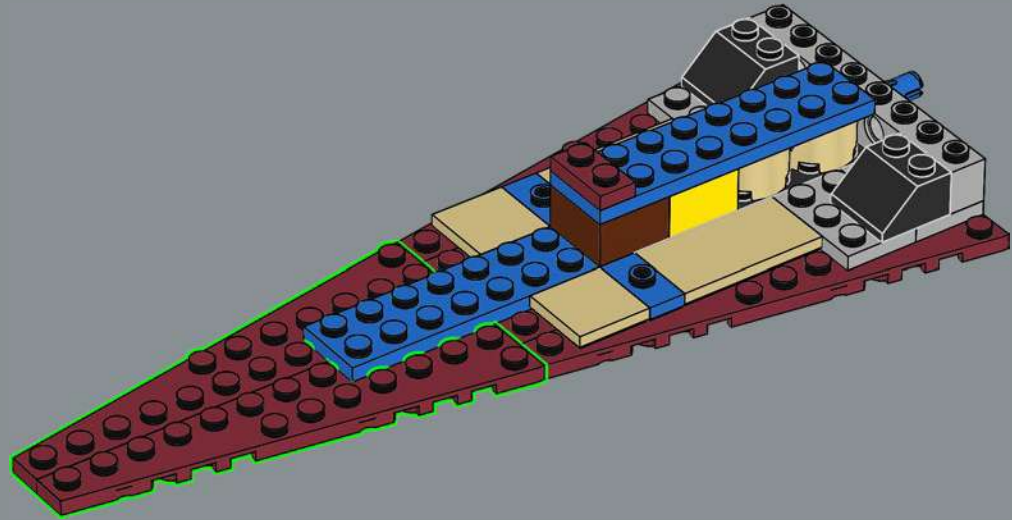

9

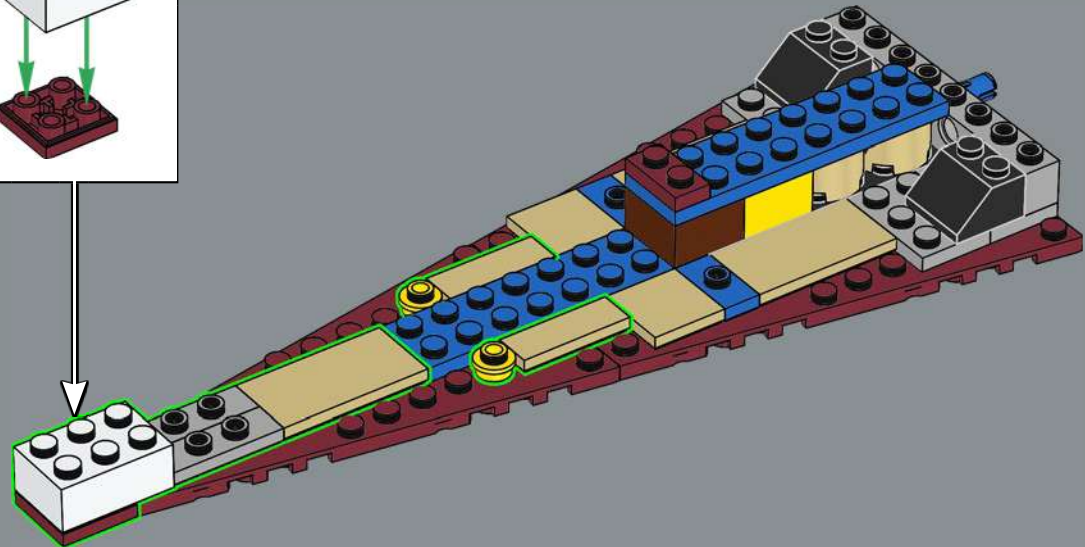
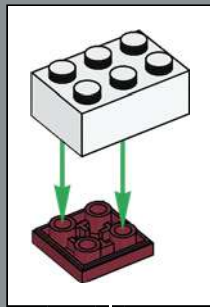

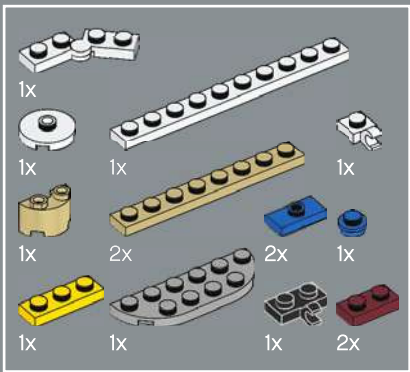

10

1

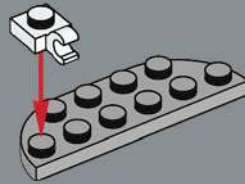

2

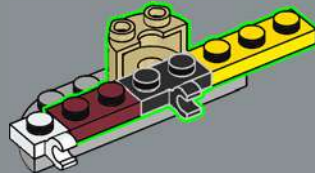

3

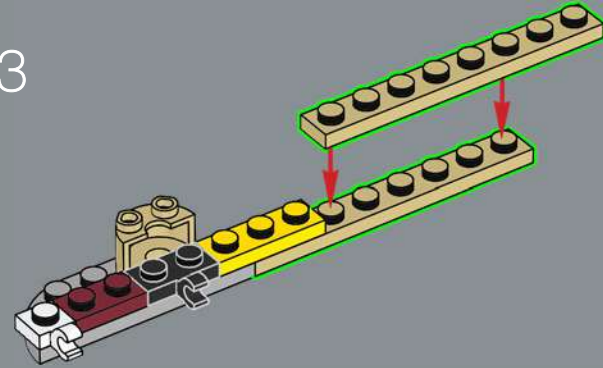

4

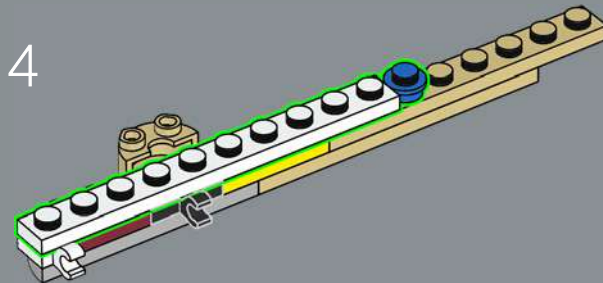

5

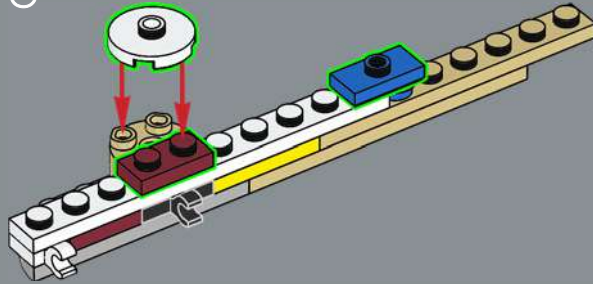

6

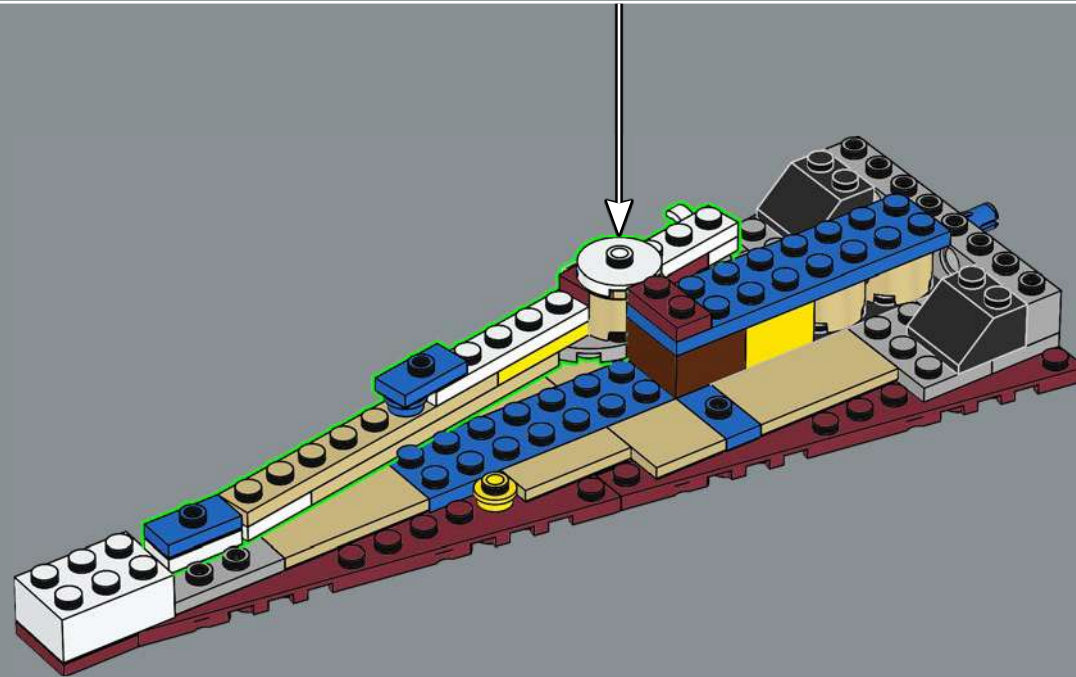
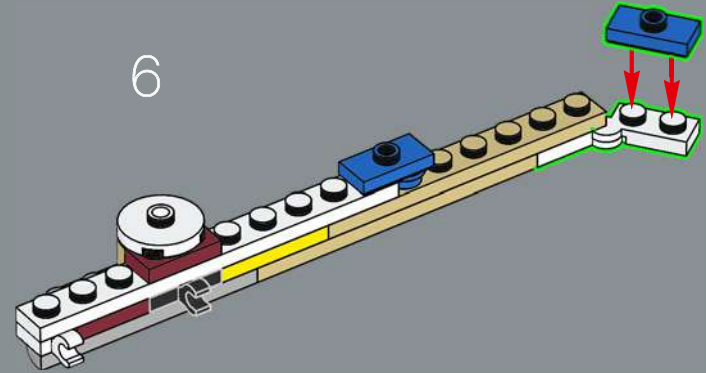

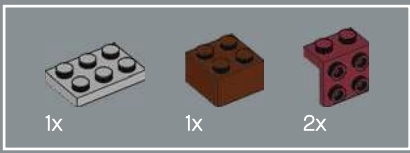

12

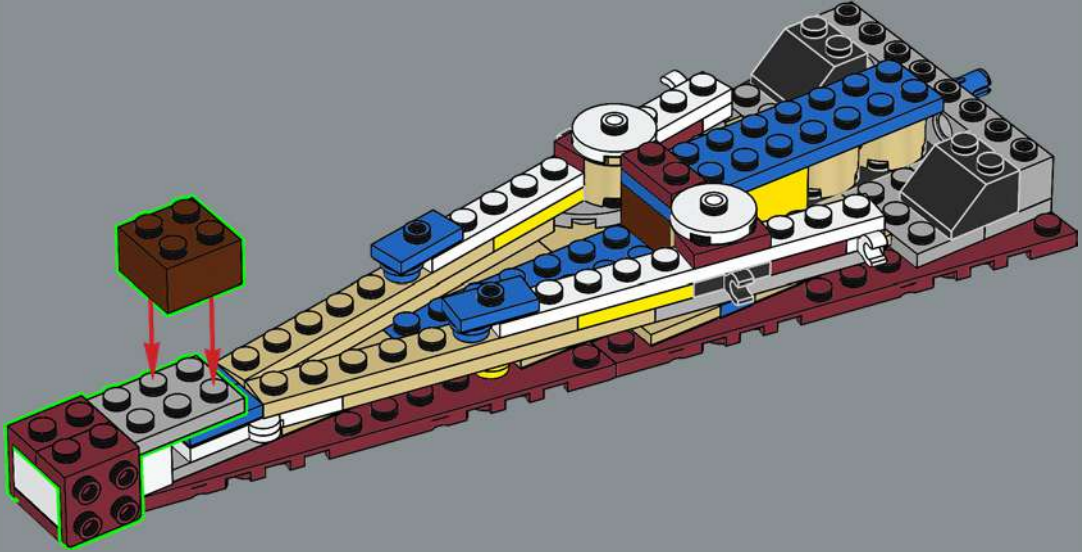

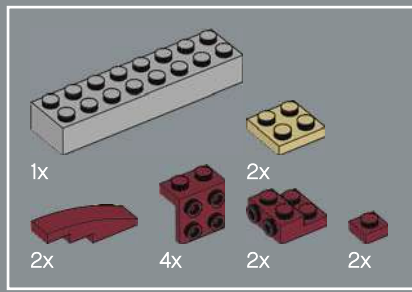

13

1

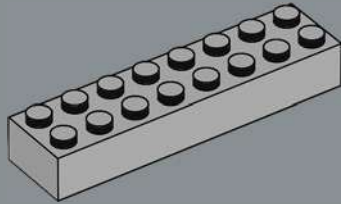

2

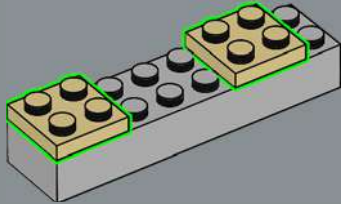

3

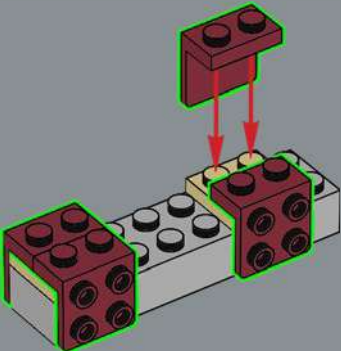

4

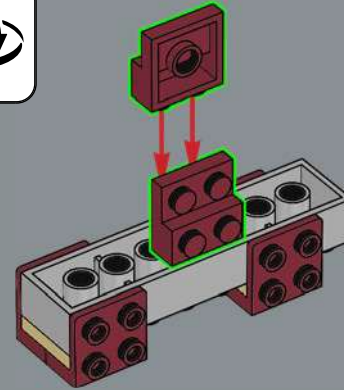

5

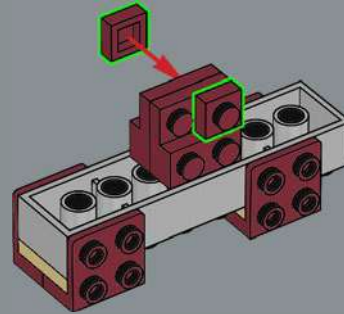

6

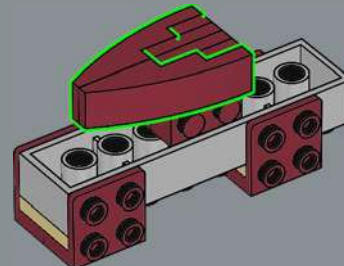

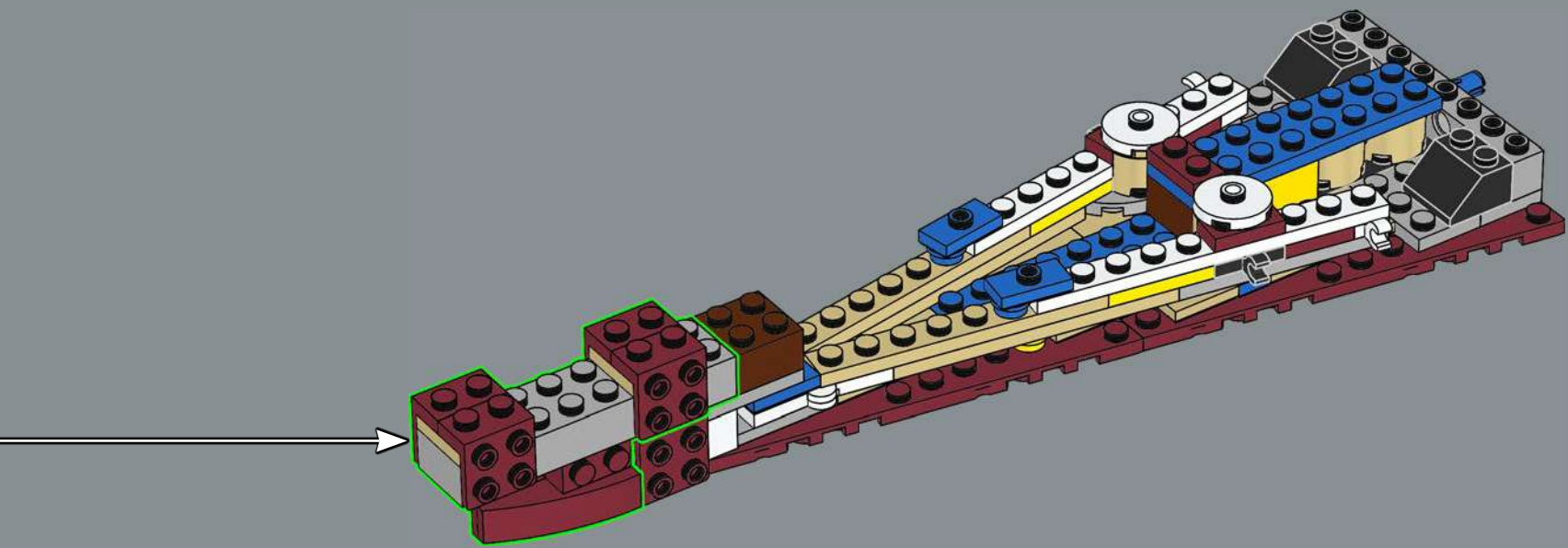

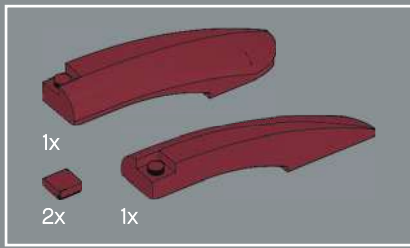

14

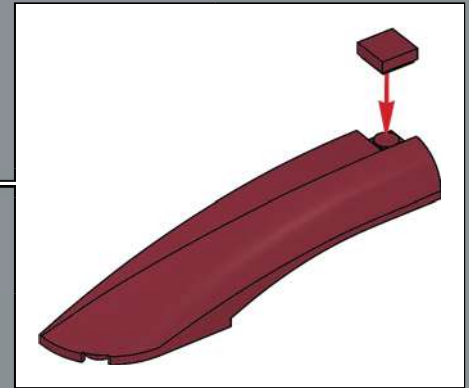
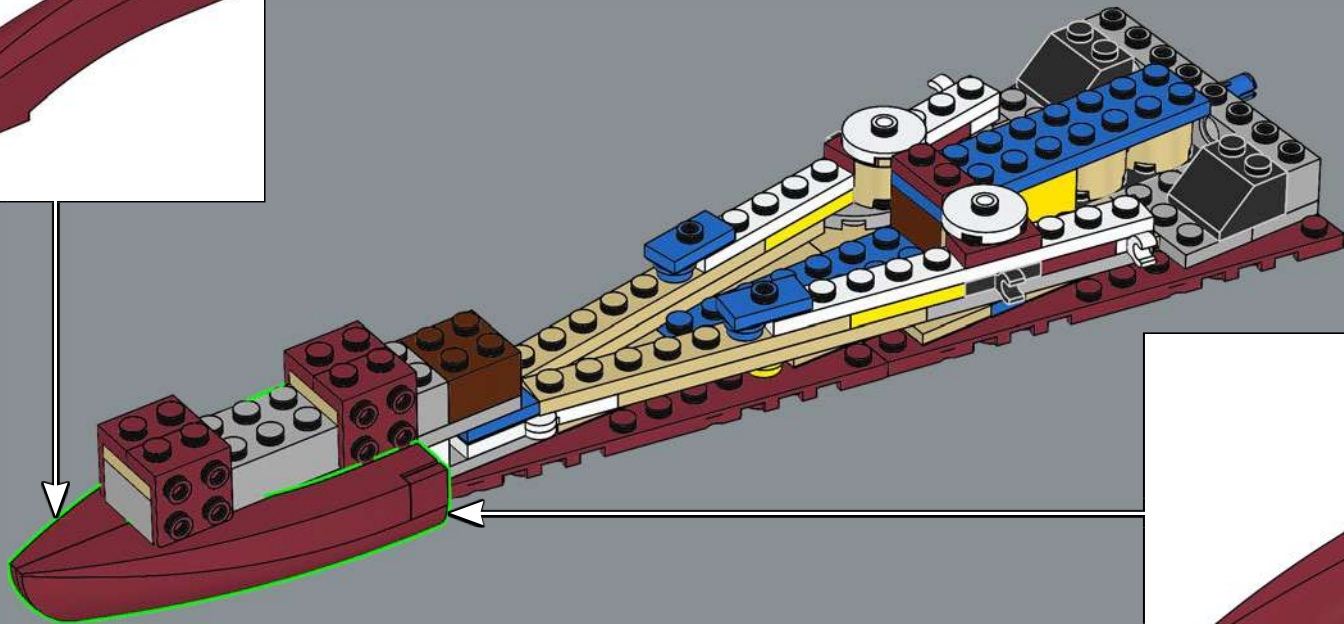
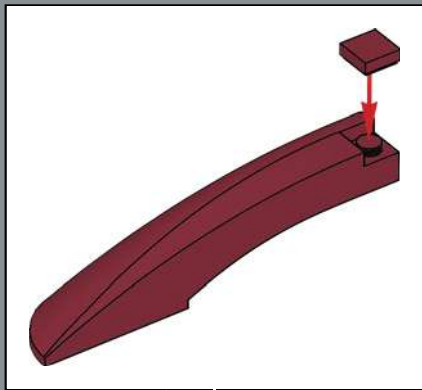

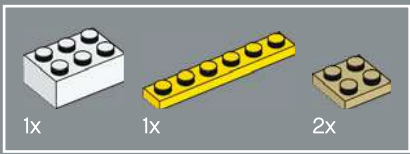

15

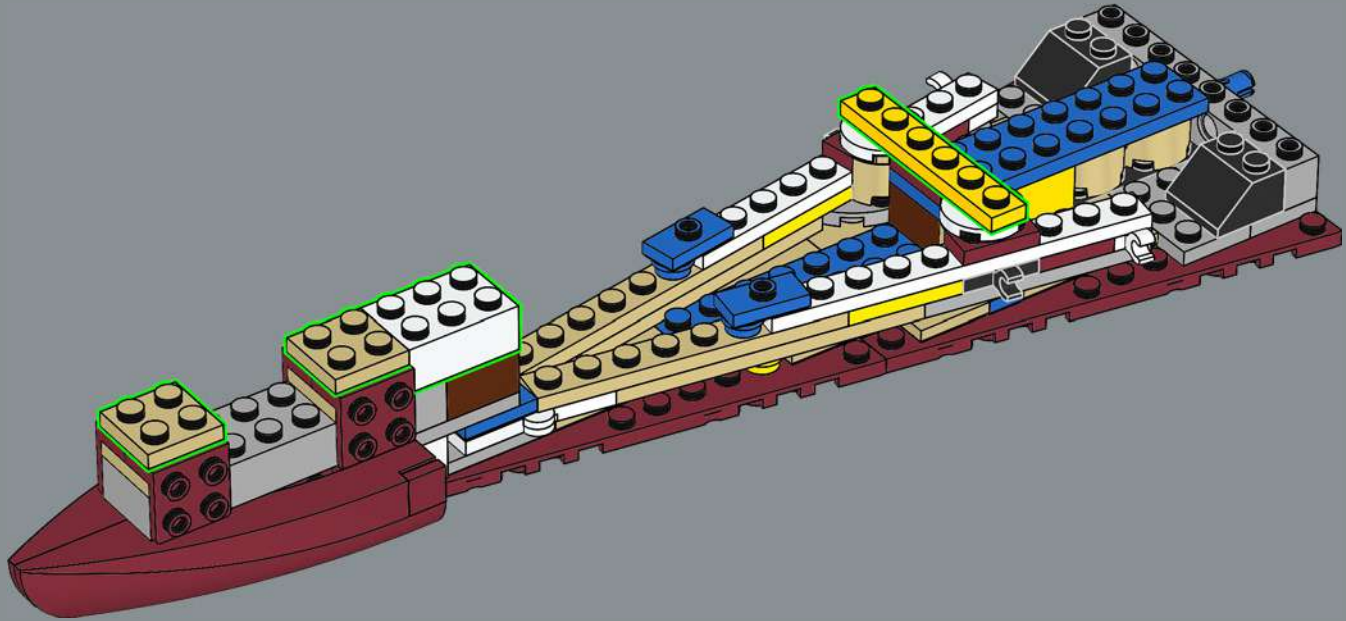

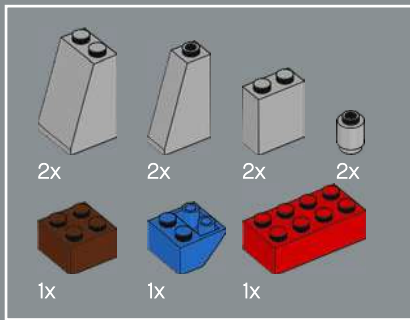

16

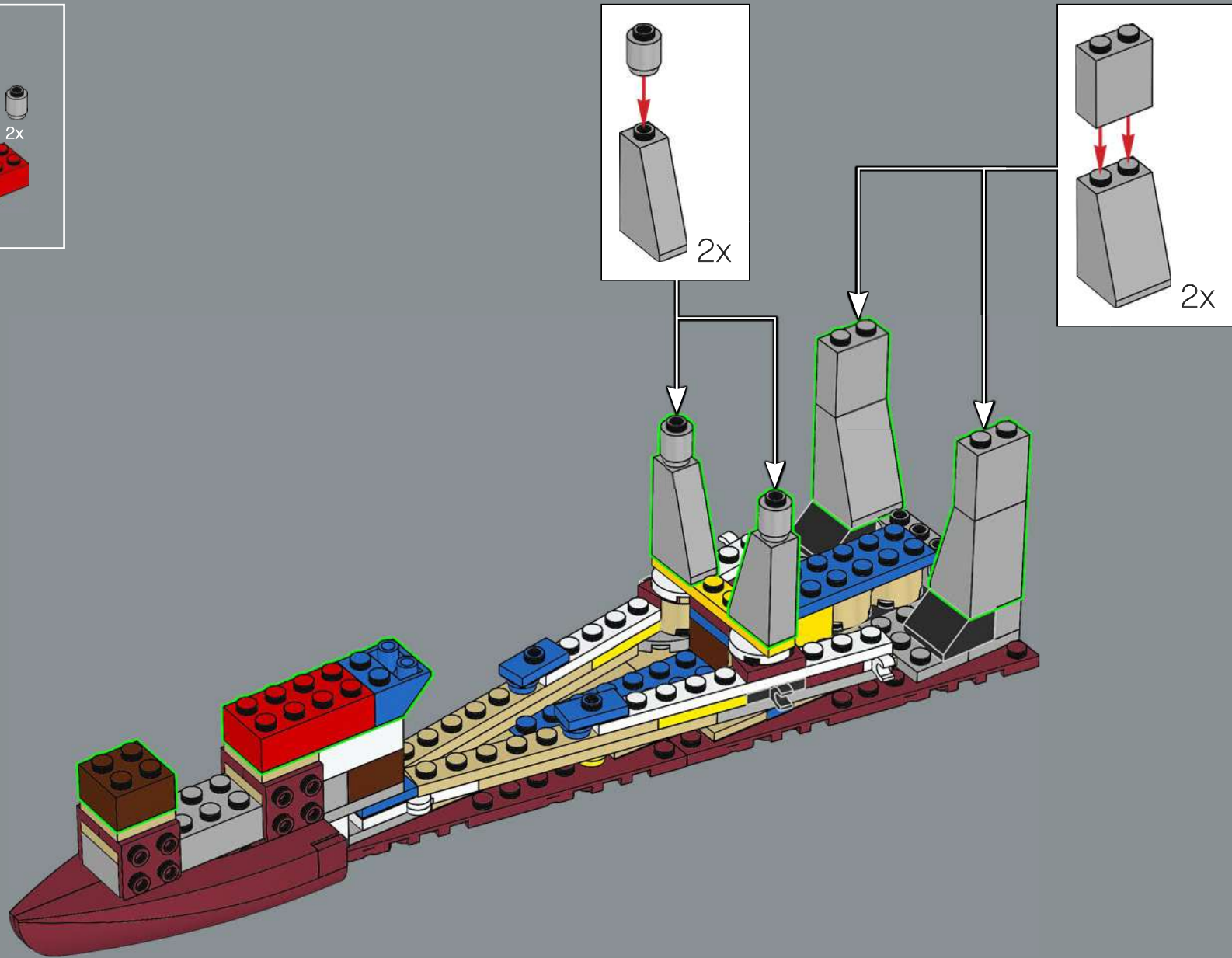

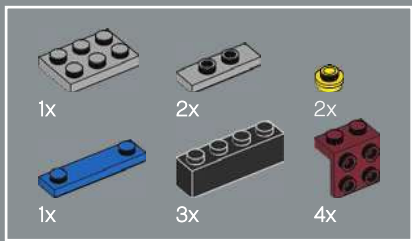

17

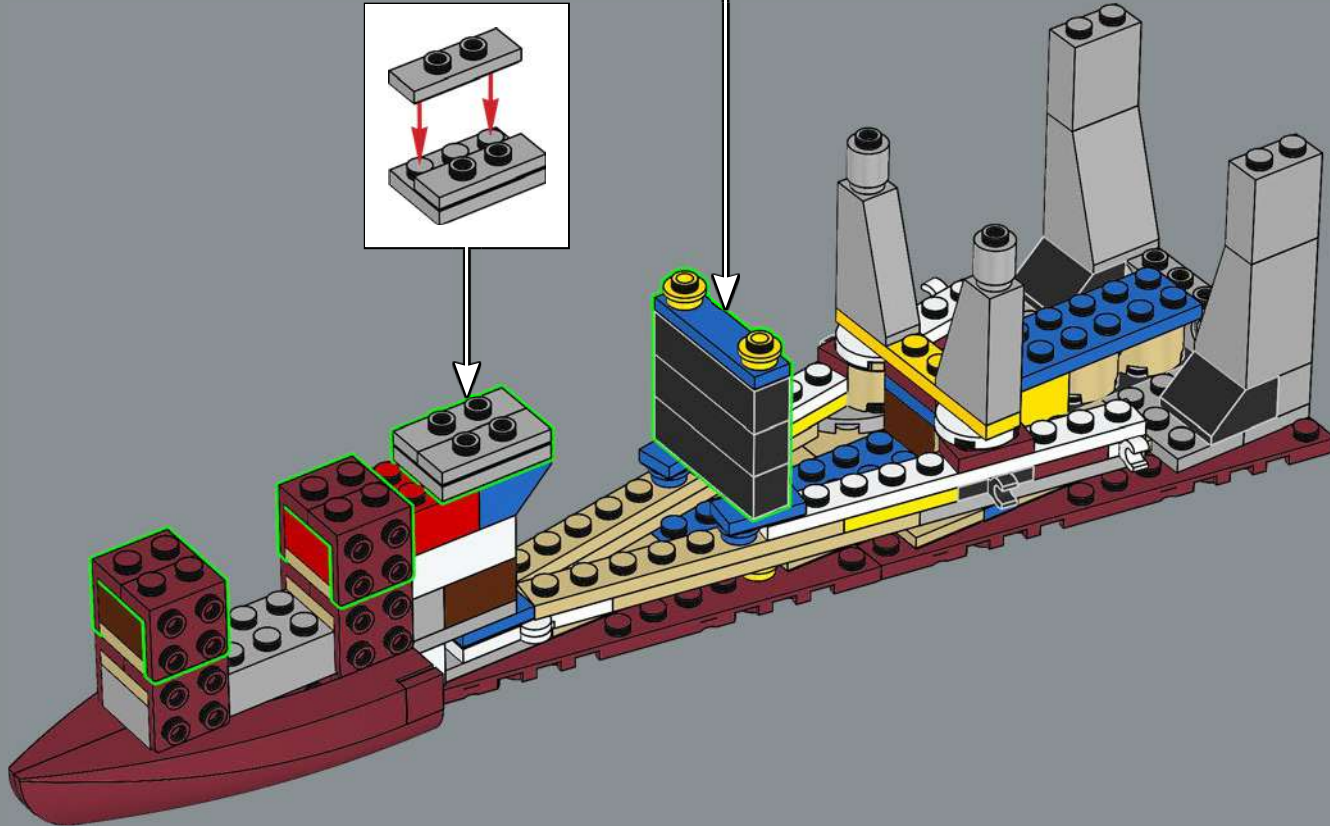
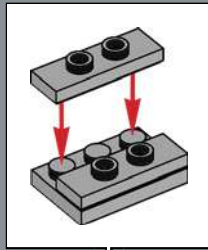
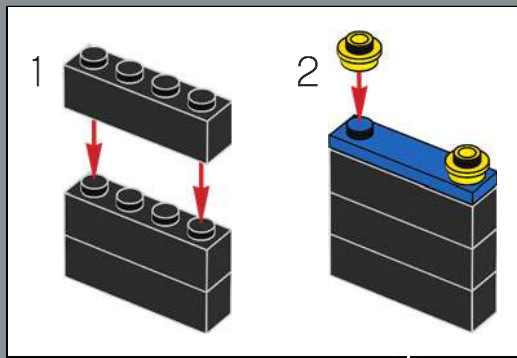

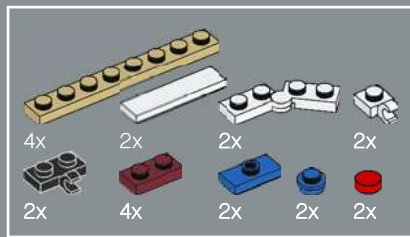

18

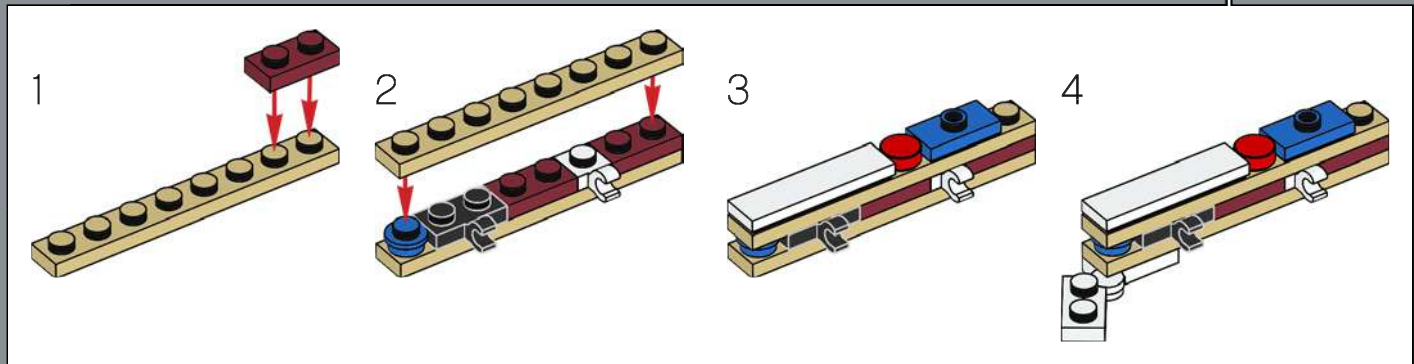
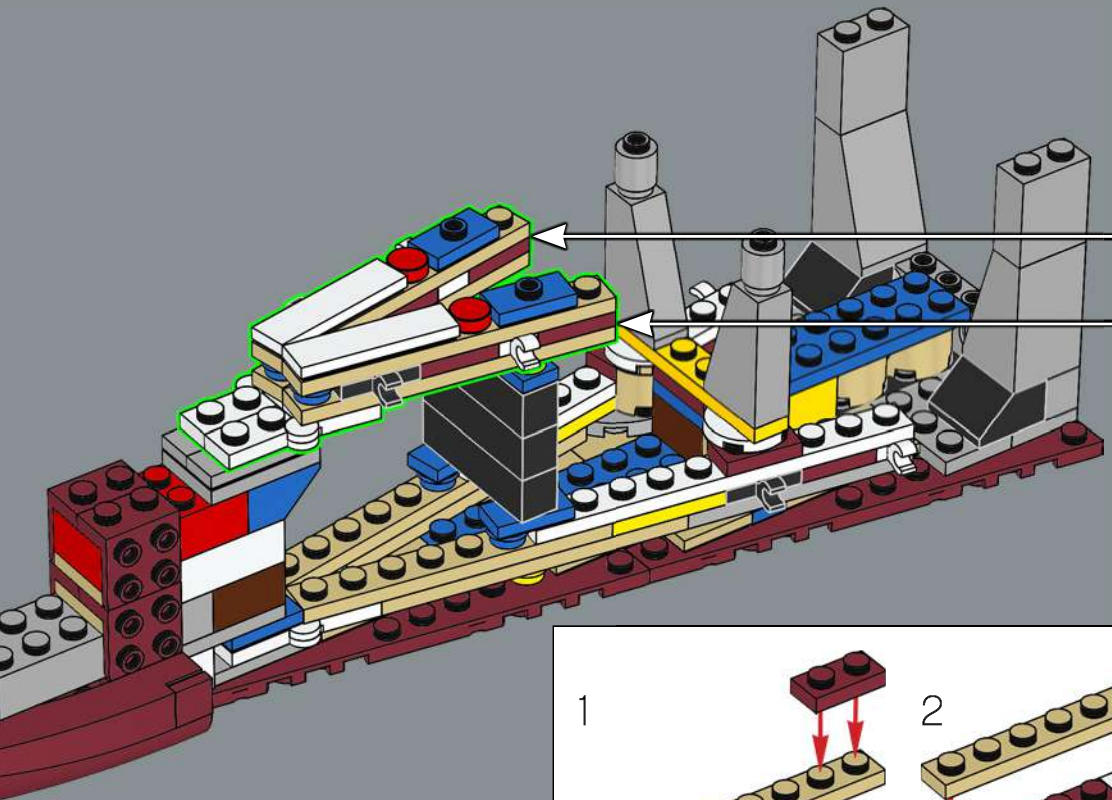
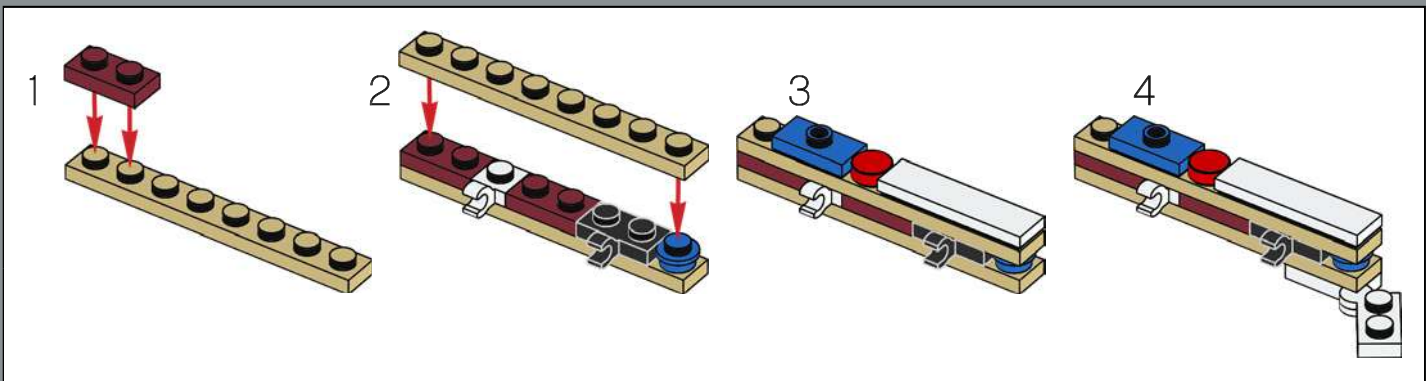

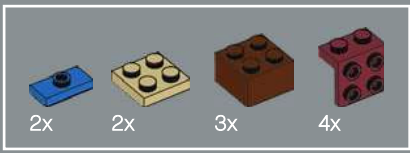

19

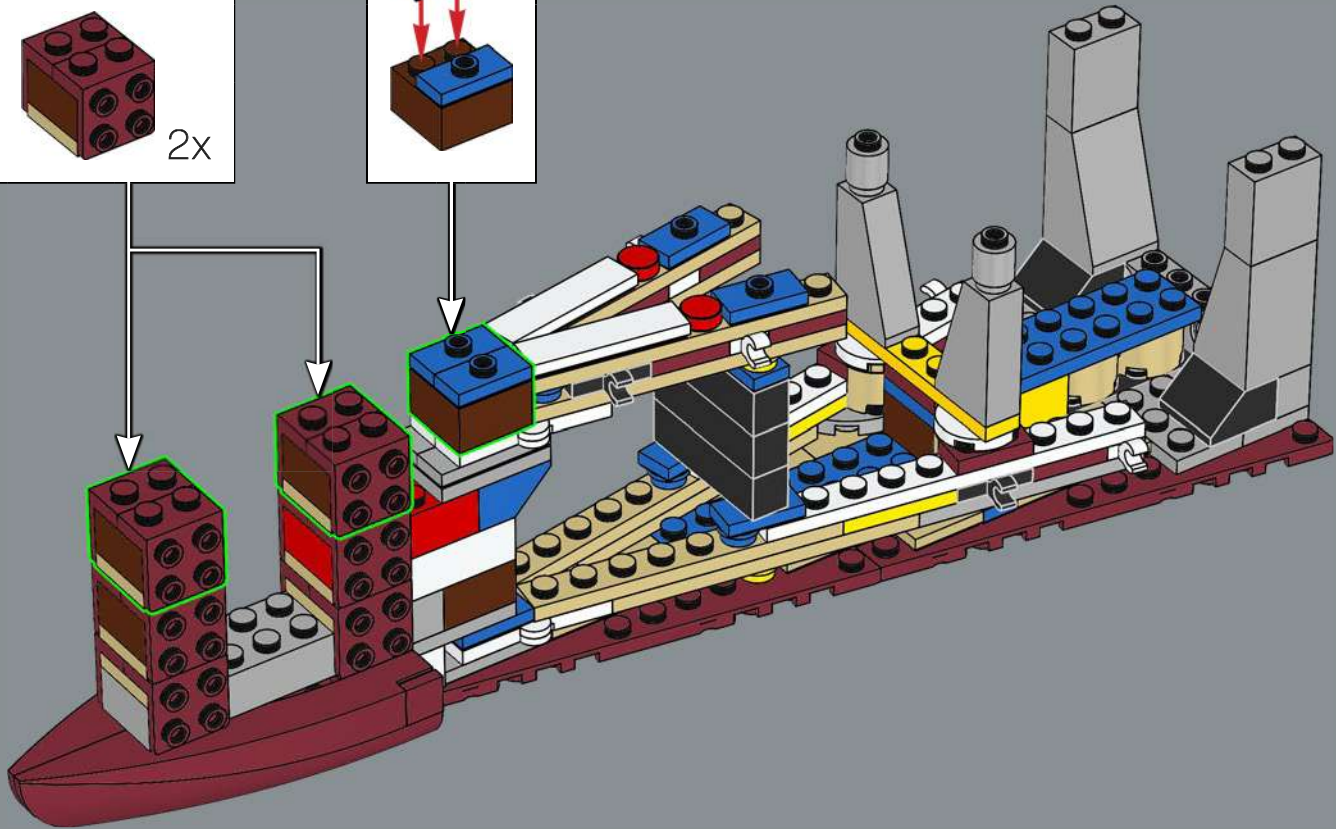
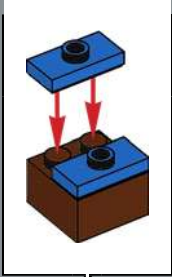
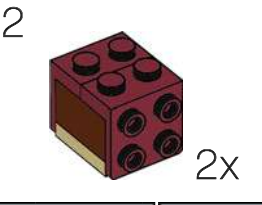
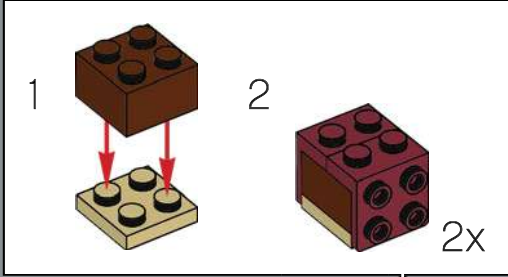

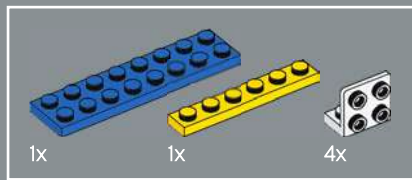

20

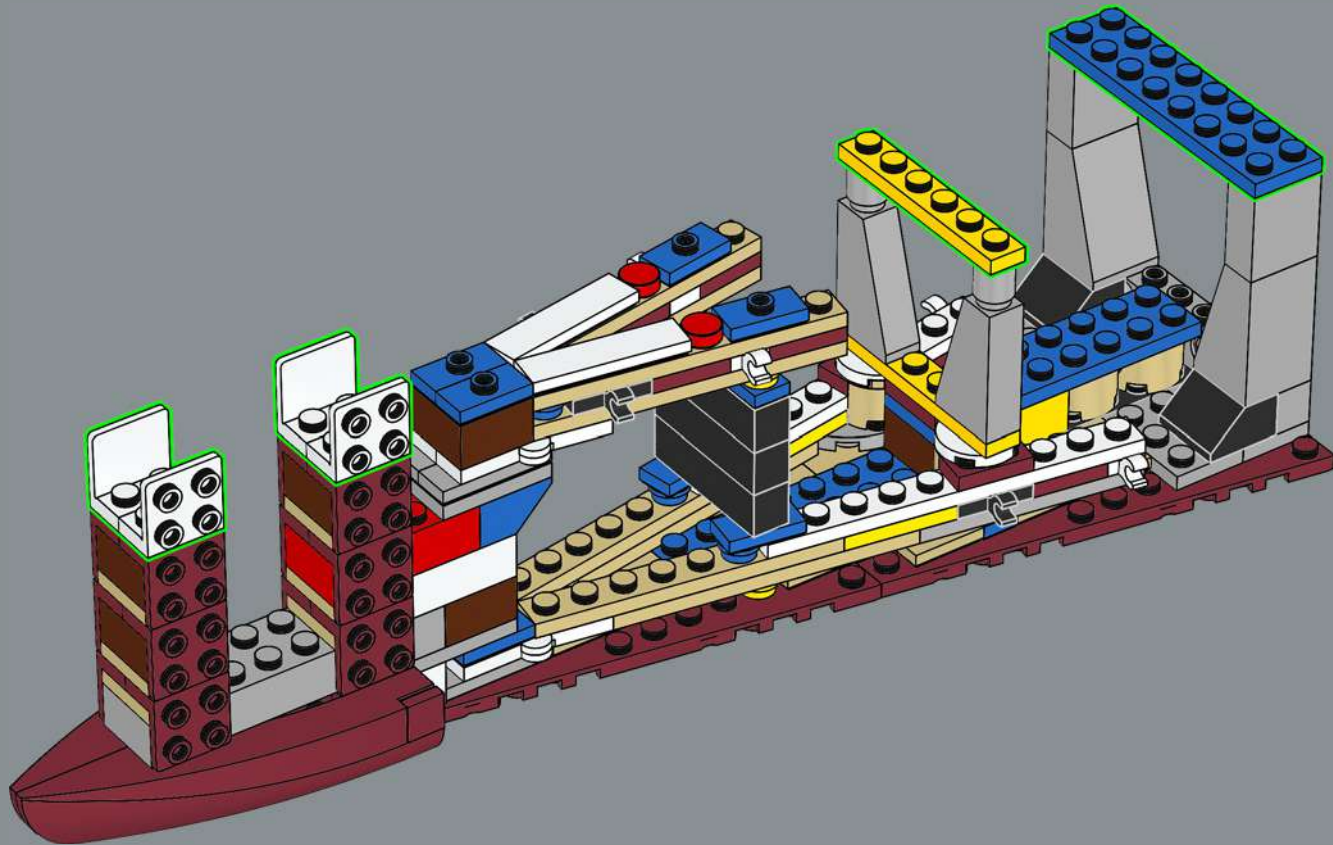

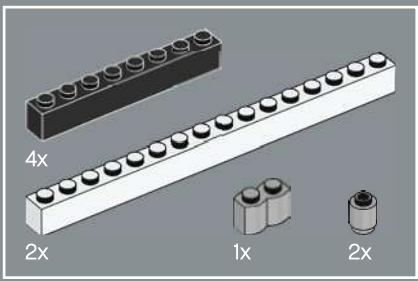

21

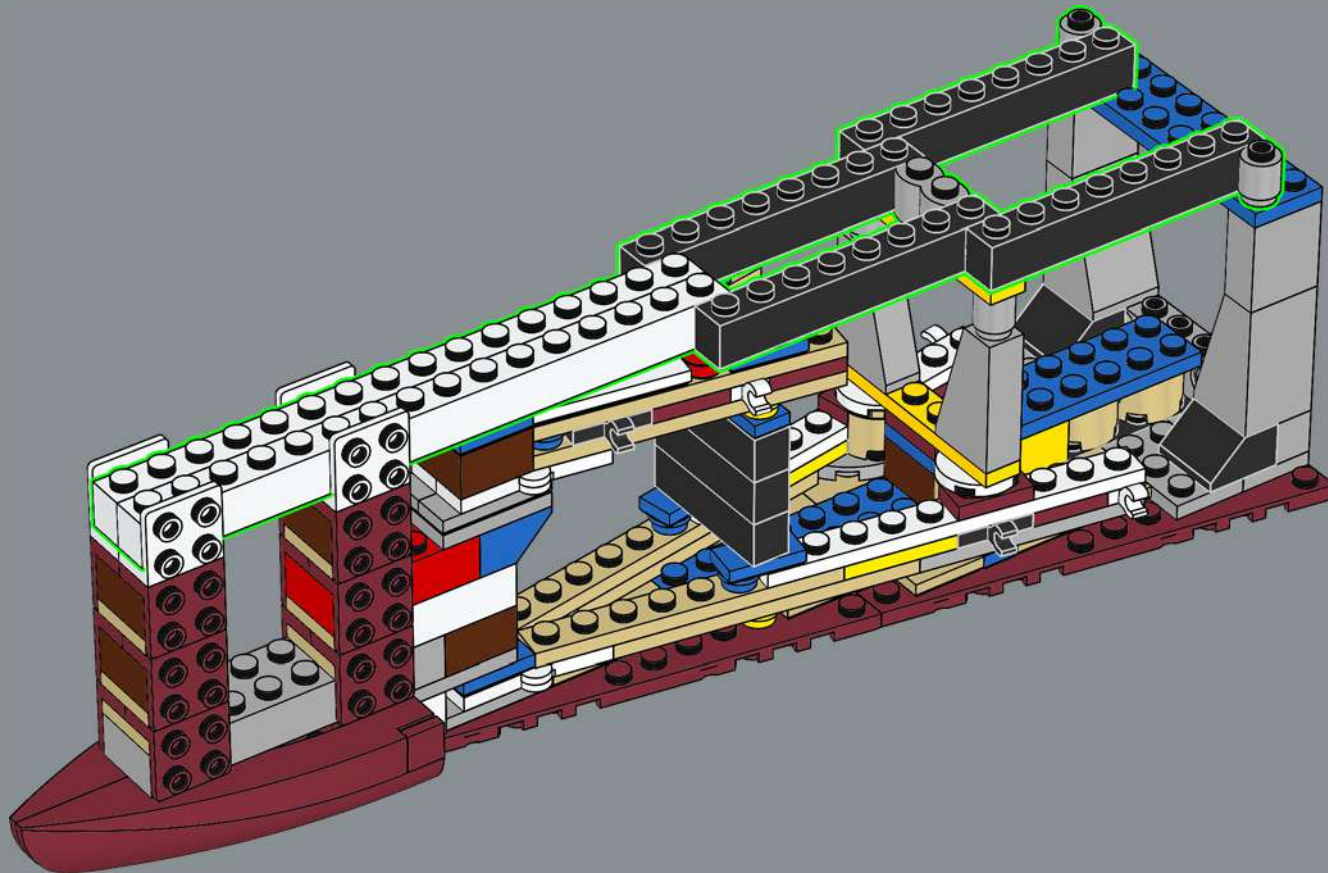

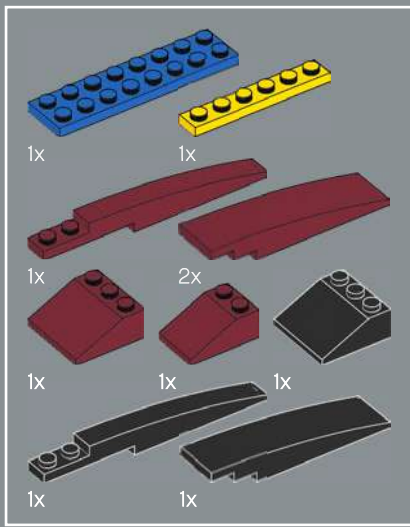

22

1

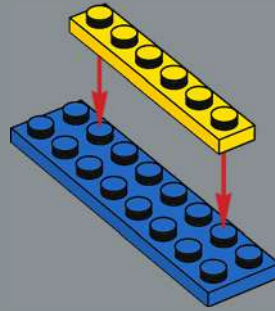

2

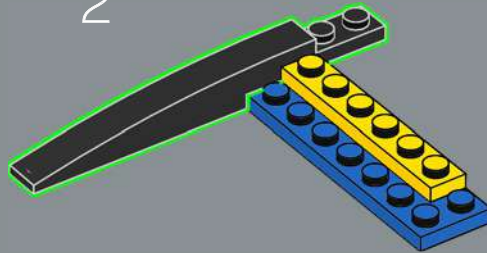

3

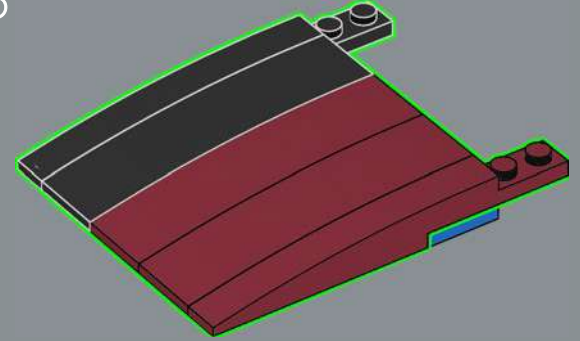

4

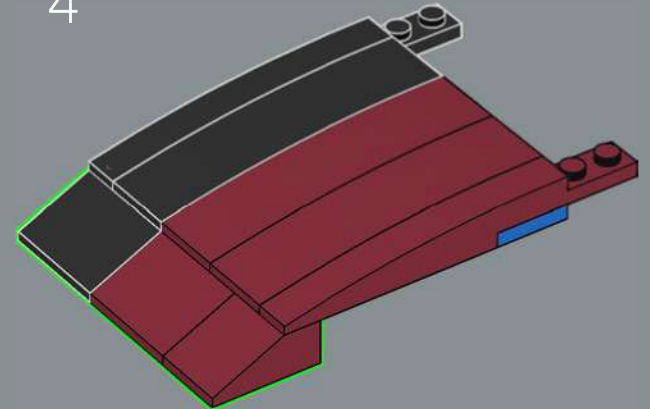

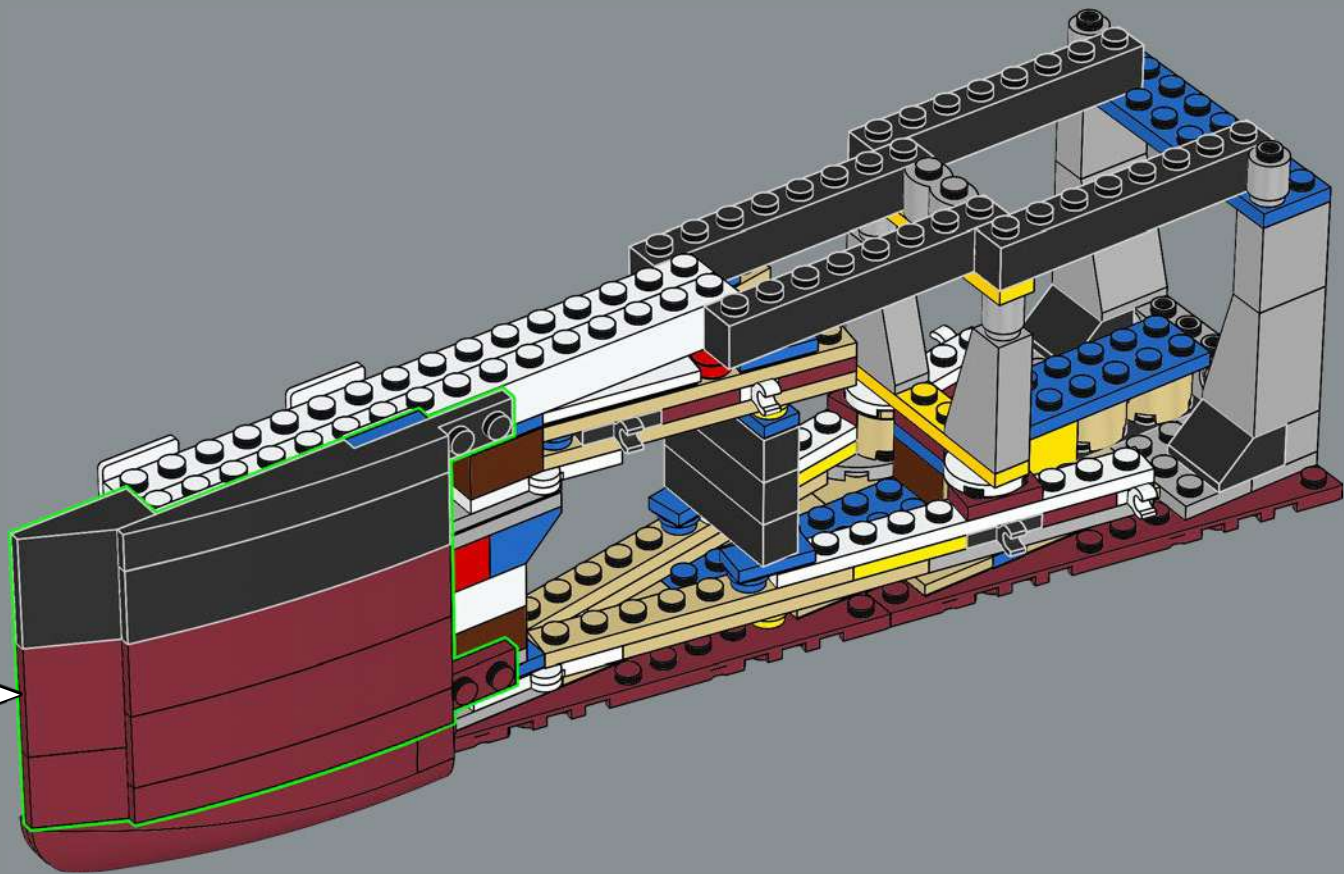

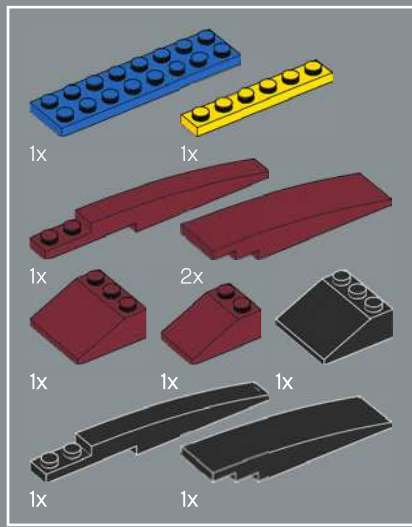

23

1

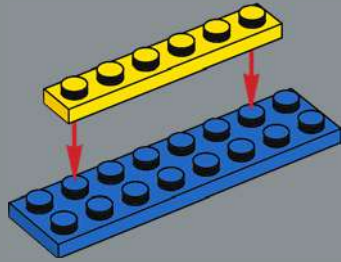

2

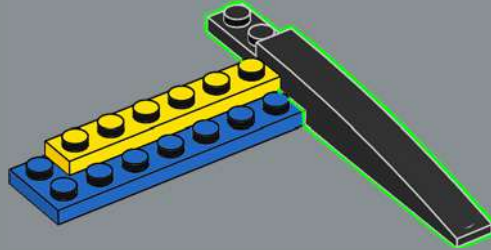

3

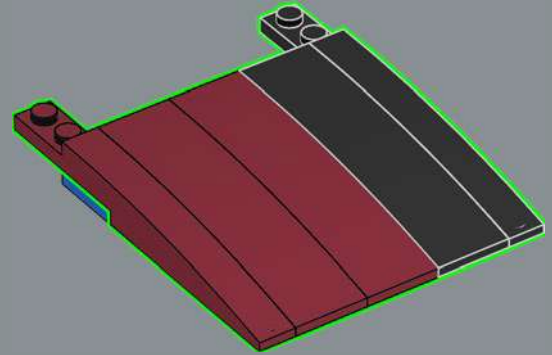

4

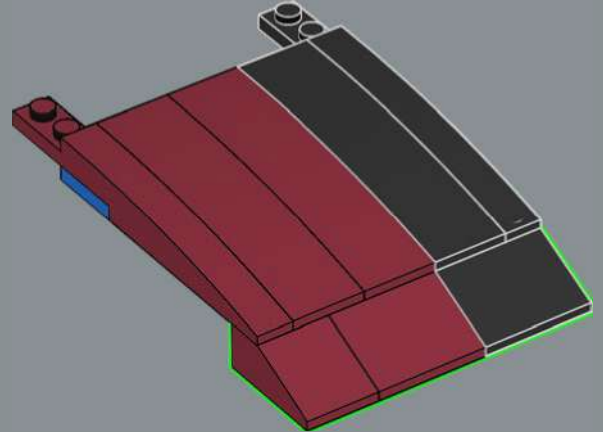

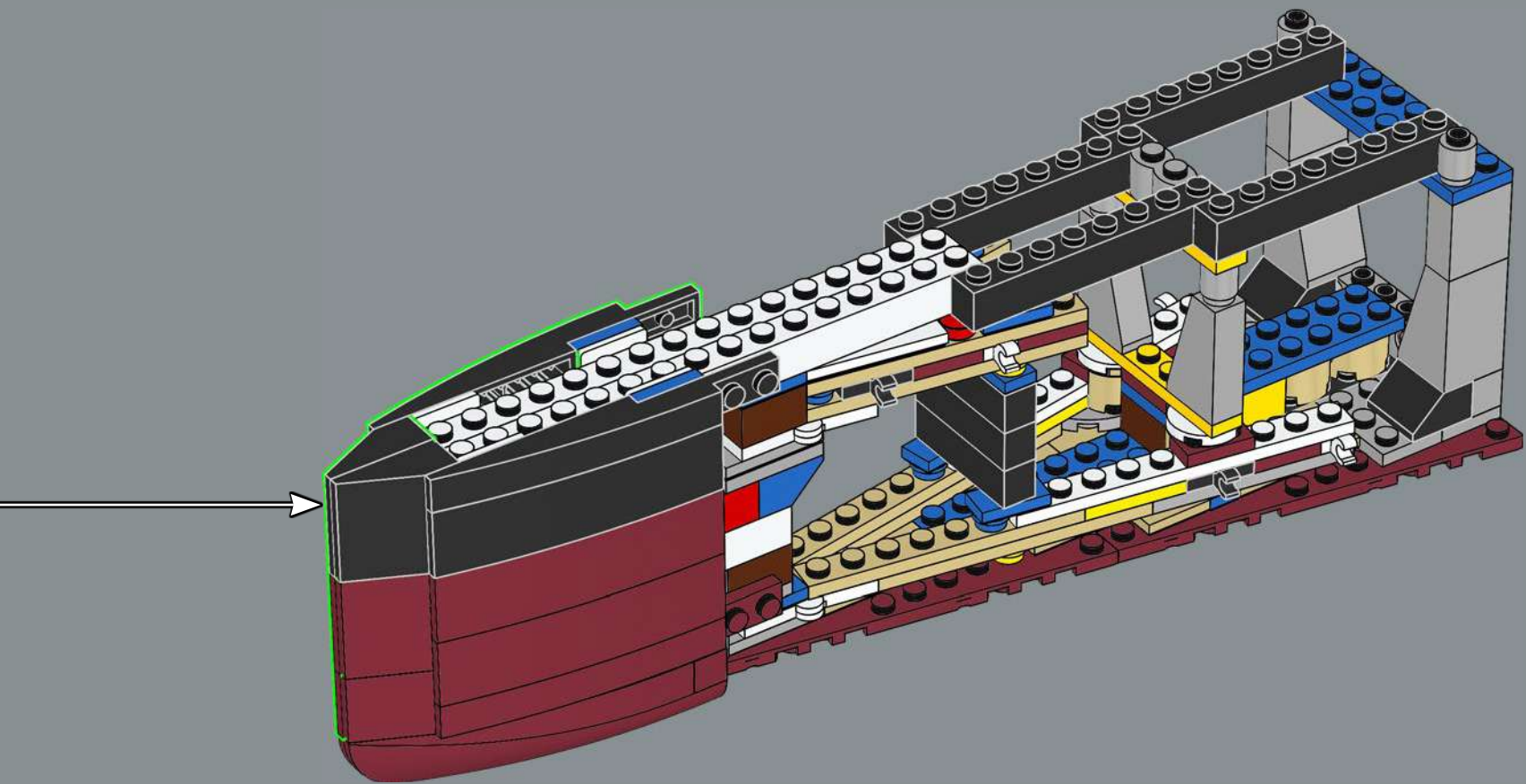

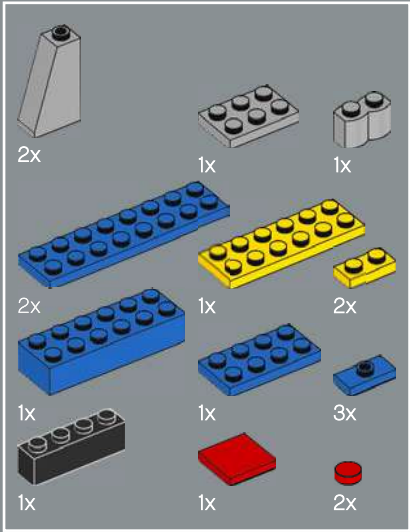
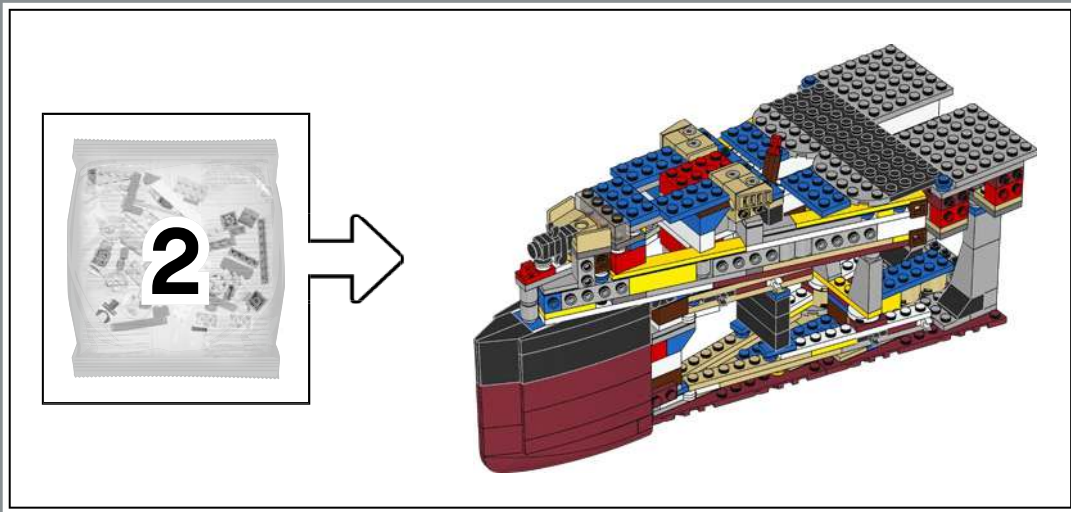

24

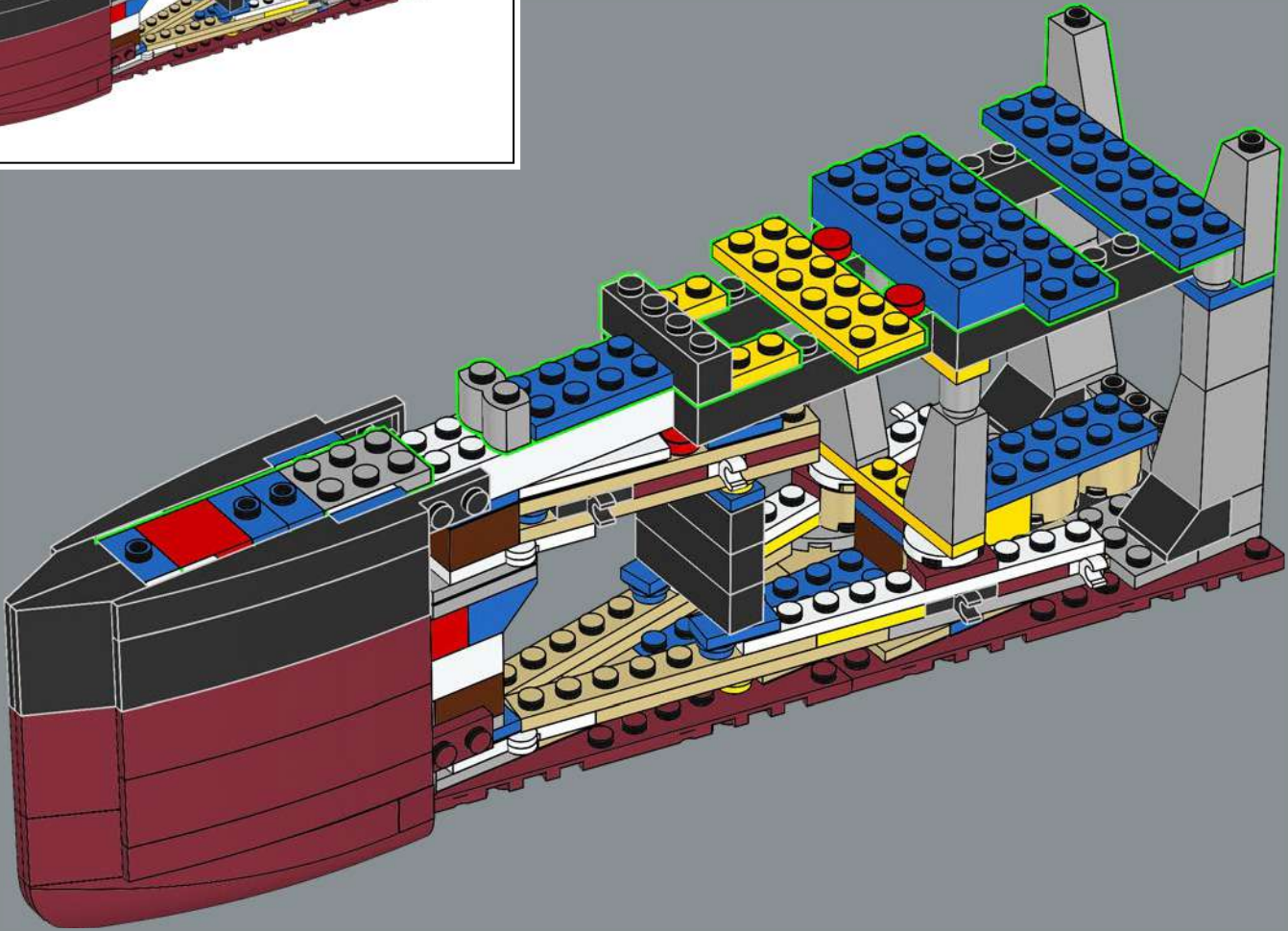

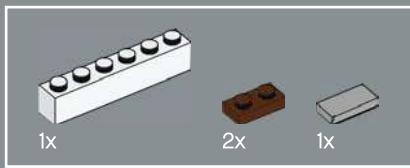

25

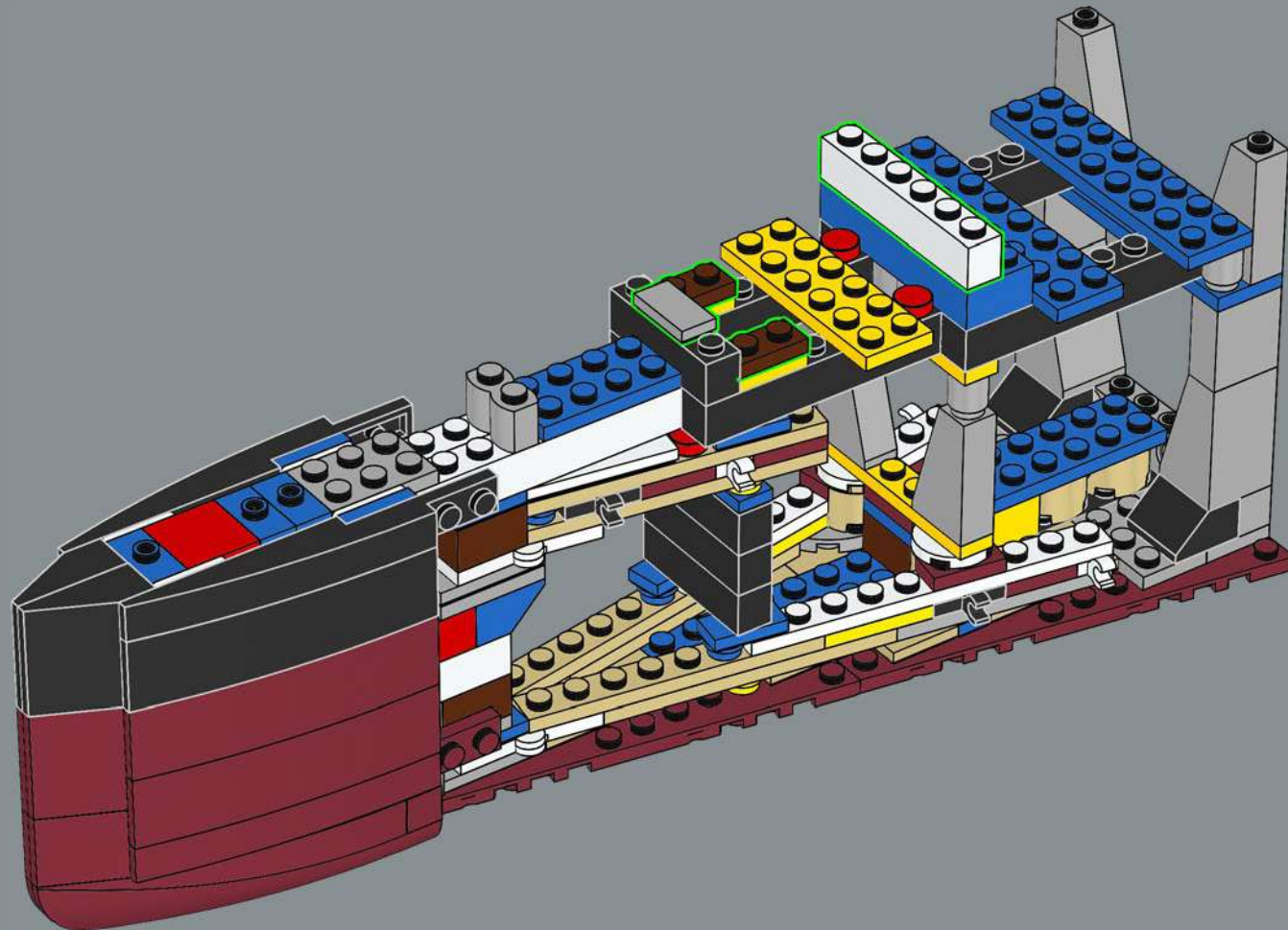

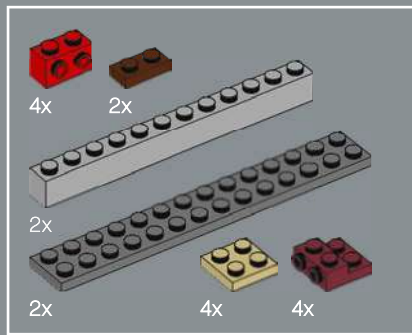

26

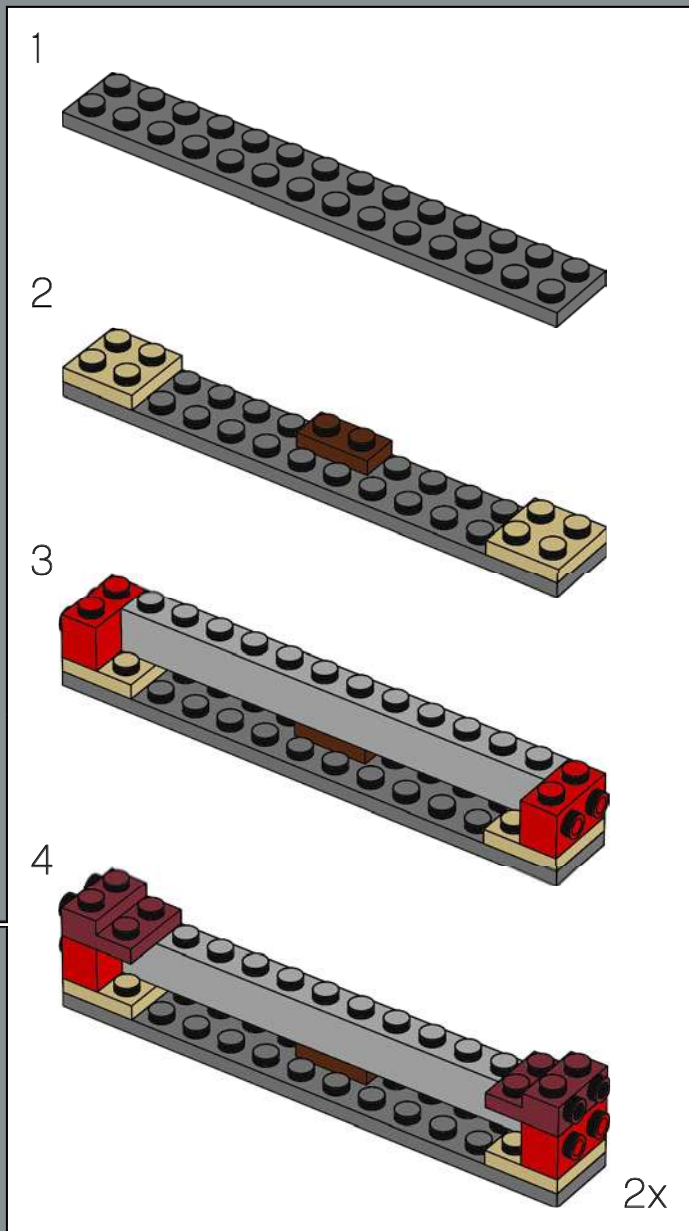
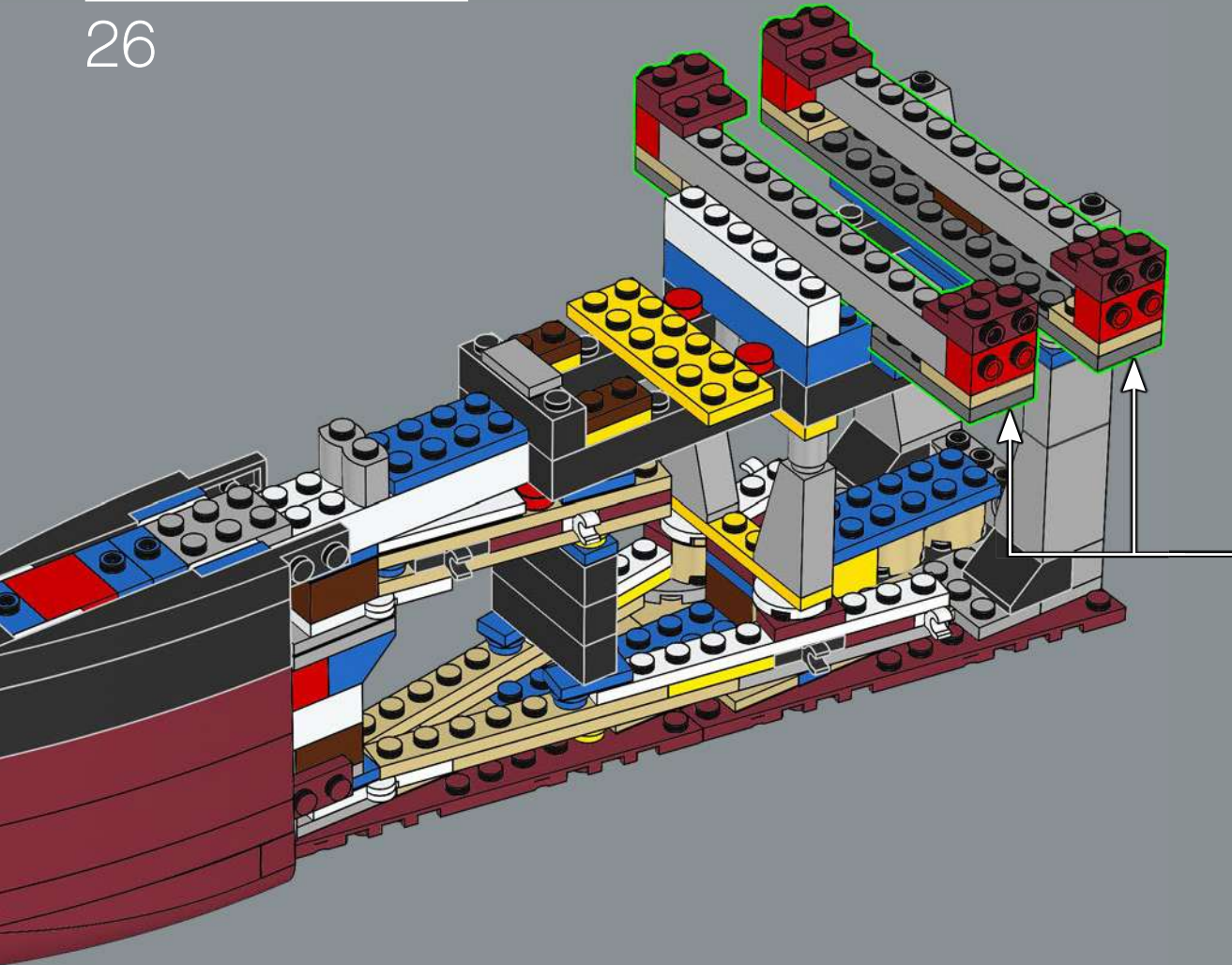

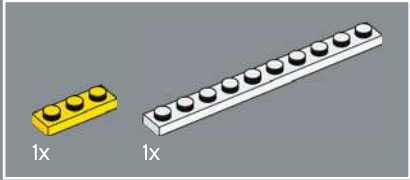
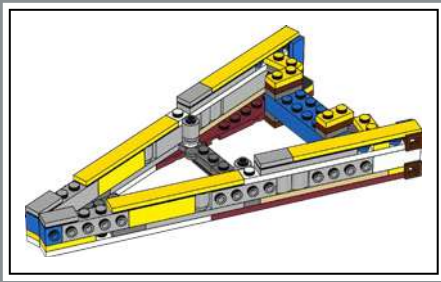

27

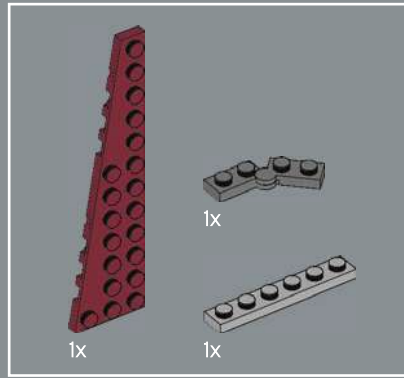
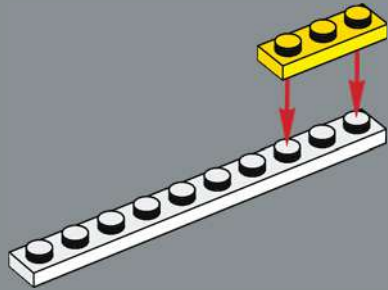

28

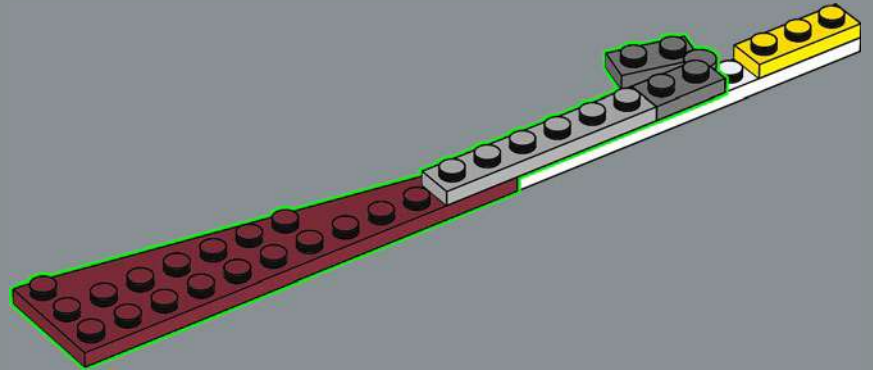

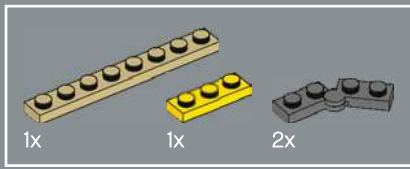

29

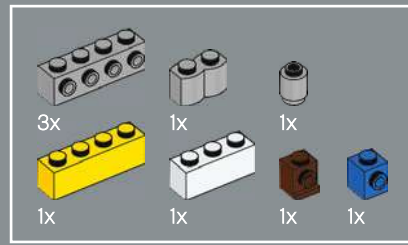
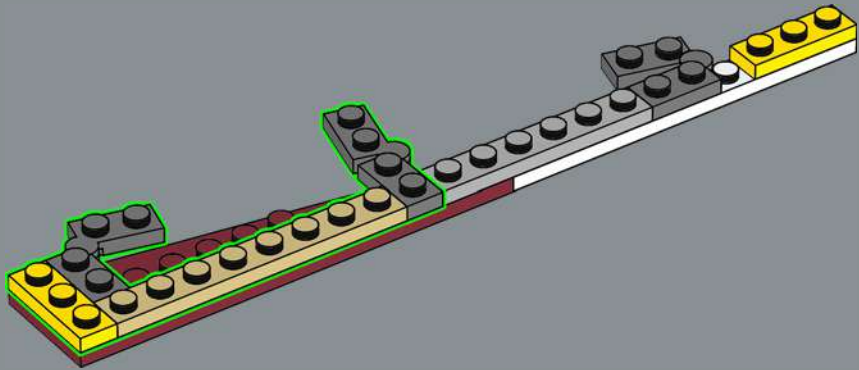

30

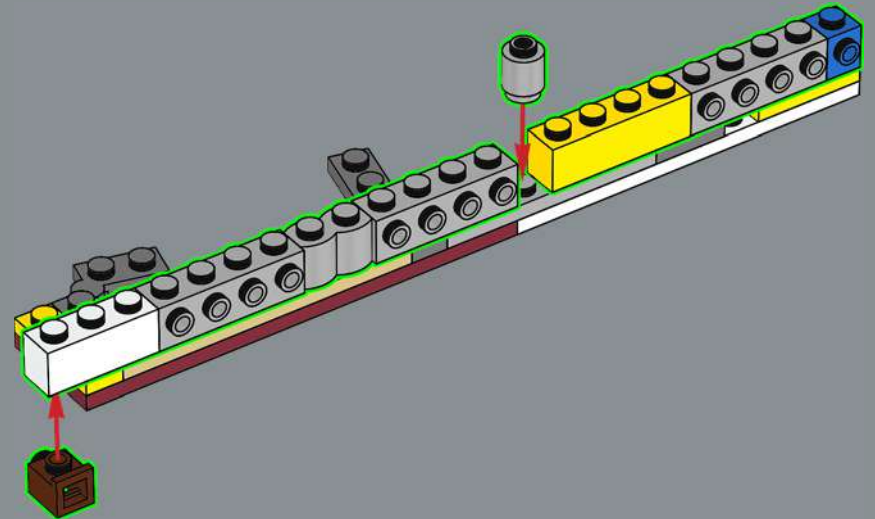



31

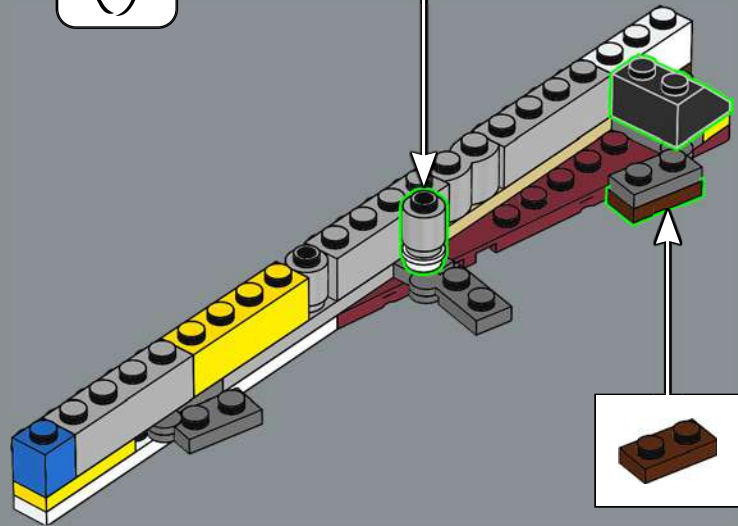
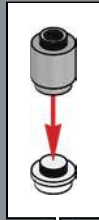

32

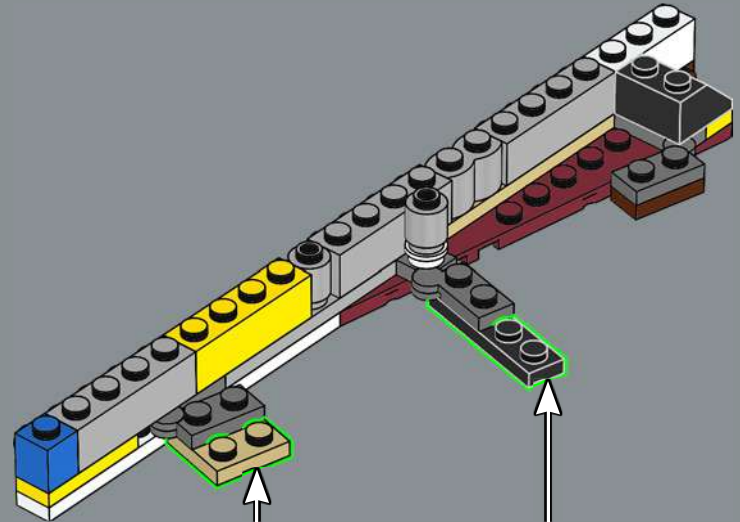

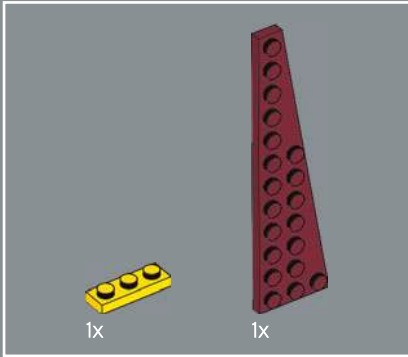
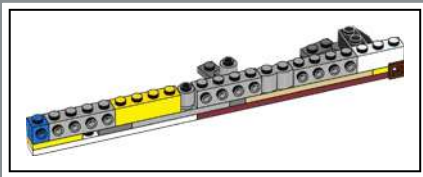

33

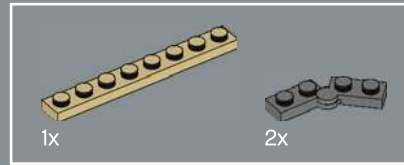
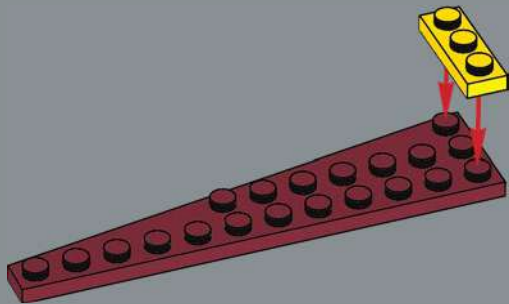

34

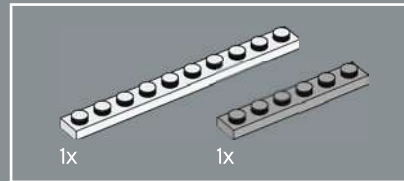
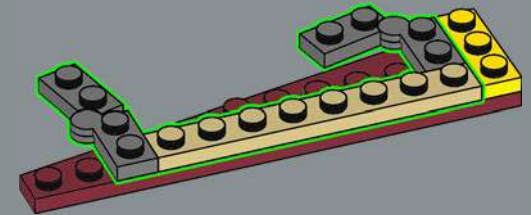

35

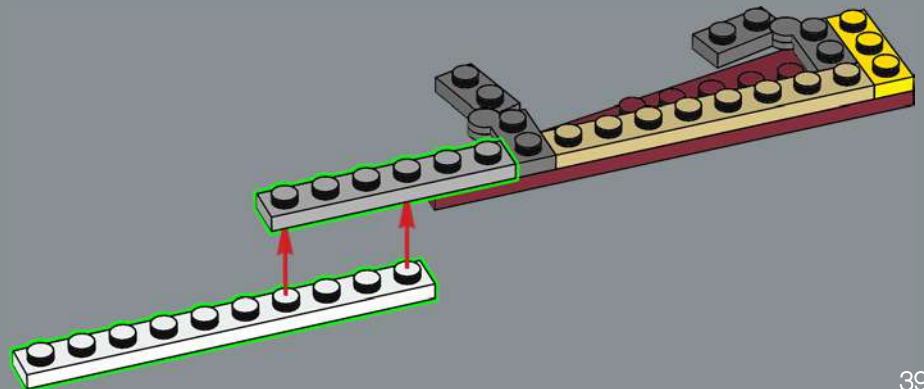

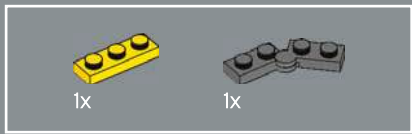

36

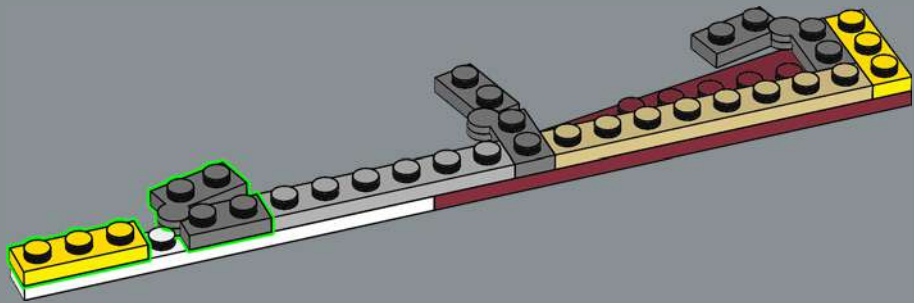

37

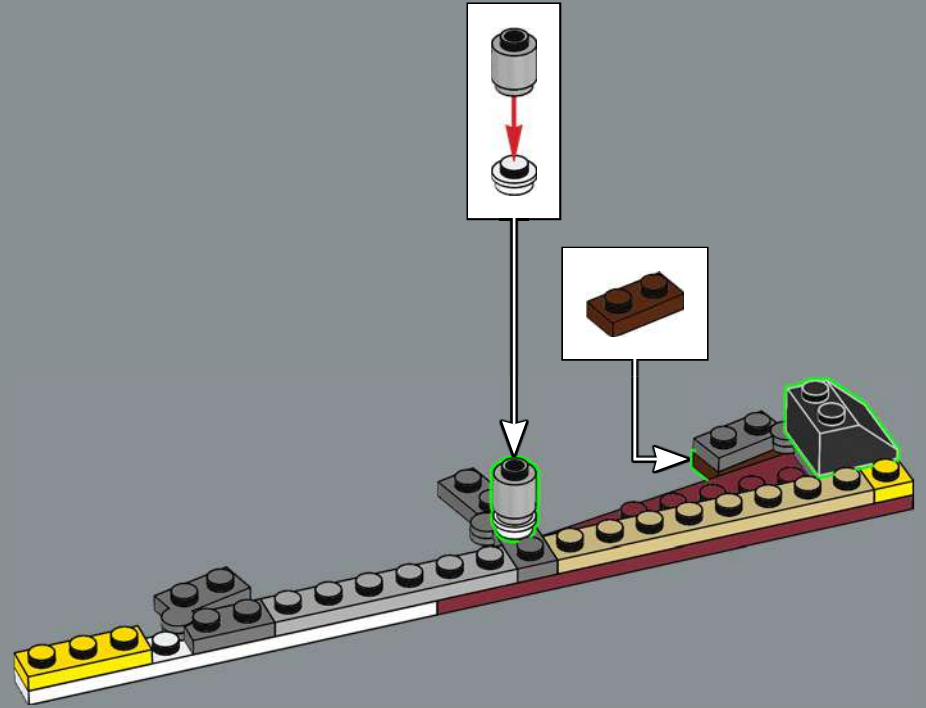

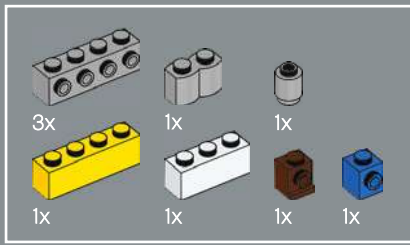

38

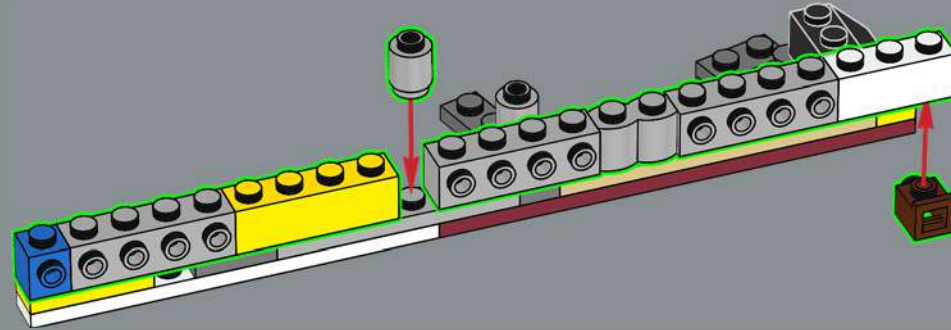

39

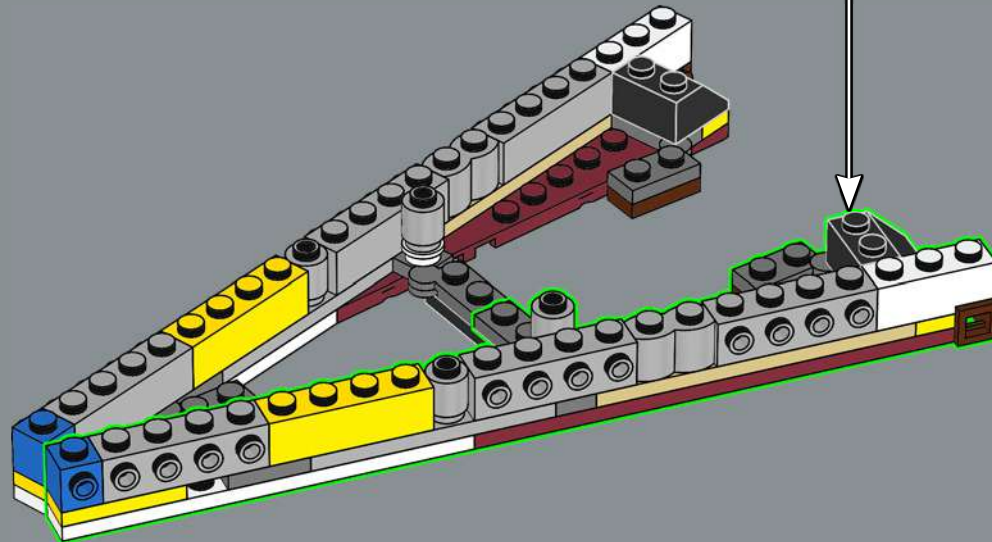

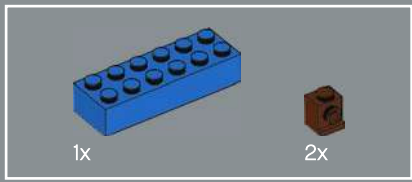

40

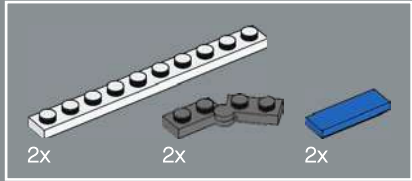
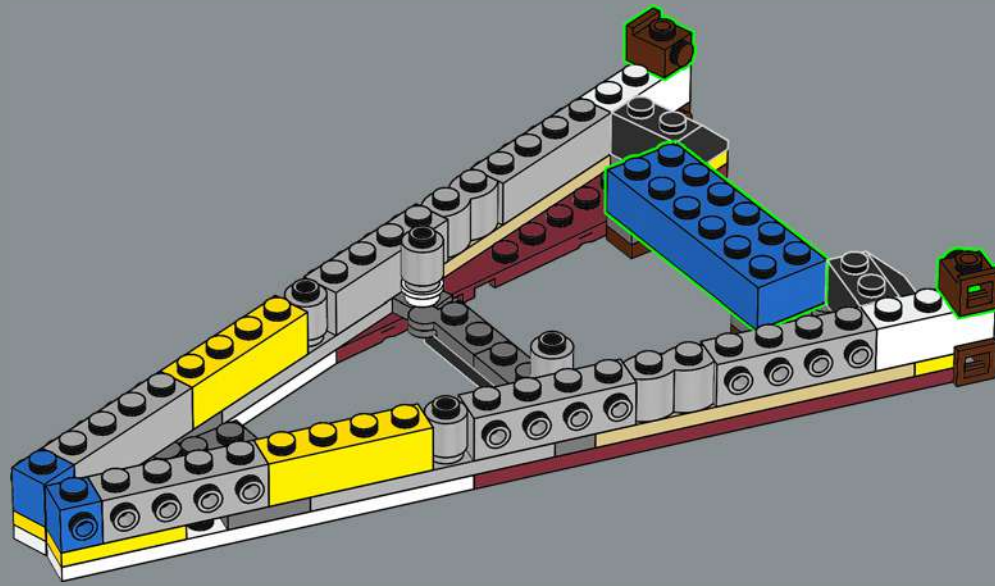

41

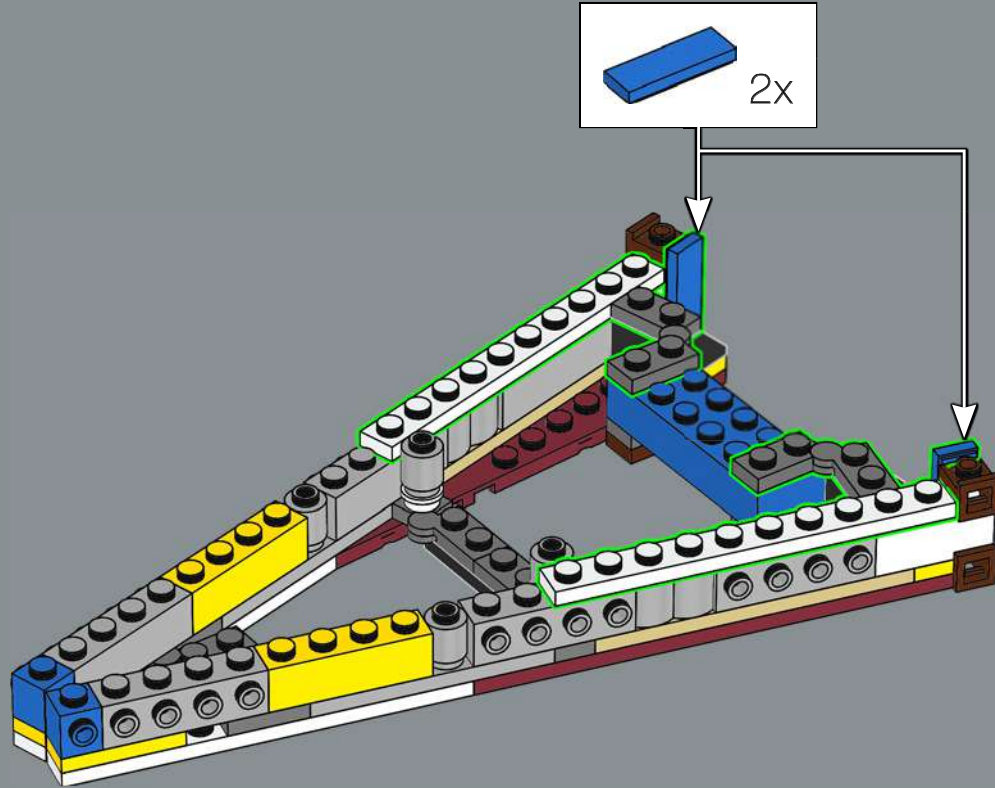
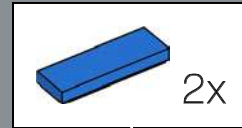

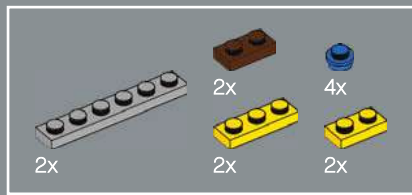

42

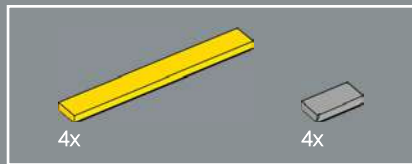
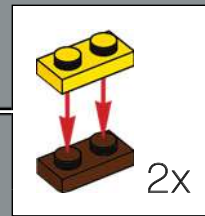
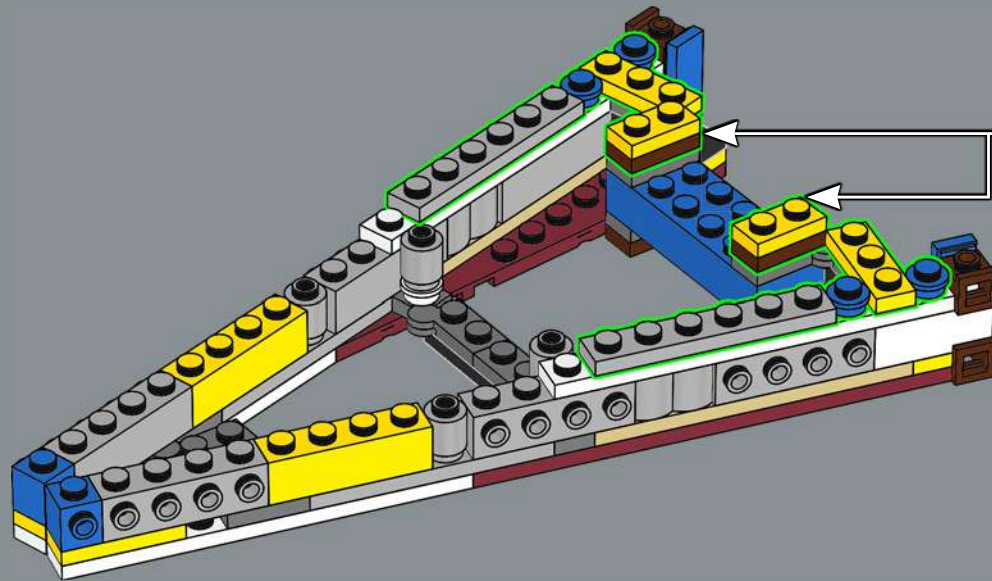

43

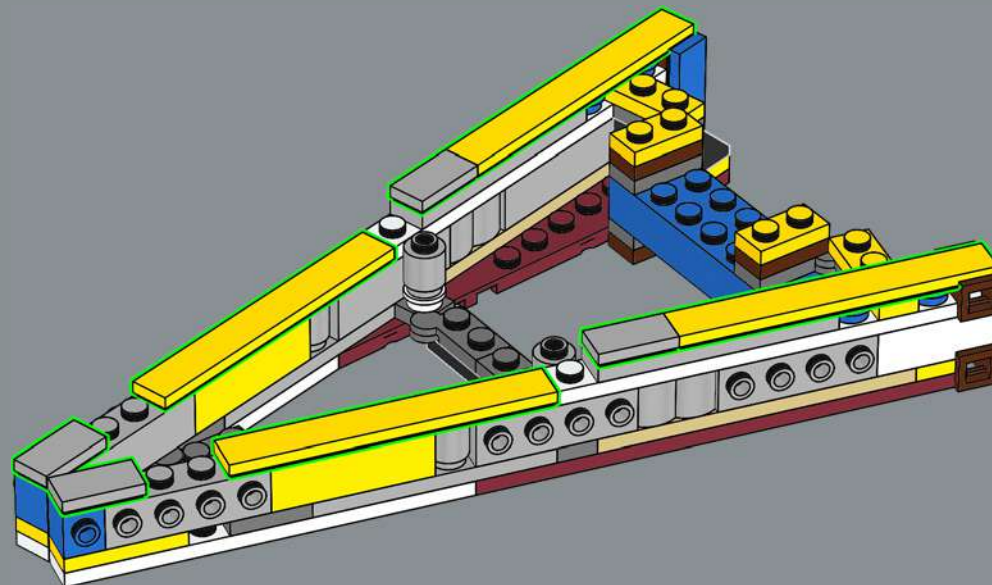

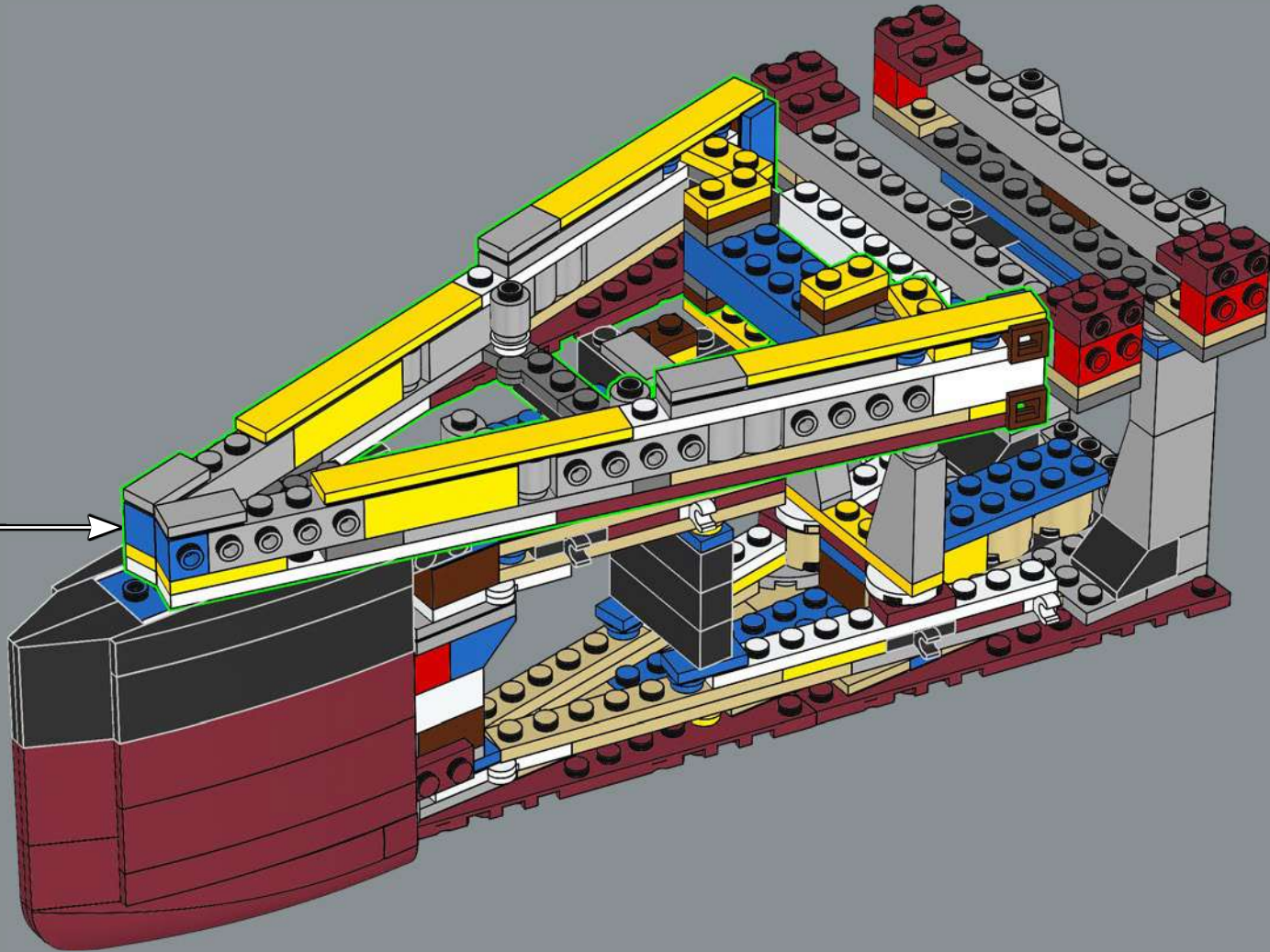

The construction of the *Olympic* and *Titanic* took place virtually in parallel. Both ships took 26 months to build.

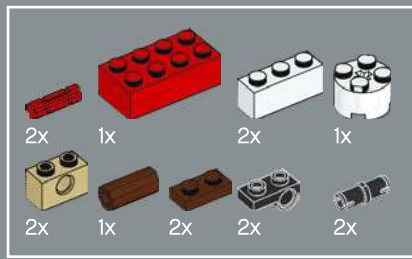

45

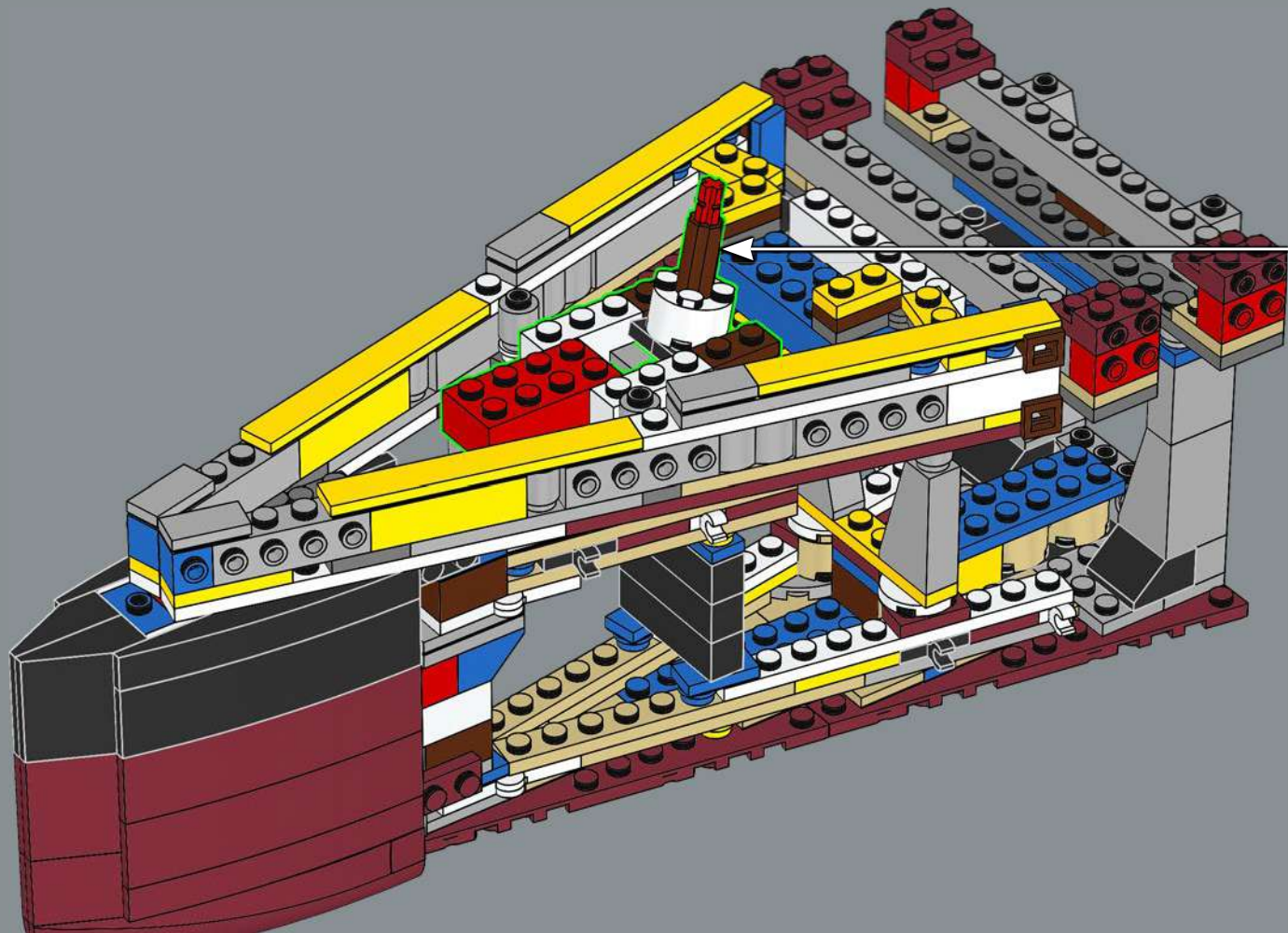
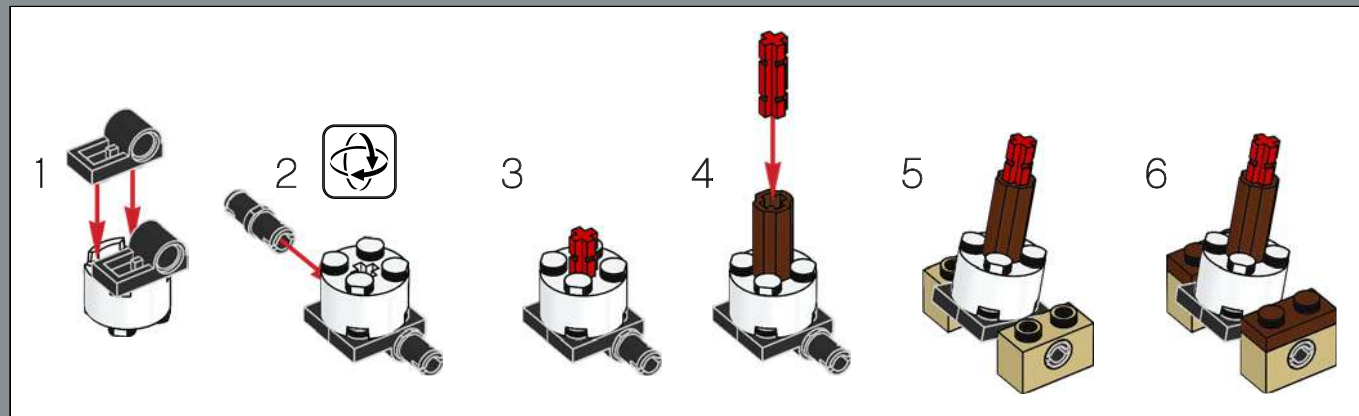

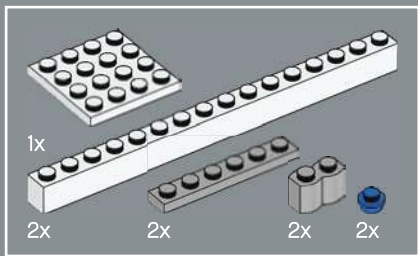

46

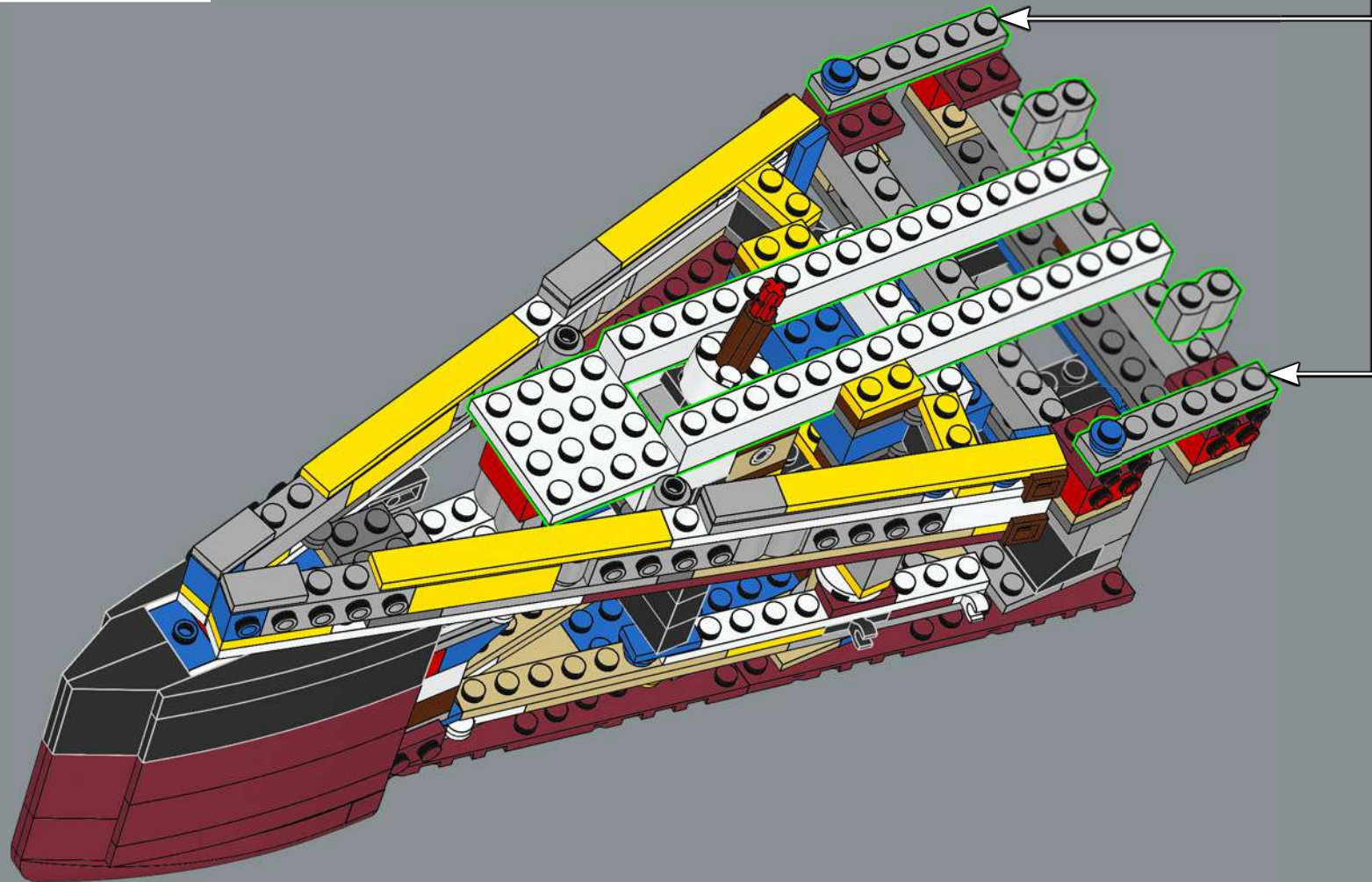
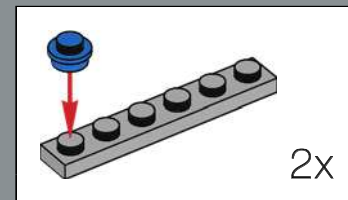

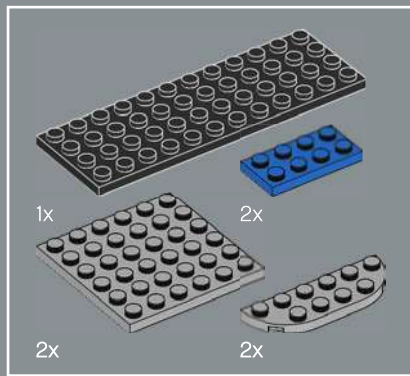

47

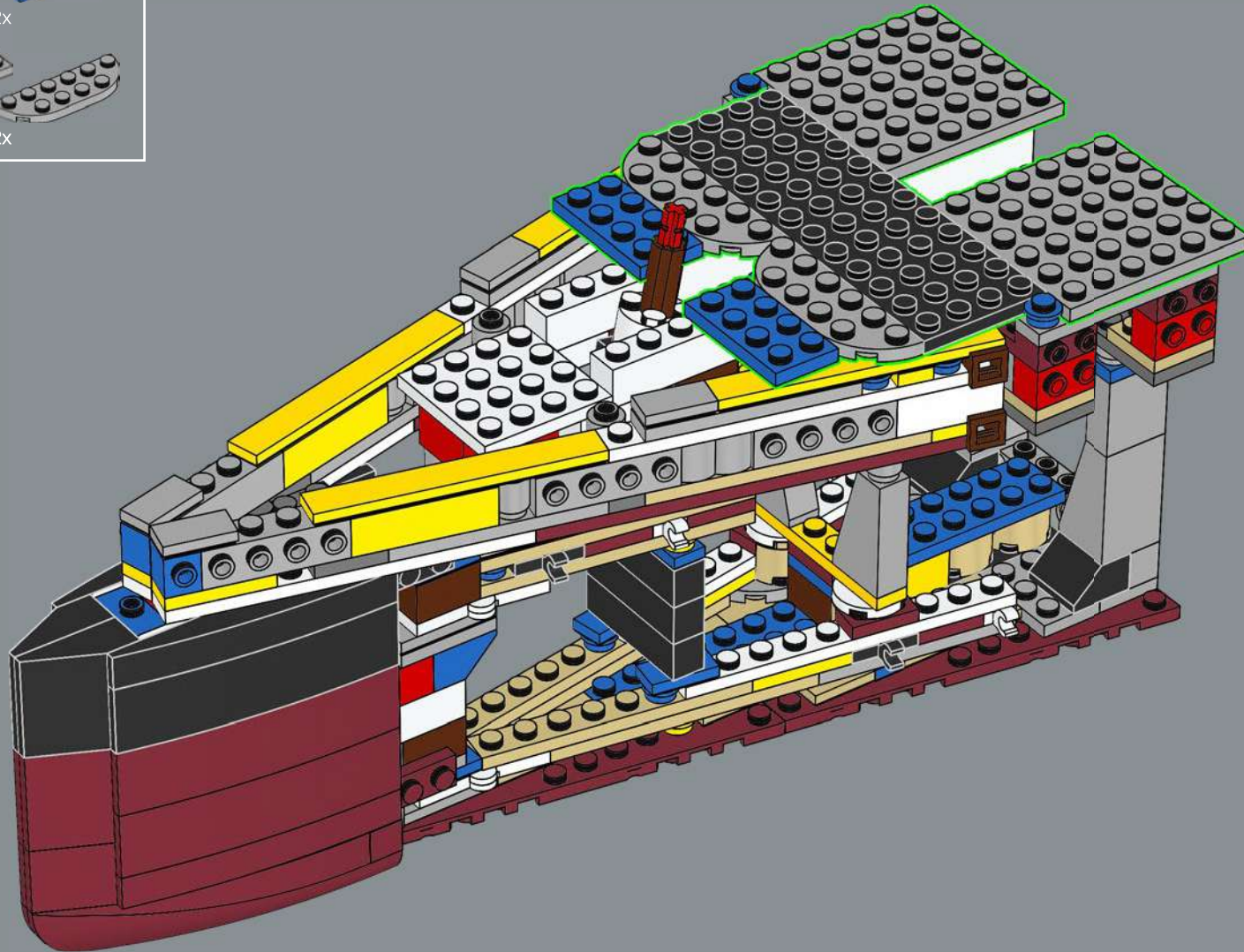

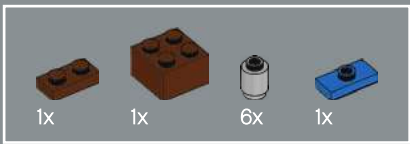

48

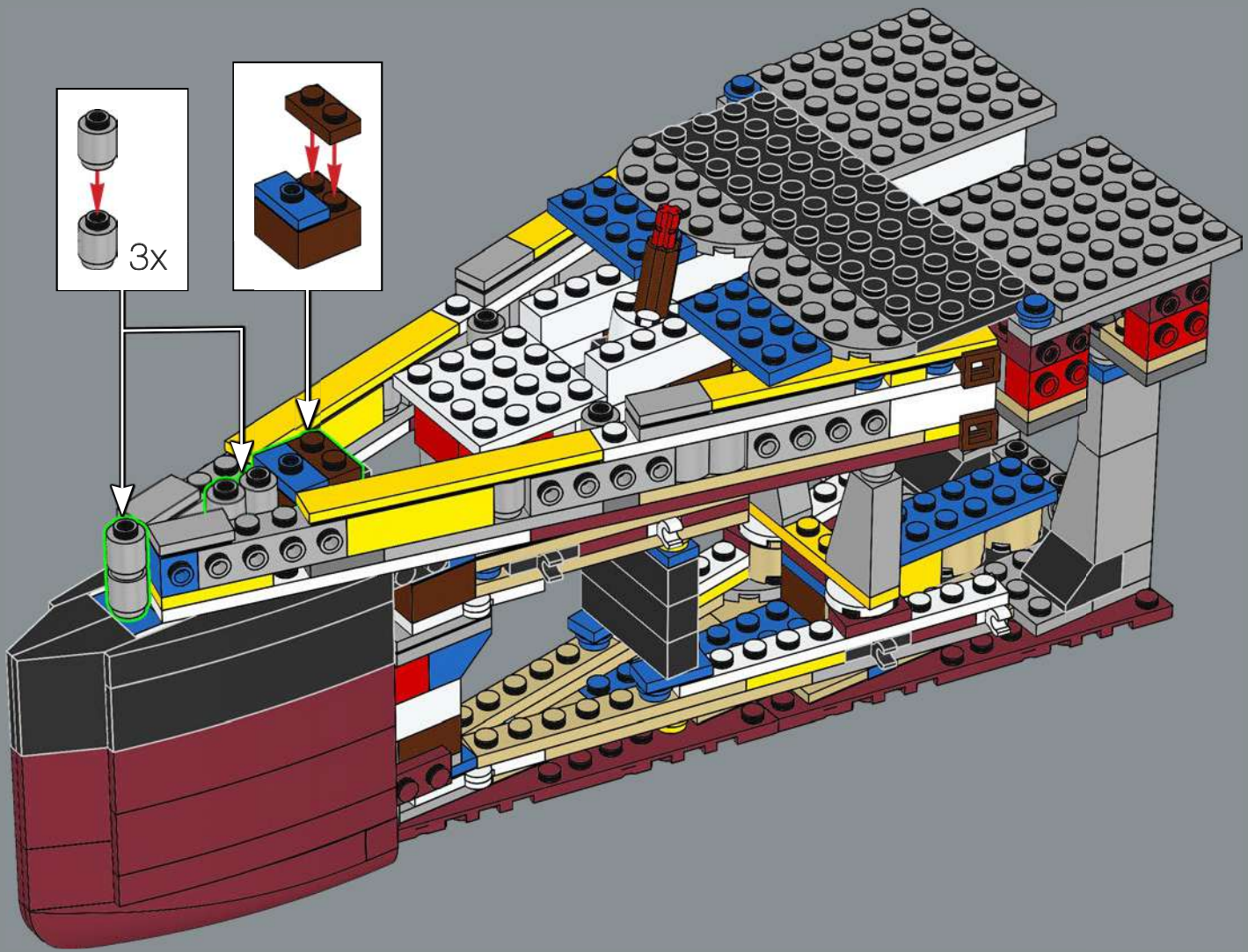

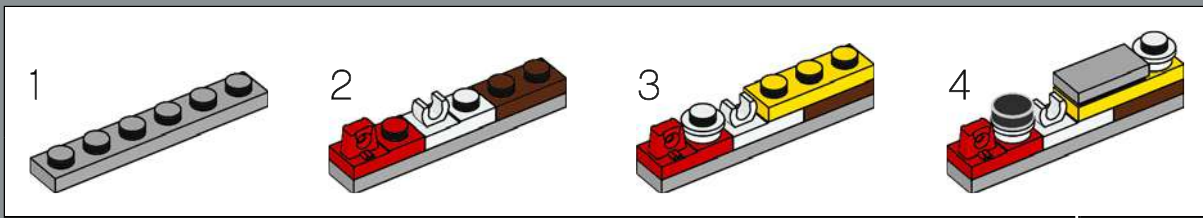
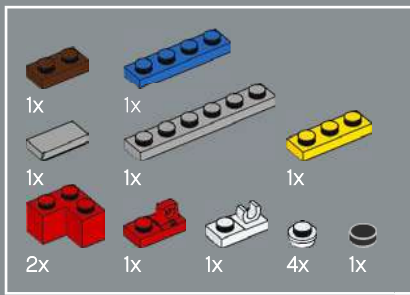

49

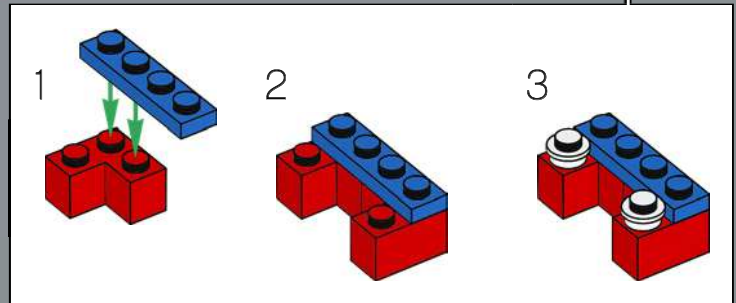
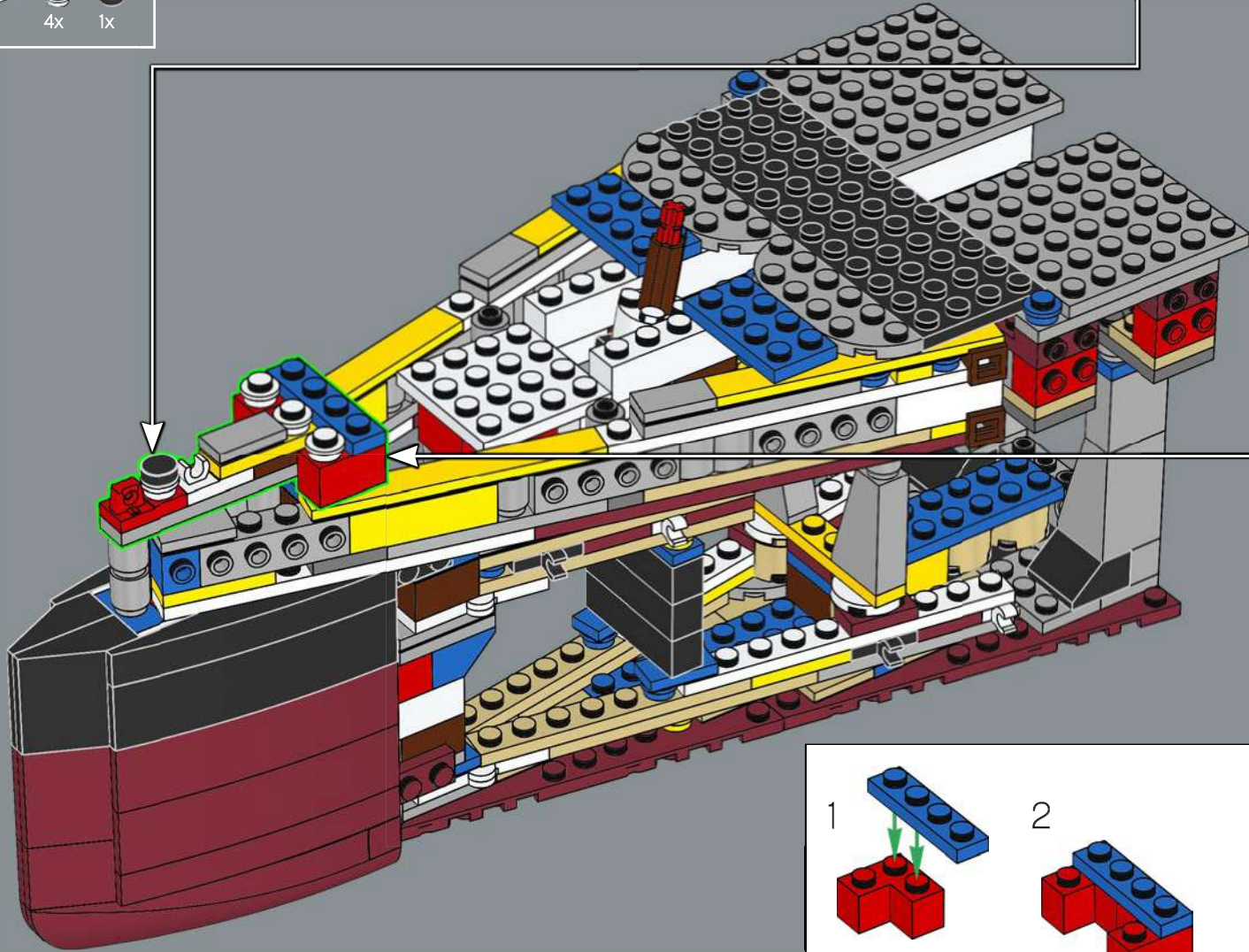

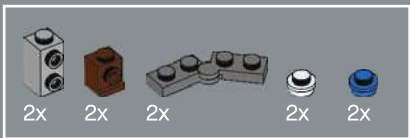

50

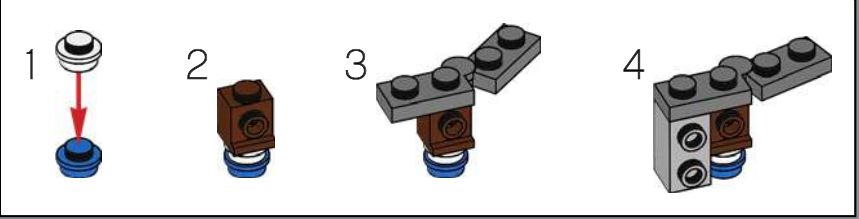
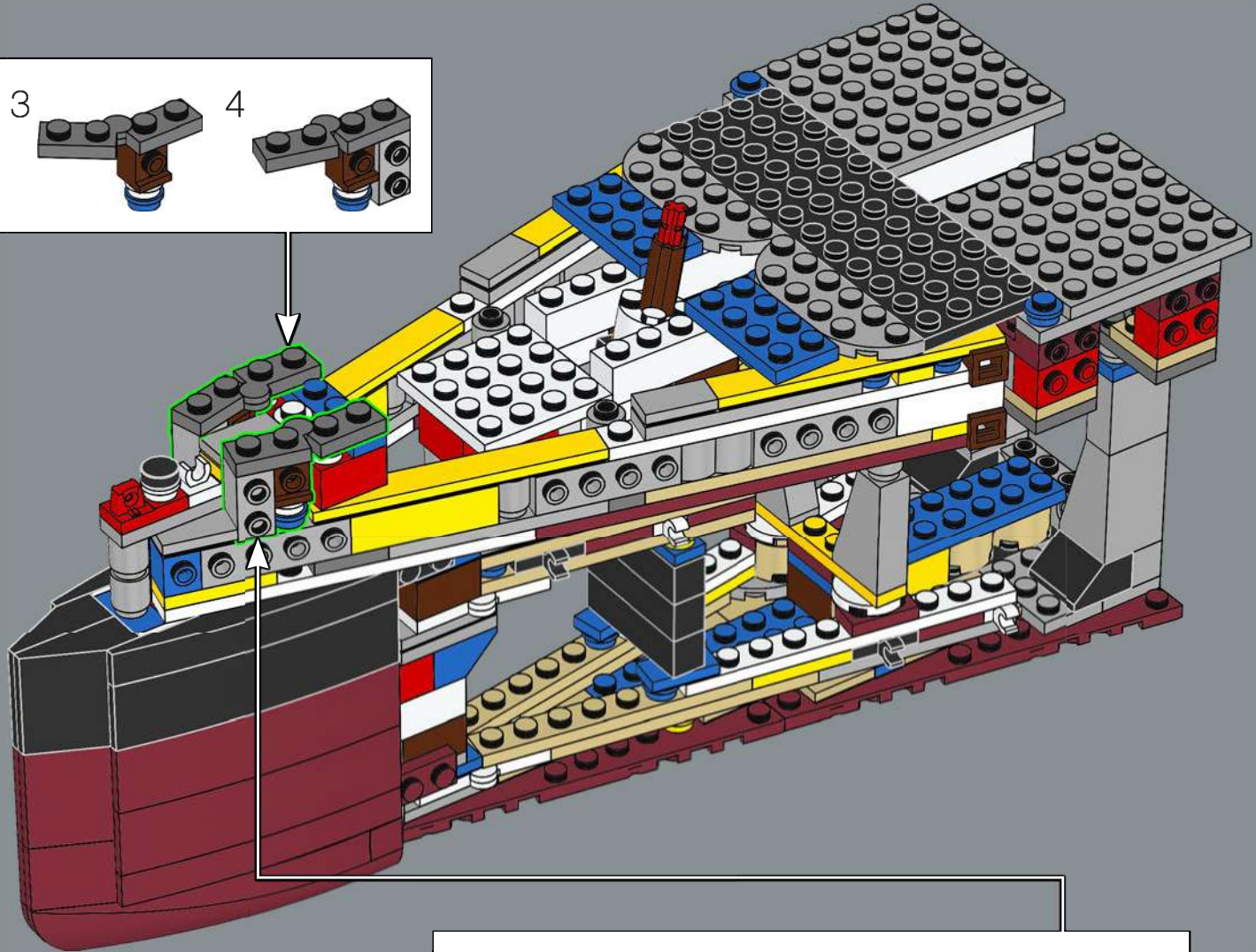
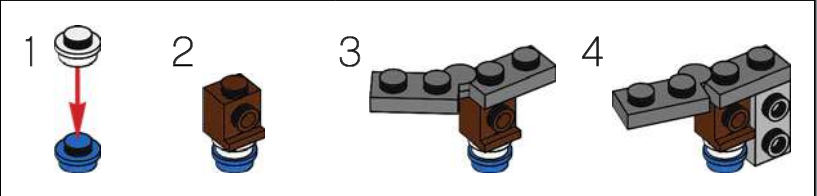

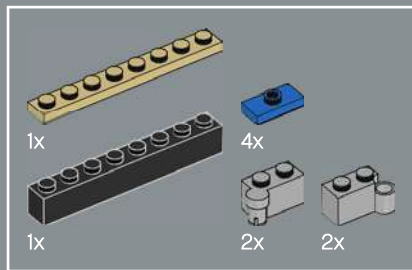

51

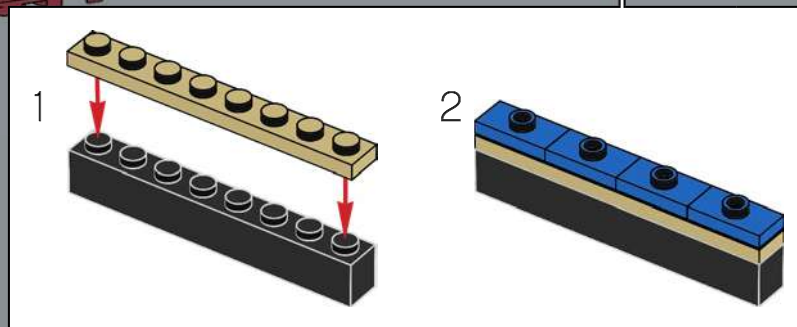
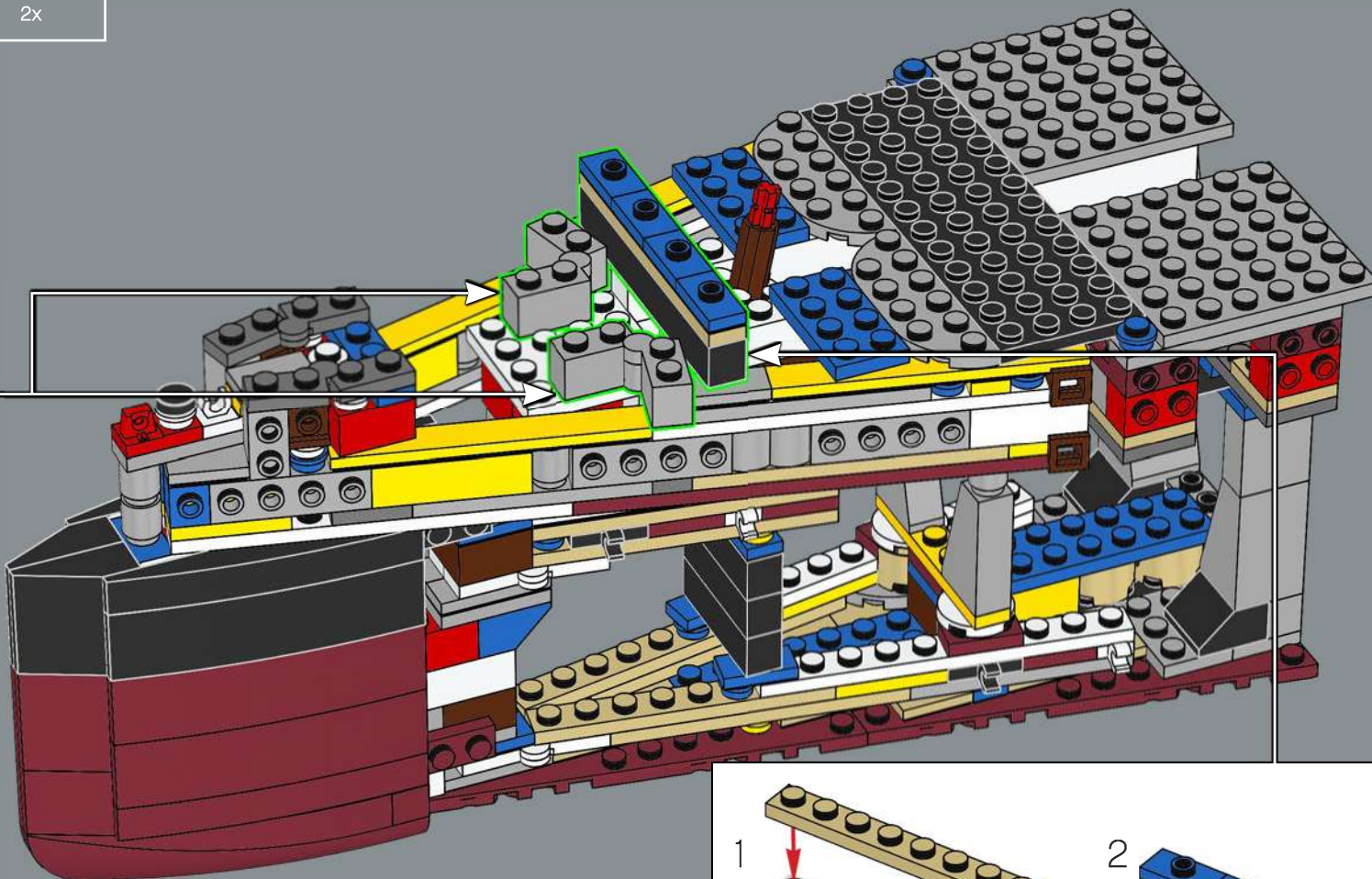
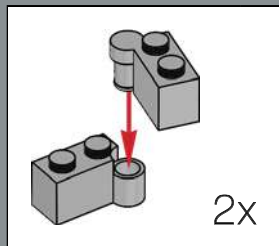

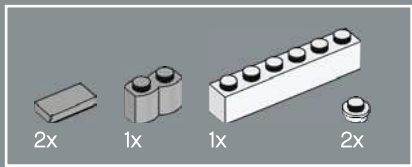

52

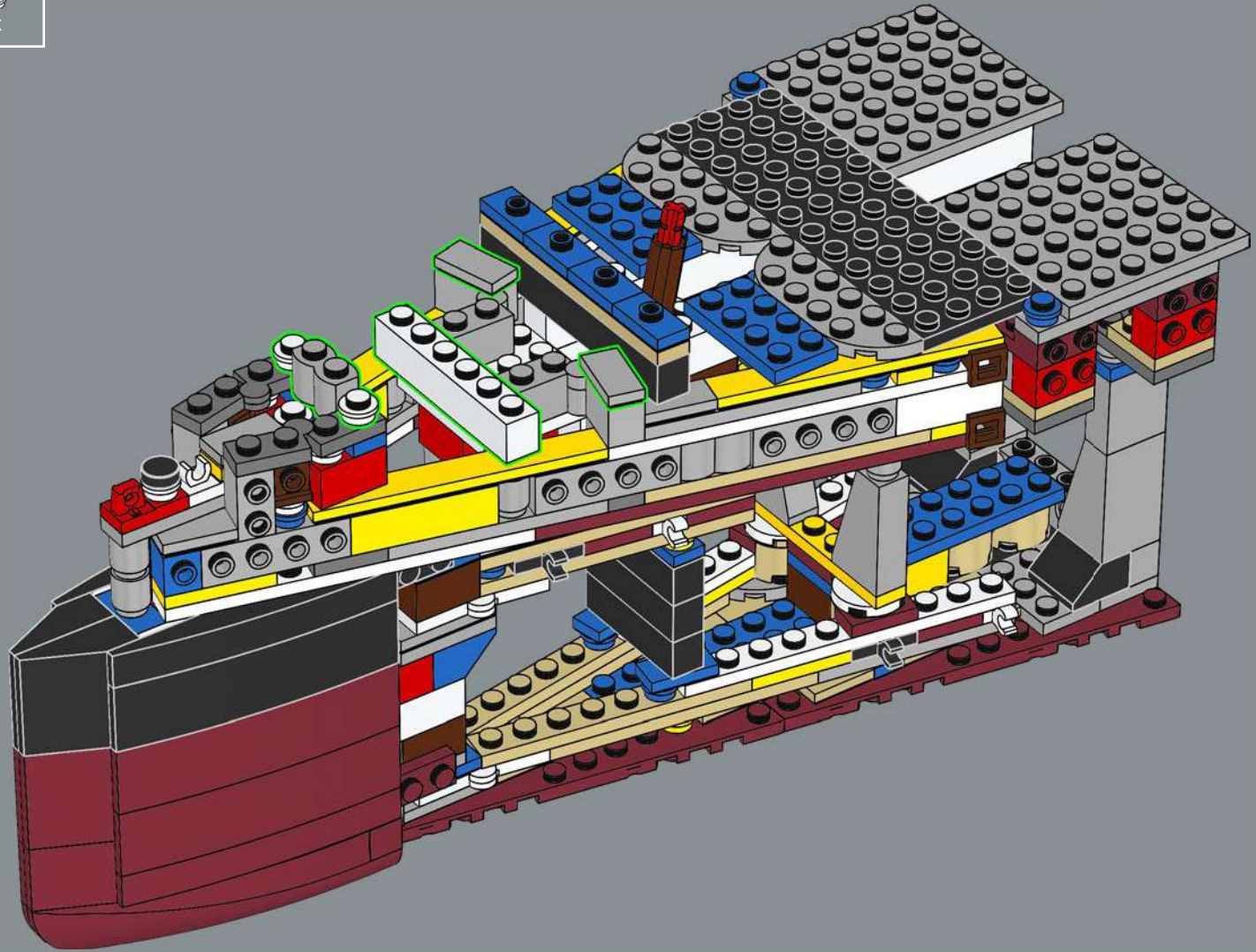

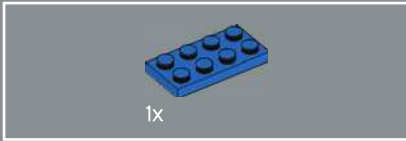
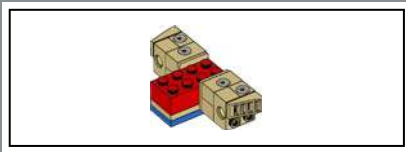

1x

53

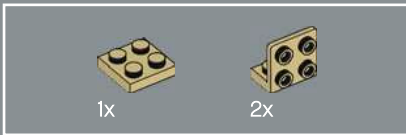
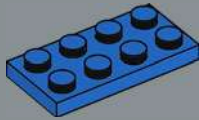

1x

2x

54

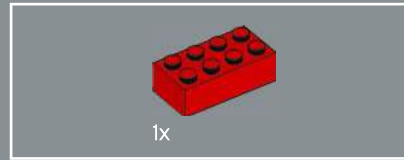
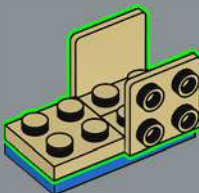

1x

55

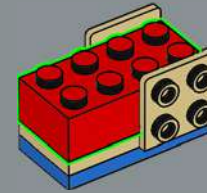

4x

2x

56

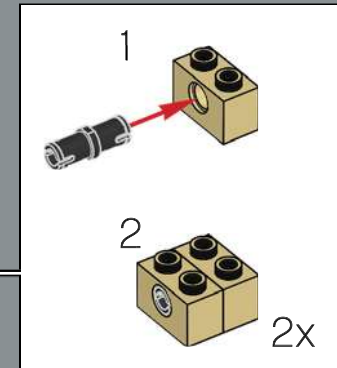

1

2

2x

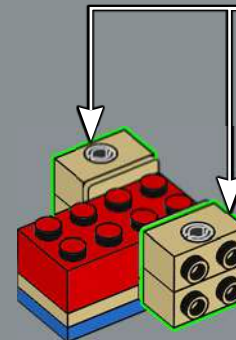



57

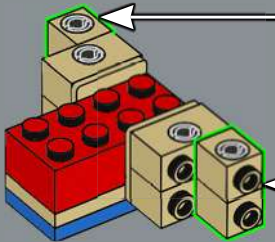
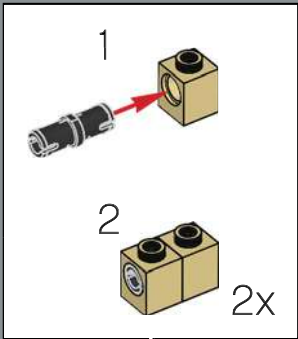

58

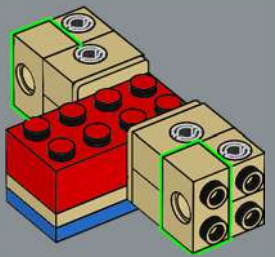

59

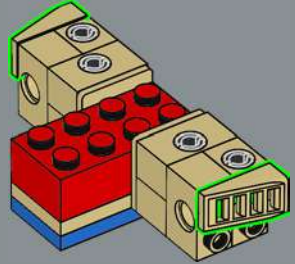

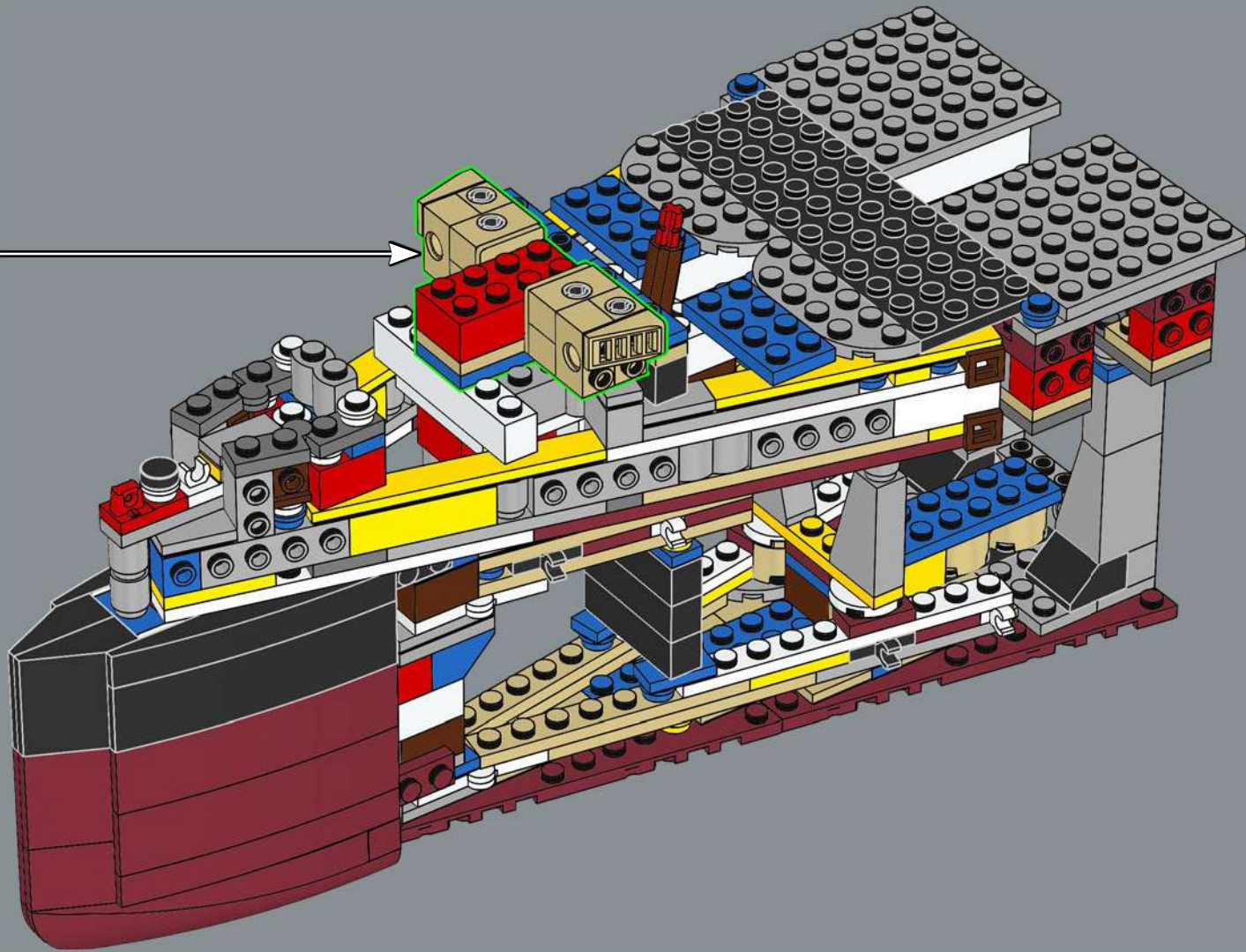

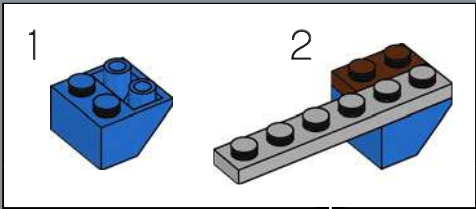
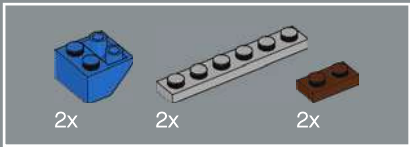

61

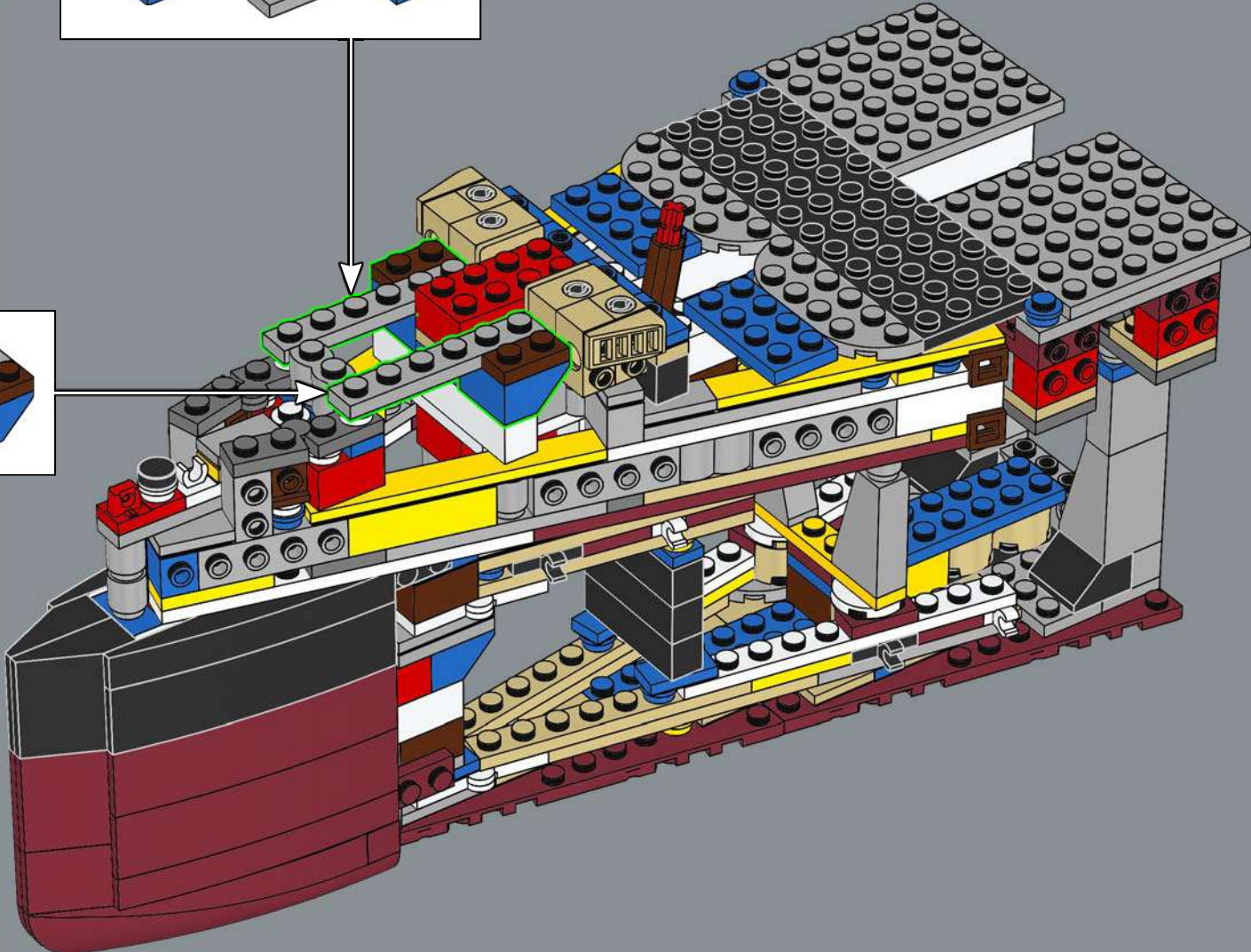
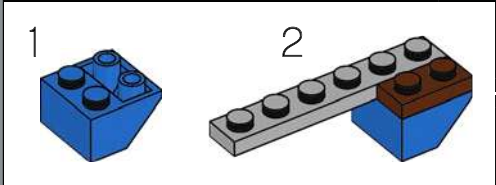

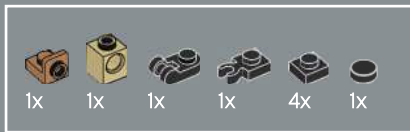

62

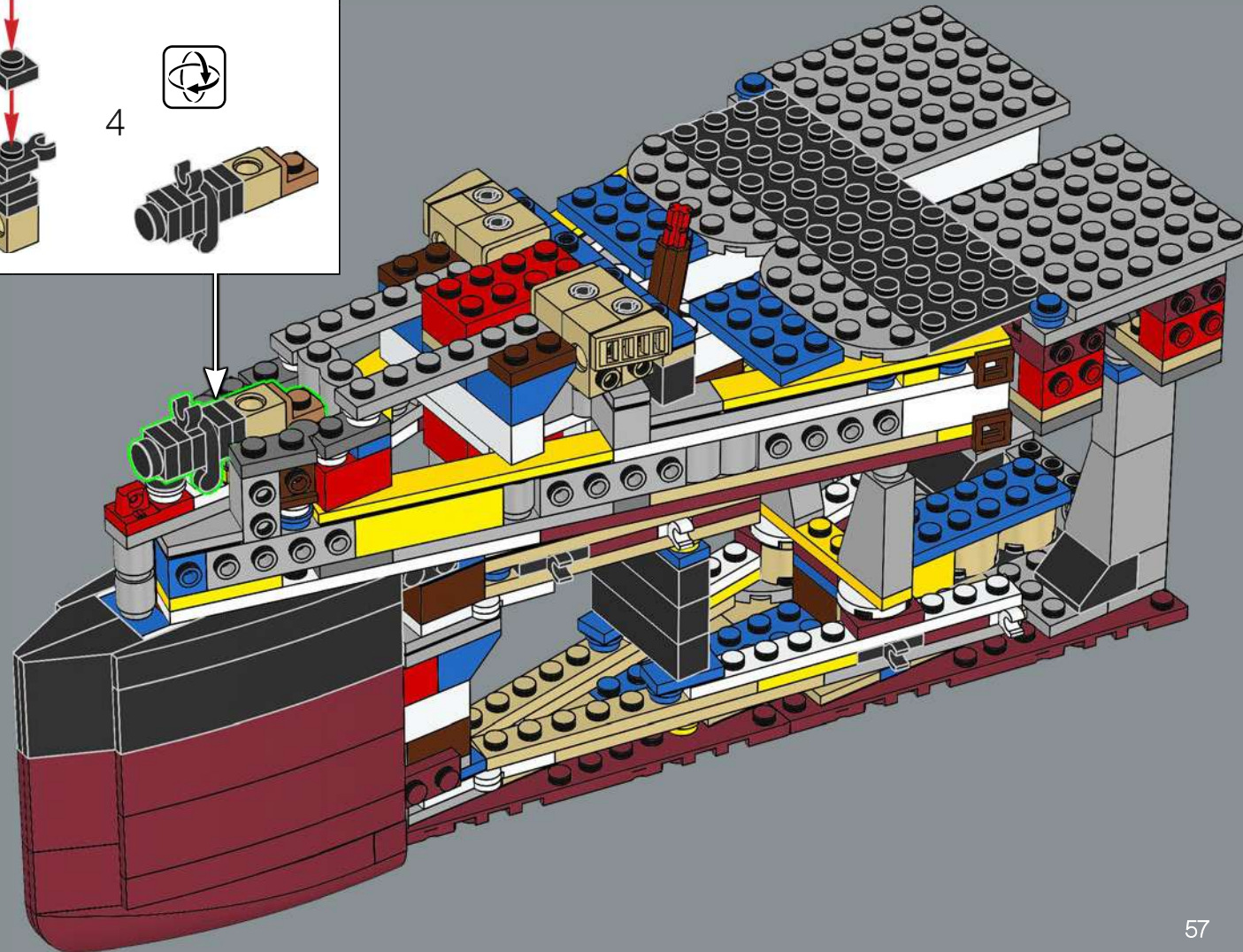
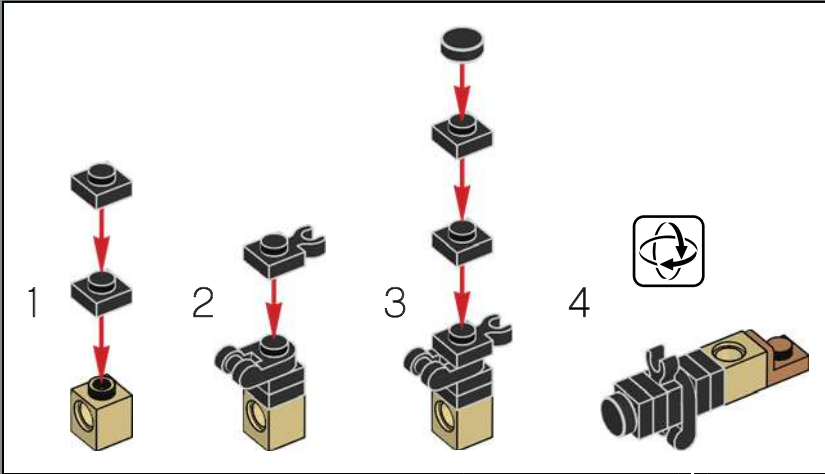

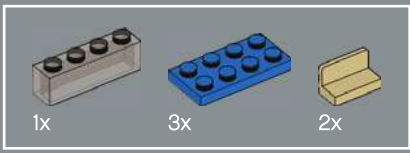

63

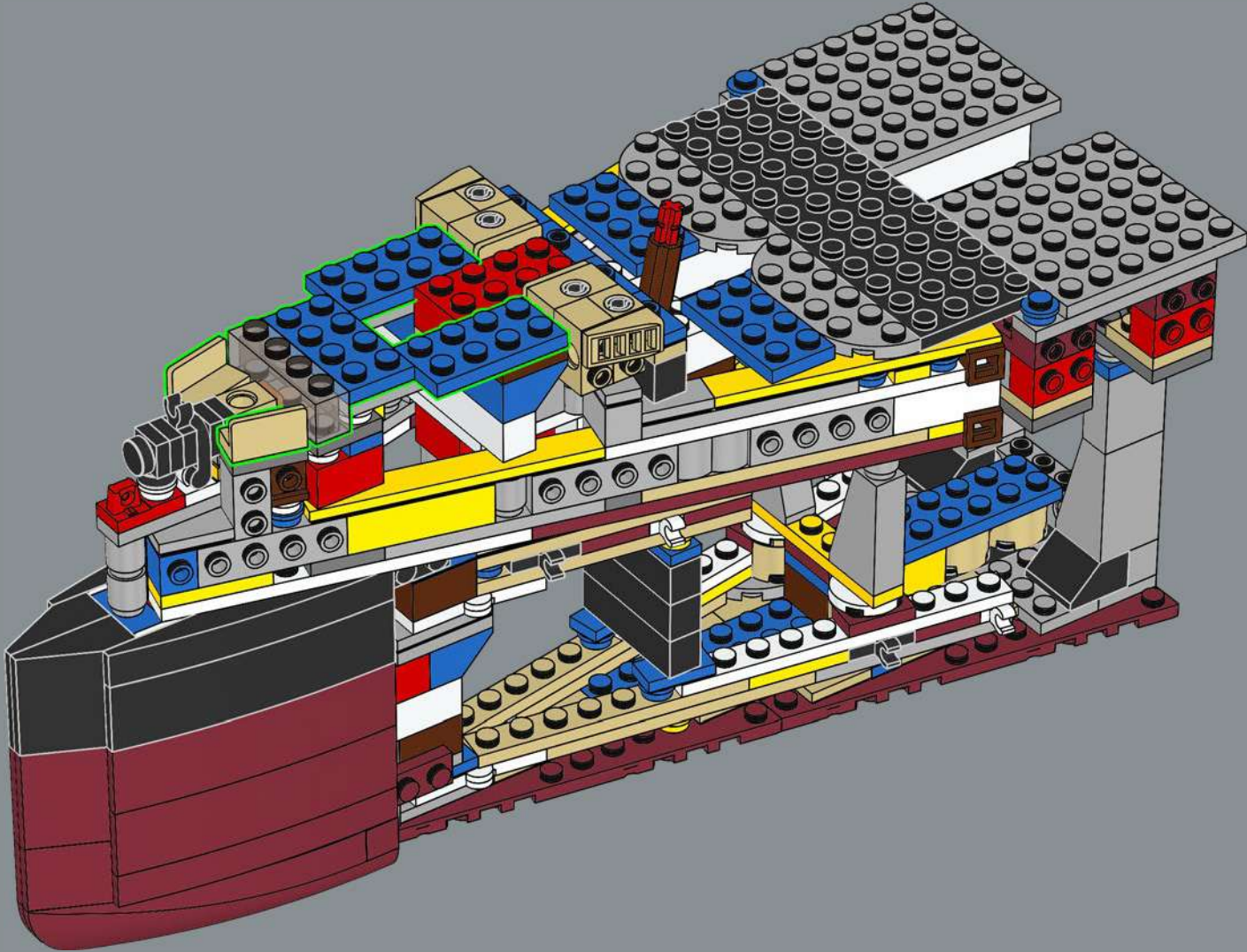

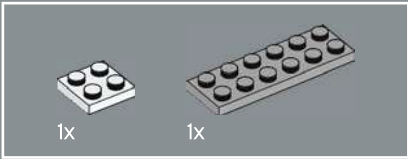
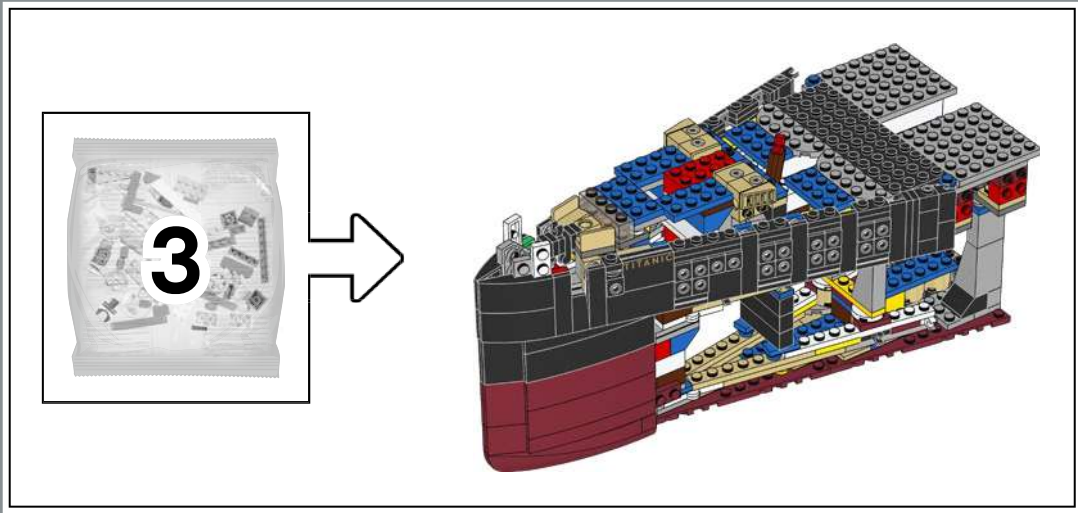

65

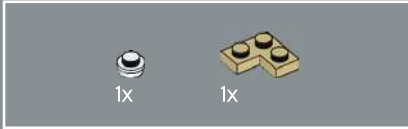
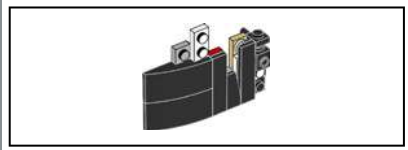

64

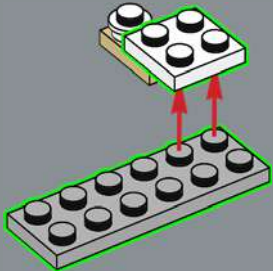
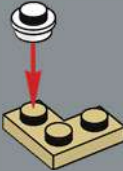

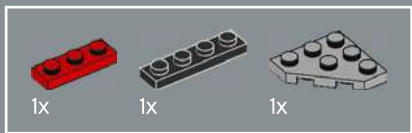

66

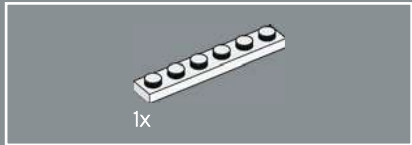
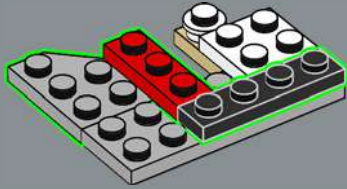

67

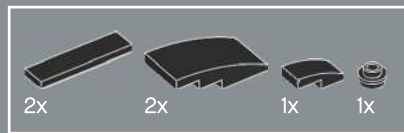
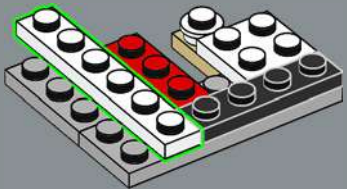

68

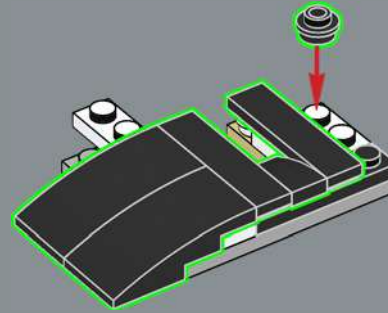

69

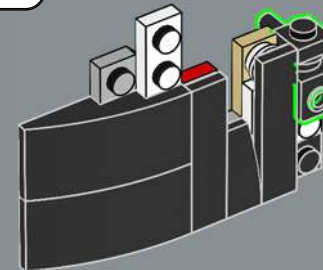
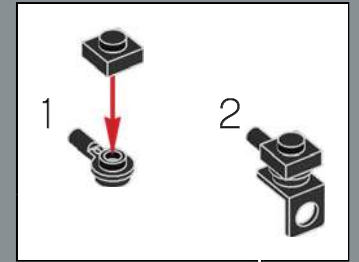

70

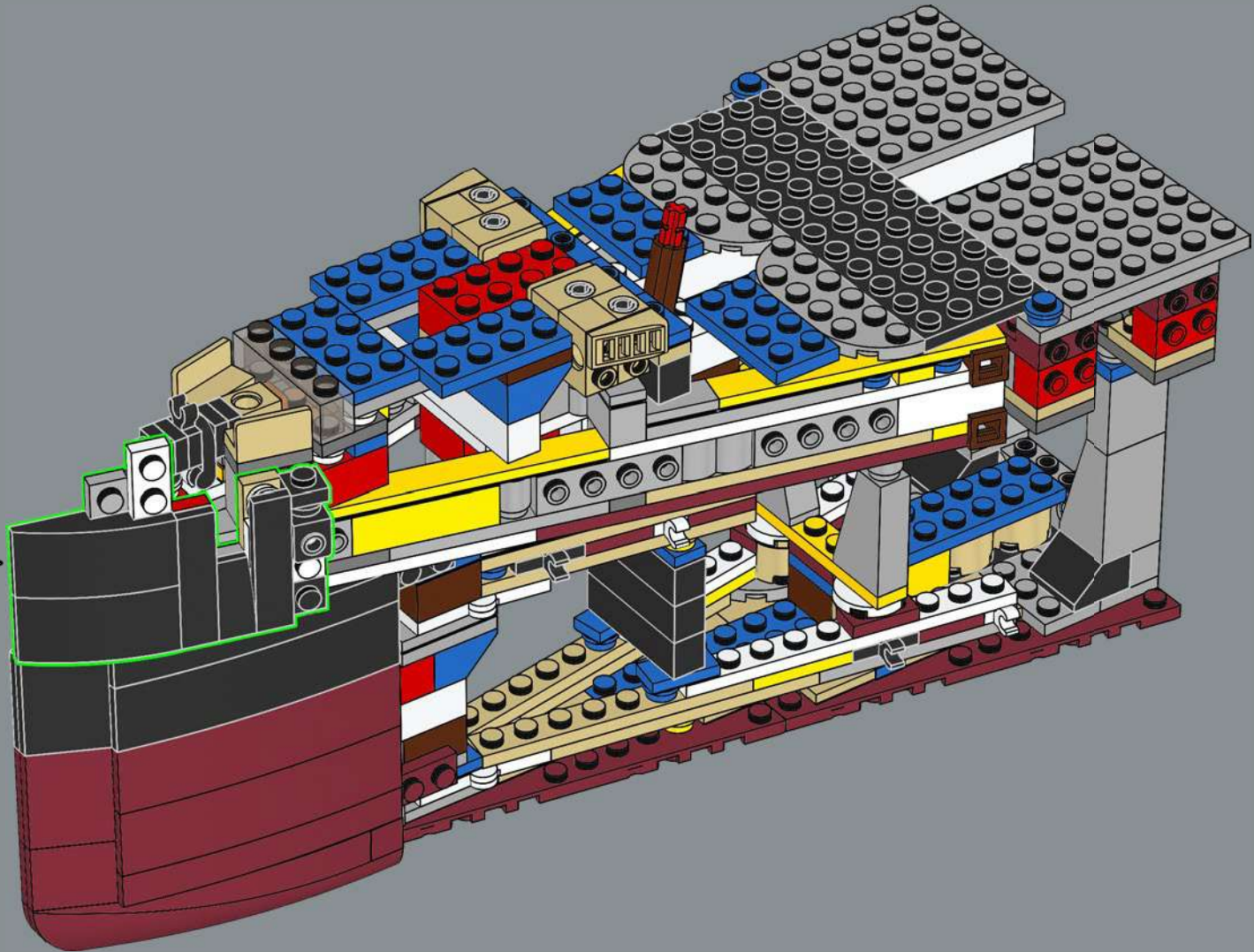

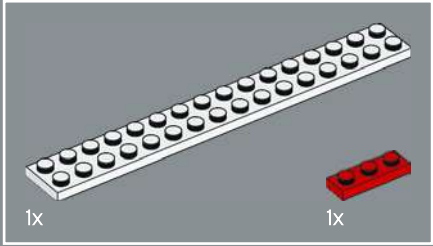
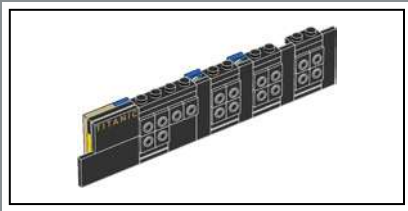

71

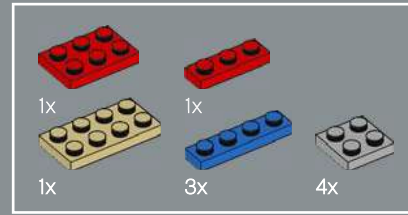
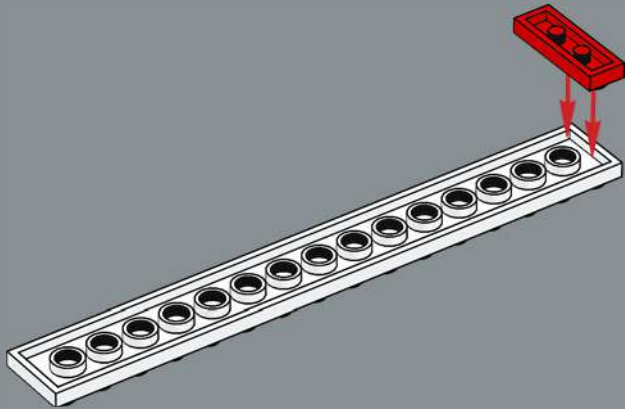

72

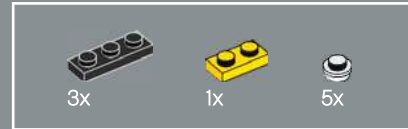
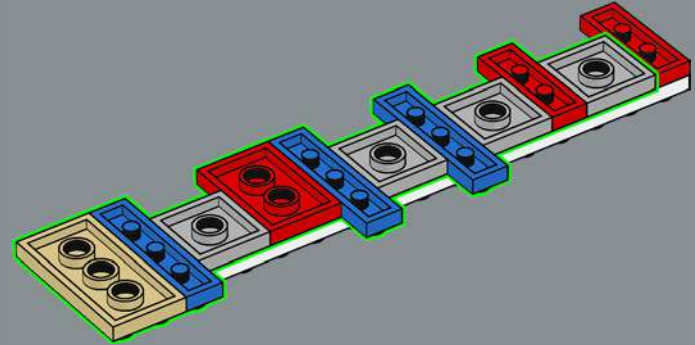

73

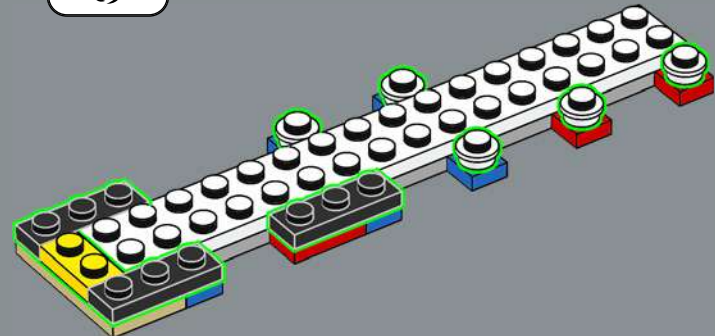

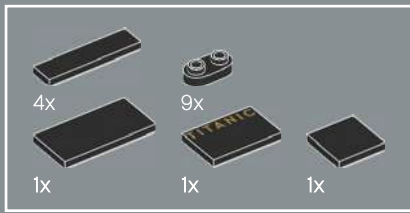

74

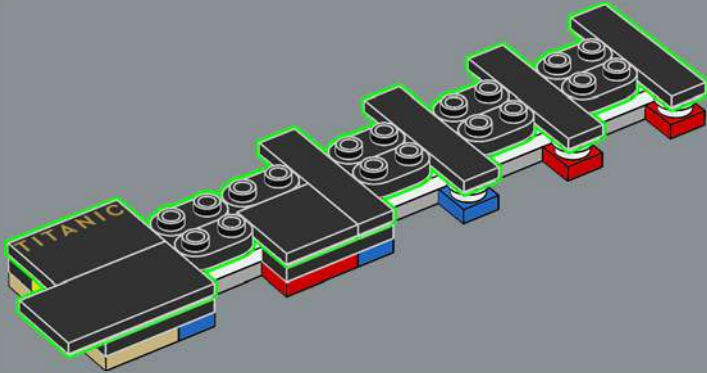

75

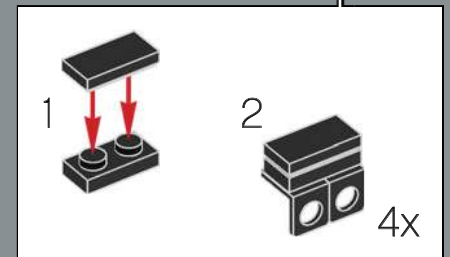
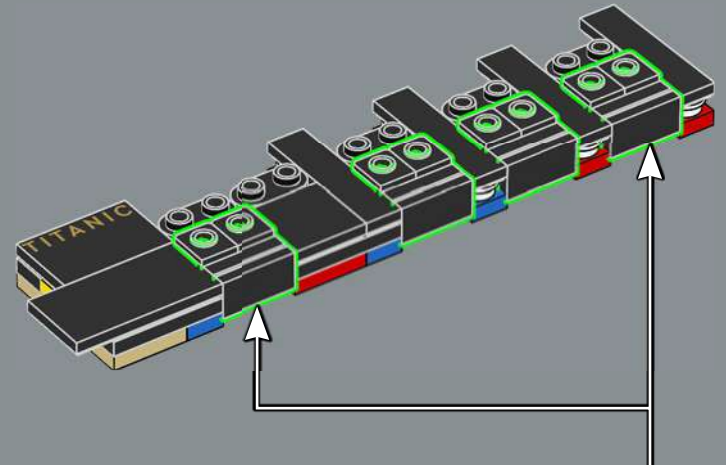

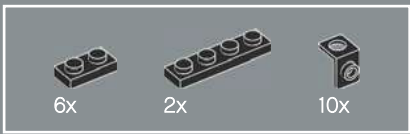

76

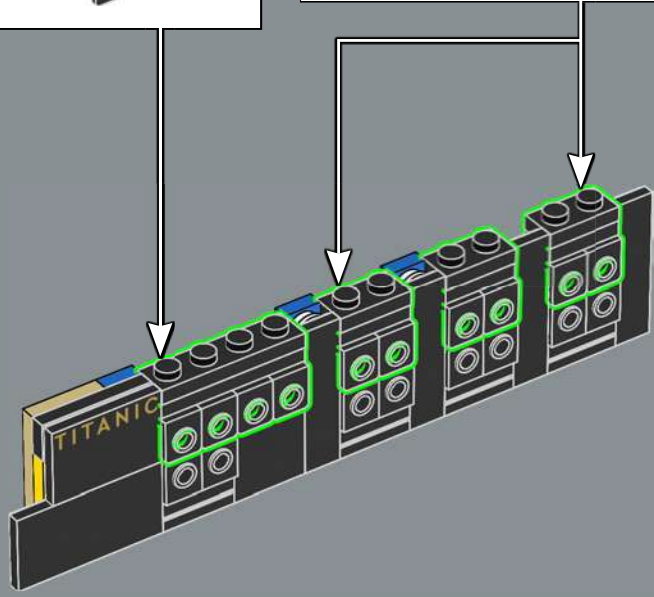
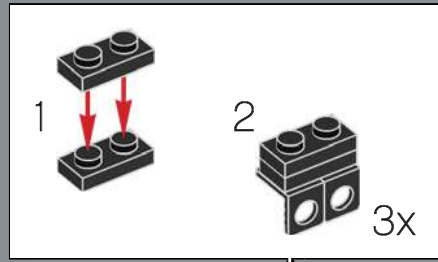
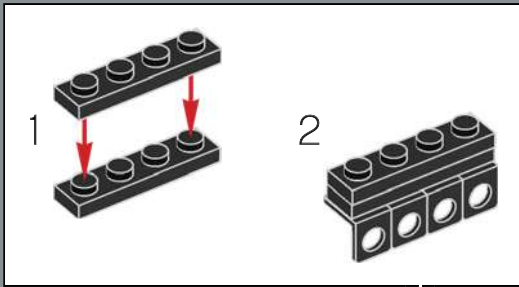

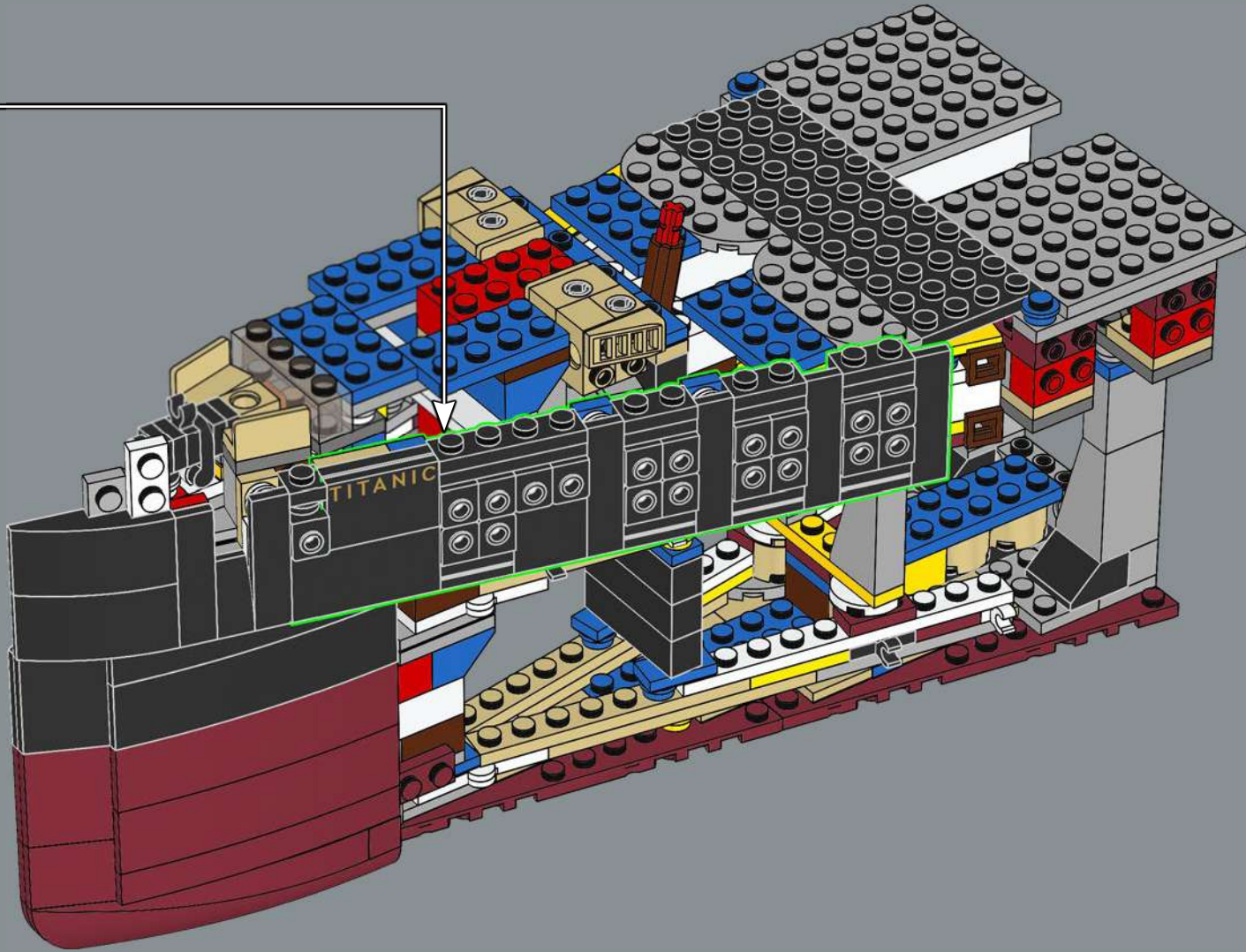

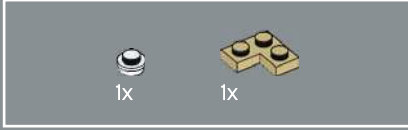
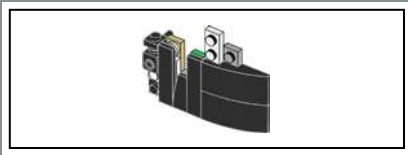

78

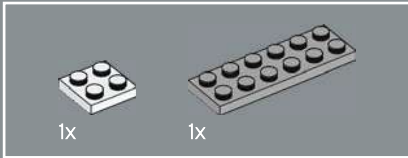
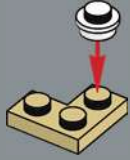

79

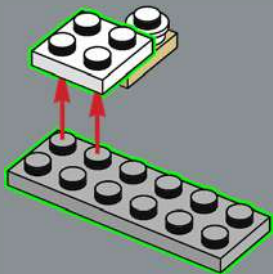

80

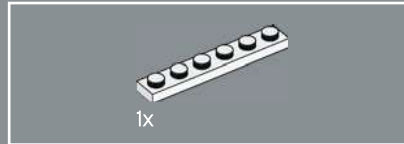
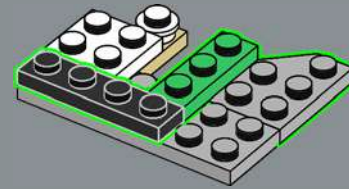

81

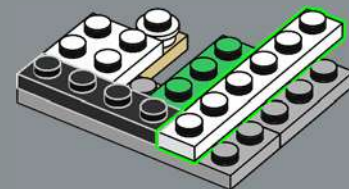



82

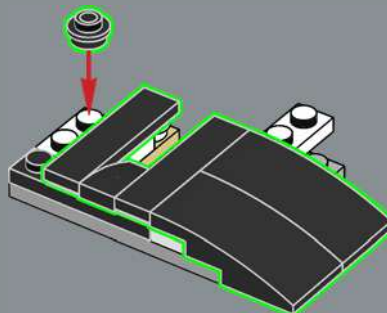

83

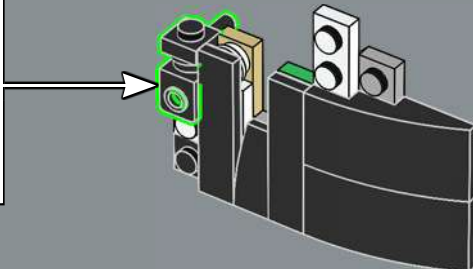
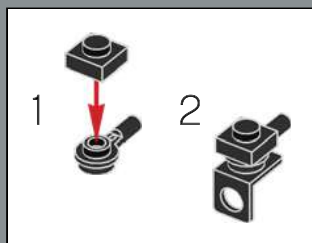

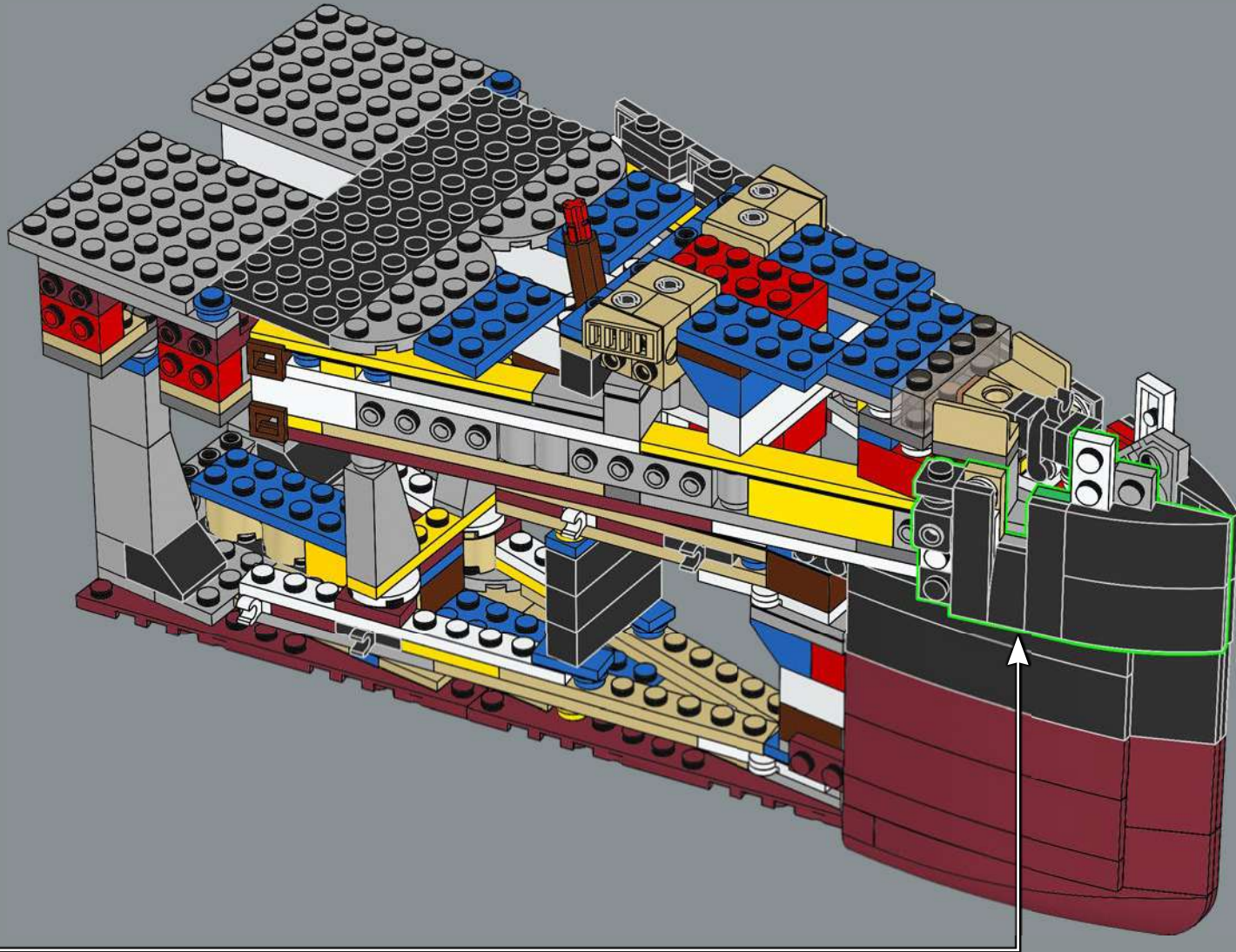

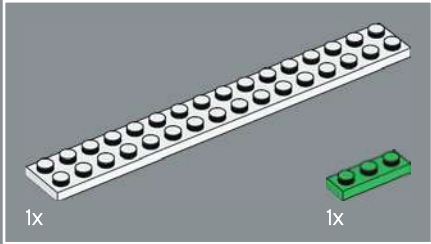
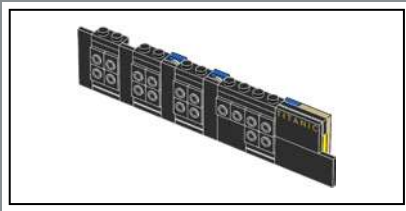

85

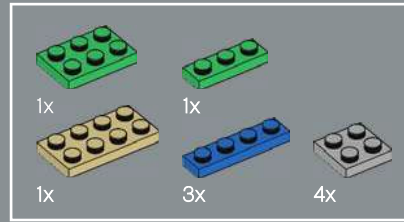
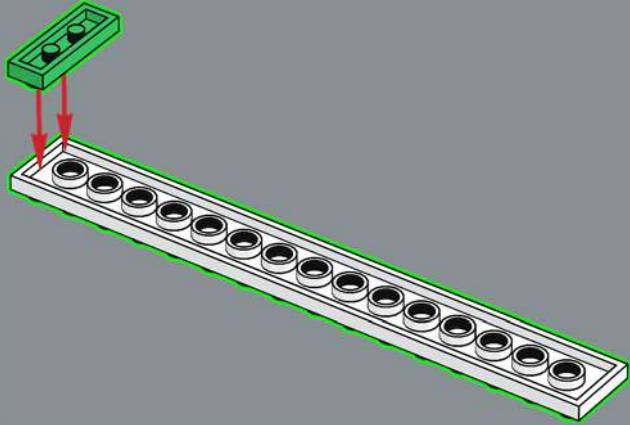

86

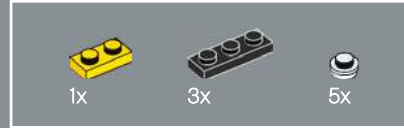
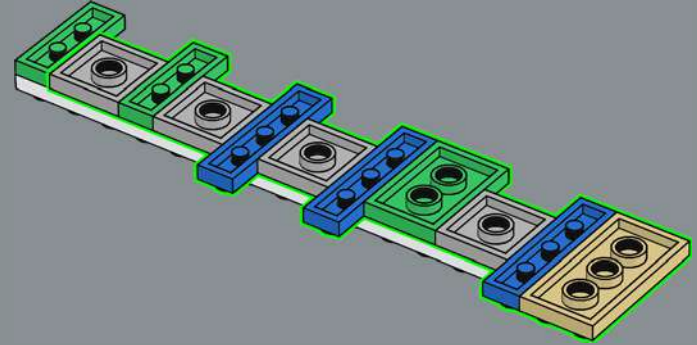

87

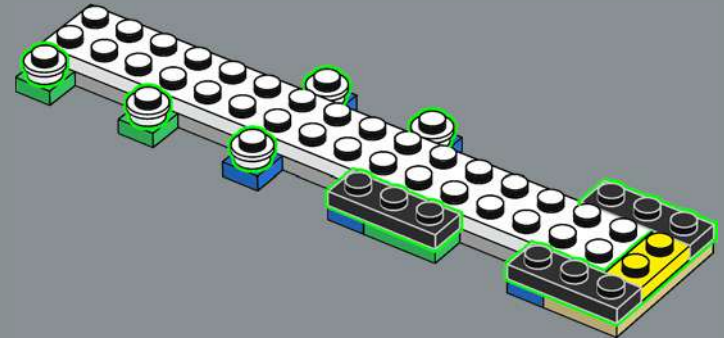

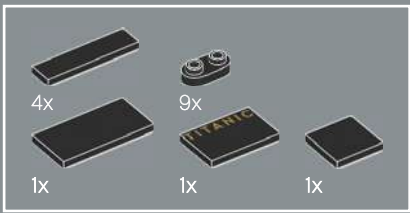

88

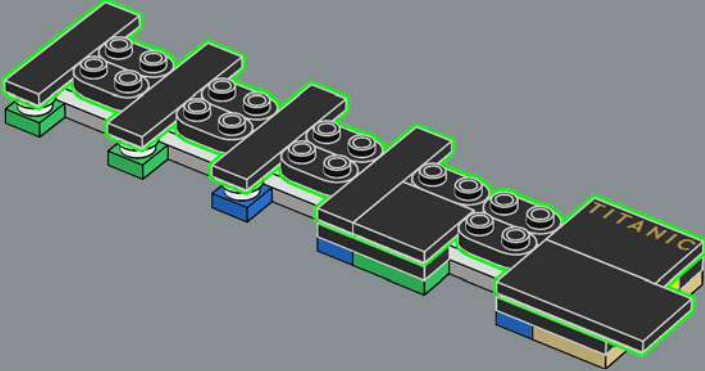

89

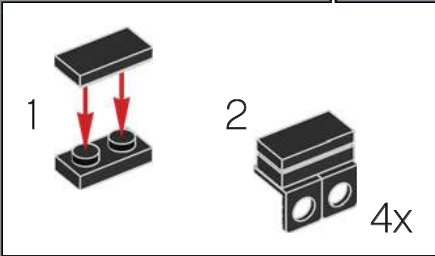
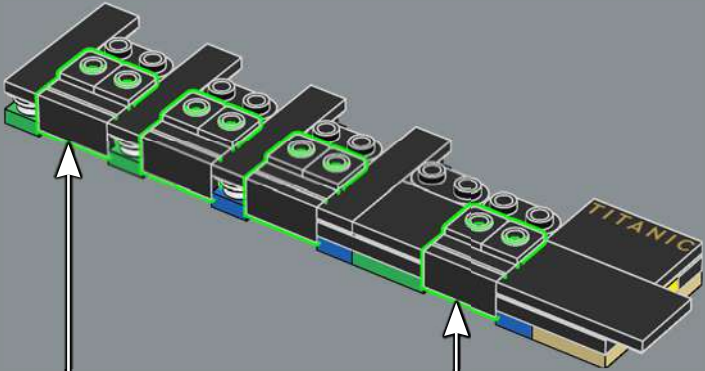

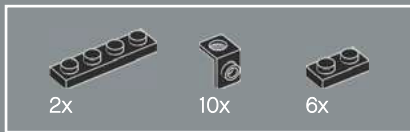

90

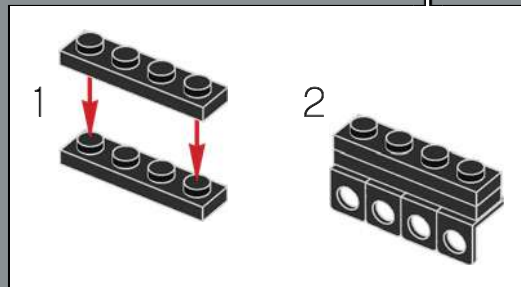
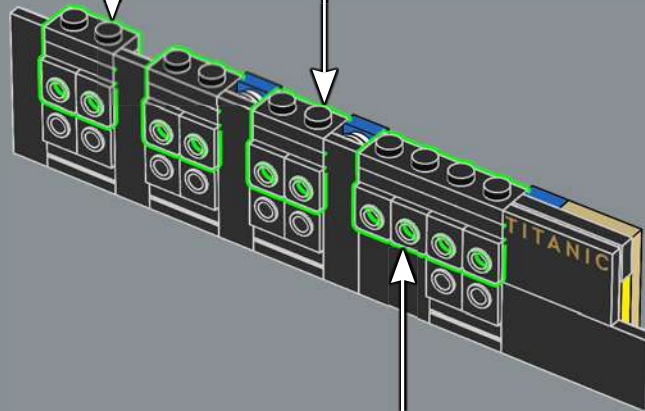
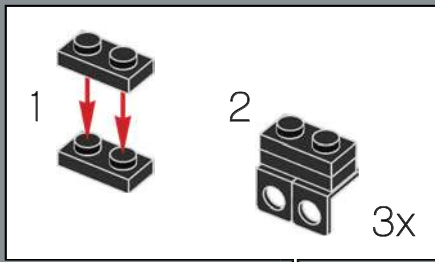

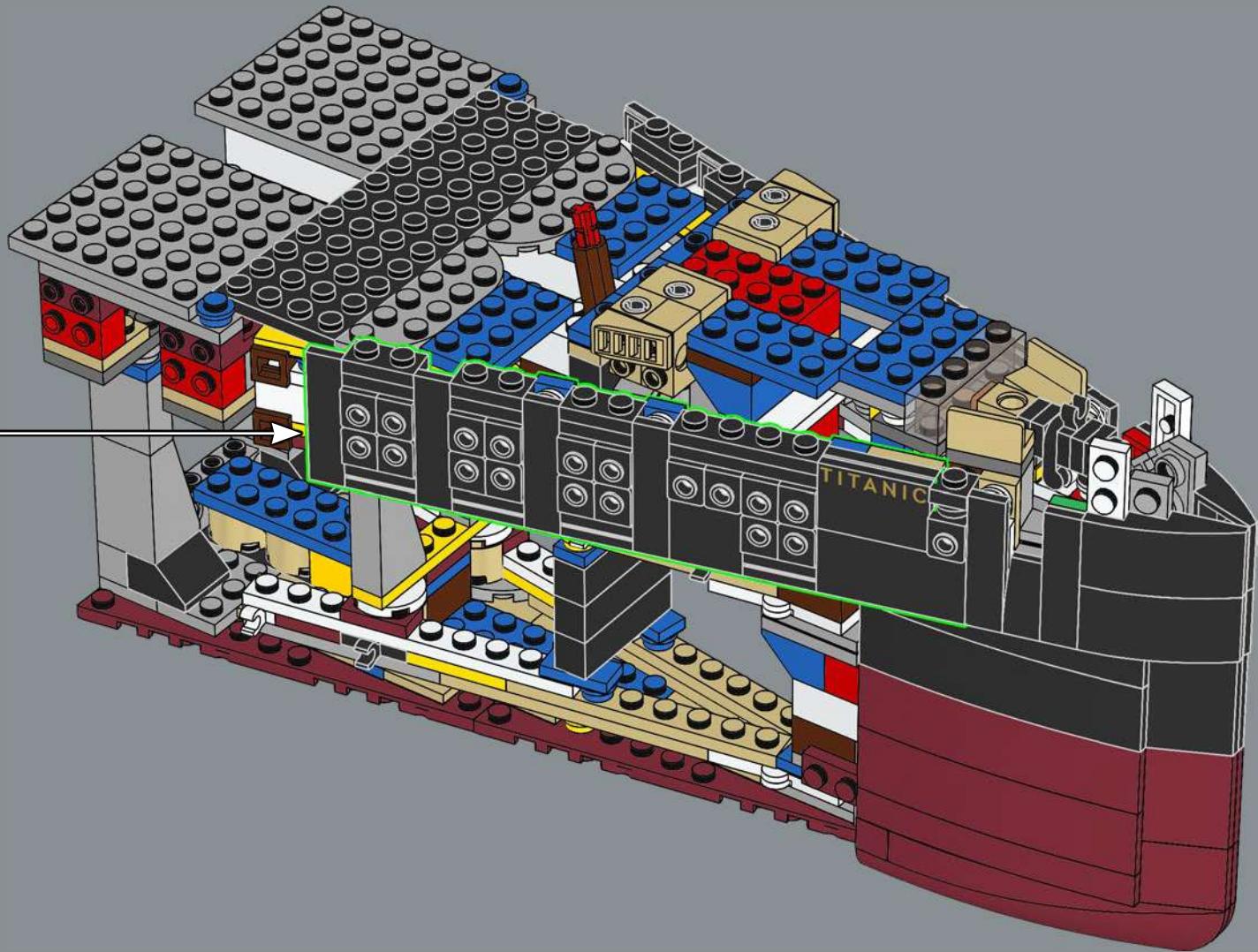

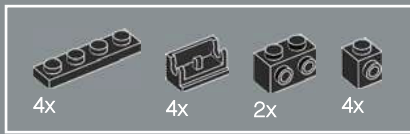

92

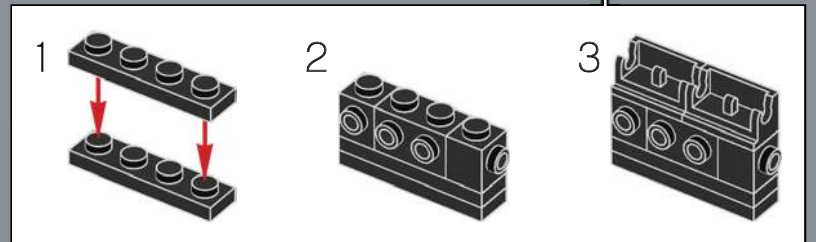
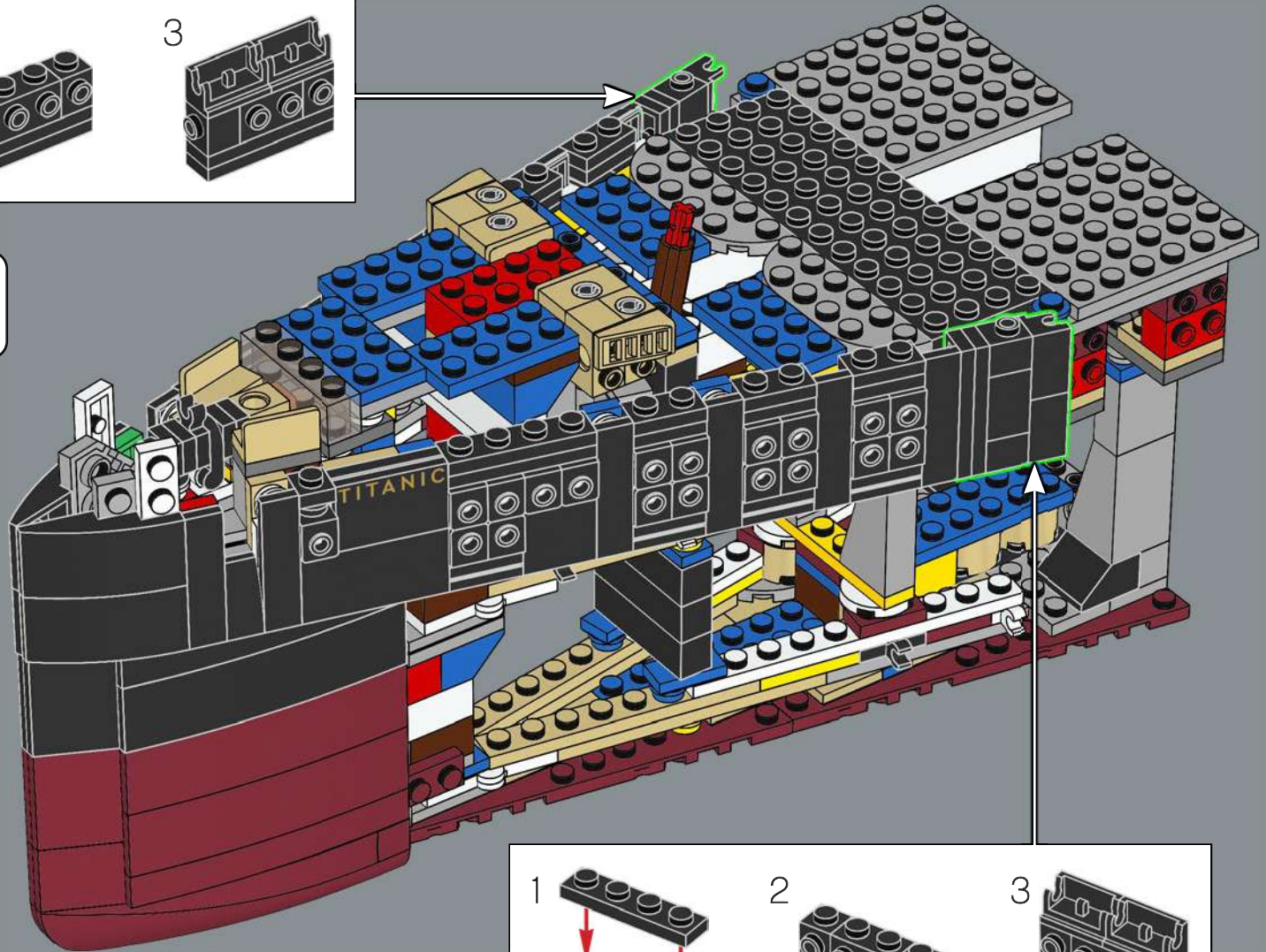
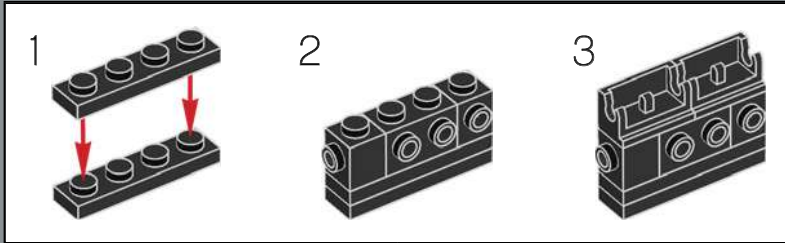

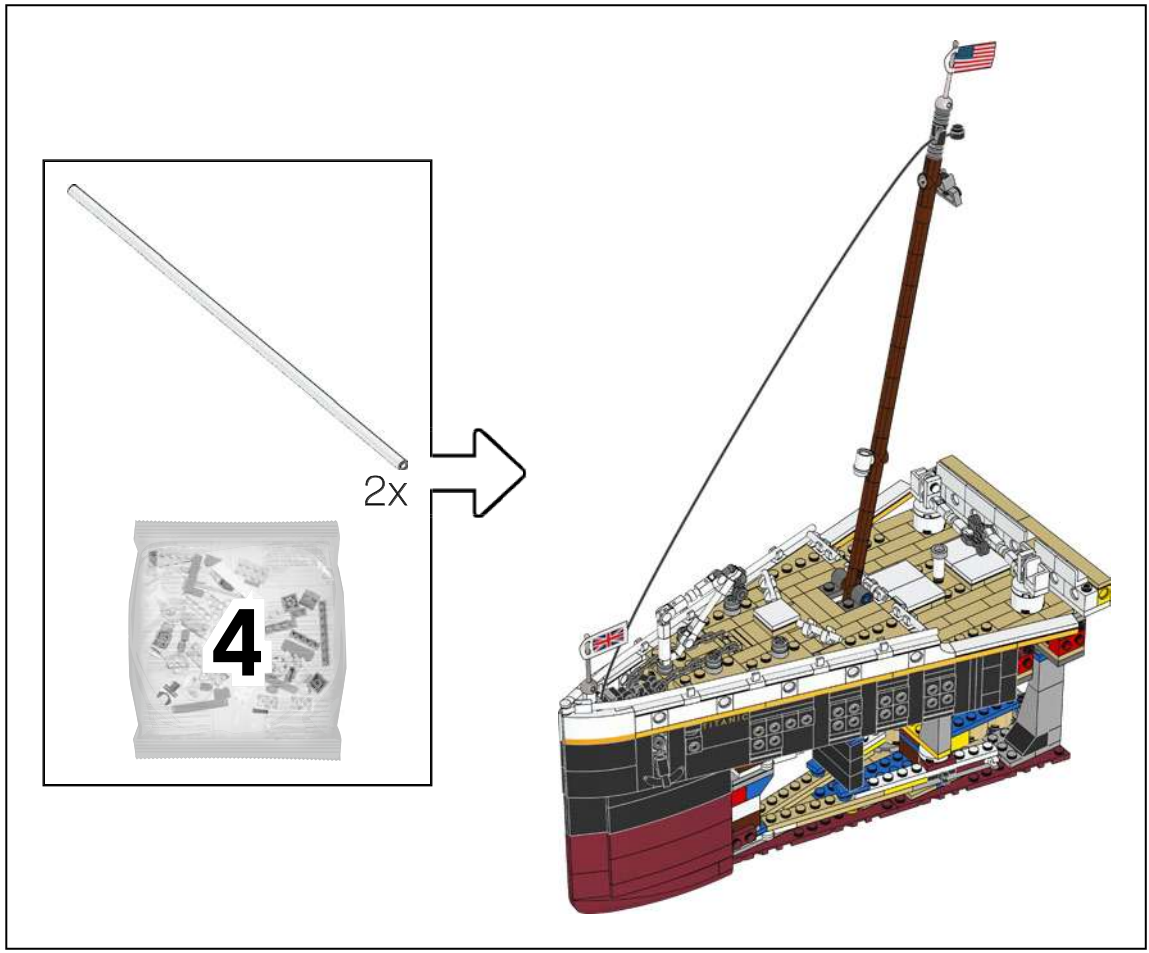

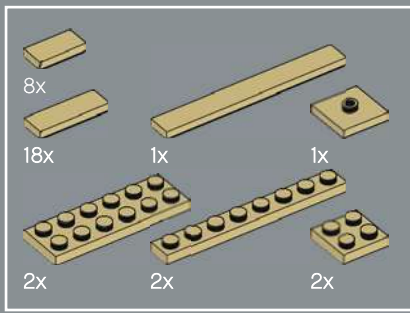

93

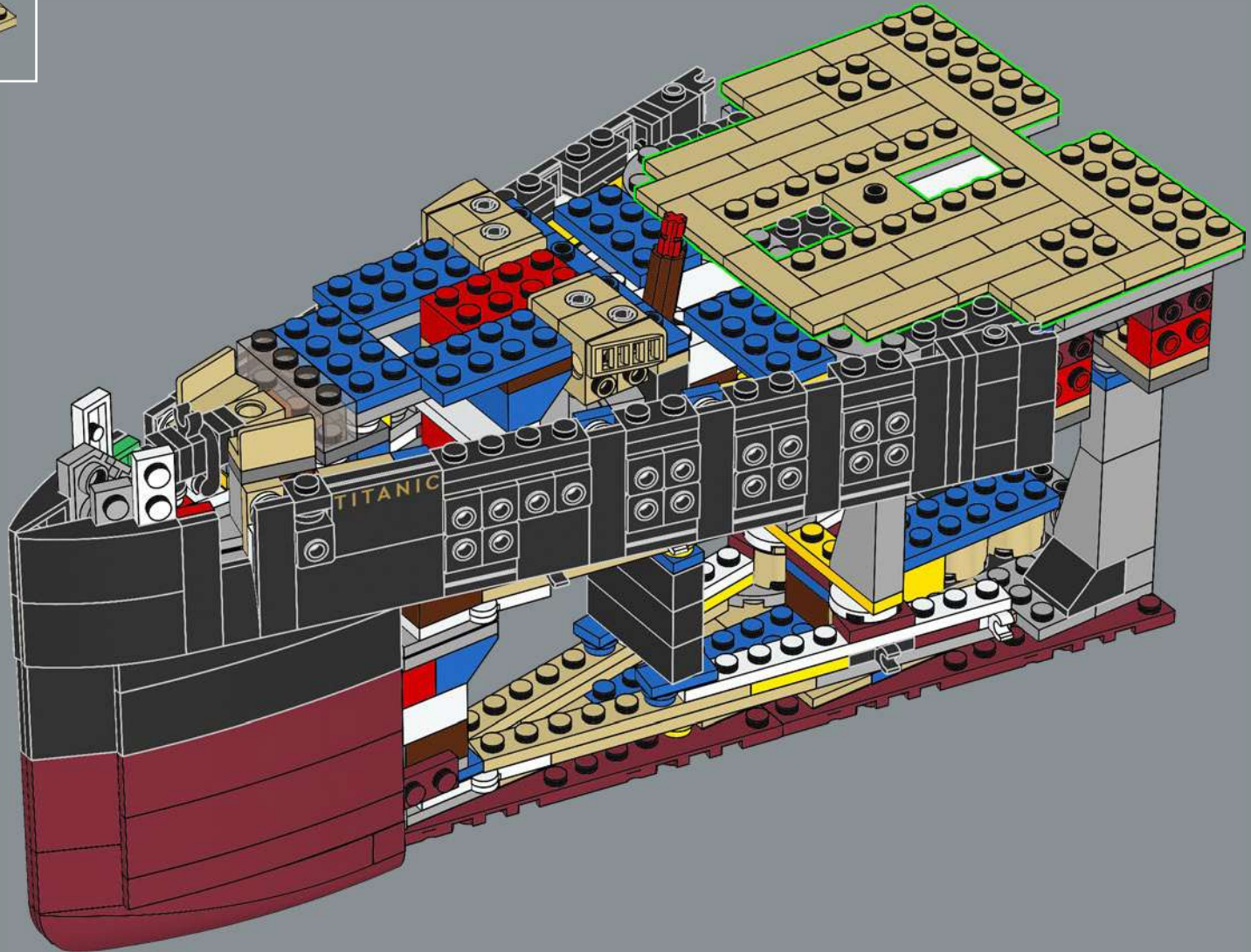

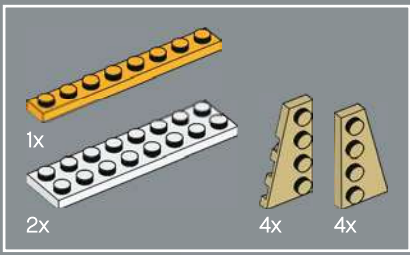

94

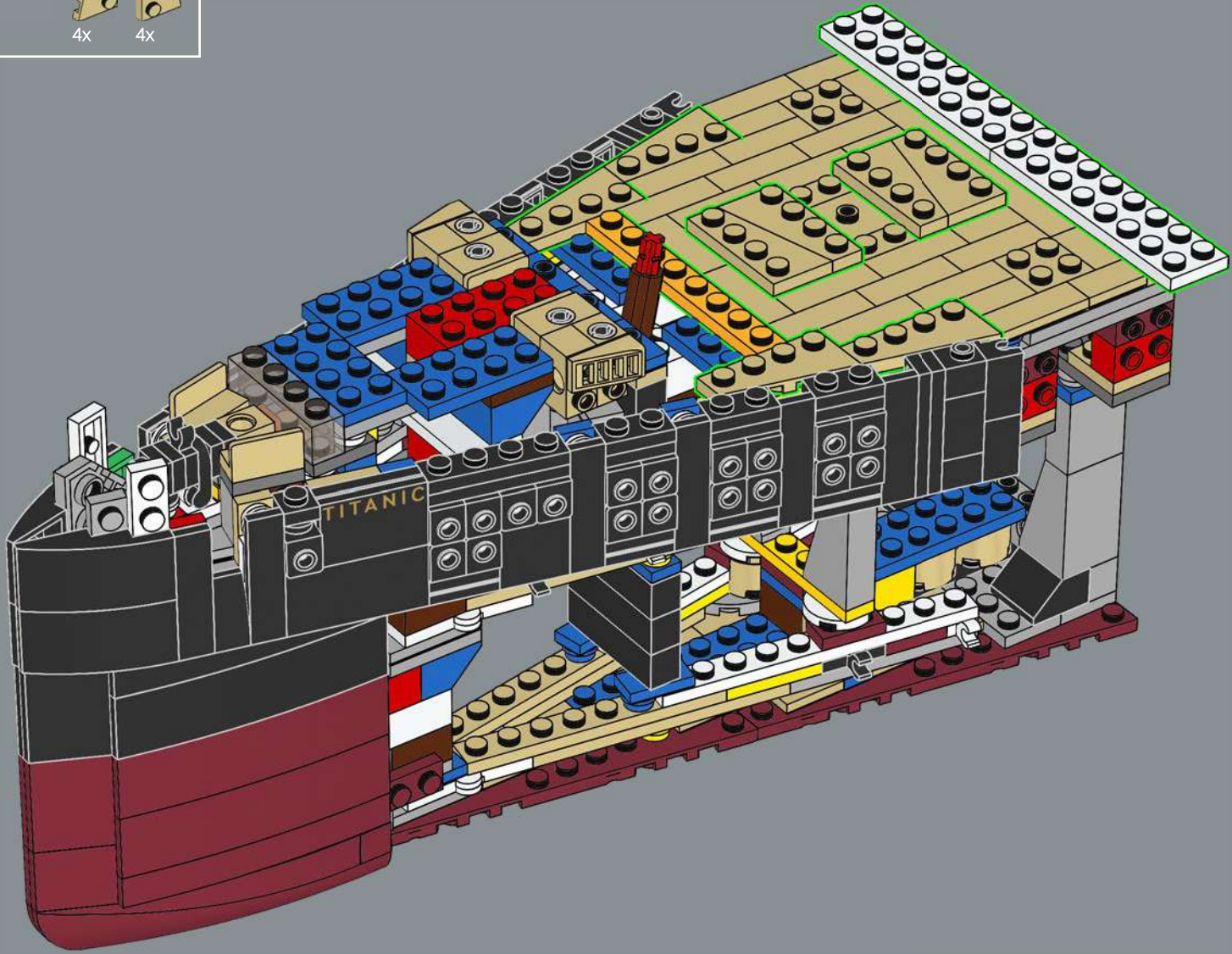

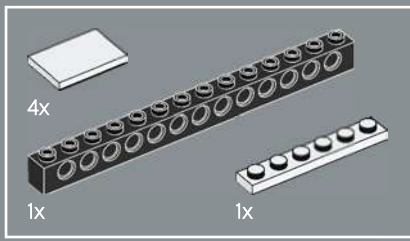

95

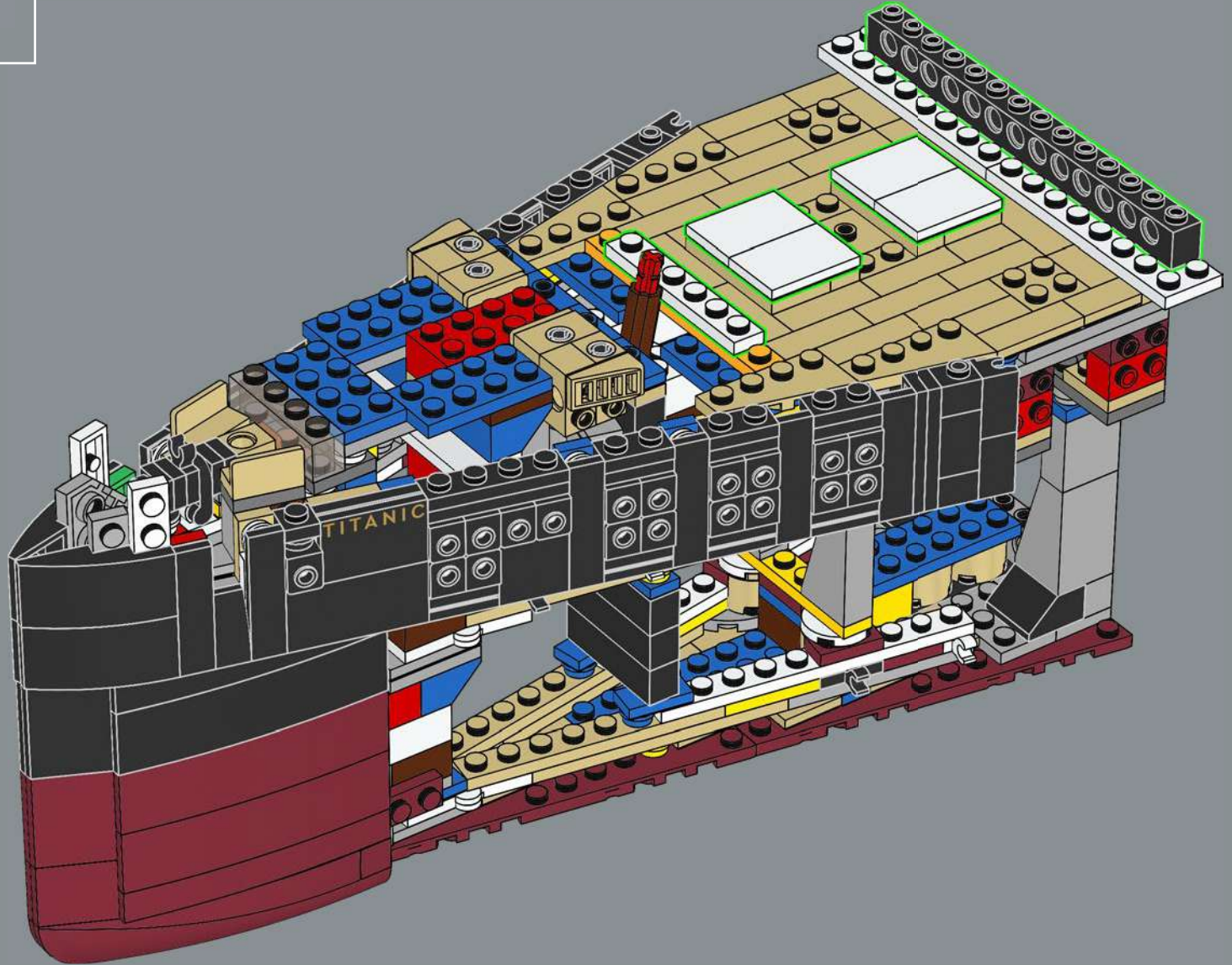

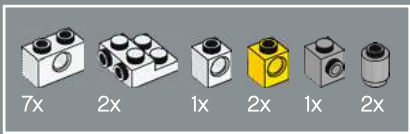

96

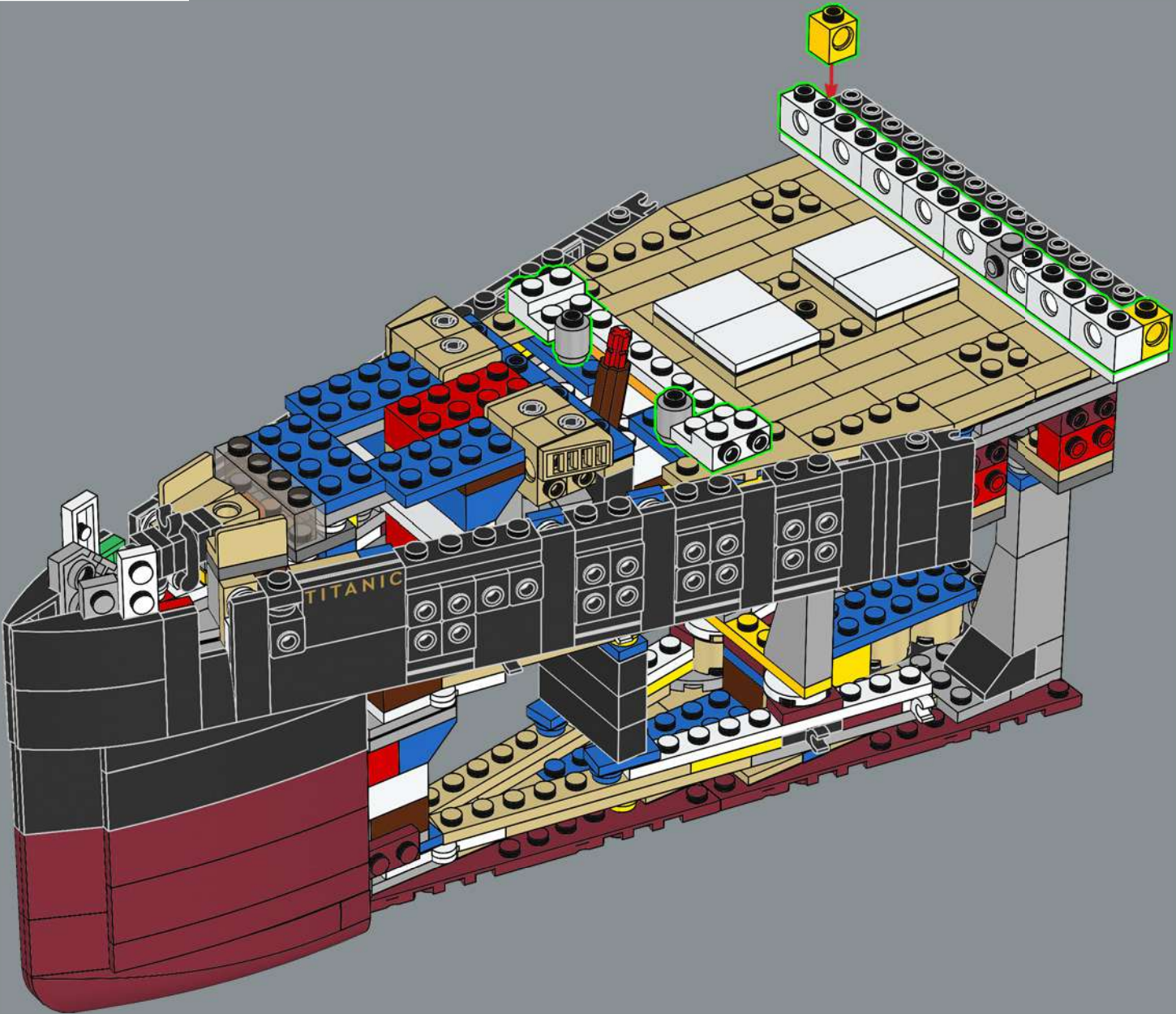

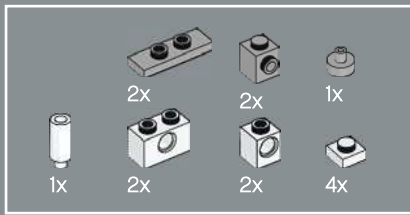

97

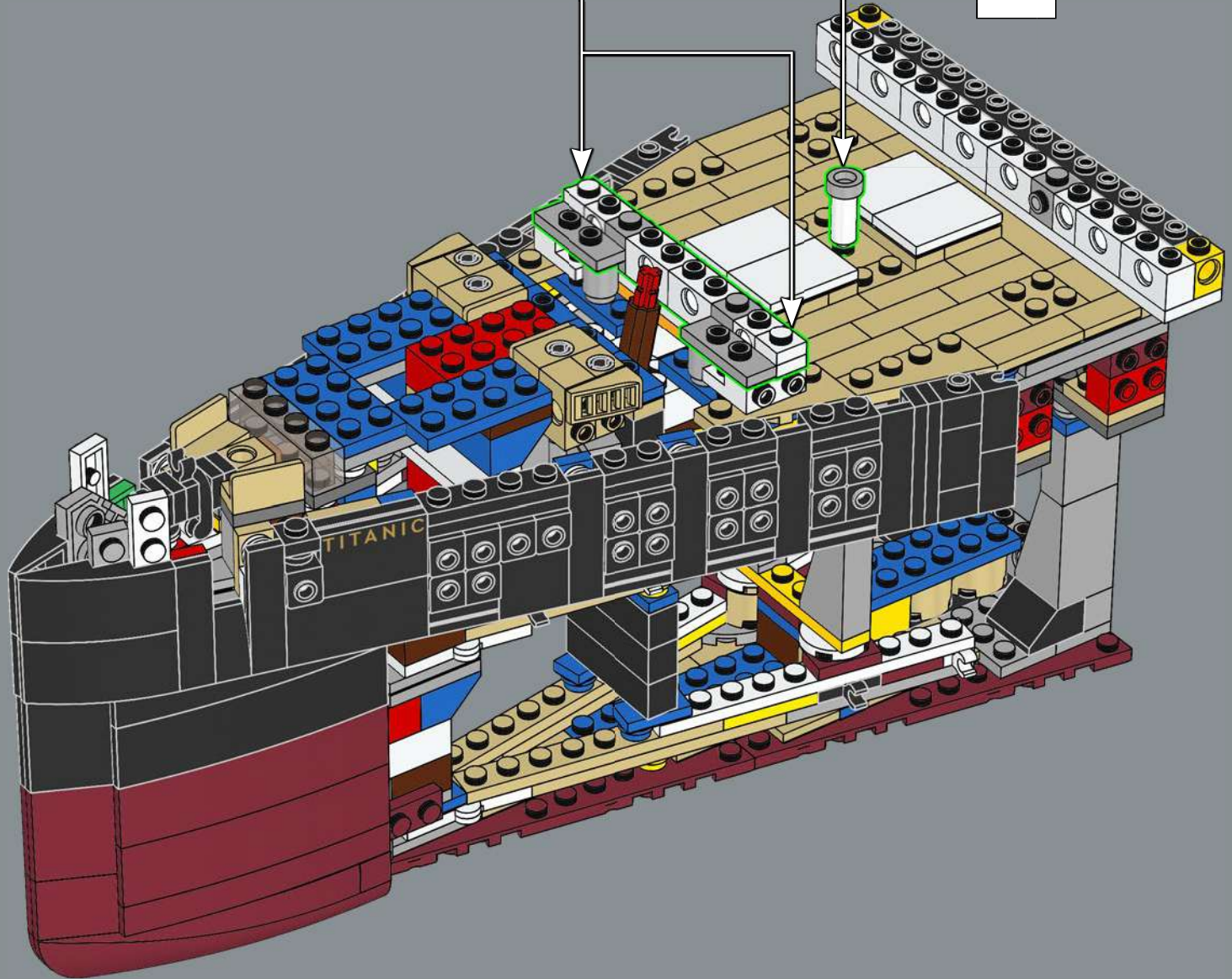
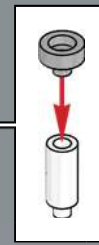
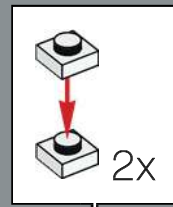

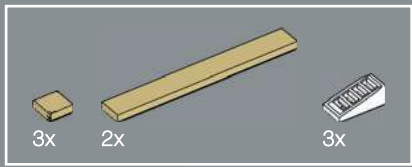

98

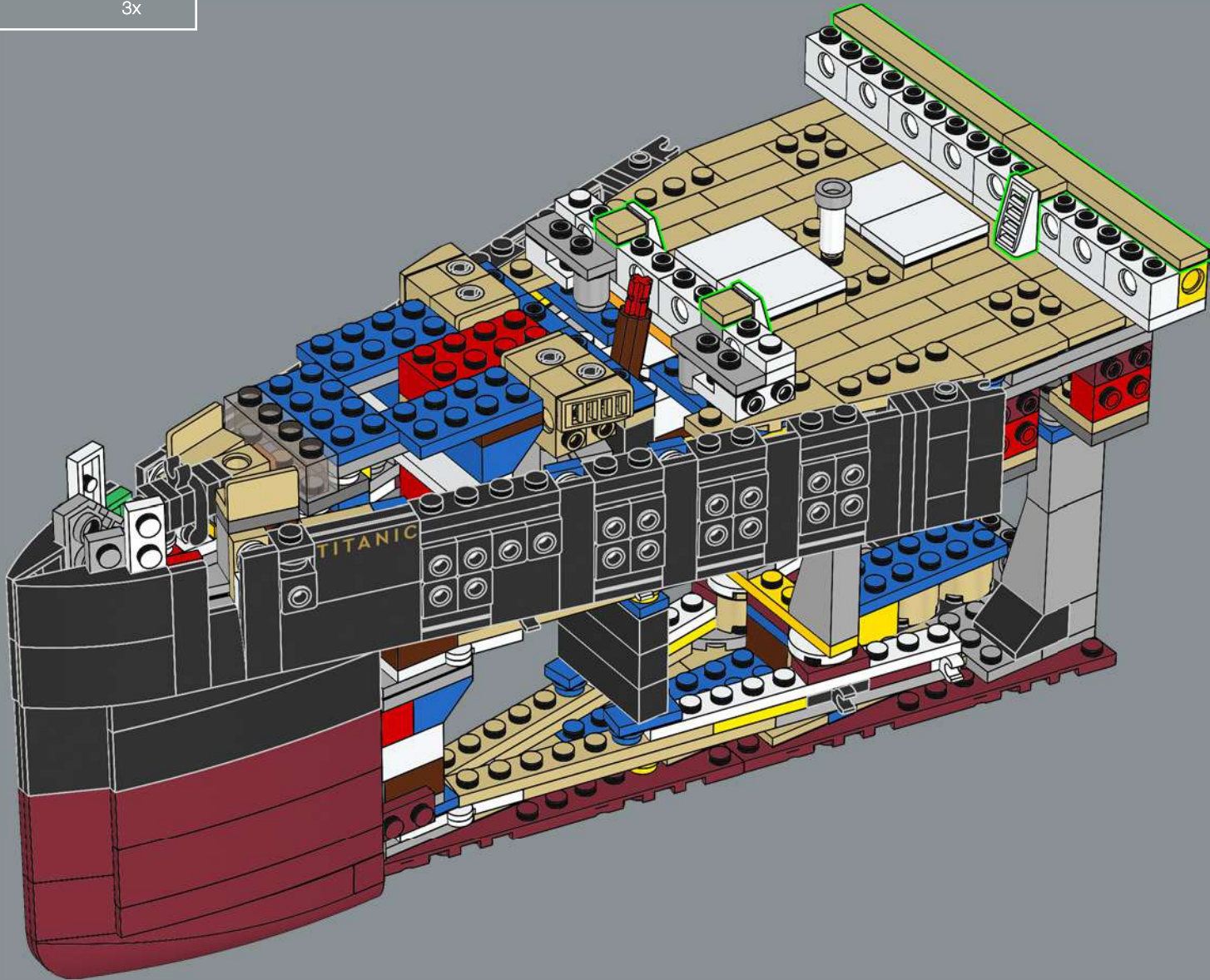

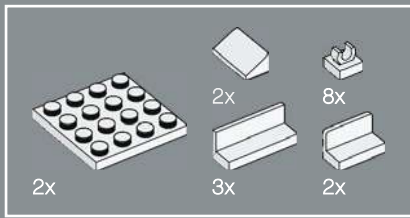

99

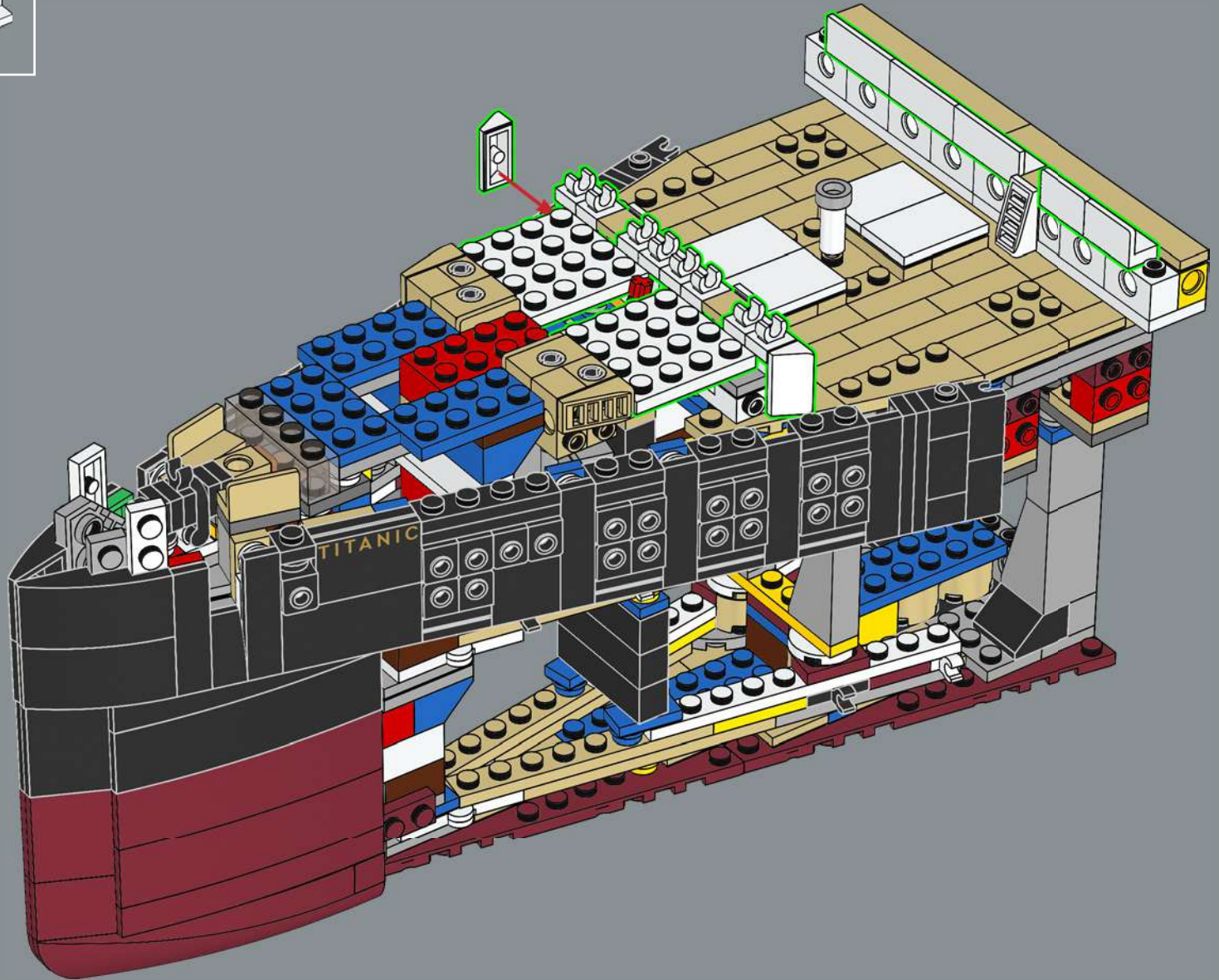

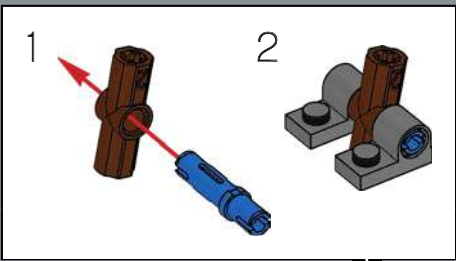
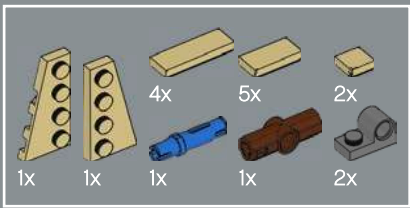

100

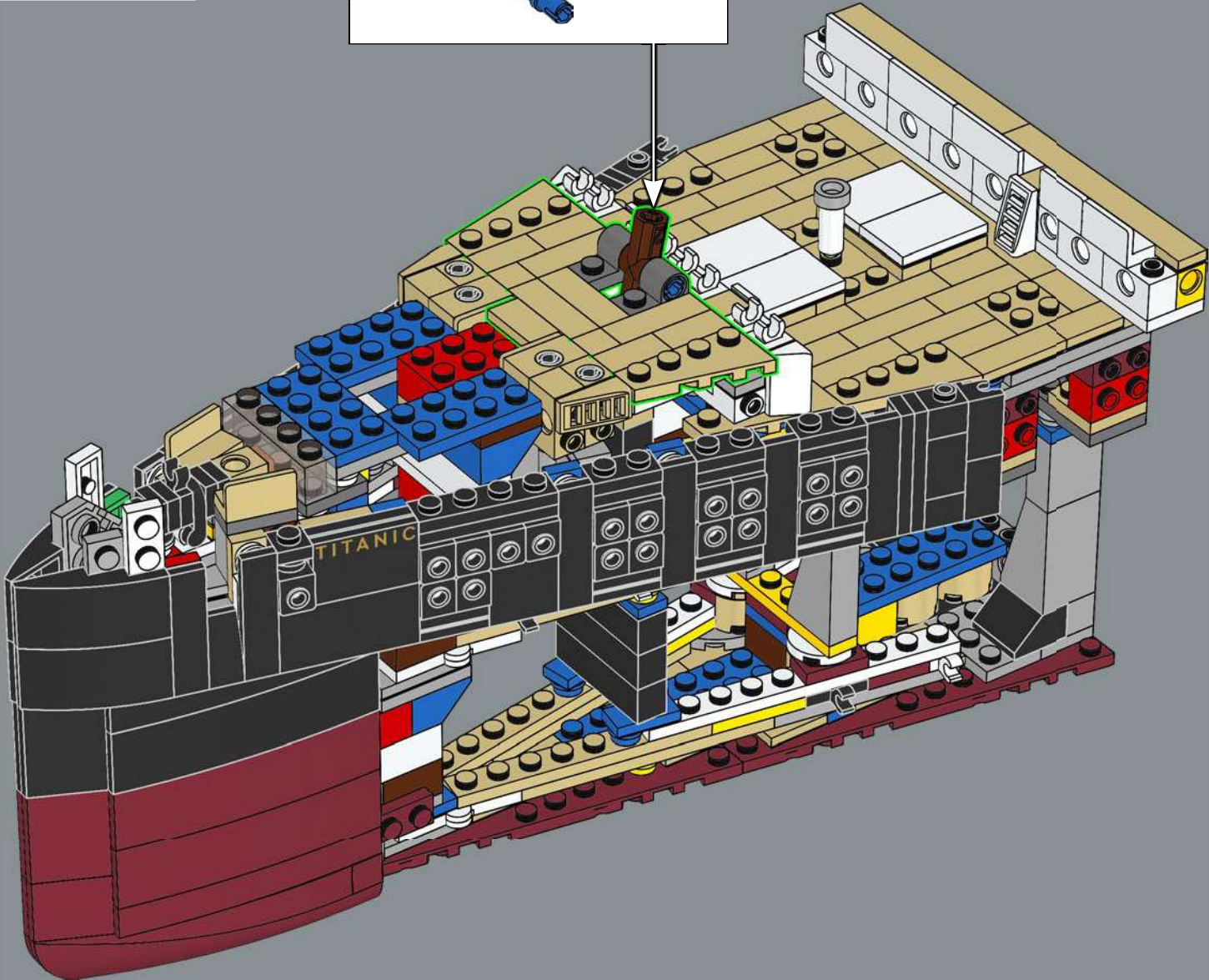

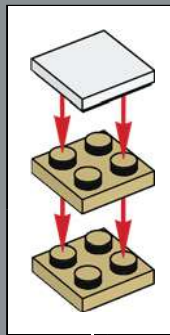
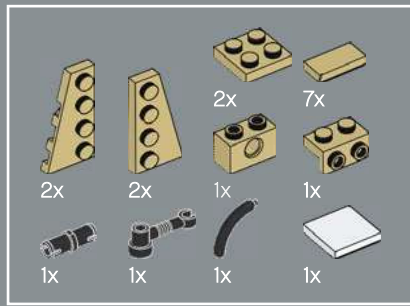

101

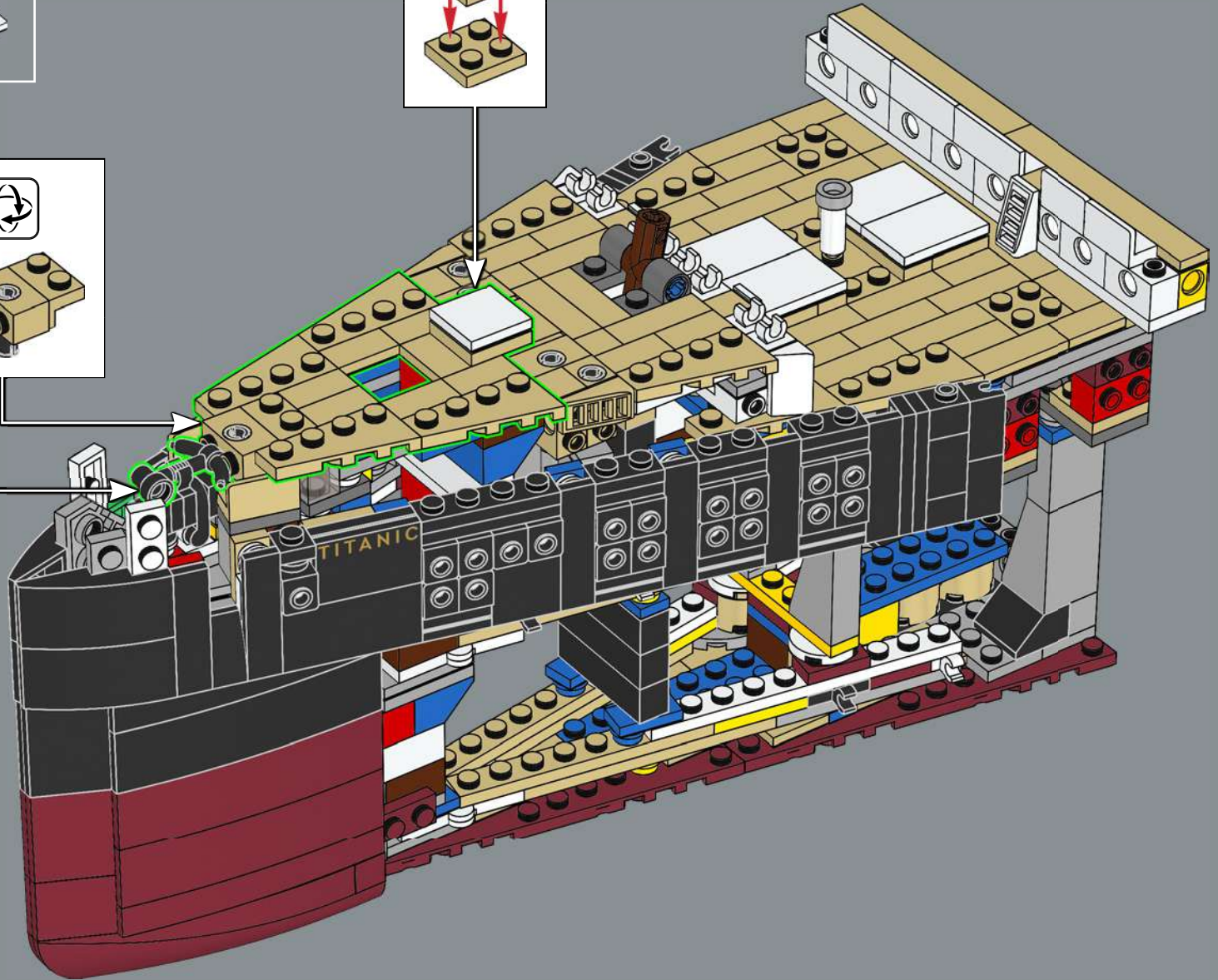
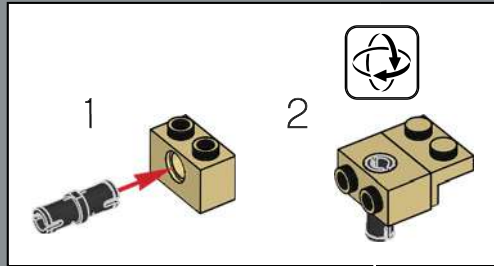

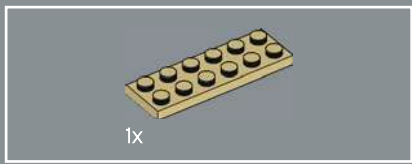

102

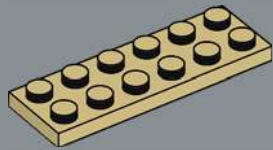

103

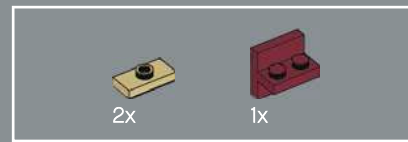
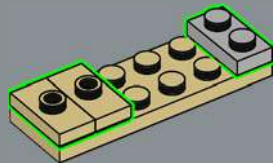

104

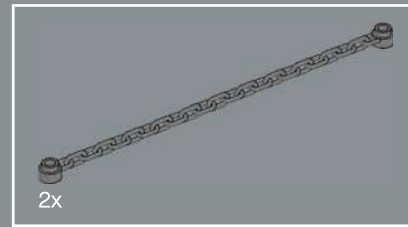
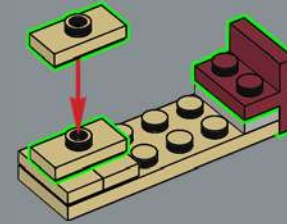

105

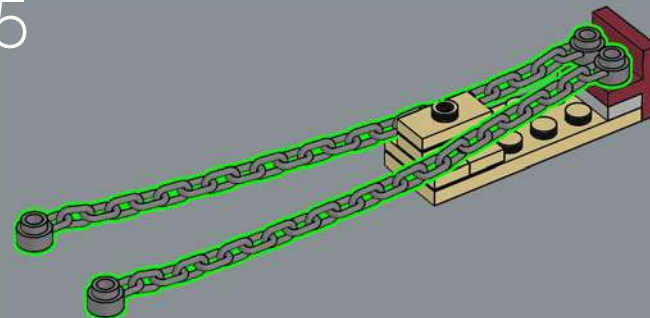

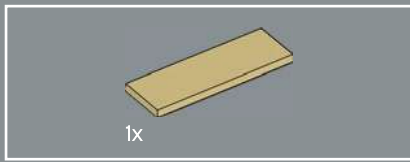

106

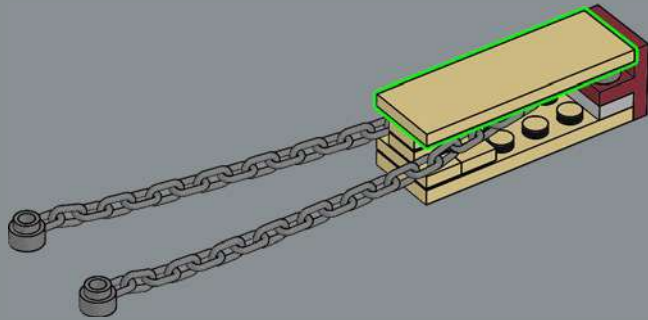

107

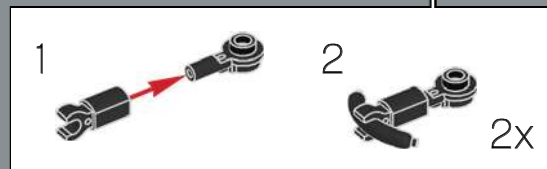
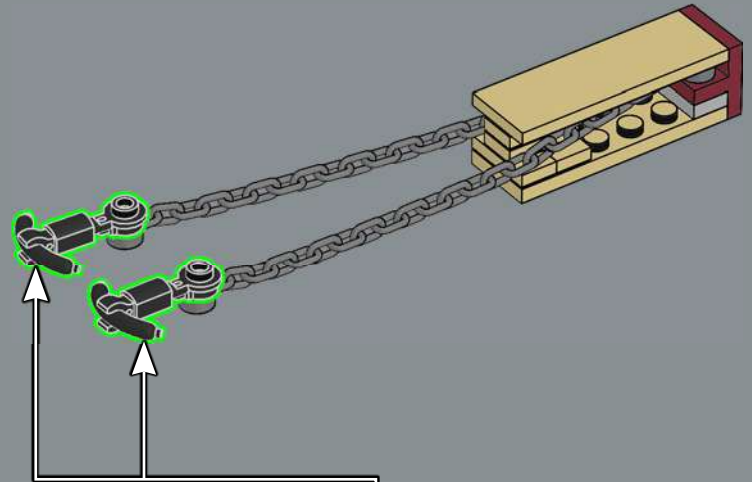

The *Titanic* was fitted with three anchors:
one on each side and the heaviest in the centre.

108

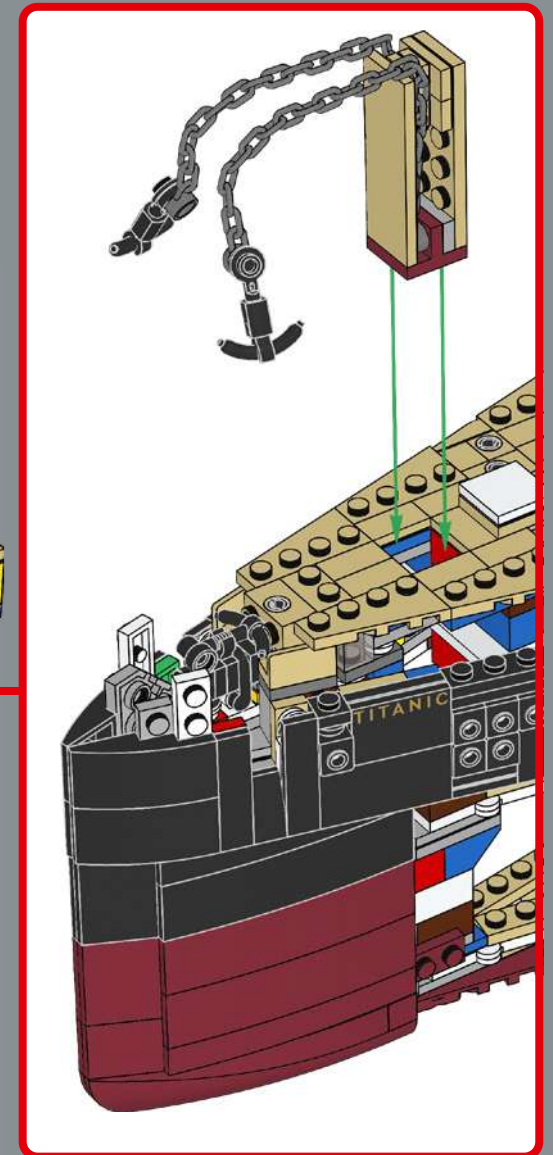
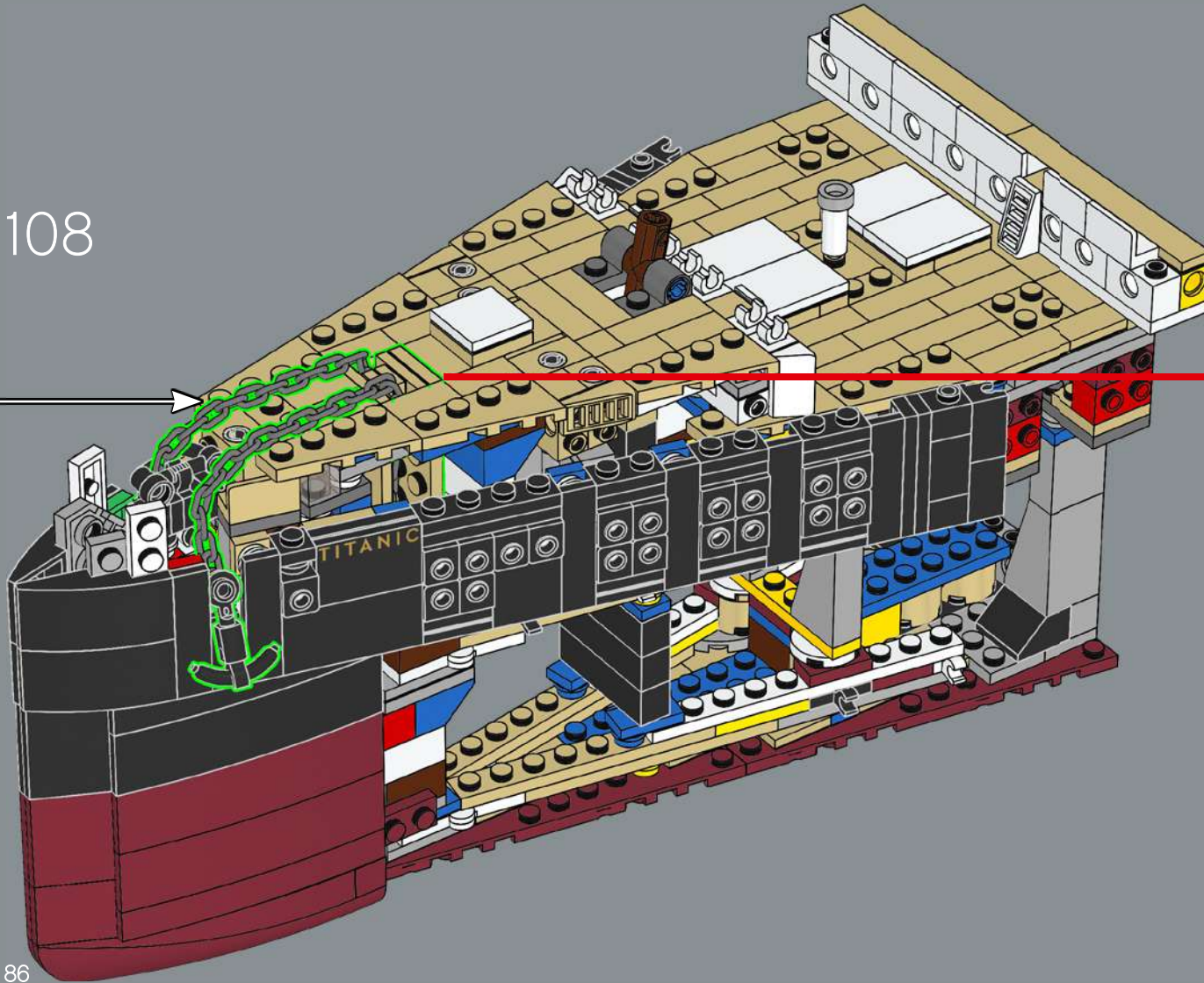

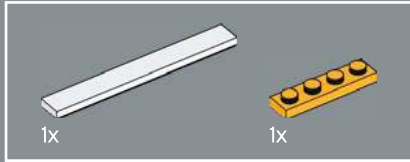
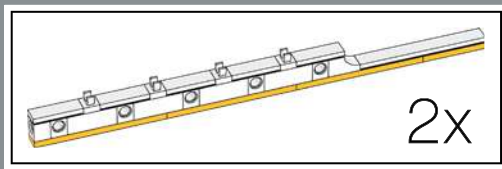

109

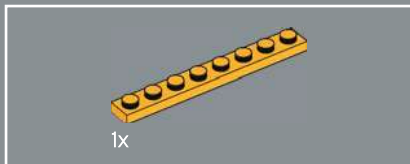
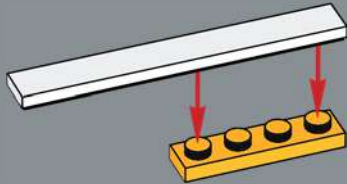

110

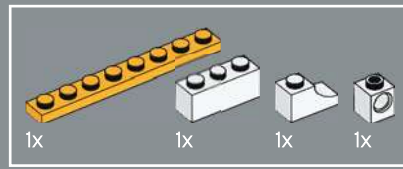
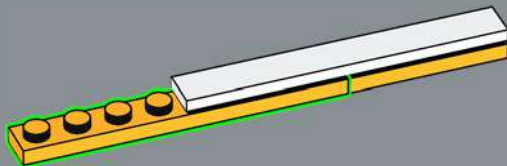

111

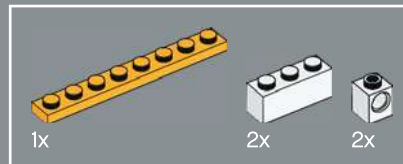
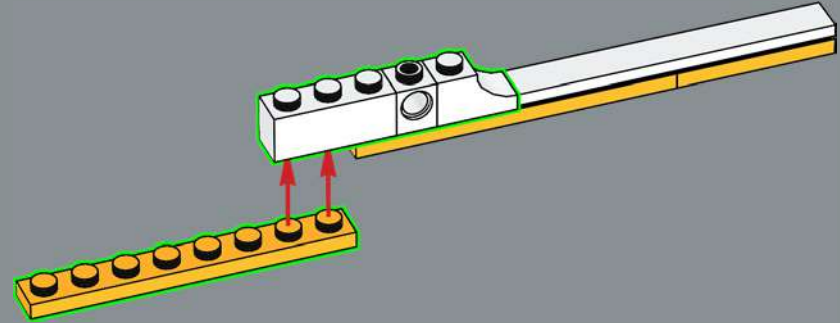

112

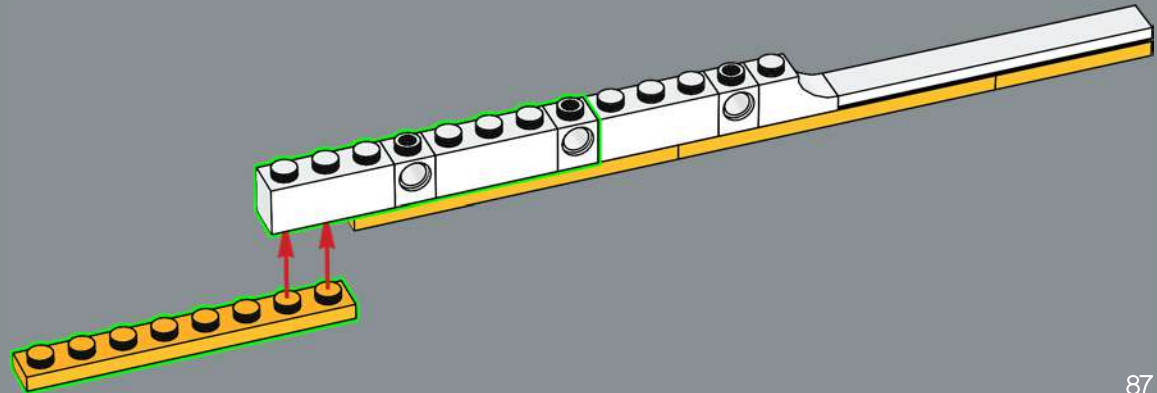

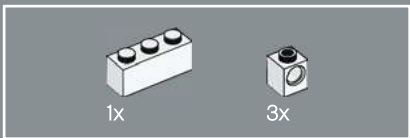

113

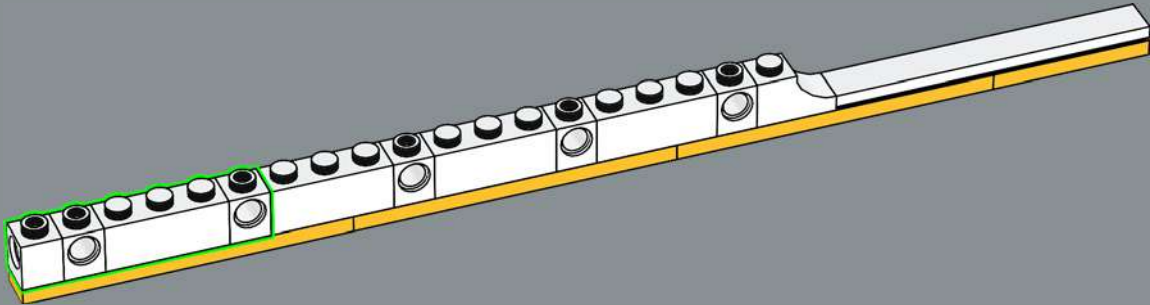

114

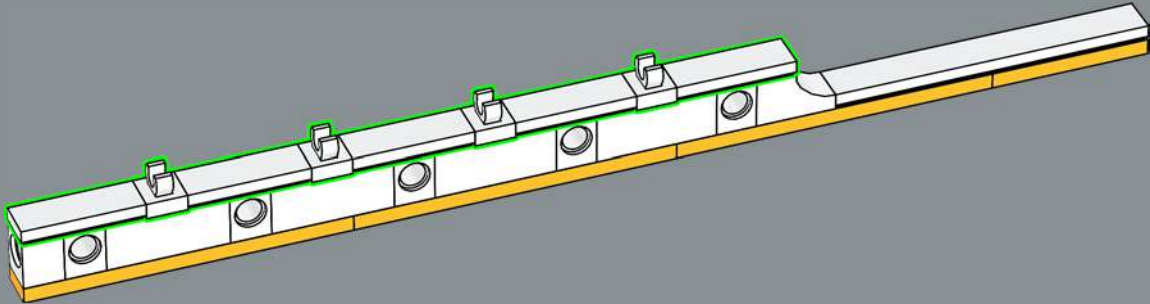

2x

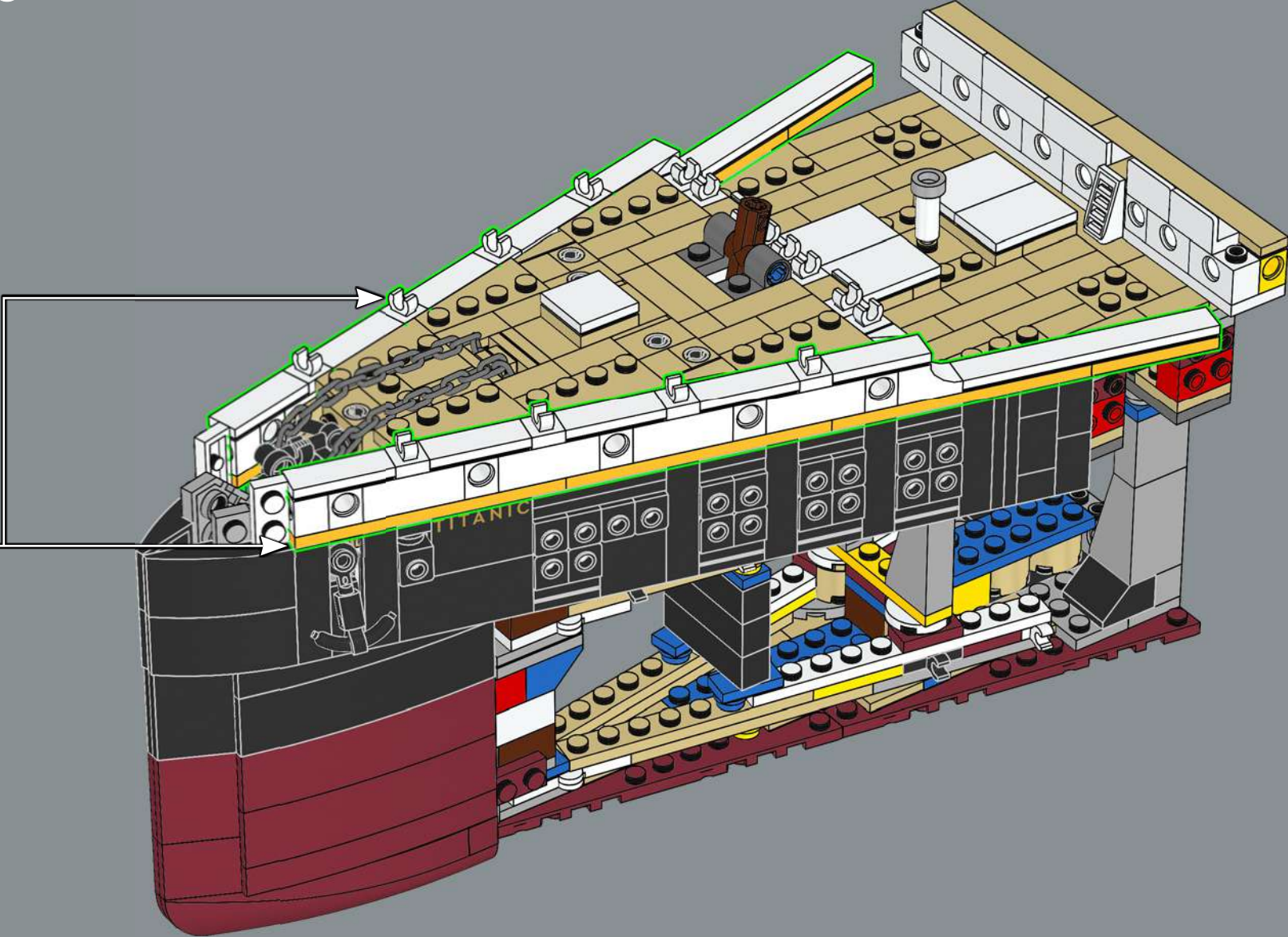

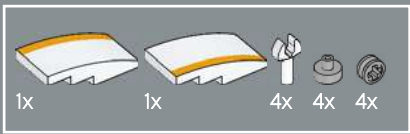

116

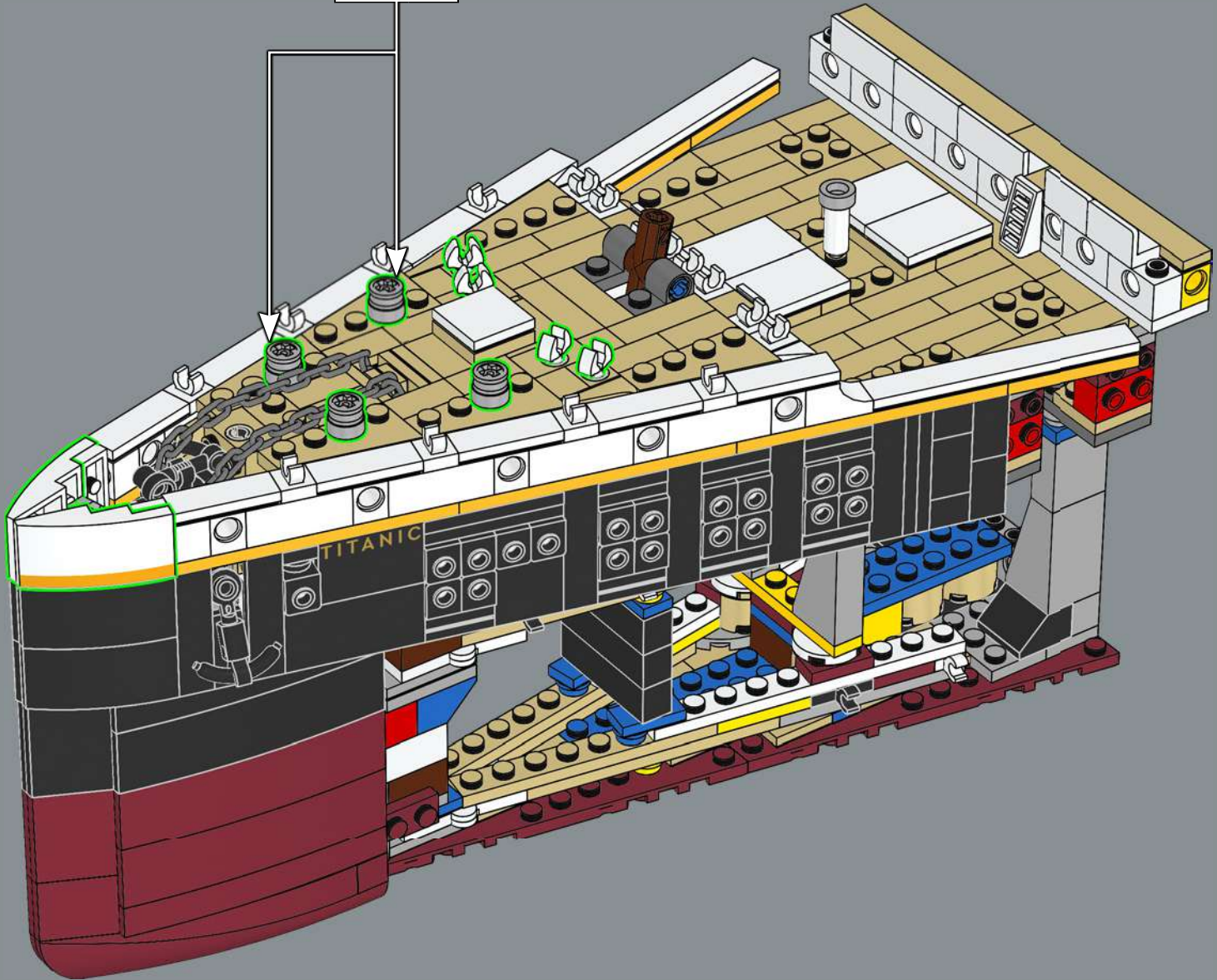
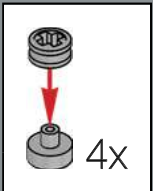

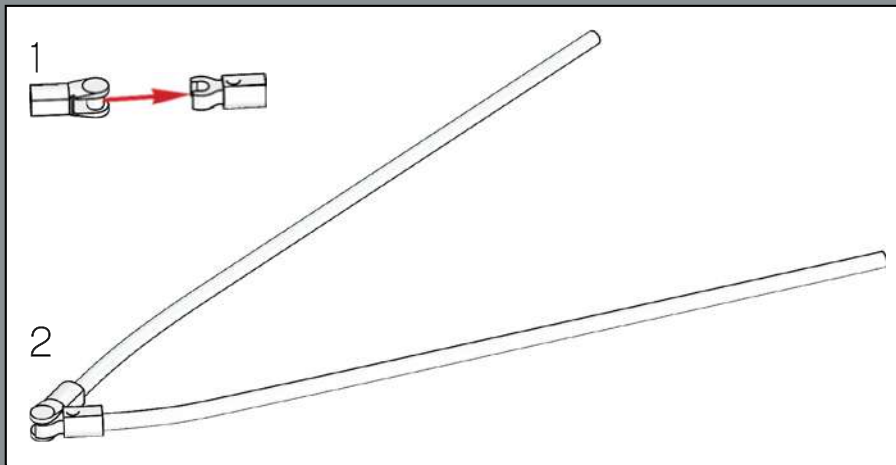
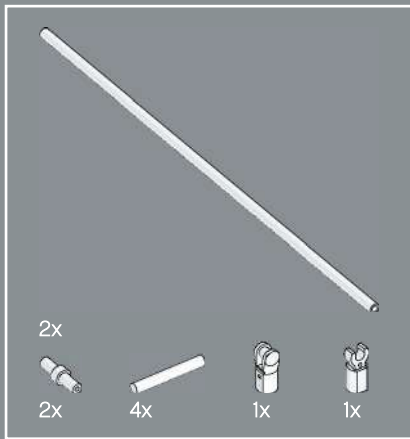

117

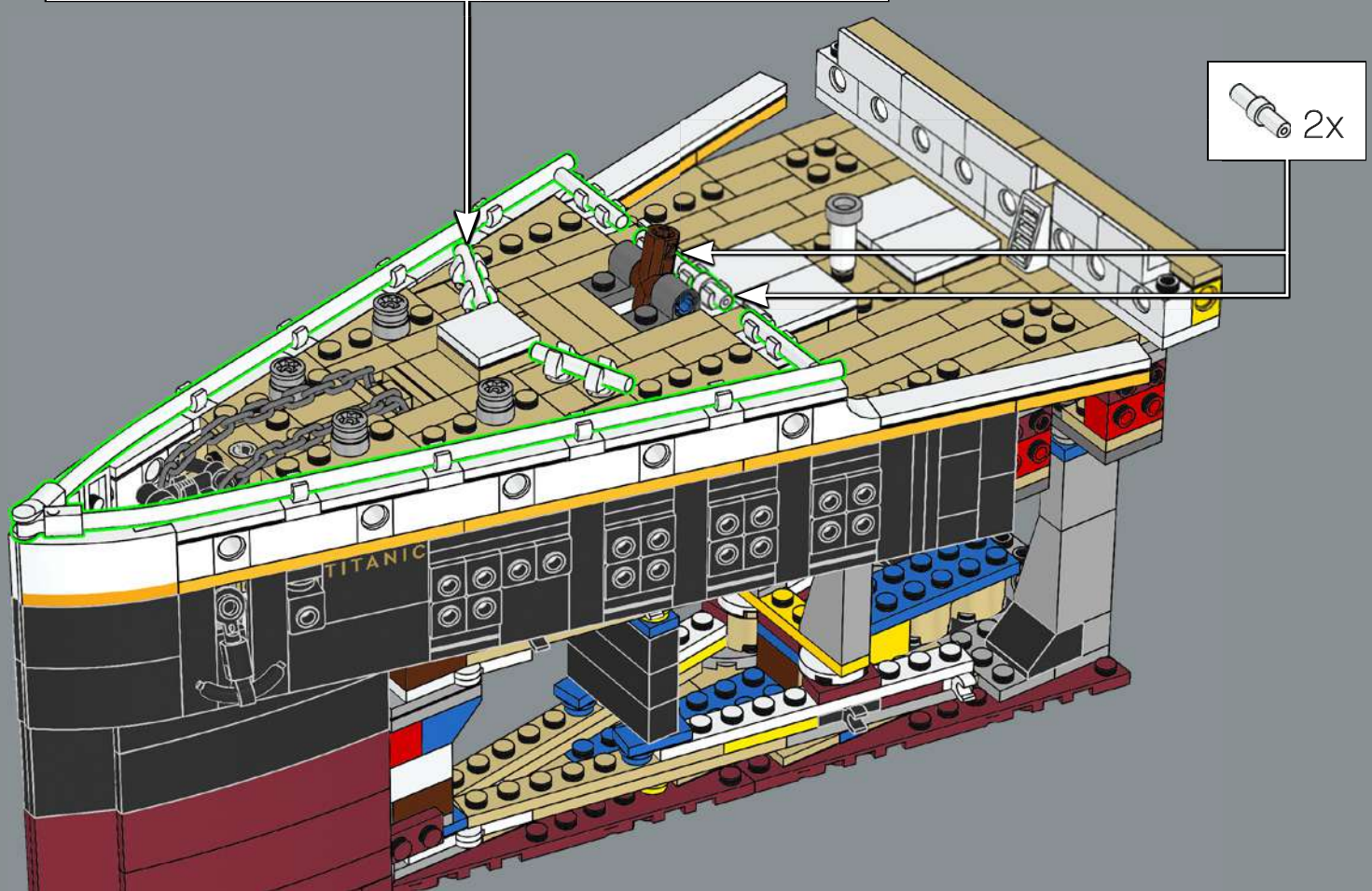
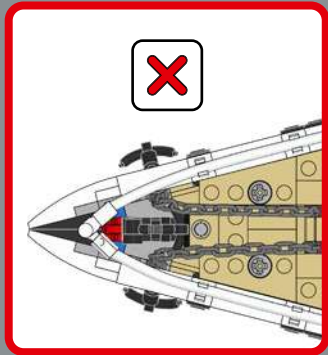
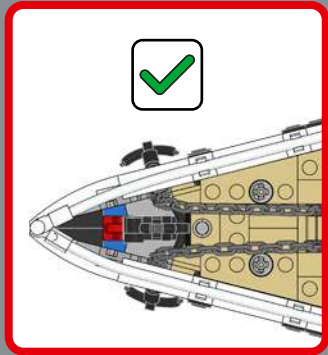



118

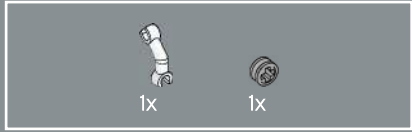

119

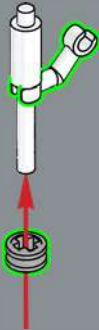

120

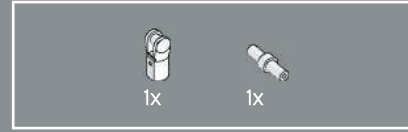
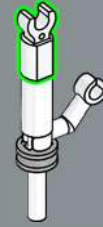

121

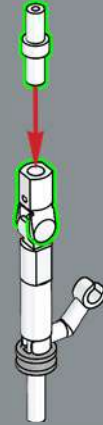



122

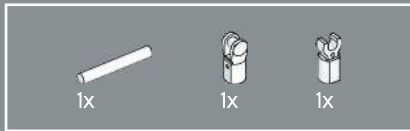
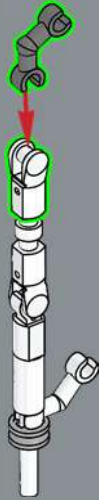

123

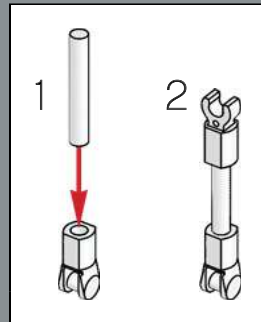
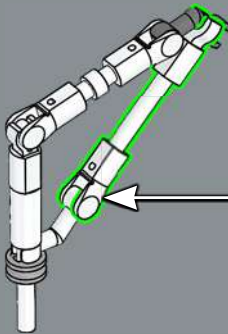

124

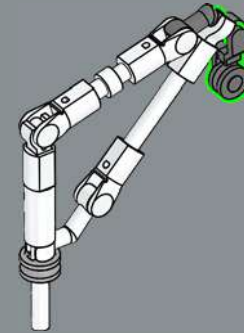

125

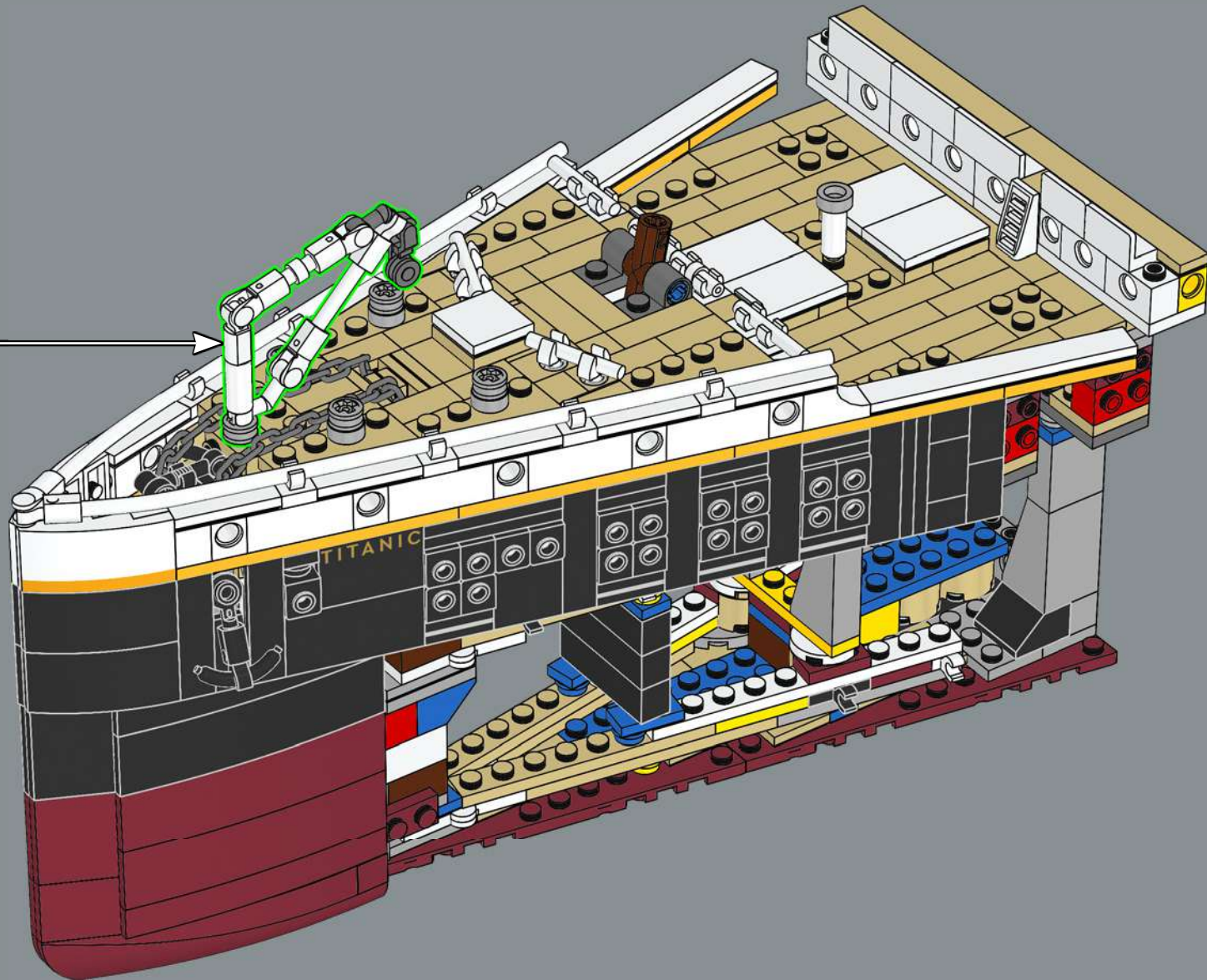

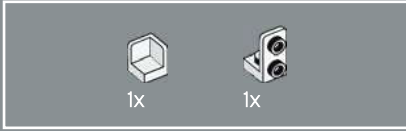
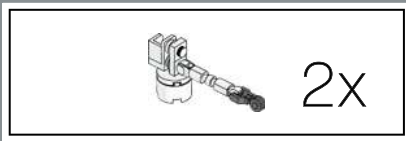

126

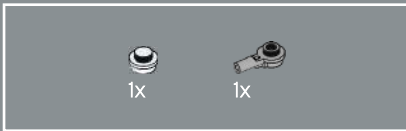

127

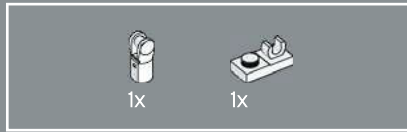
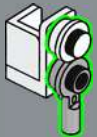

128

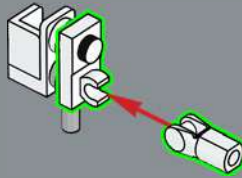

129

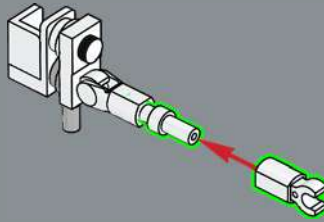

130

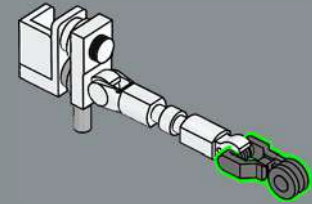

131

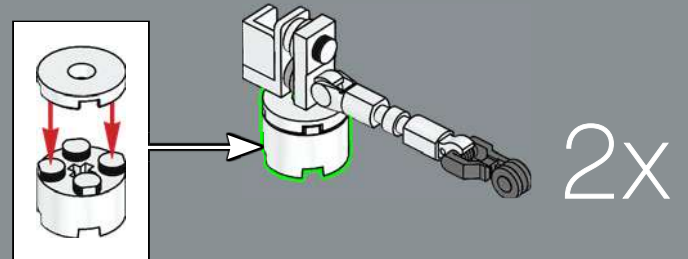

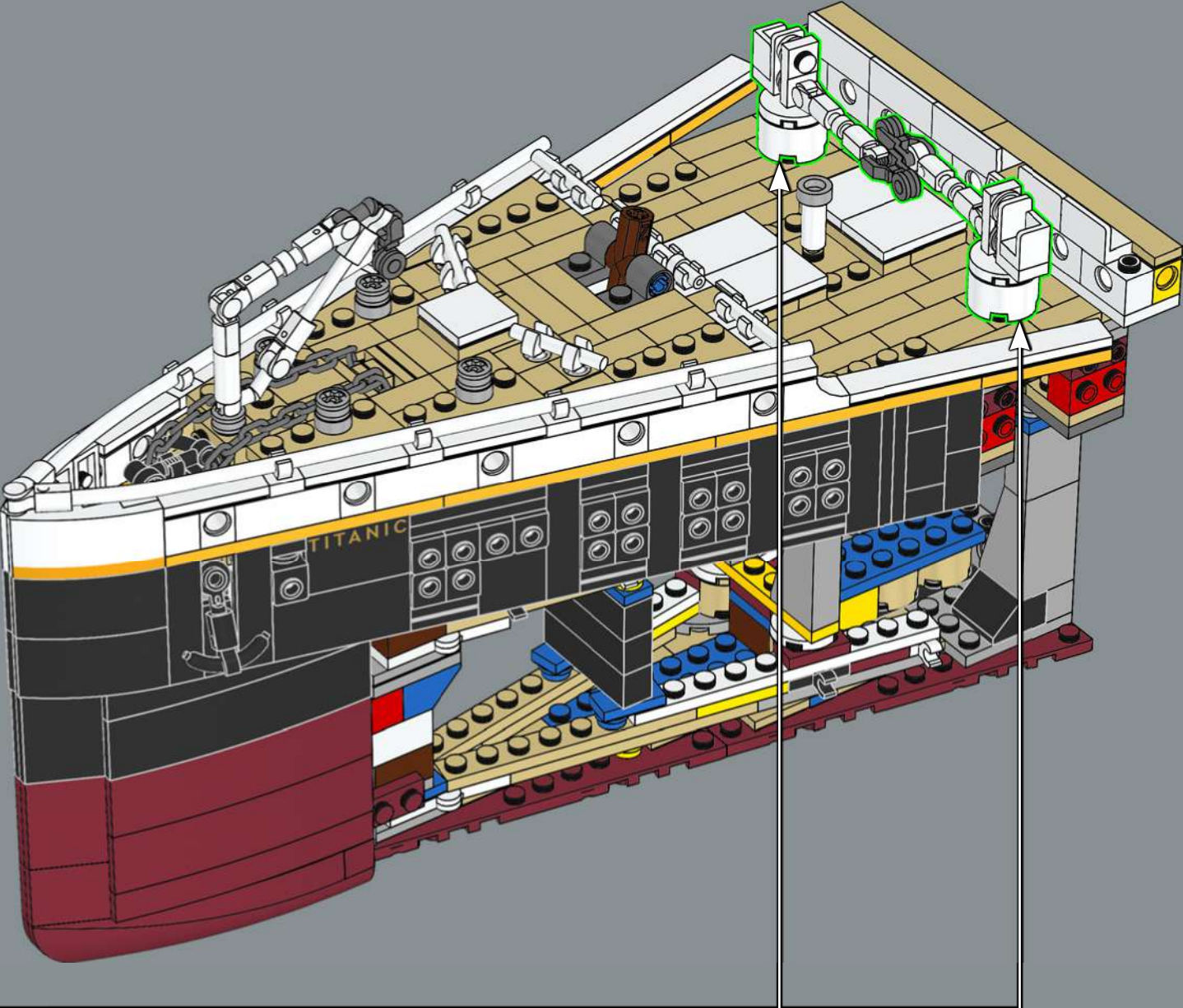

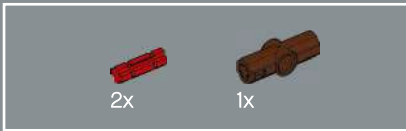

133



134



135

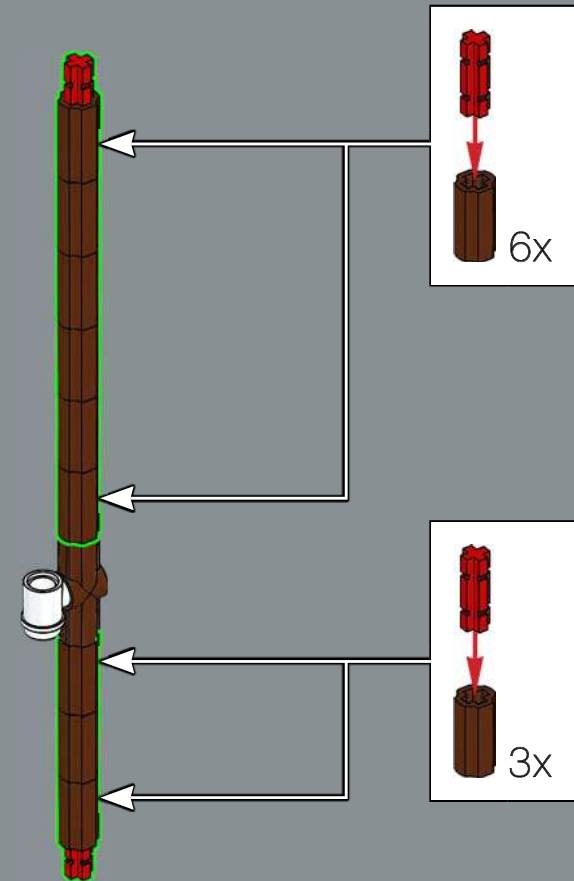

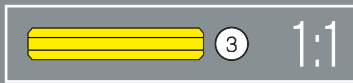
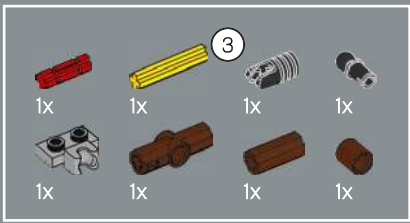

136

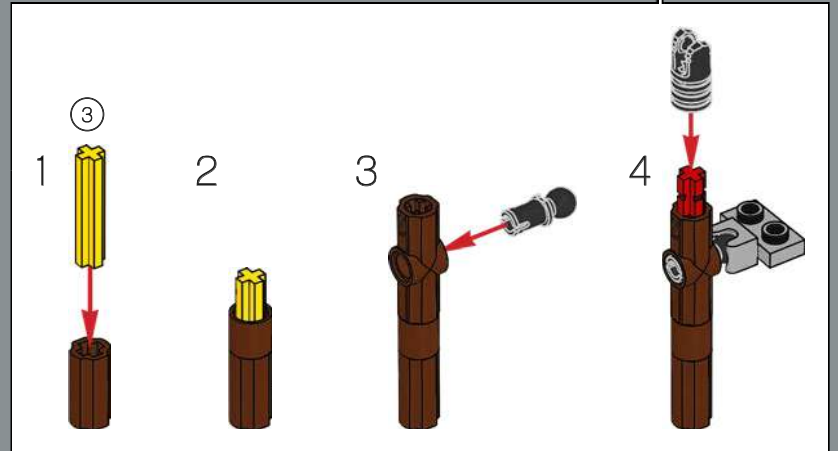

137

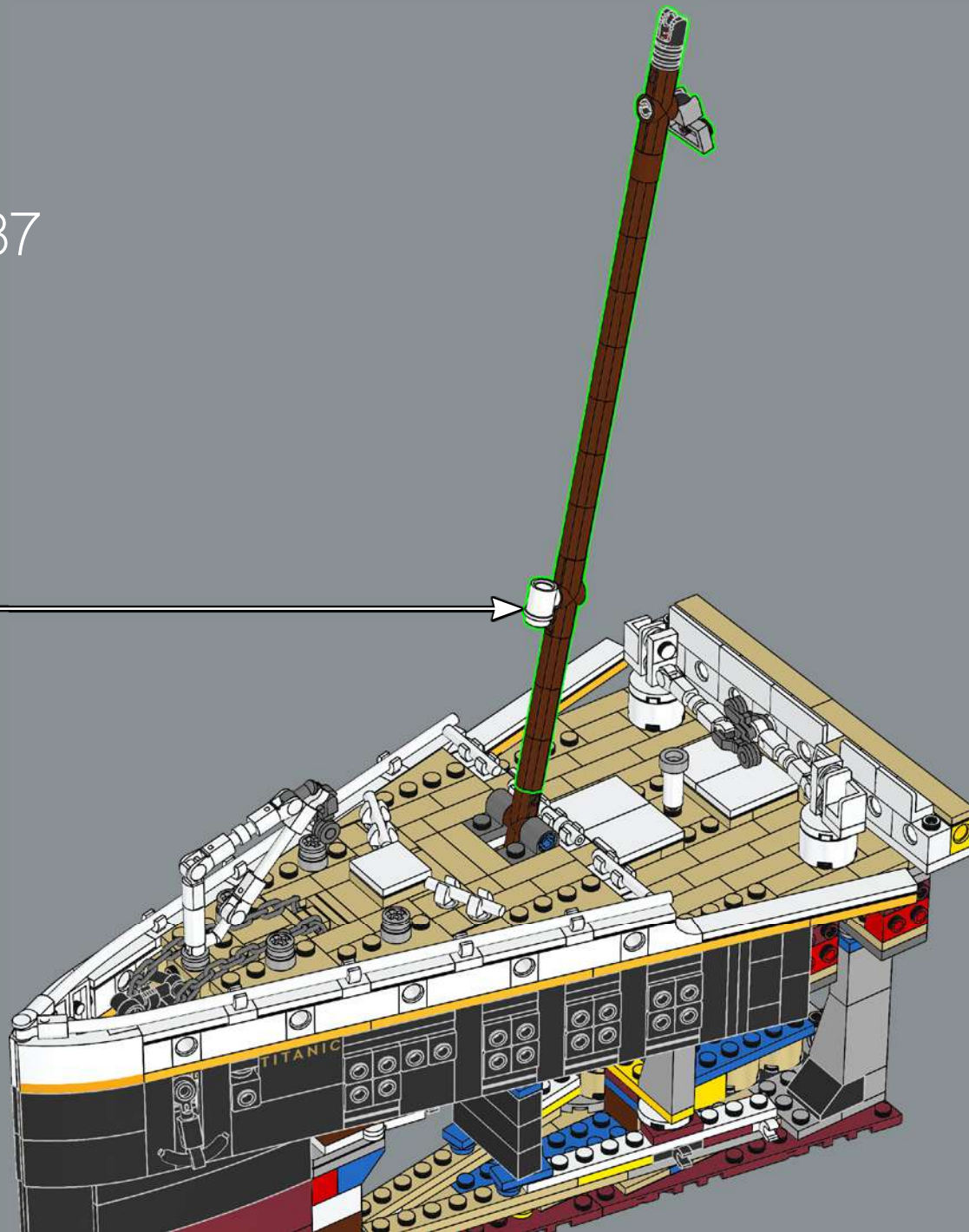

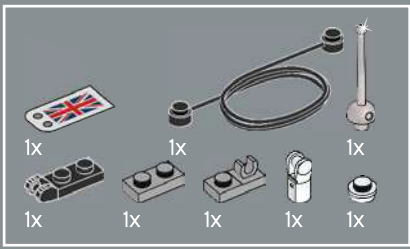

138

1

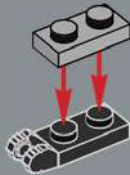

2

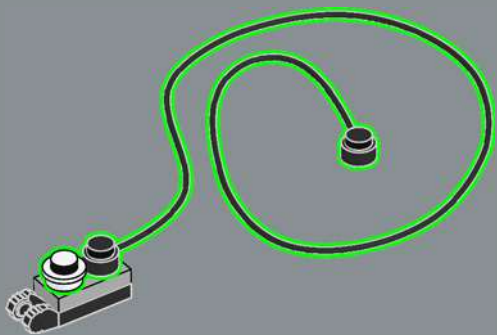

3

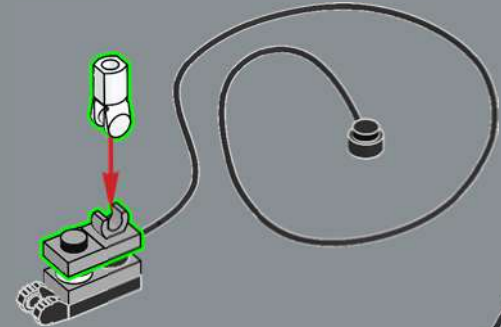

4

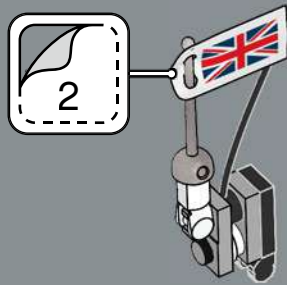

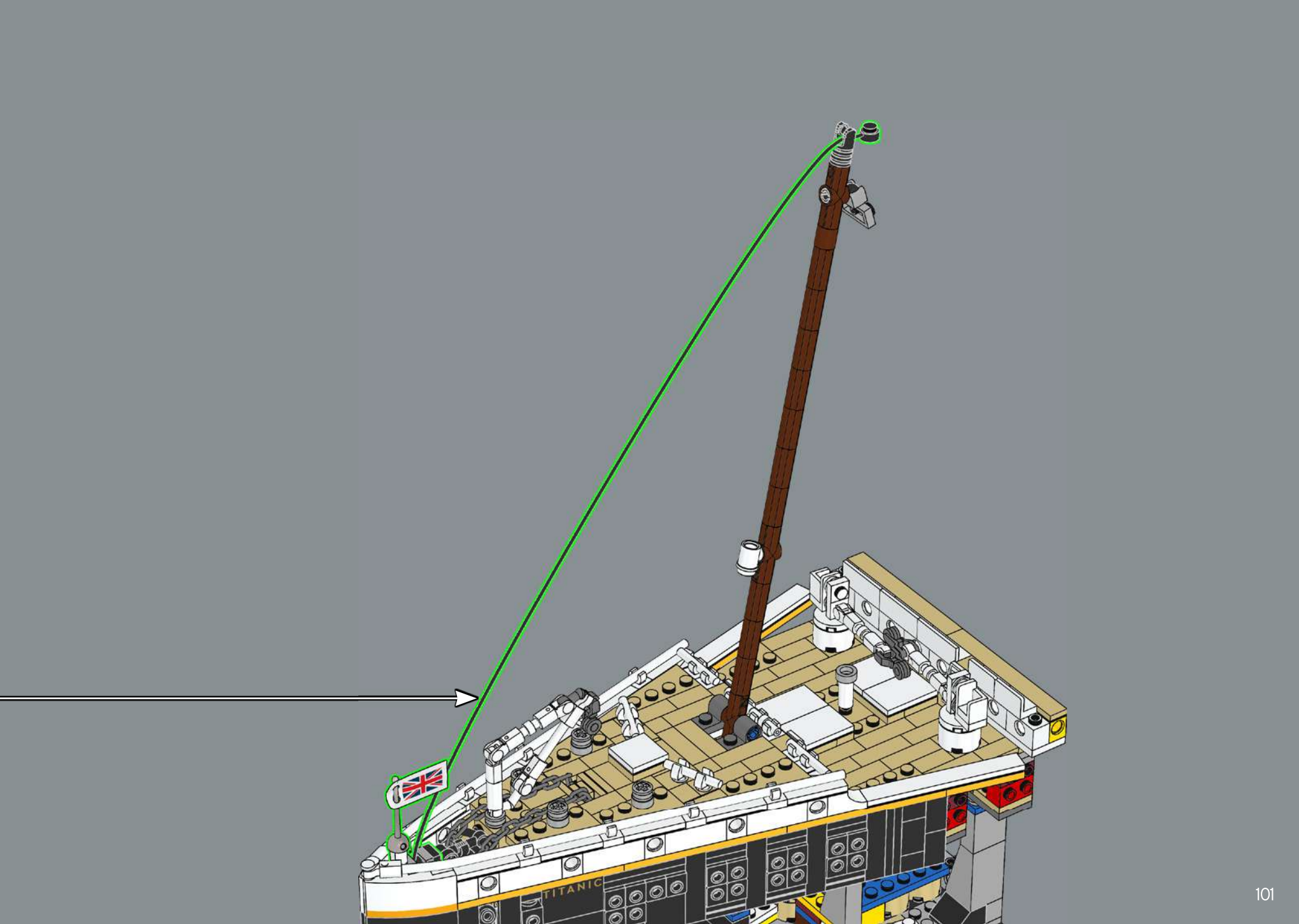

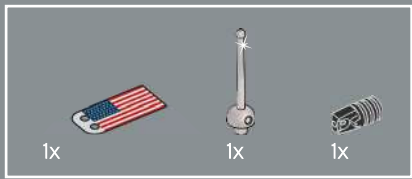

139

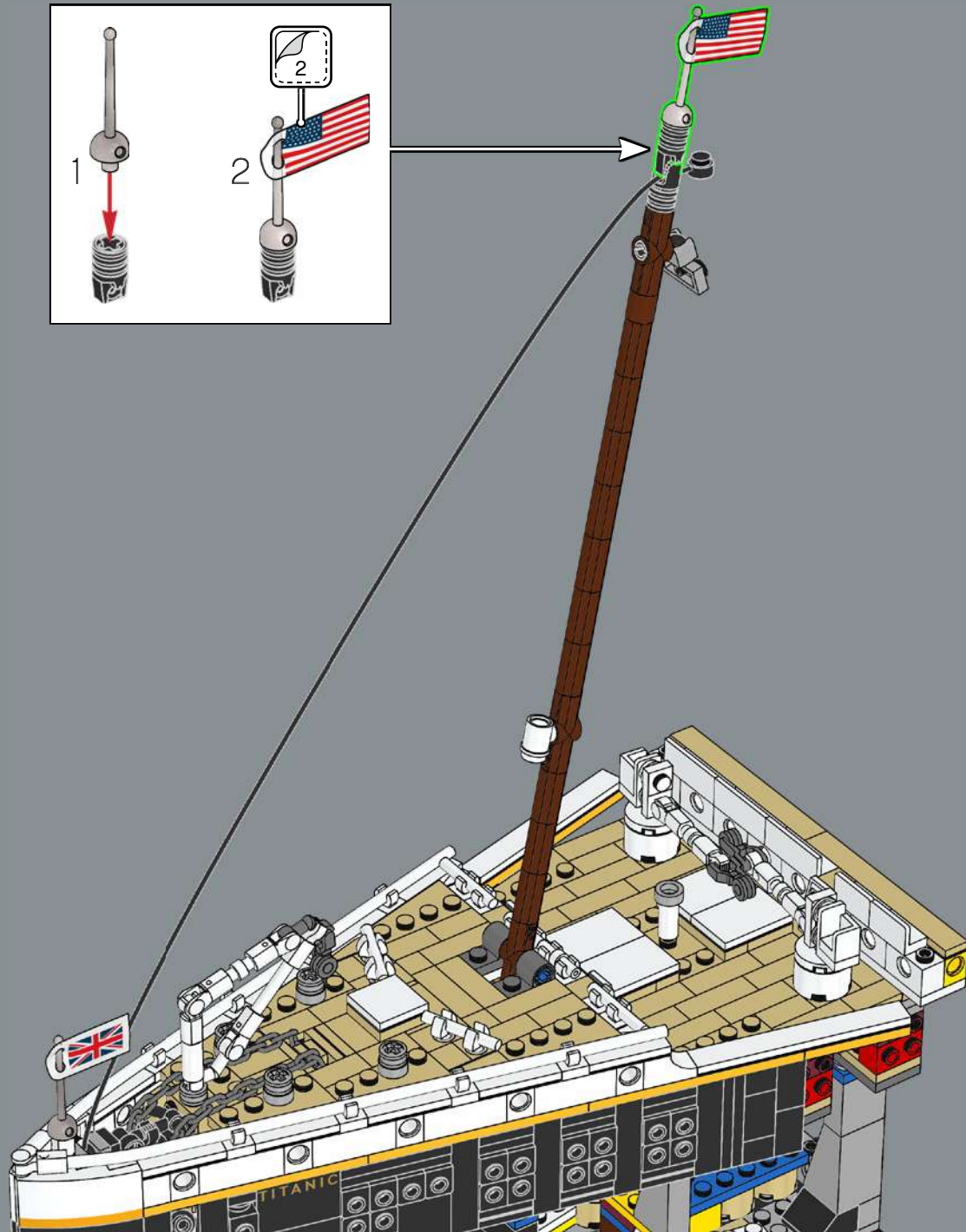
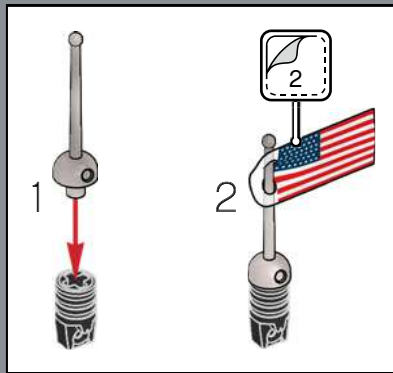

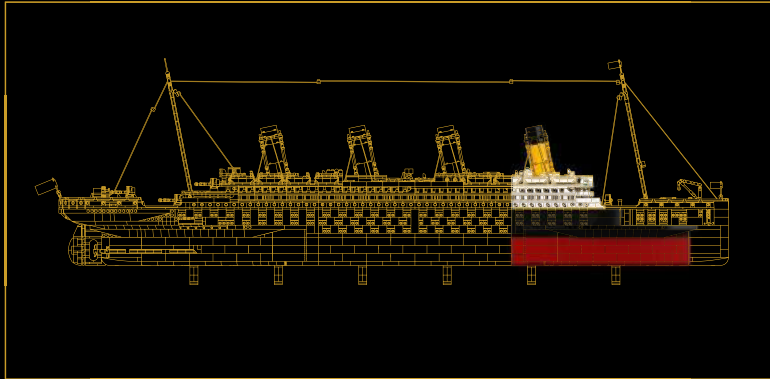

SECTION 2:

BRIDGE & FUNNEL

In this second section, the hull reaches its maximum width, 18 modules or roughly 144 mm (5.6 in.). Inside the hull, you will begin construction of the ship's cross section, including part of the swimming pool, the grand staircase and one of *Titanic's* boiler rooms. You will also build the iconic bridge house and the first of four funnels.

↓ A hidden locking mechanism inside the grand staircase allows the entire ship to connect securely together.



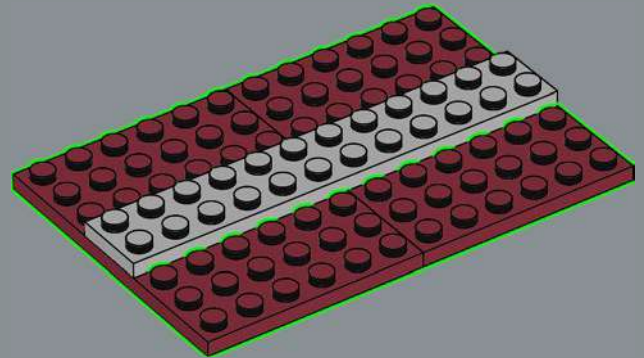
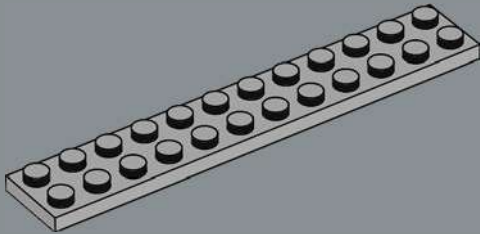
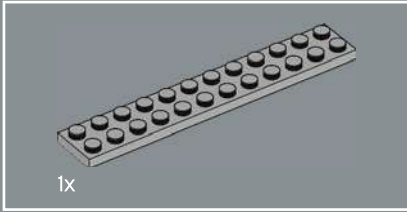
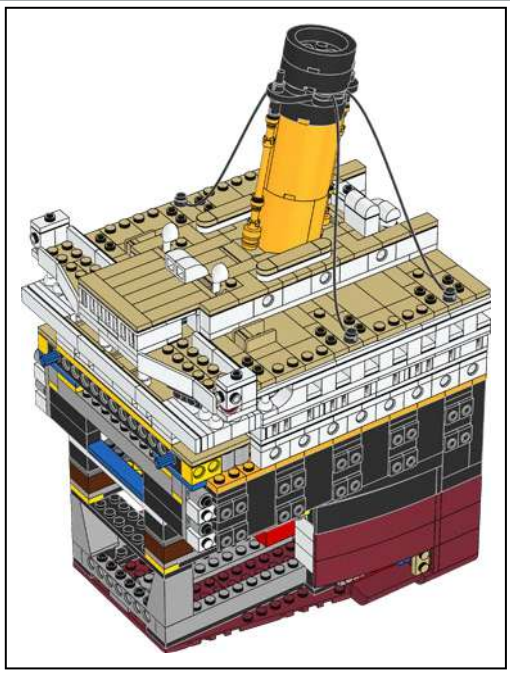
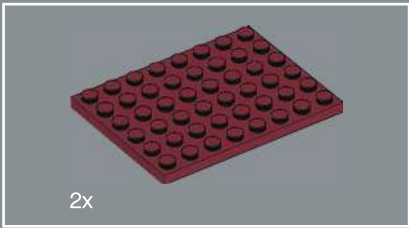
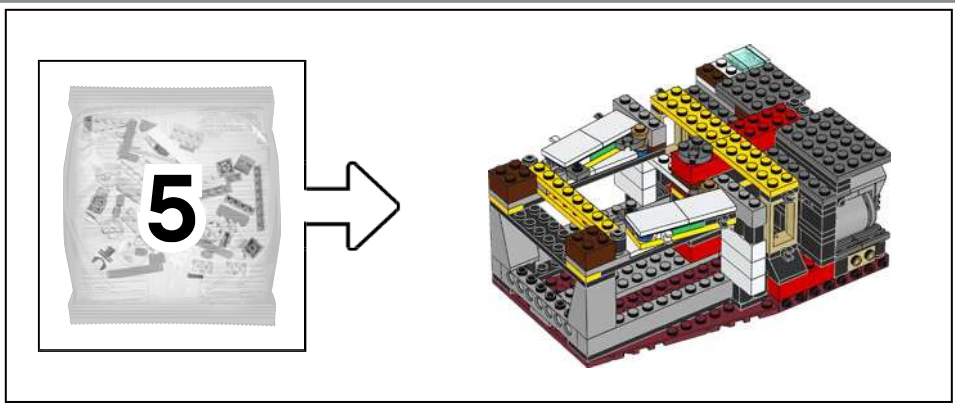

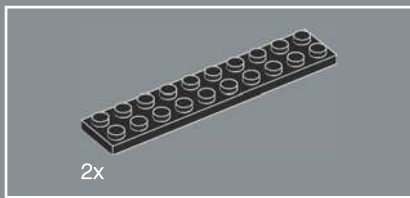

142

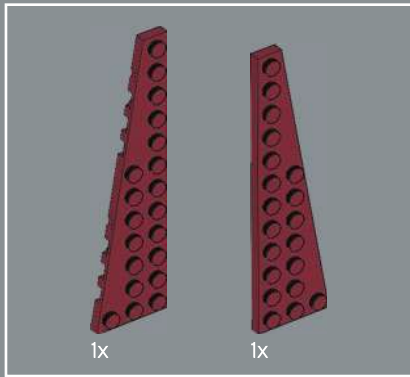
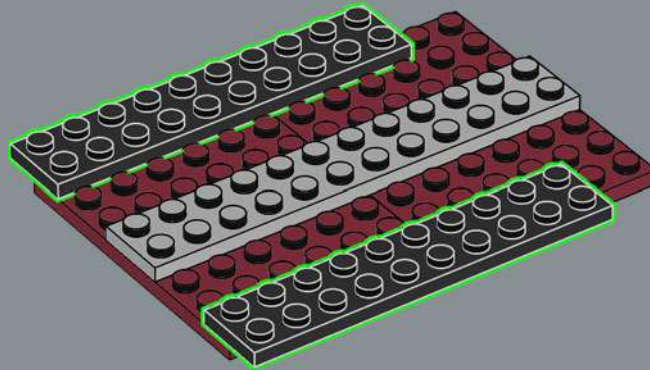

143

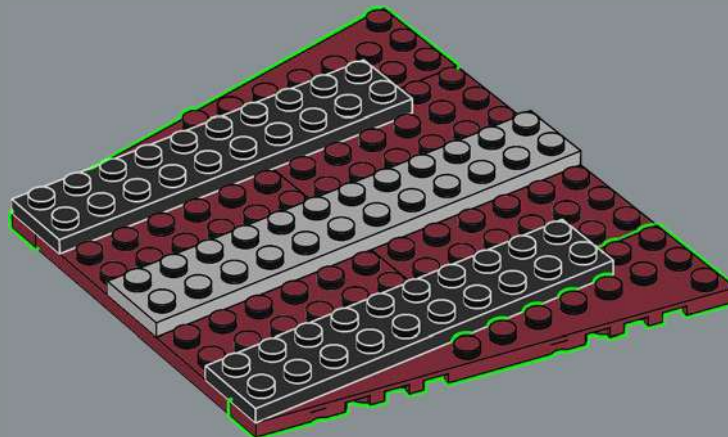

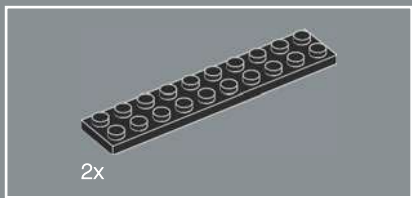

144

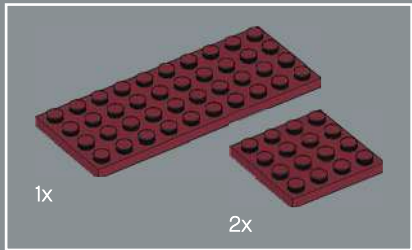
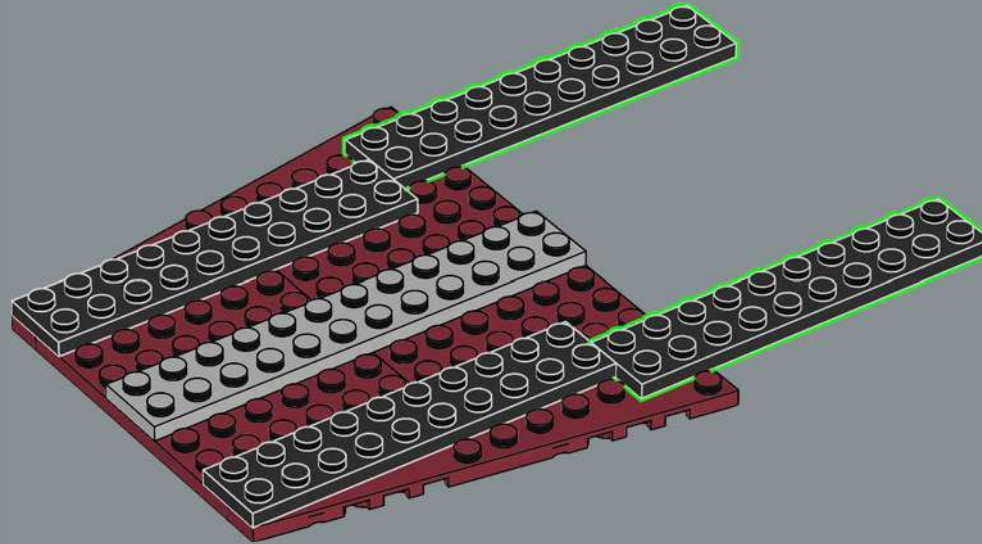

145

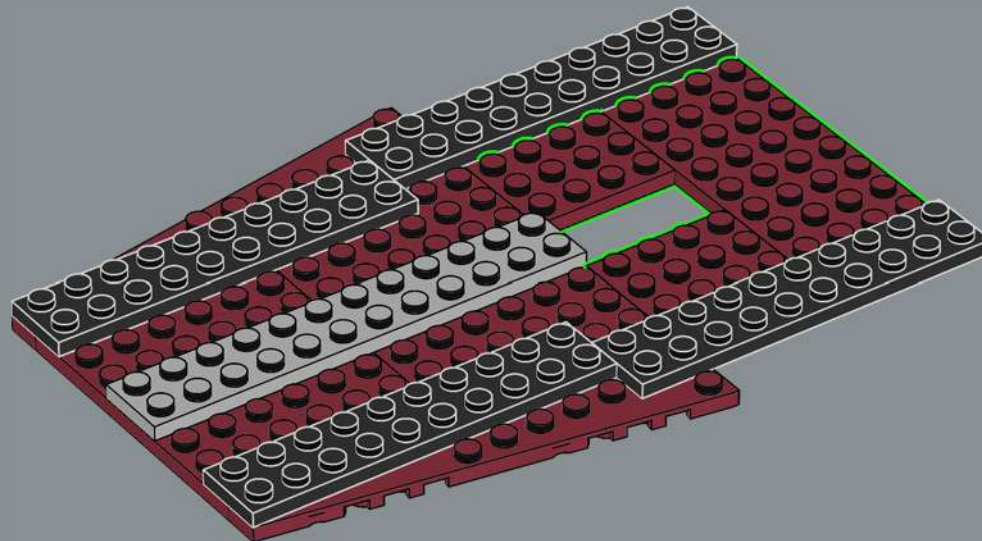

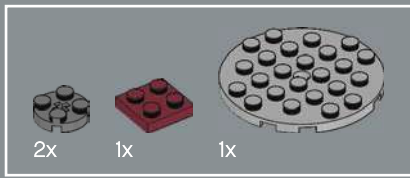

146

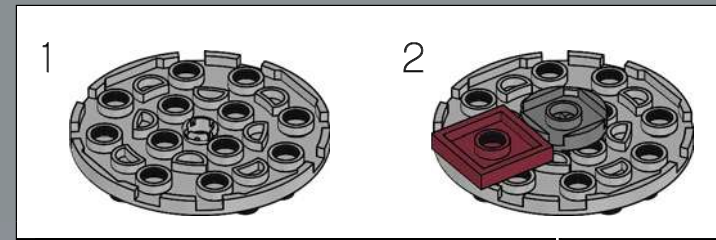
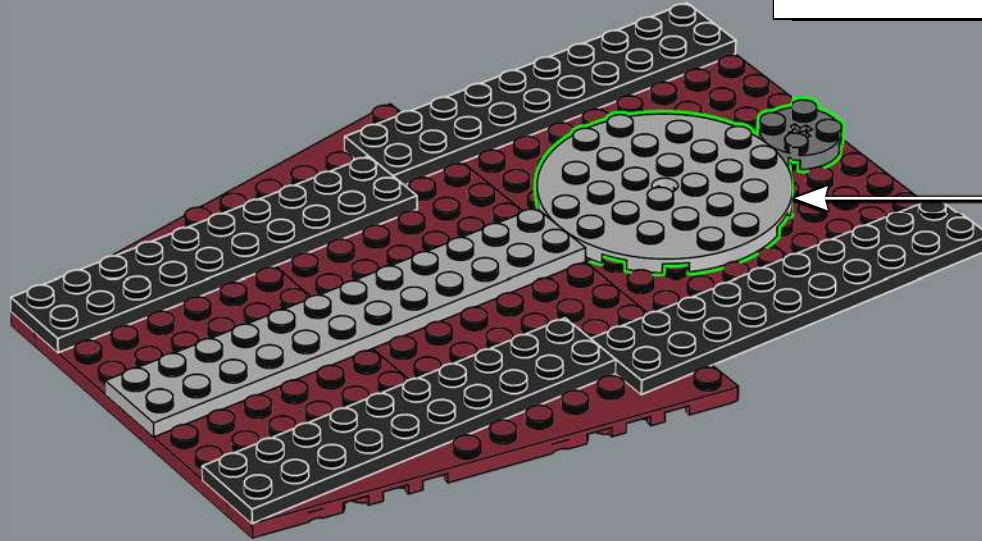

147

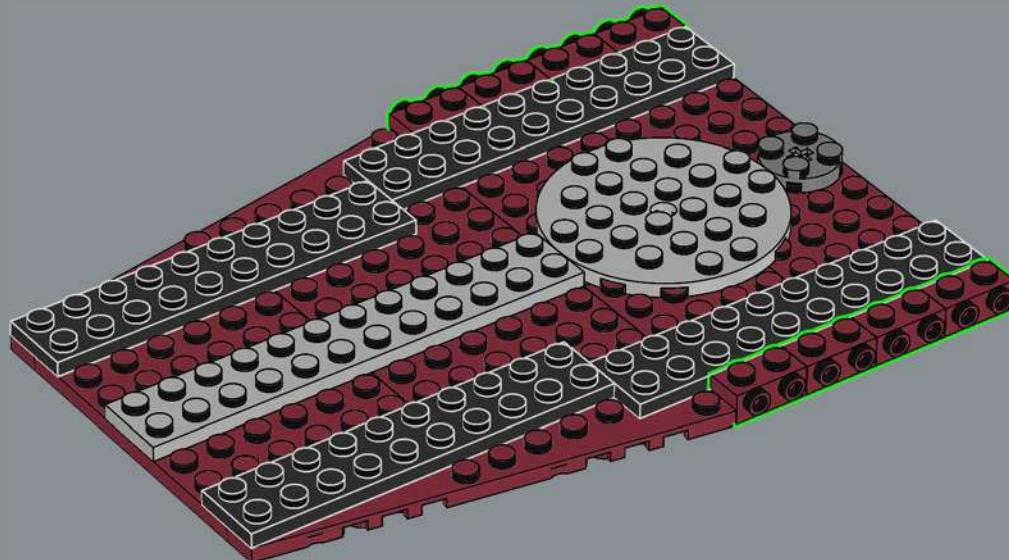

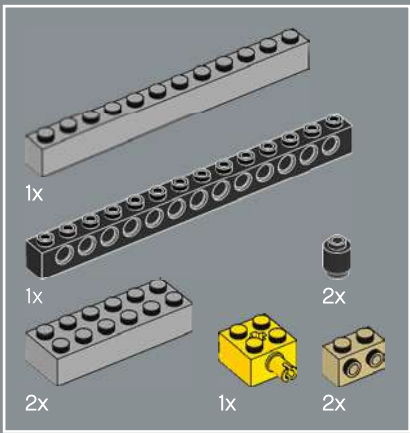

148

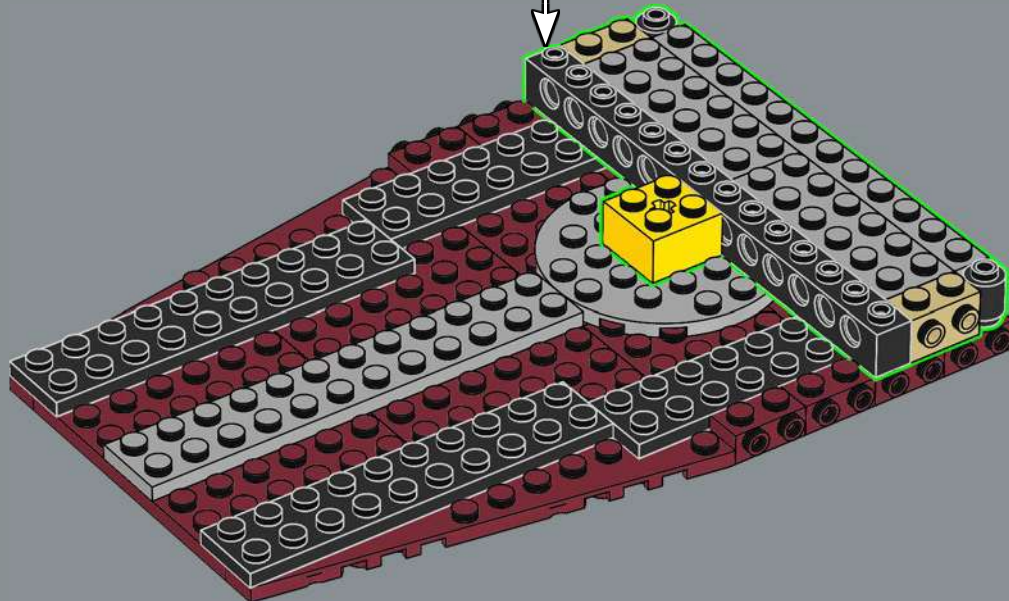
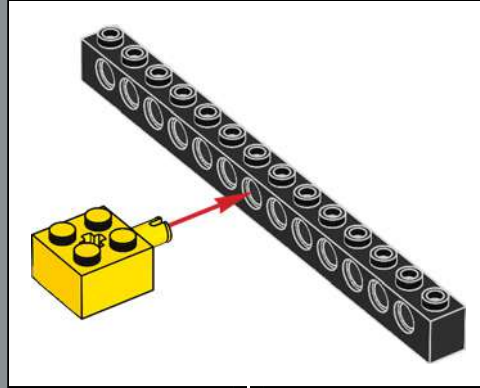

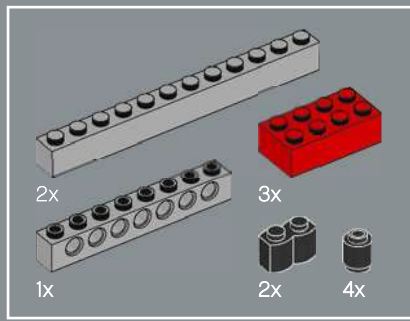

149

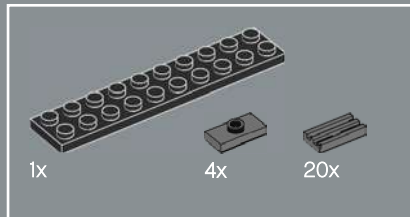
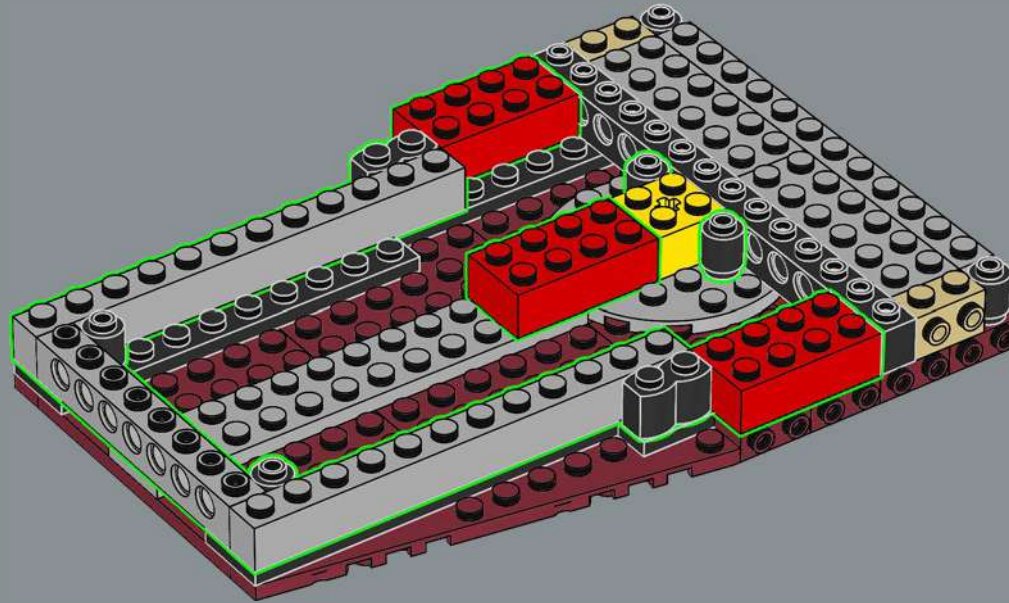

150

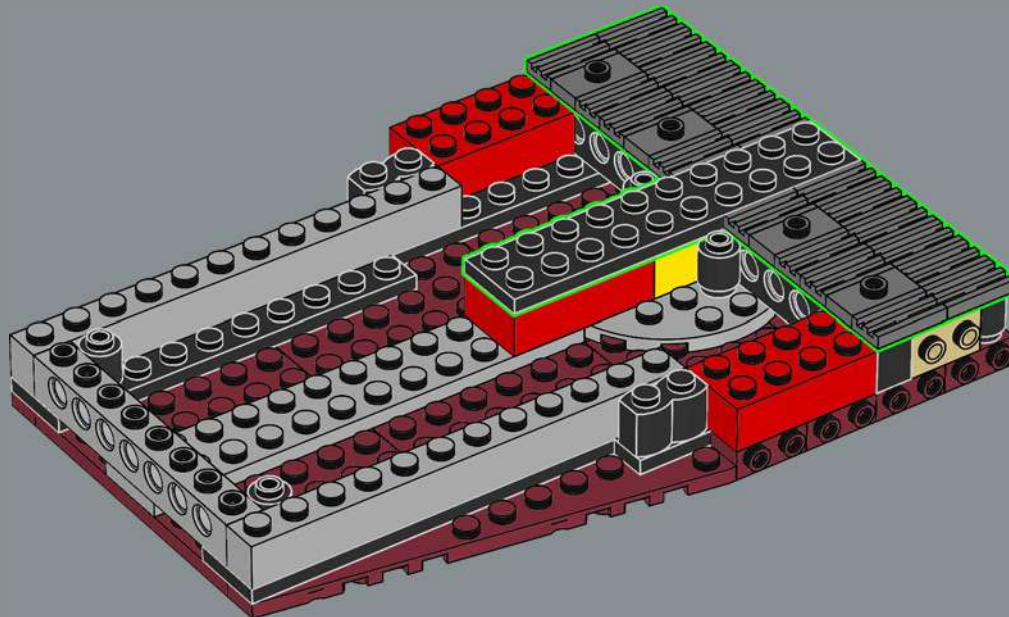

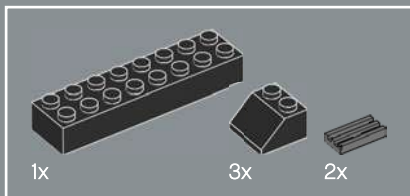

151

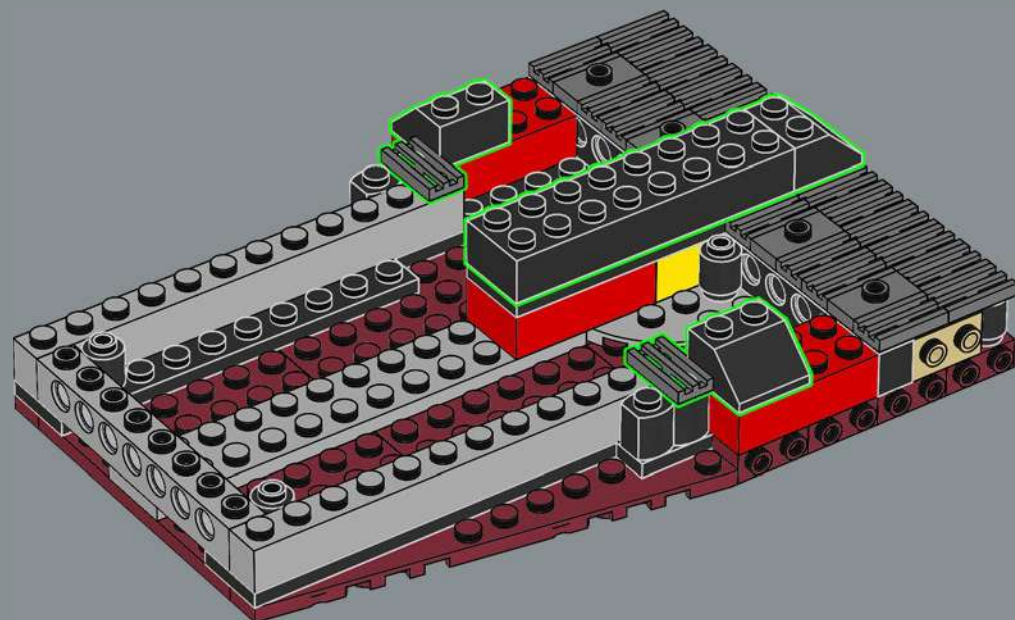

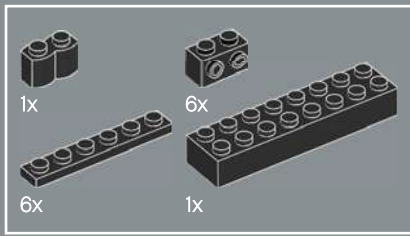

152

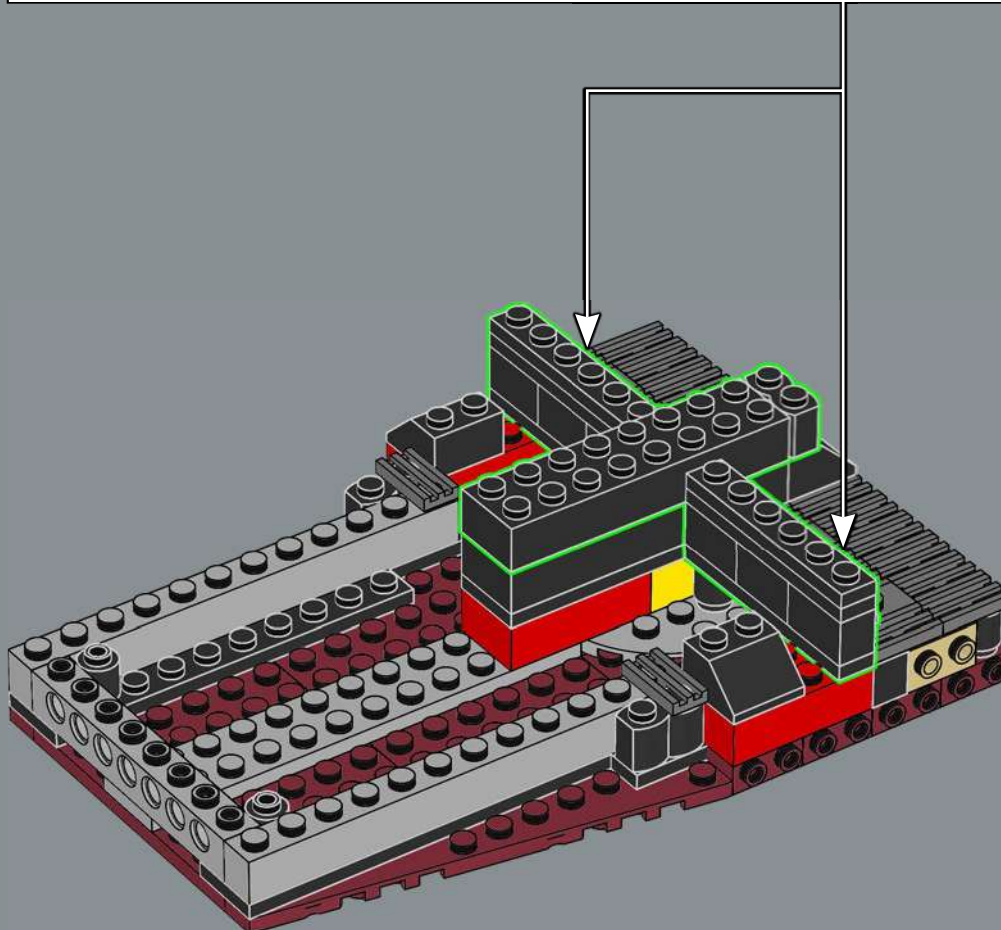
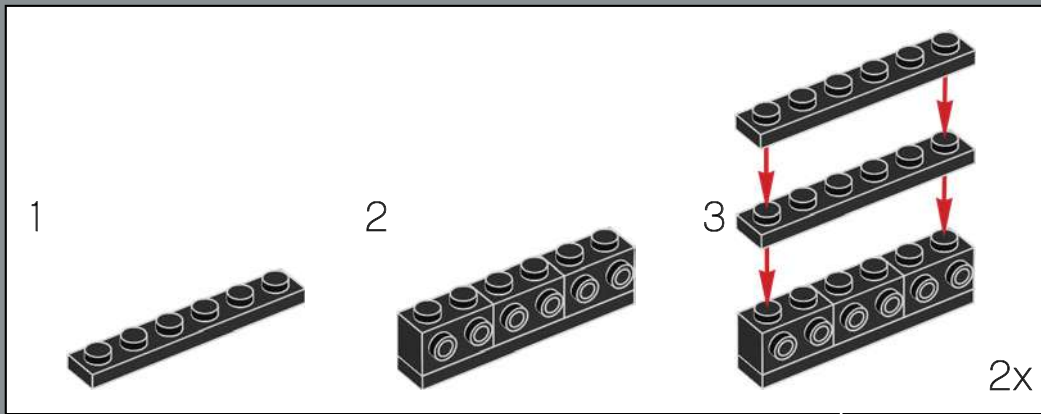

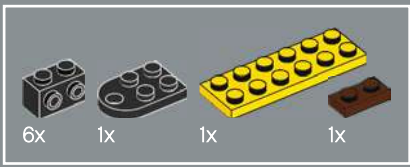

153

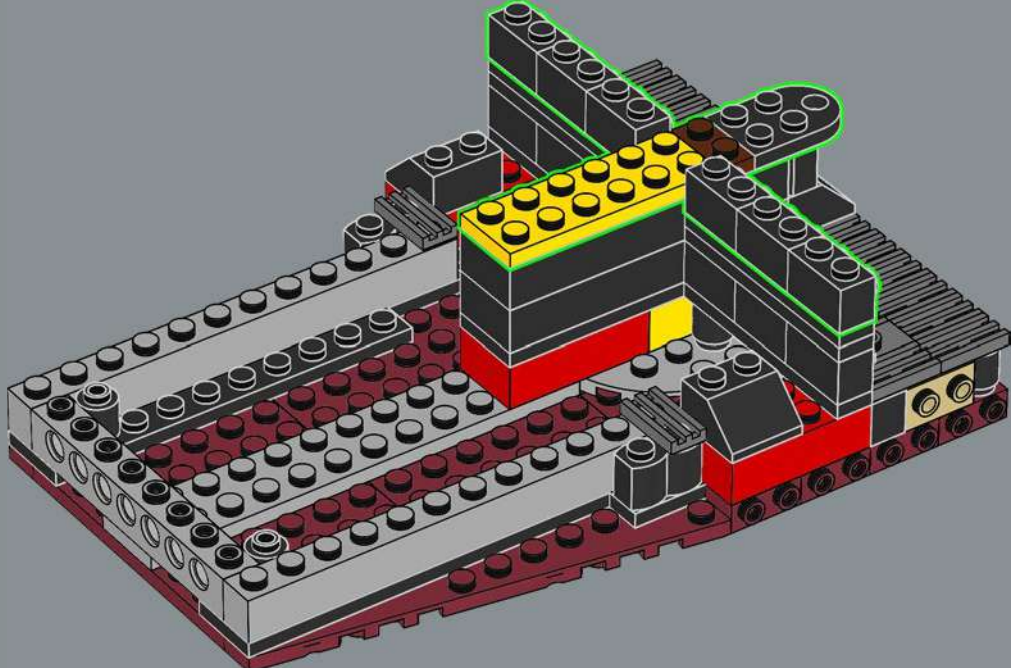

175 firemen worked round the clock shovelling coal into the engines' furnaces.

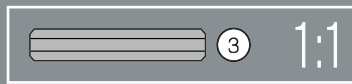
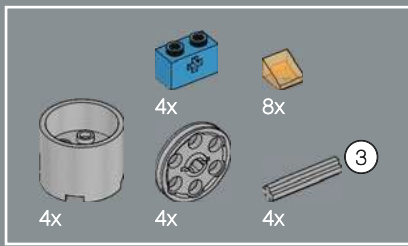

154

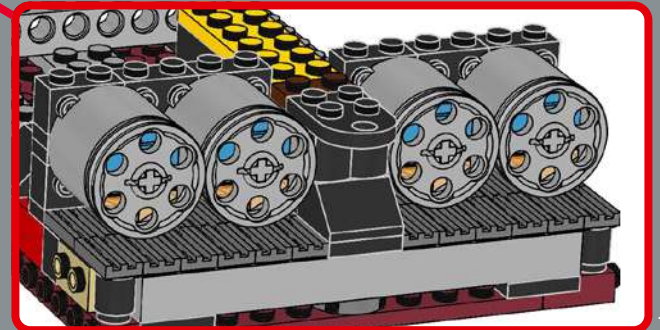
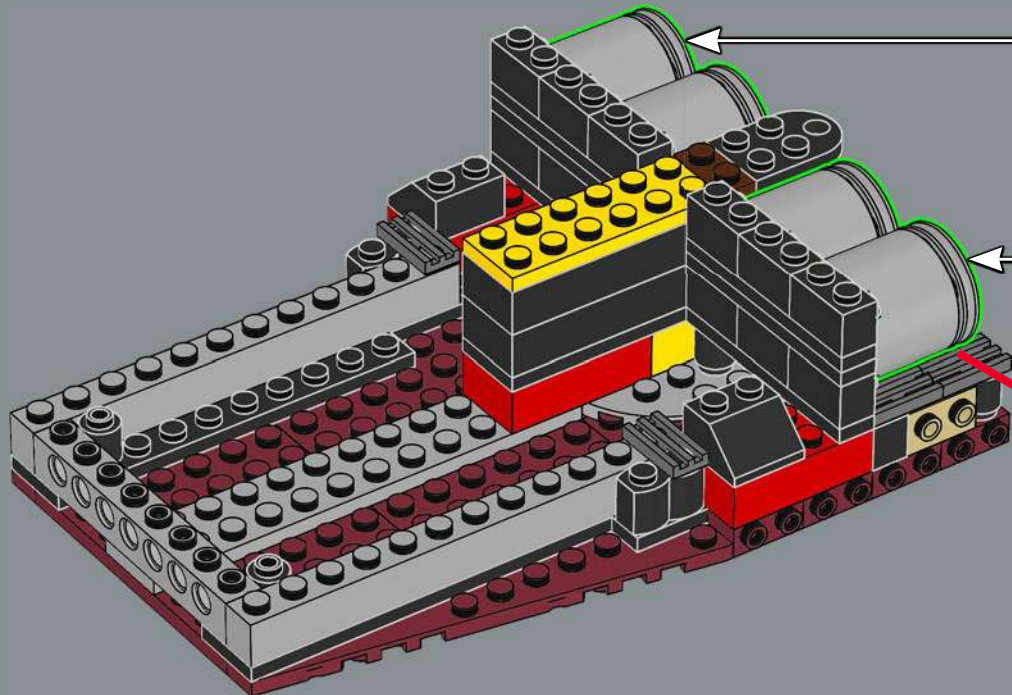
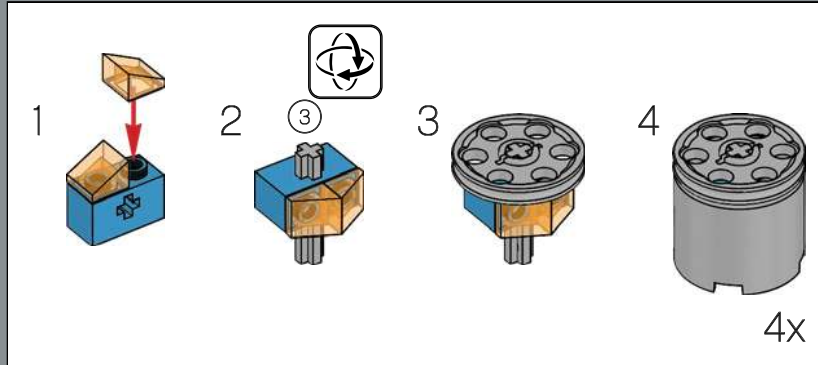

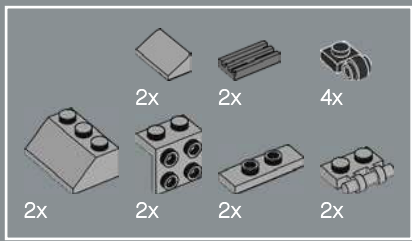

155

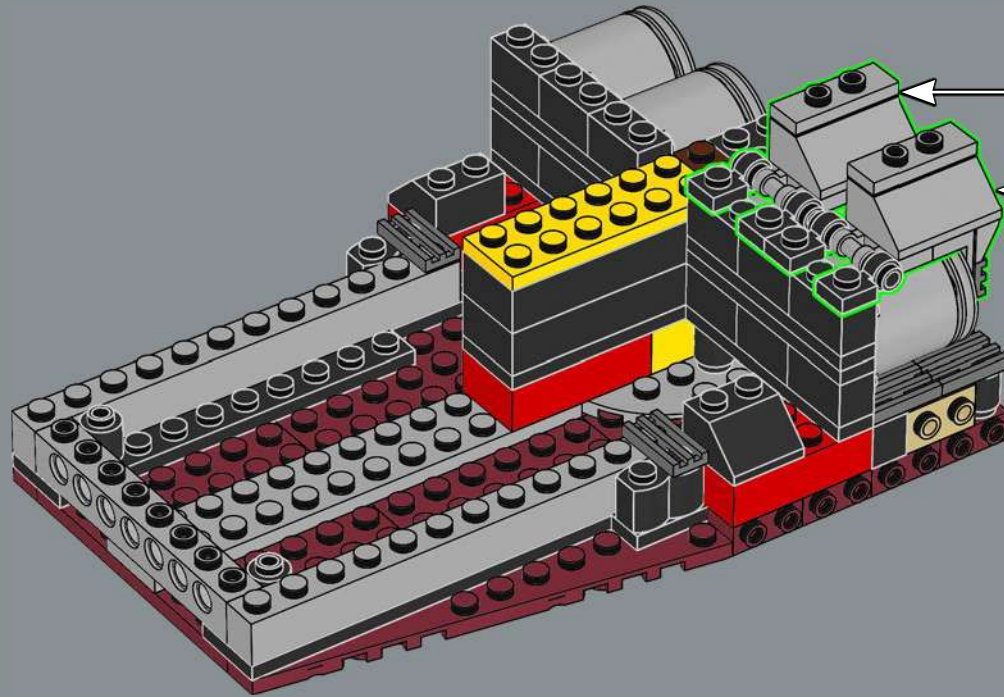
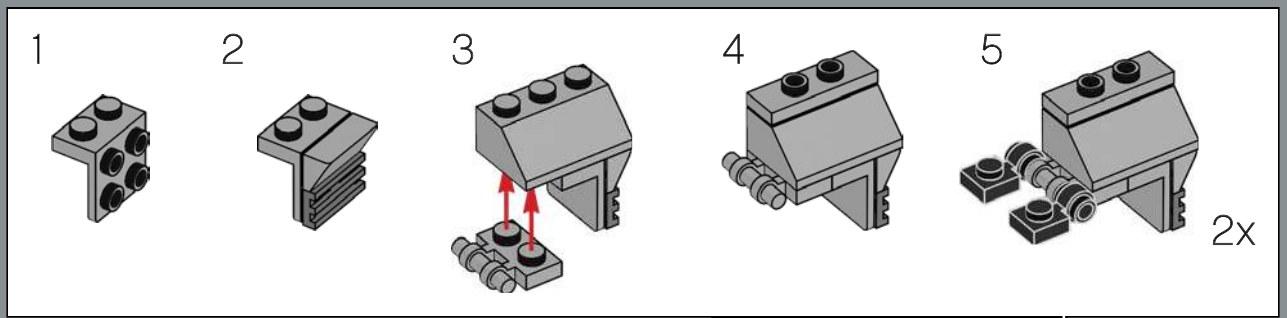

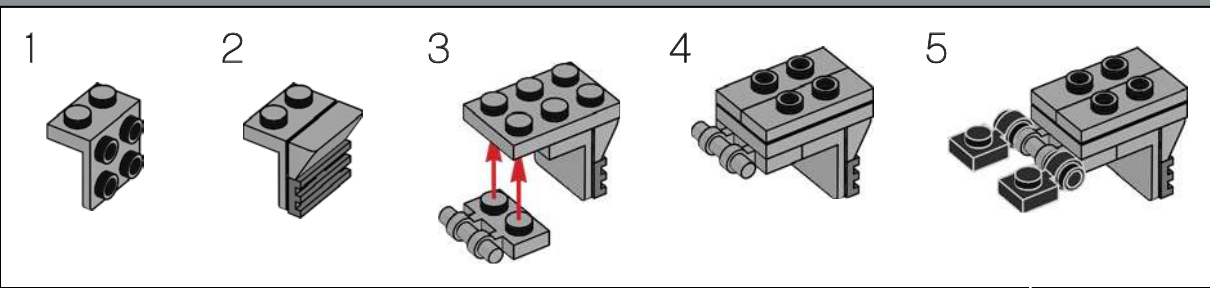
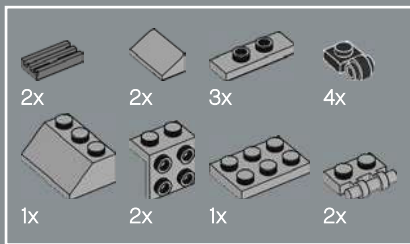

156

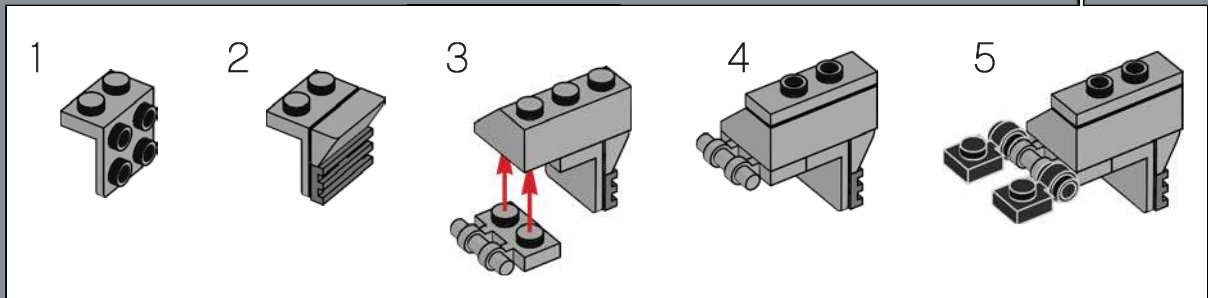
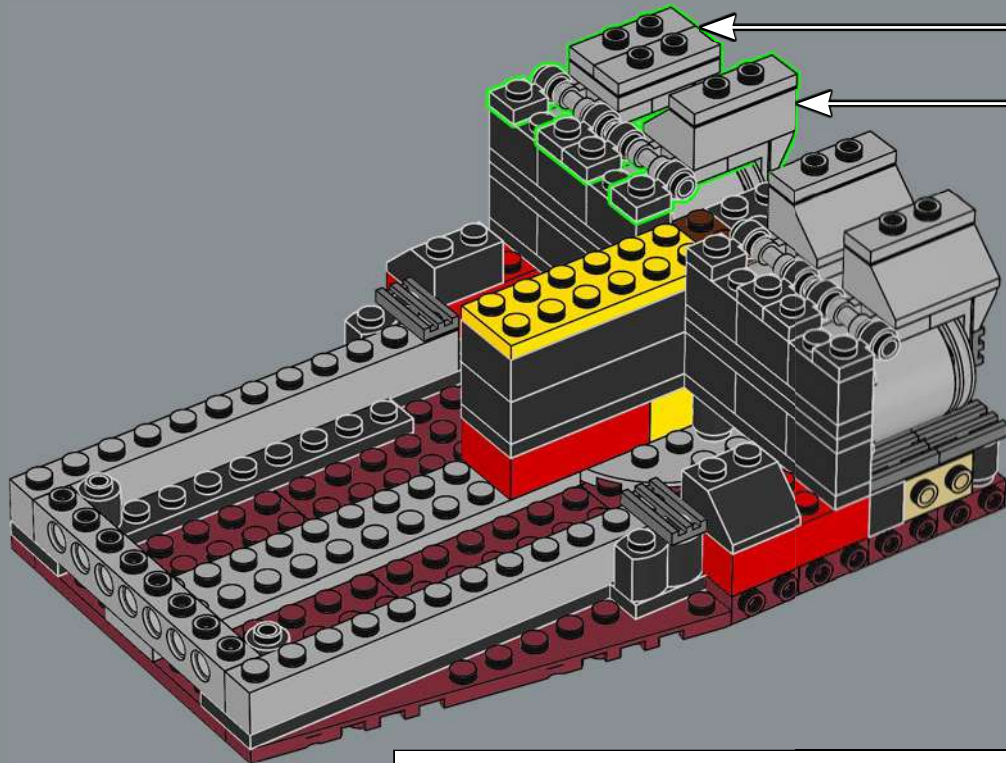

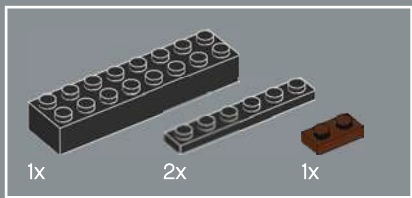

157

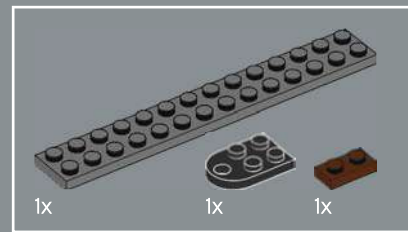
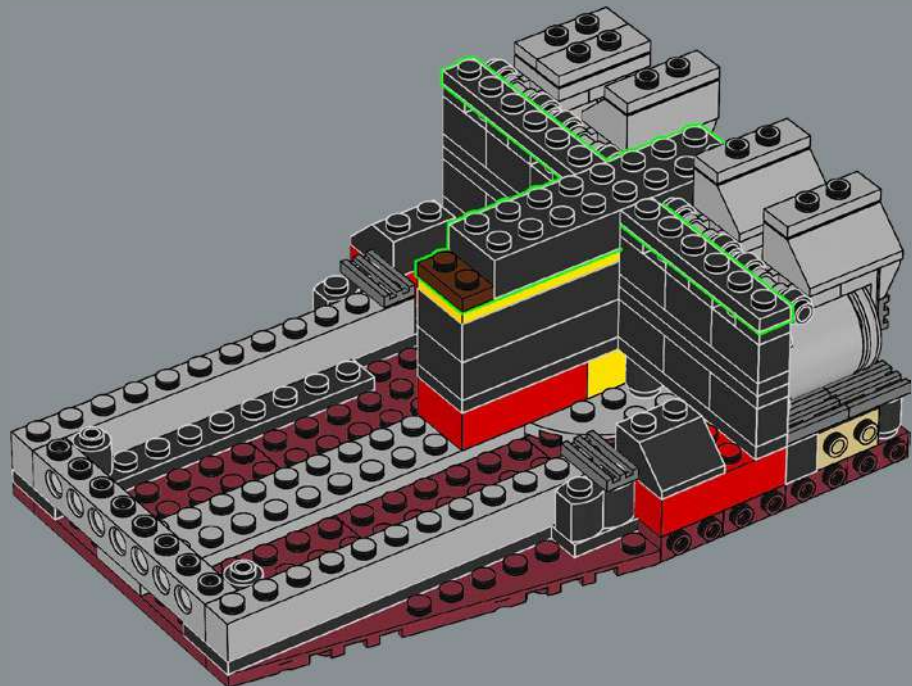

158

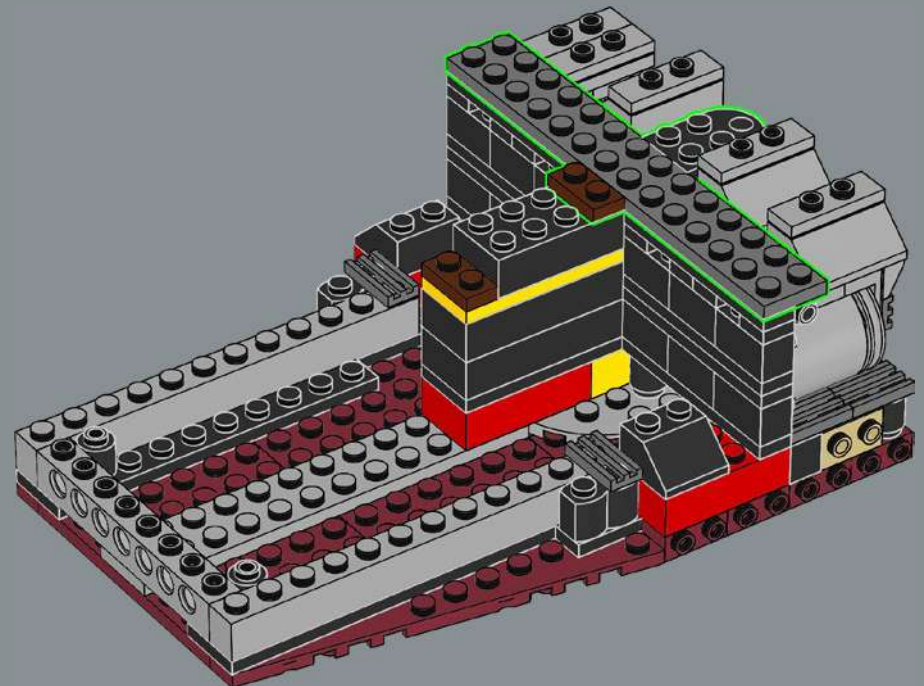

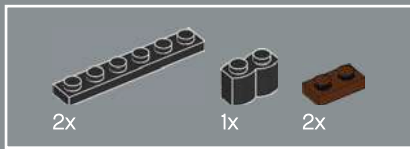

159

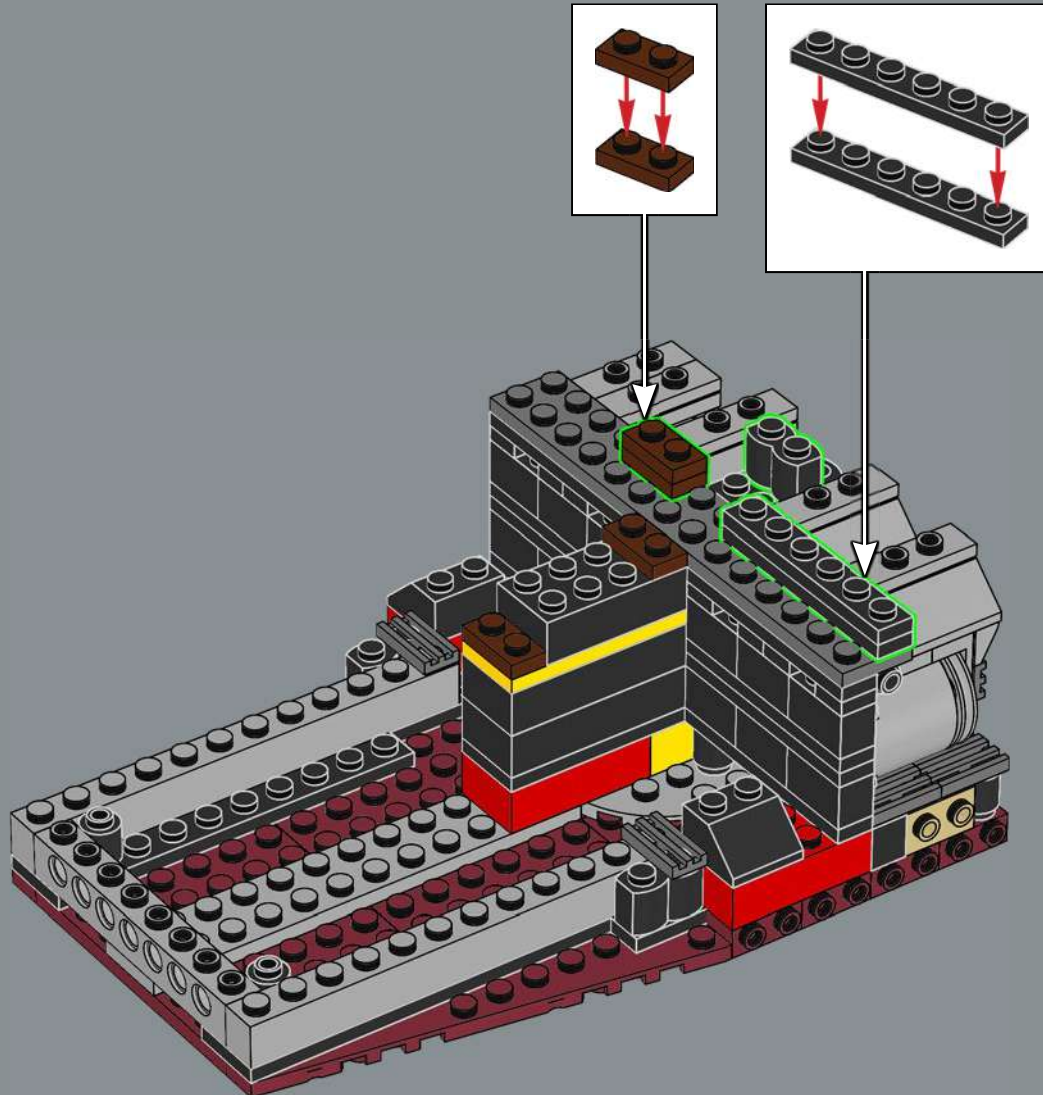

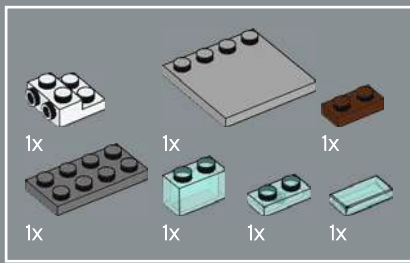

160

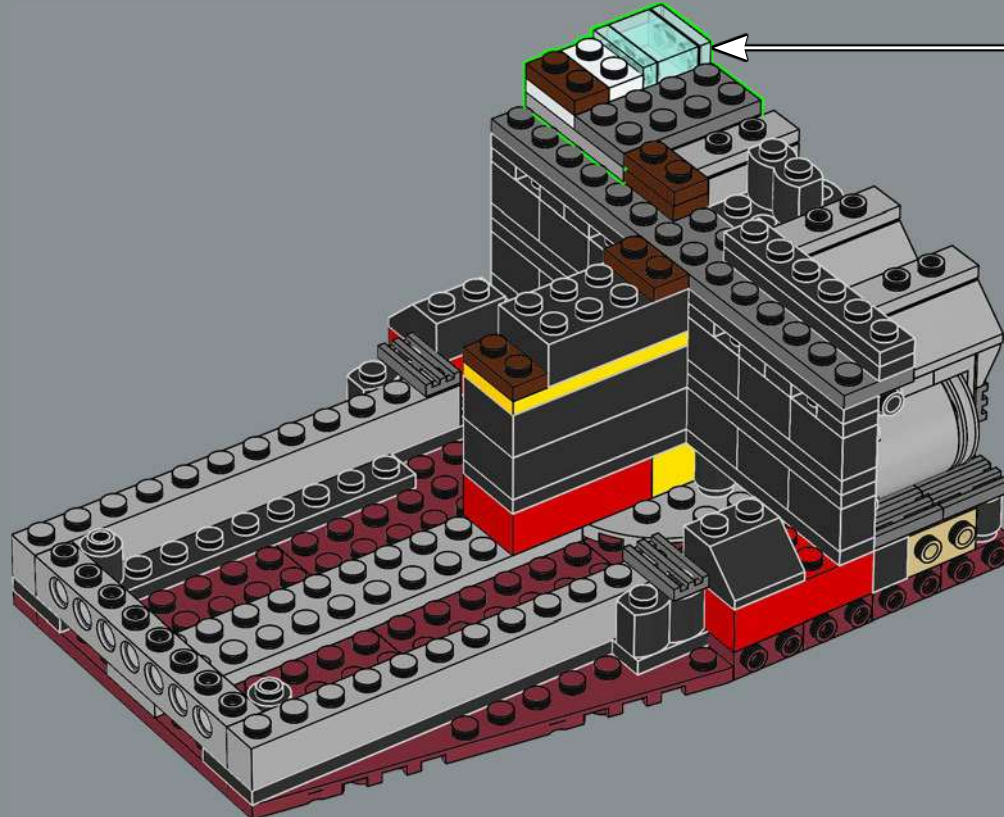
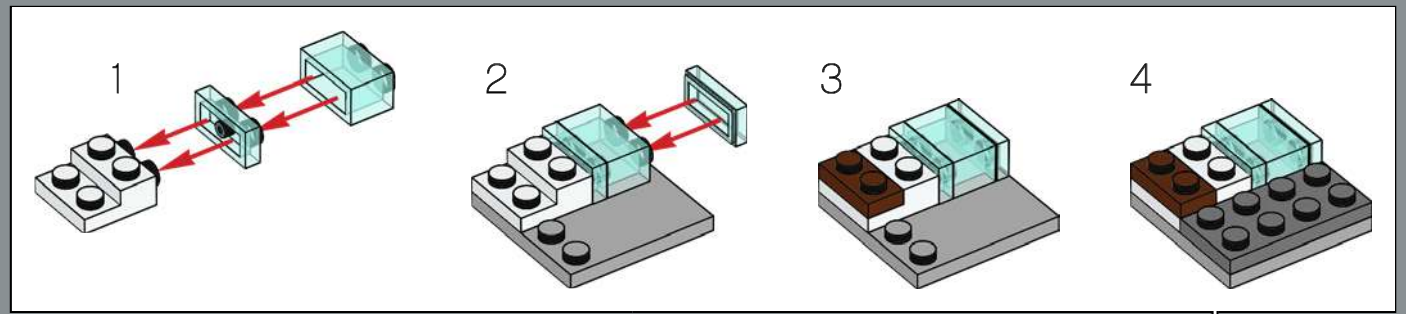

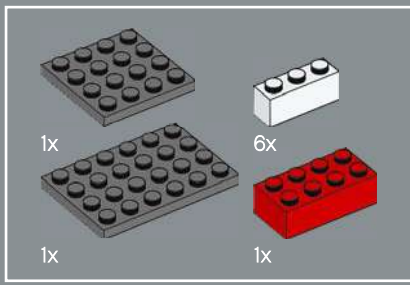

161

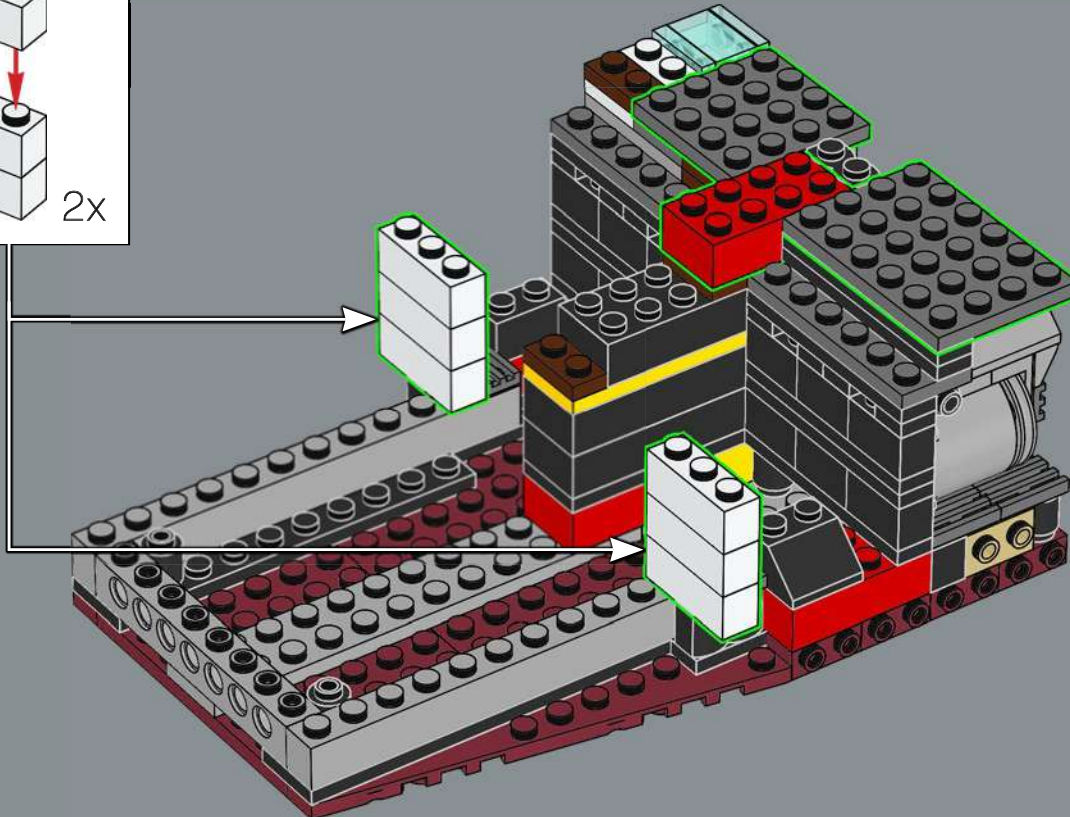
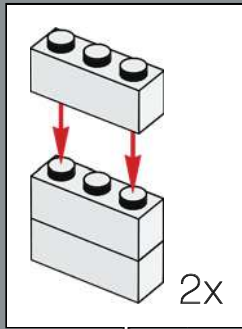

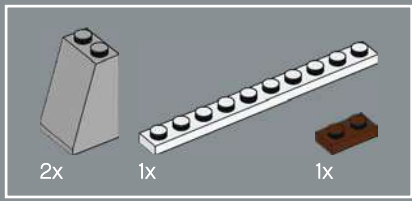

162

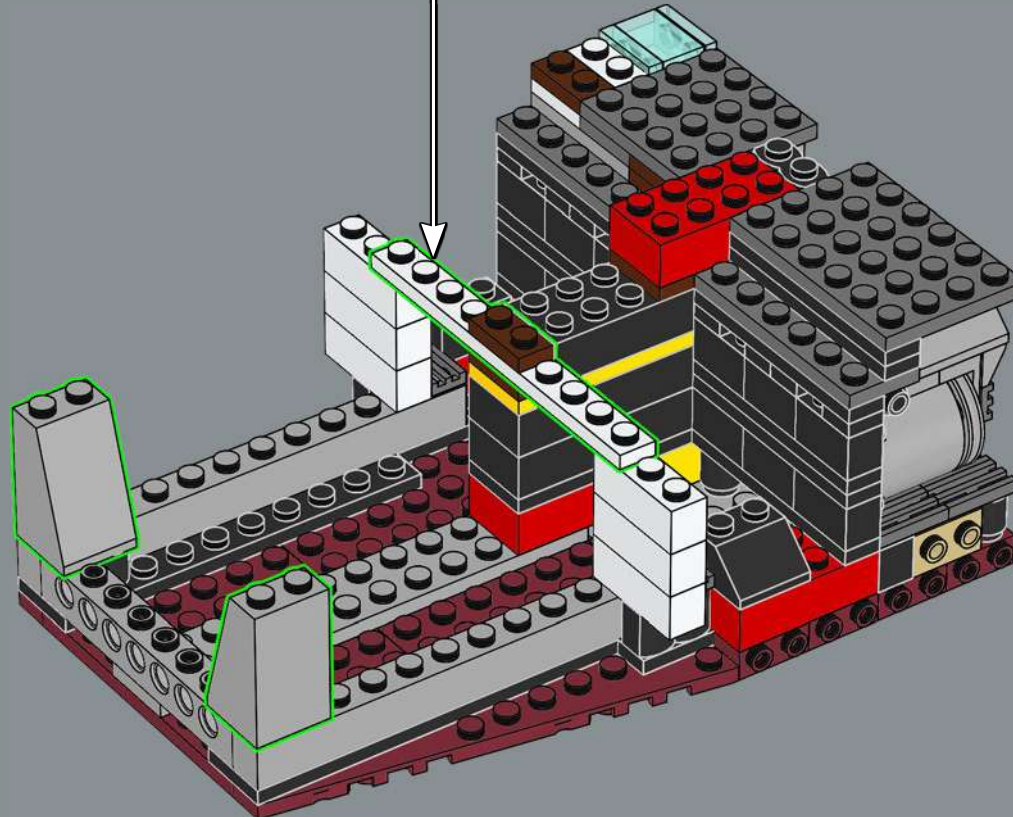
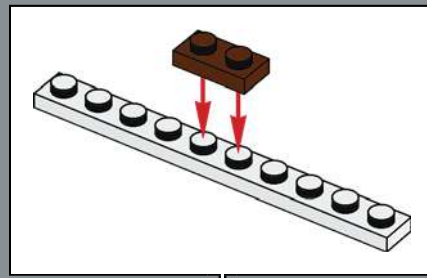

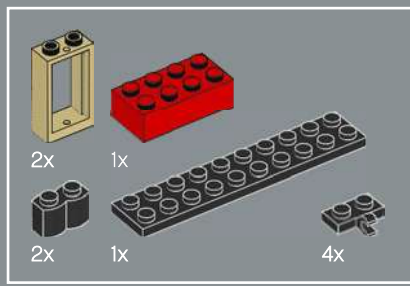

163

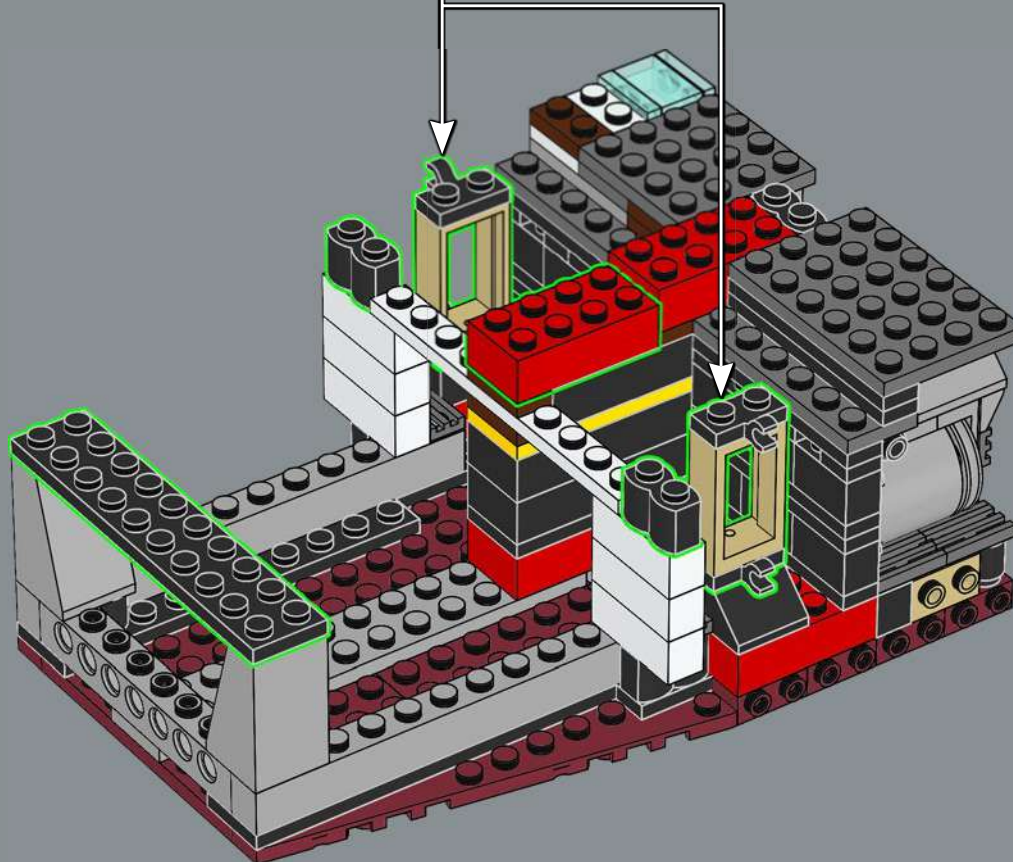
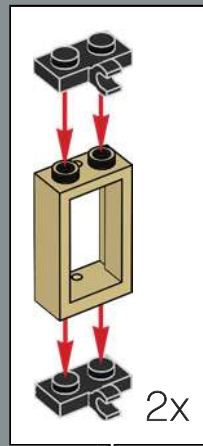

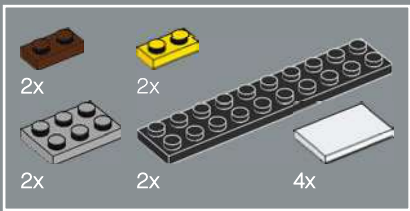

164

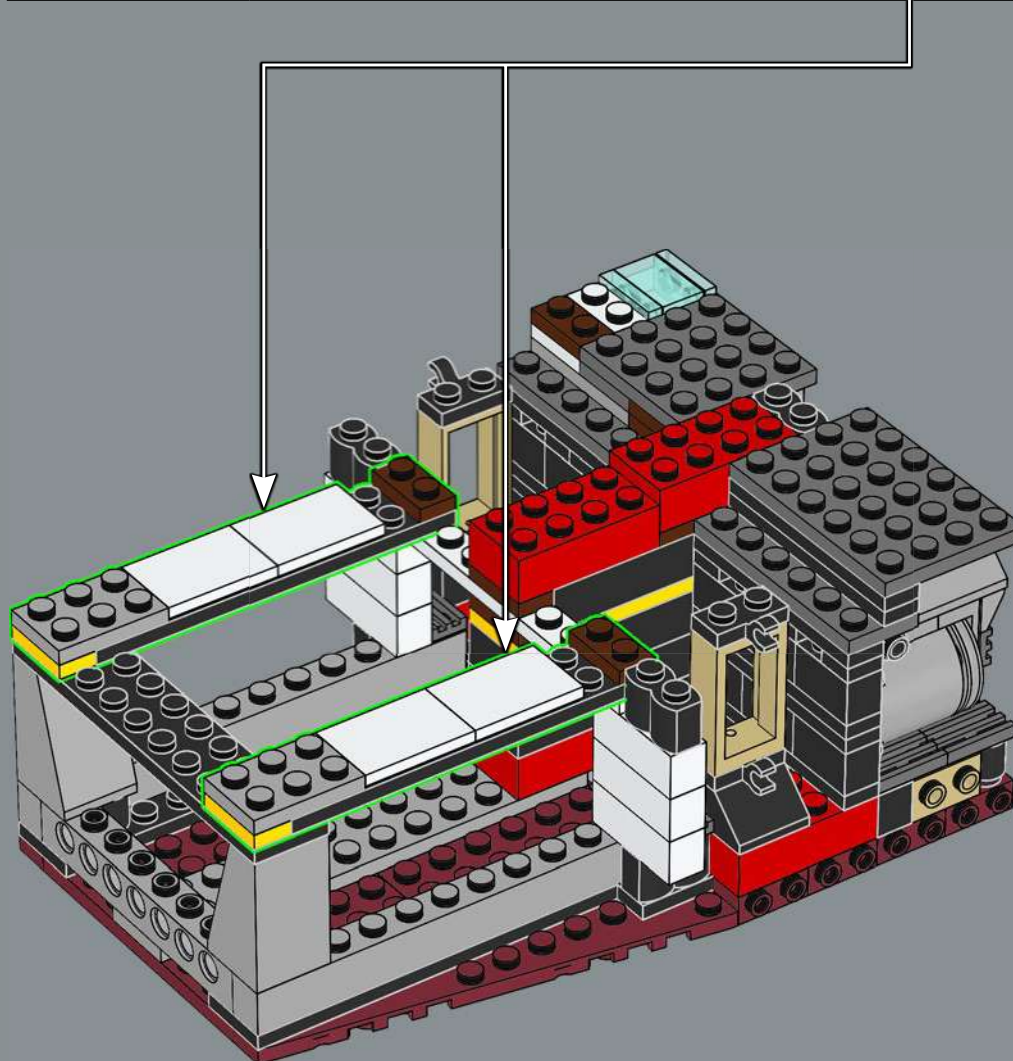
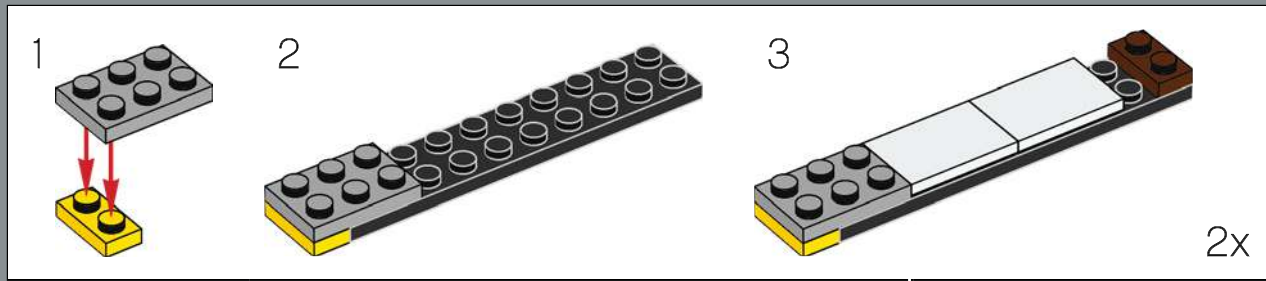

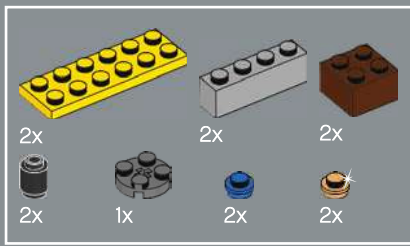

165

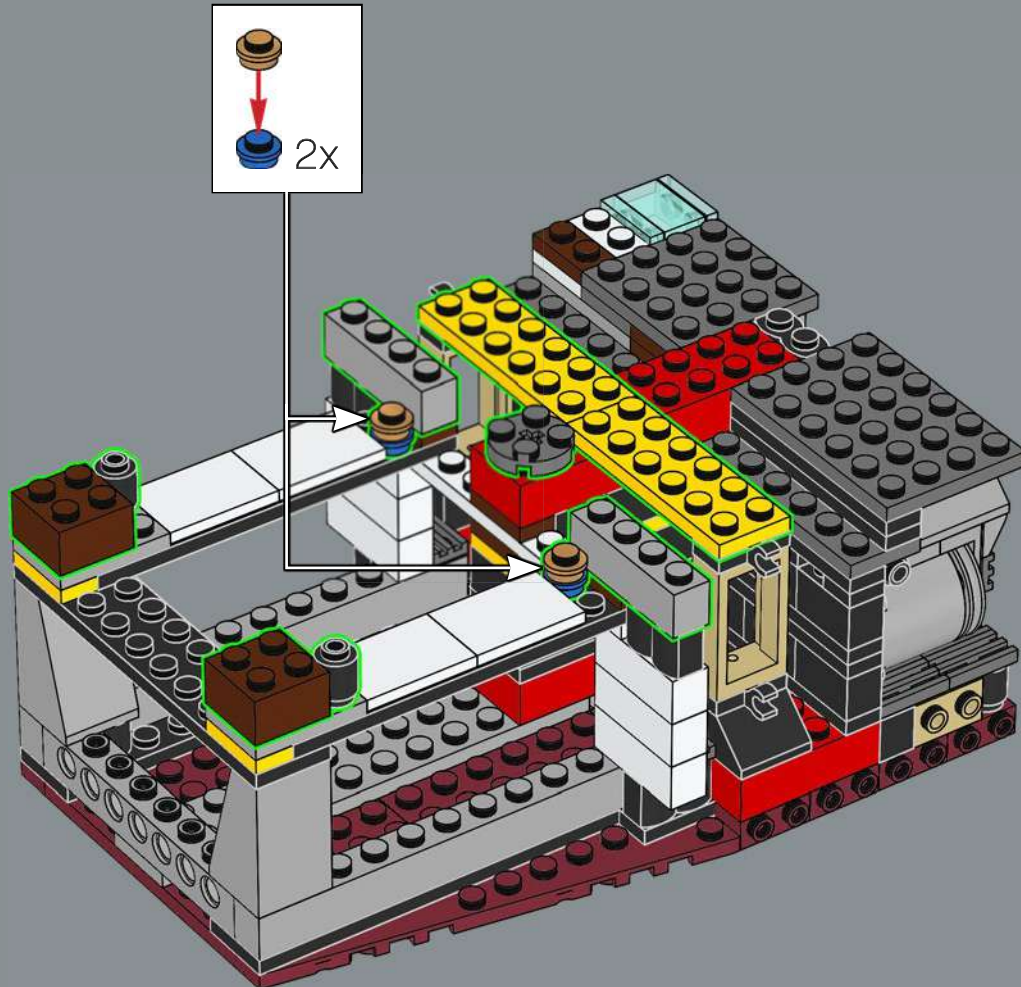

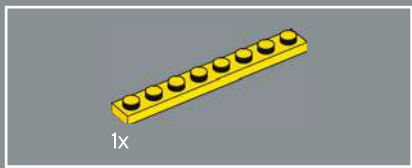

166

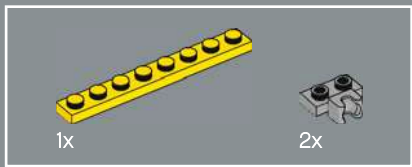
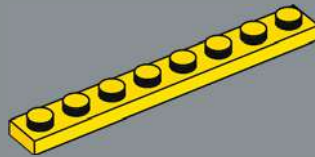

167

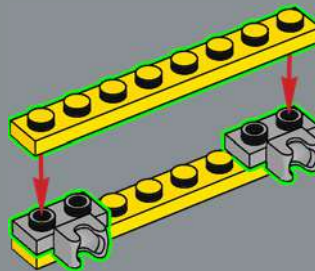

168

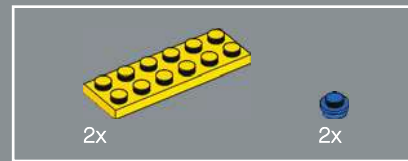
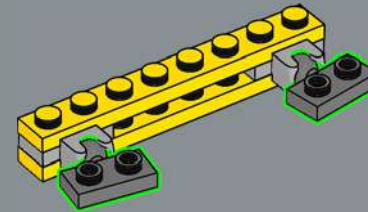

169

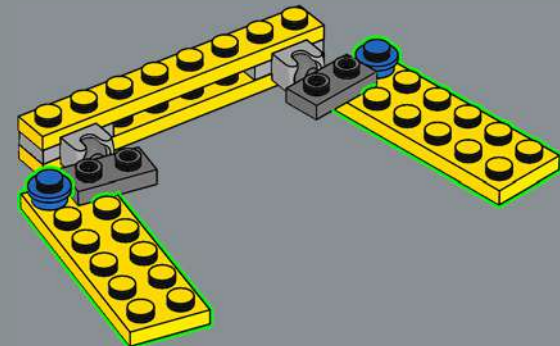

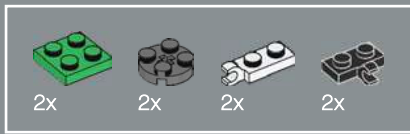

170

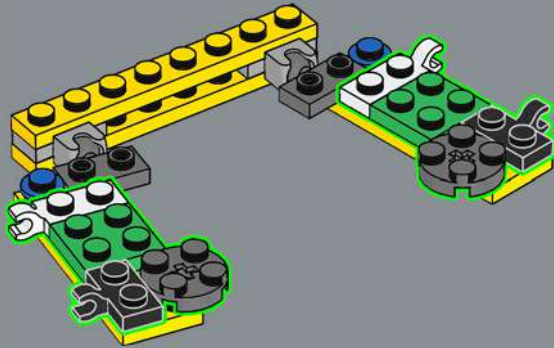

171

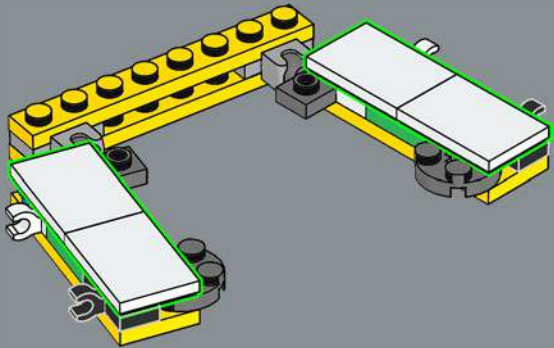

172

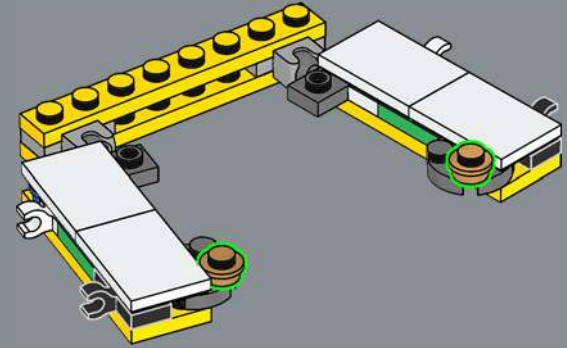

173

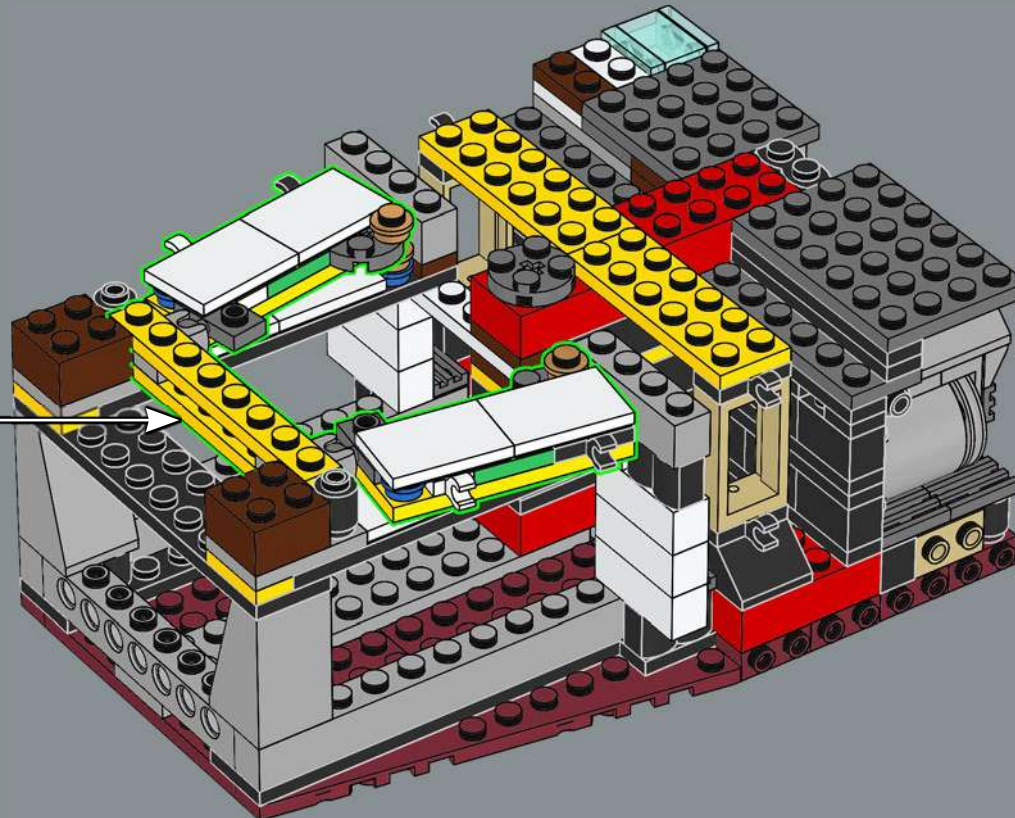

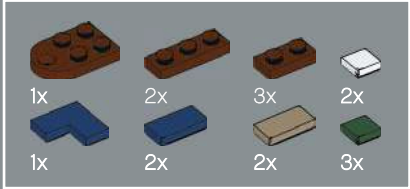
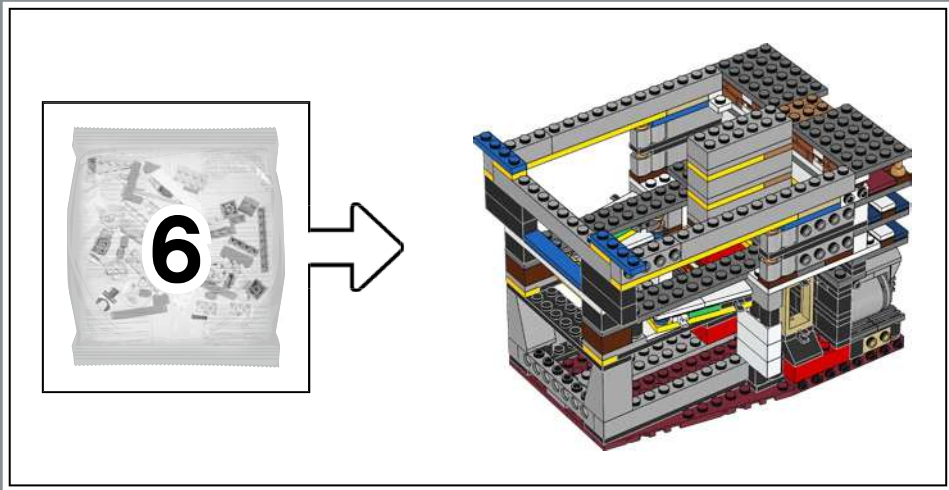

174

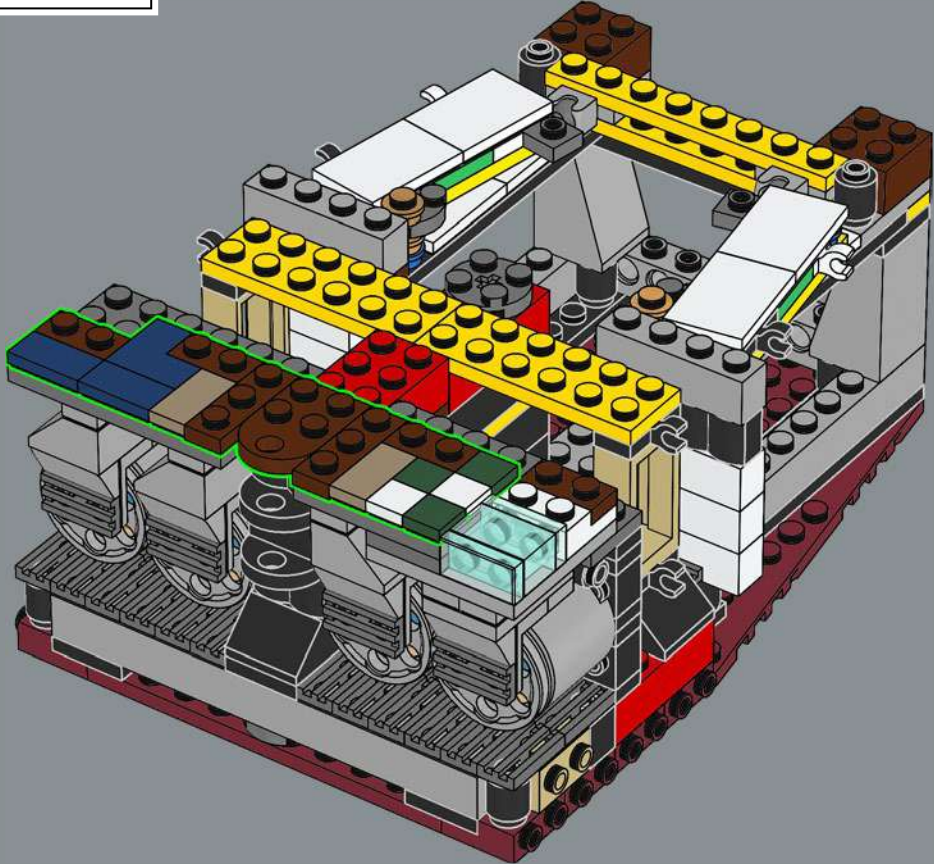

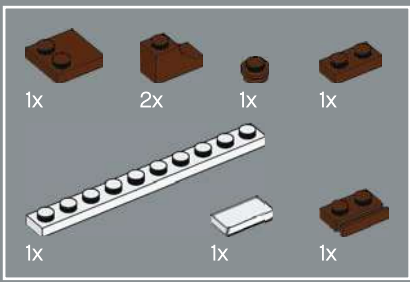

175

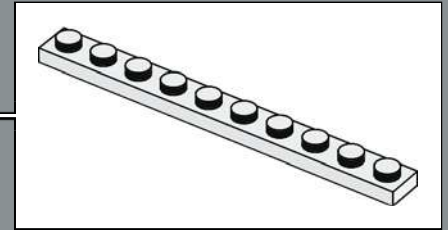
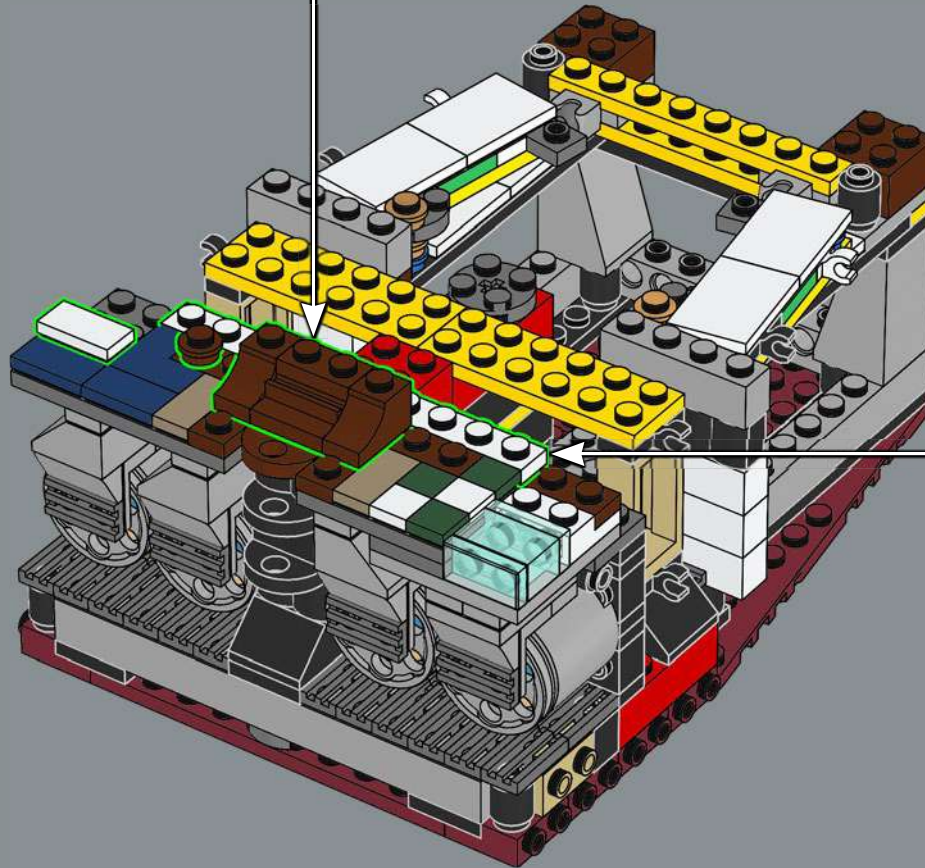
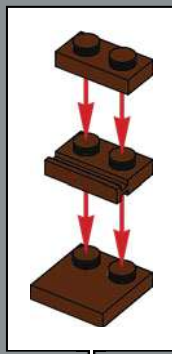

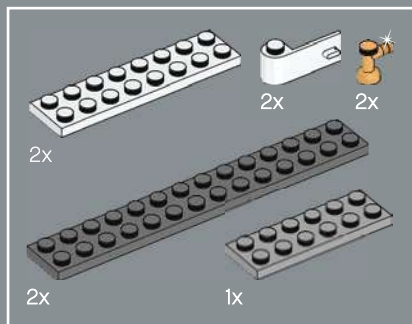

176

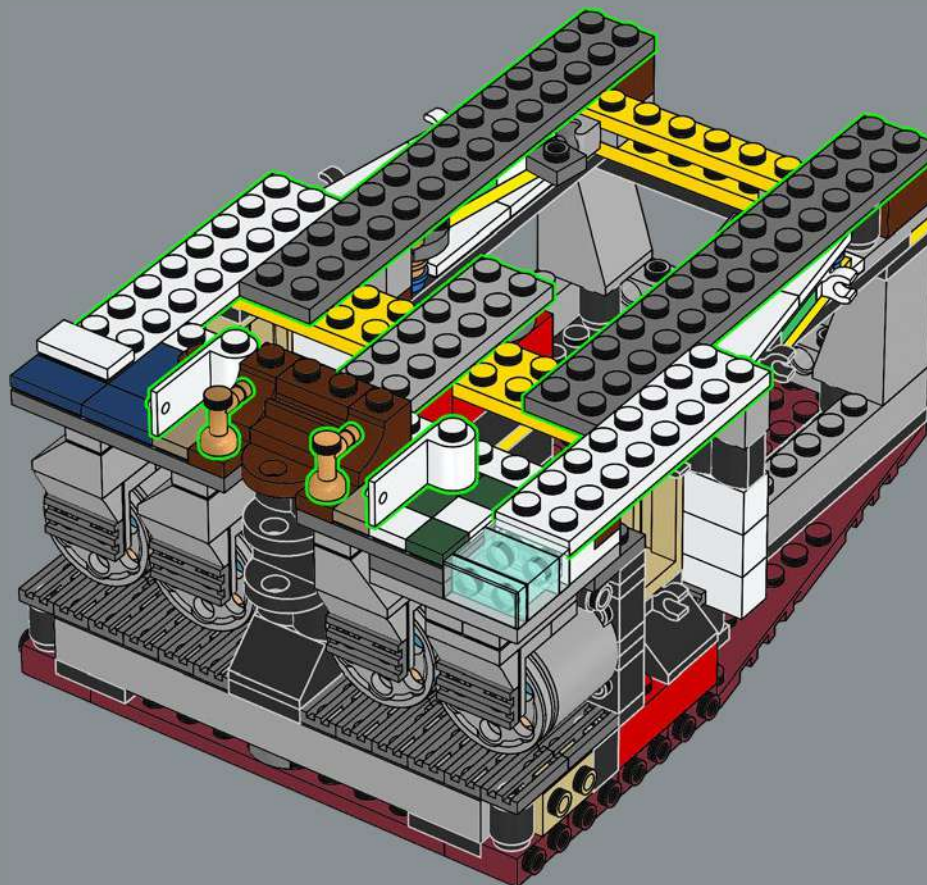

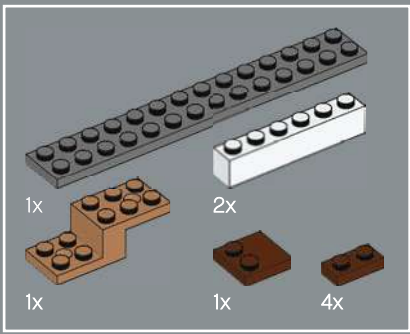

177

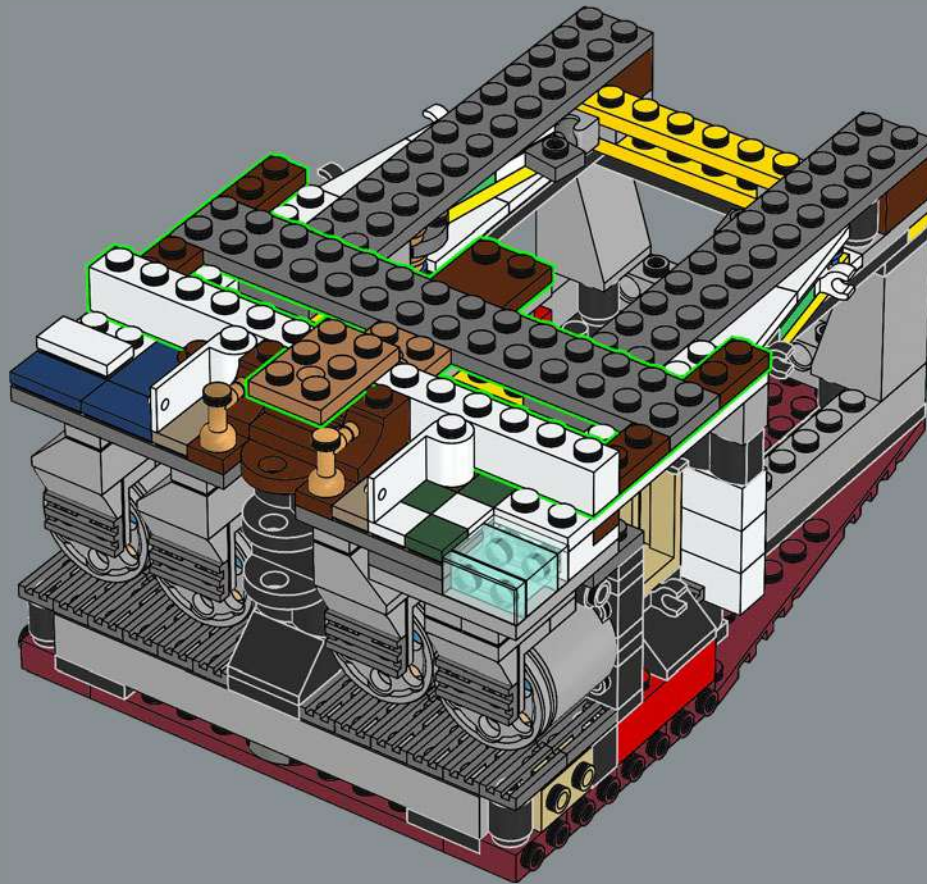

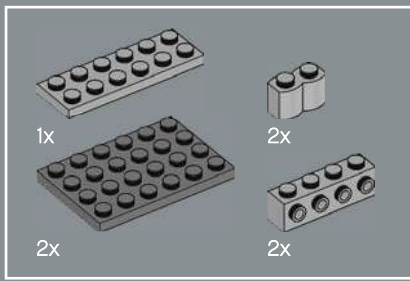

178

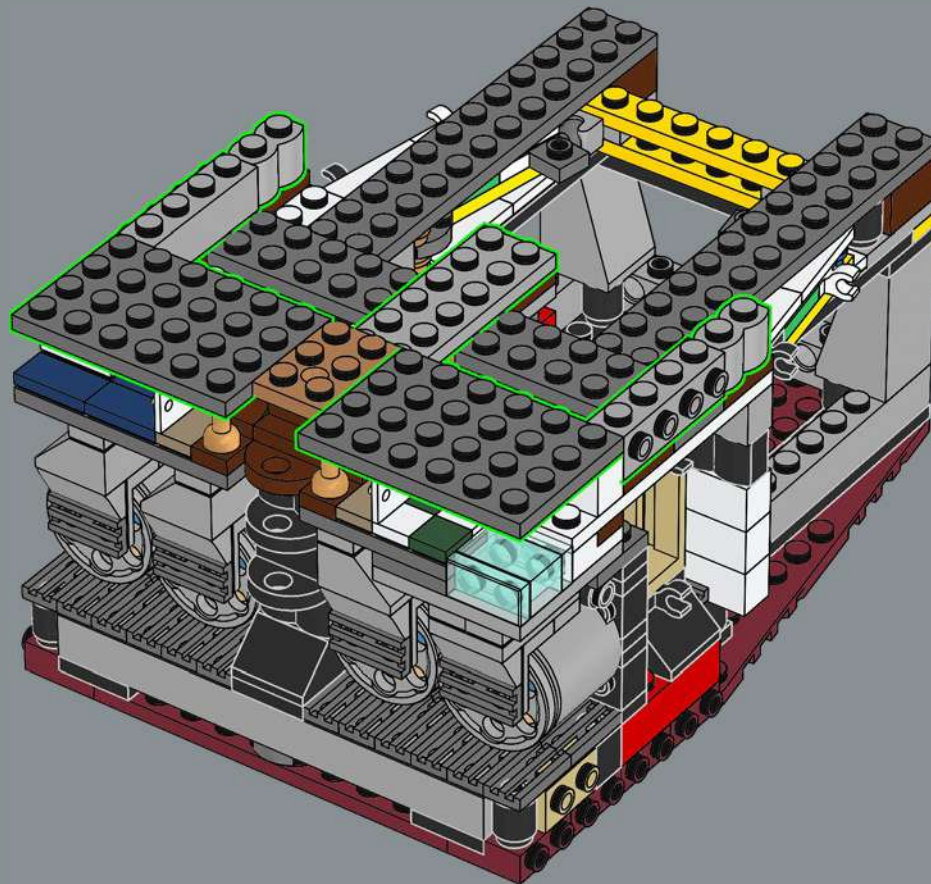

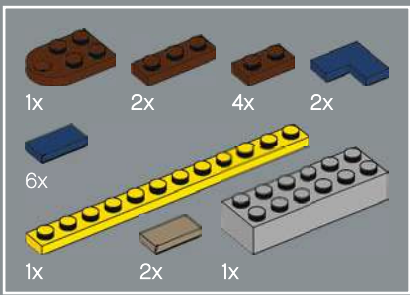

179

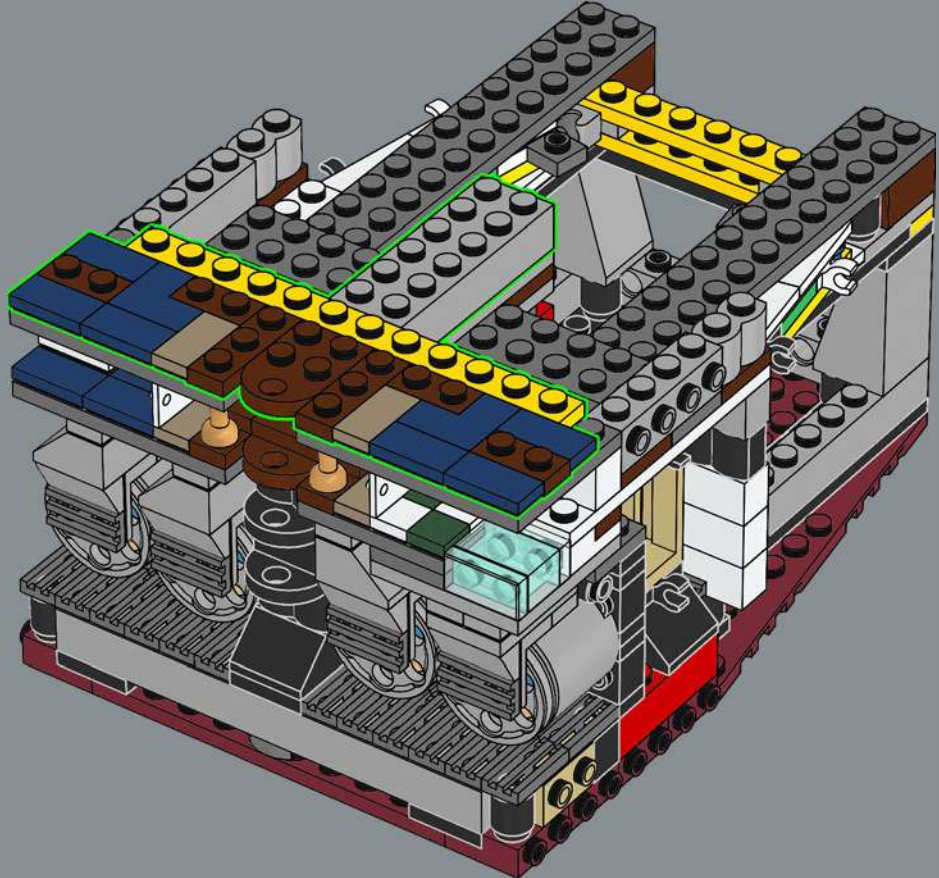

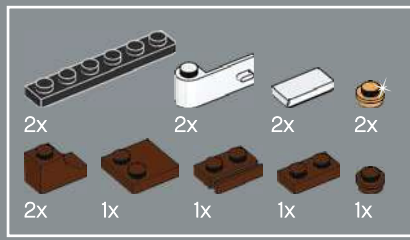

180

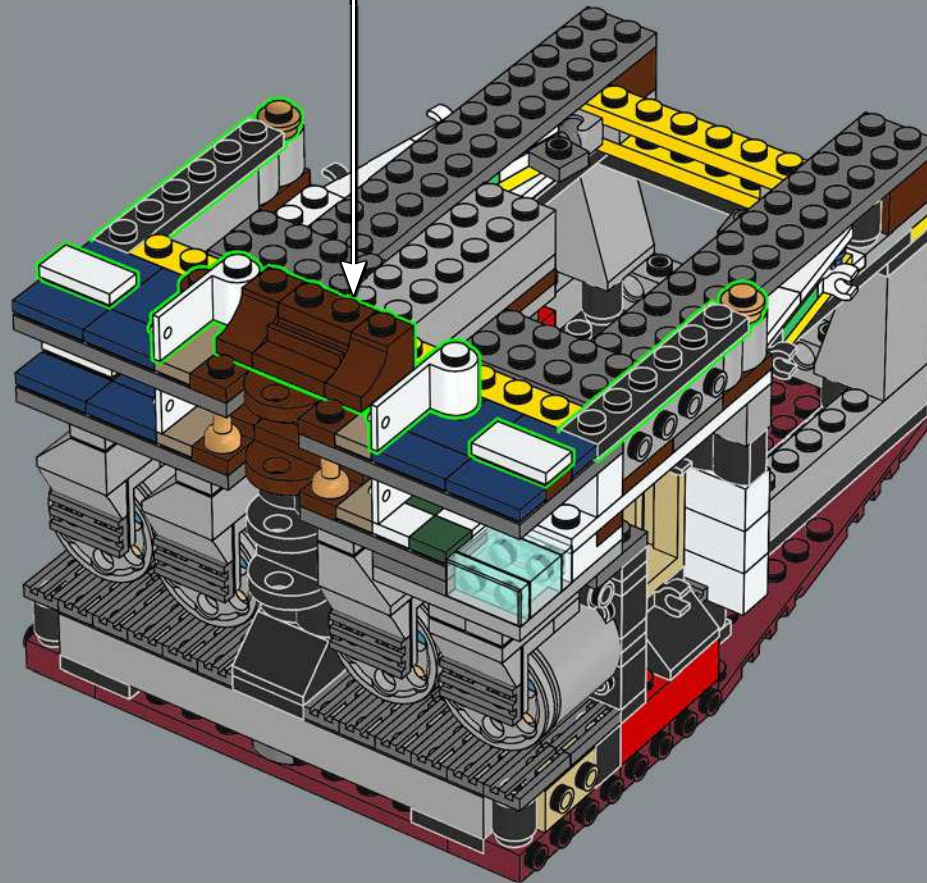
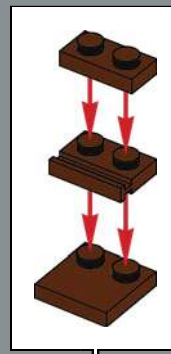

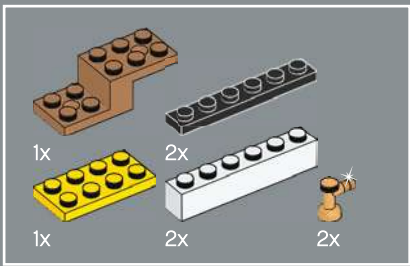

181

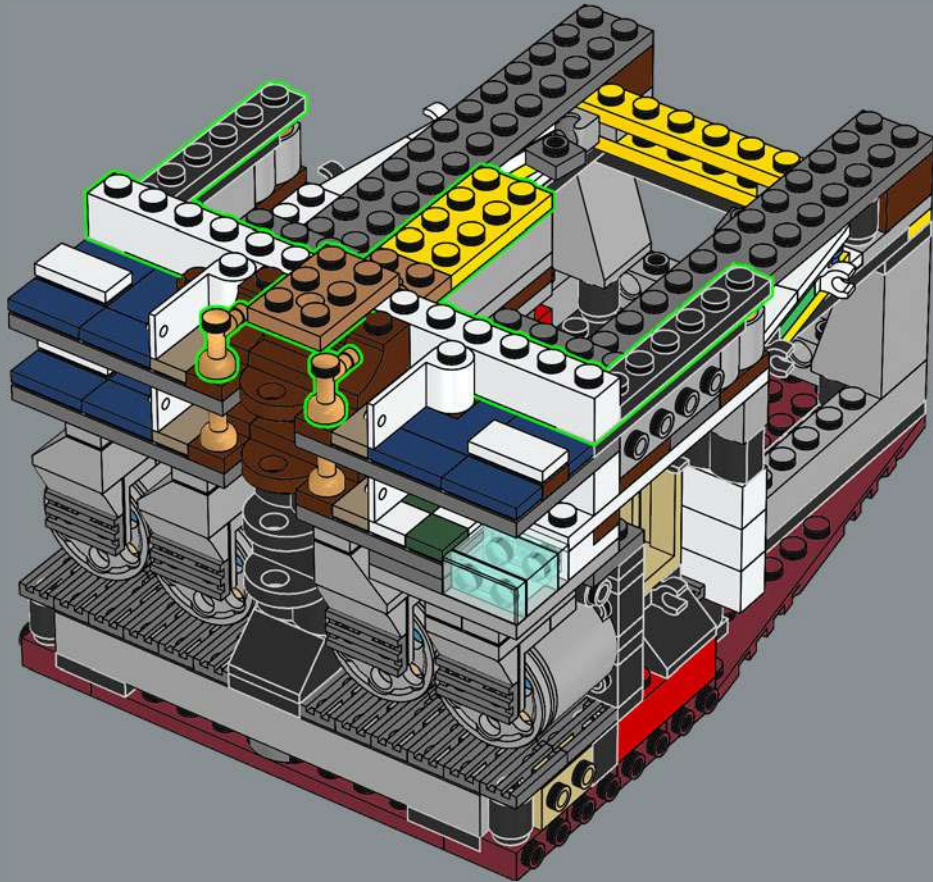

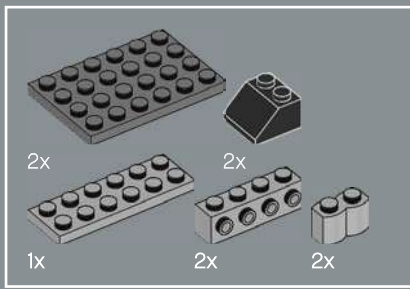

182

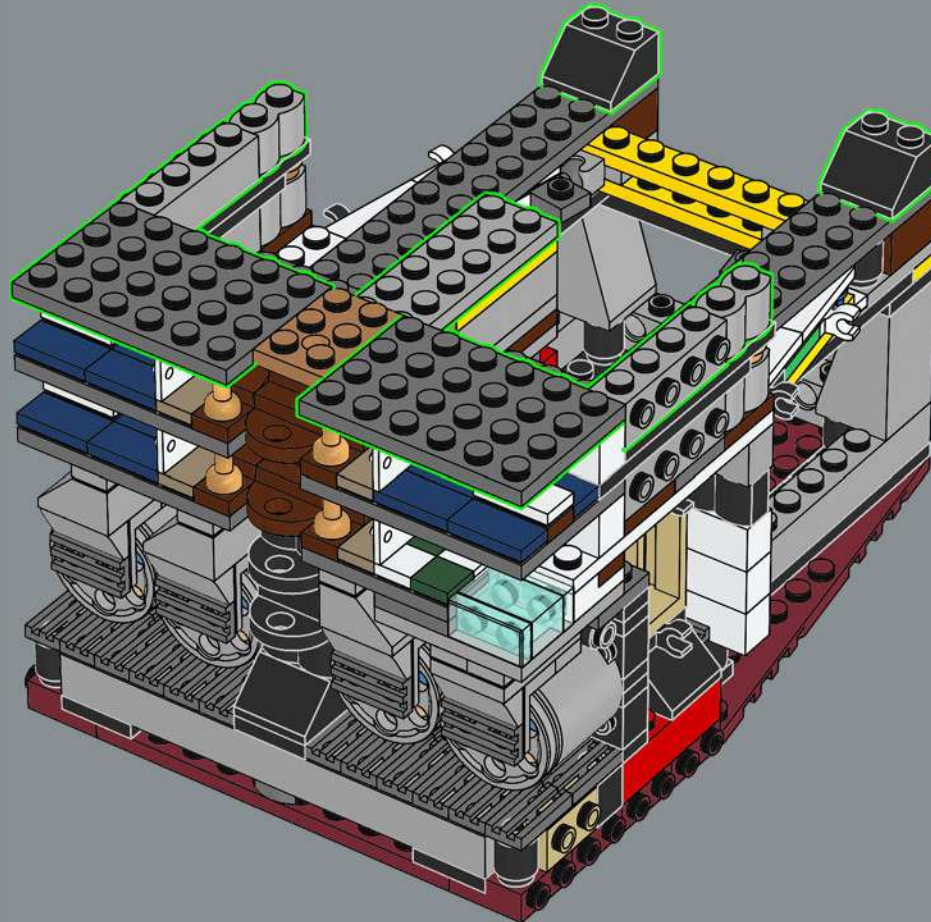

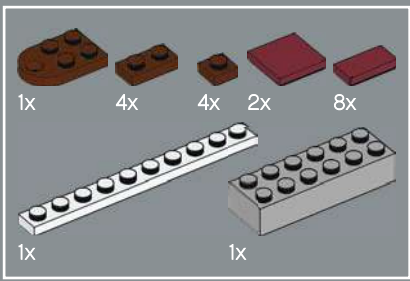

183

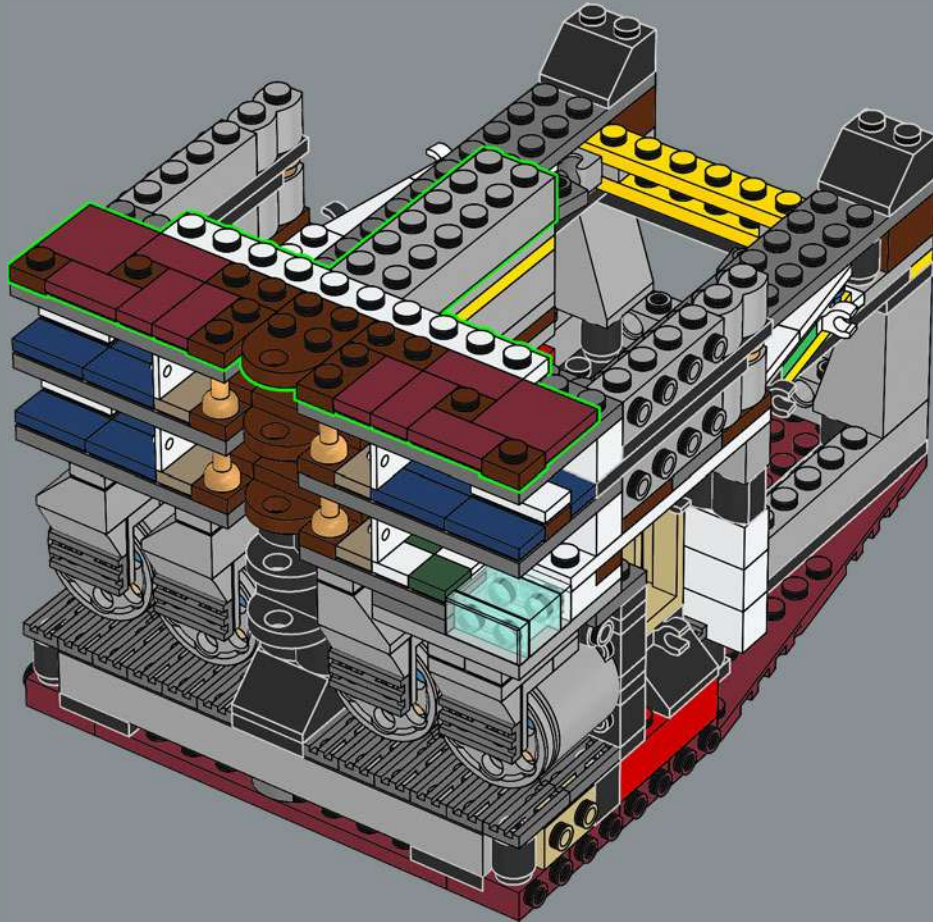

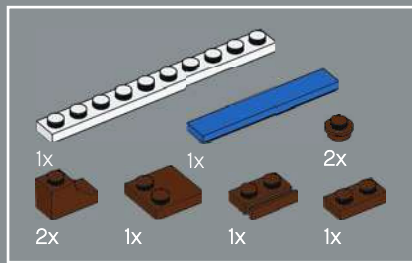

184

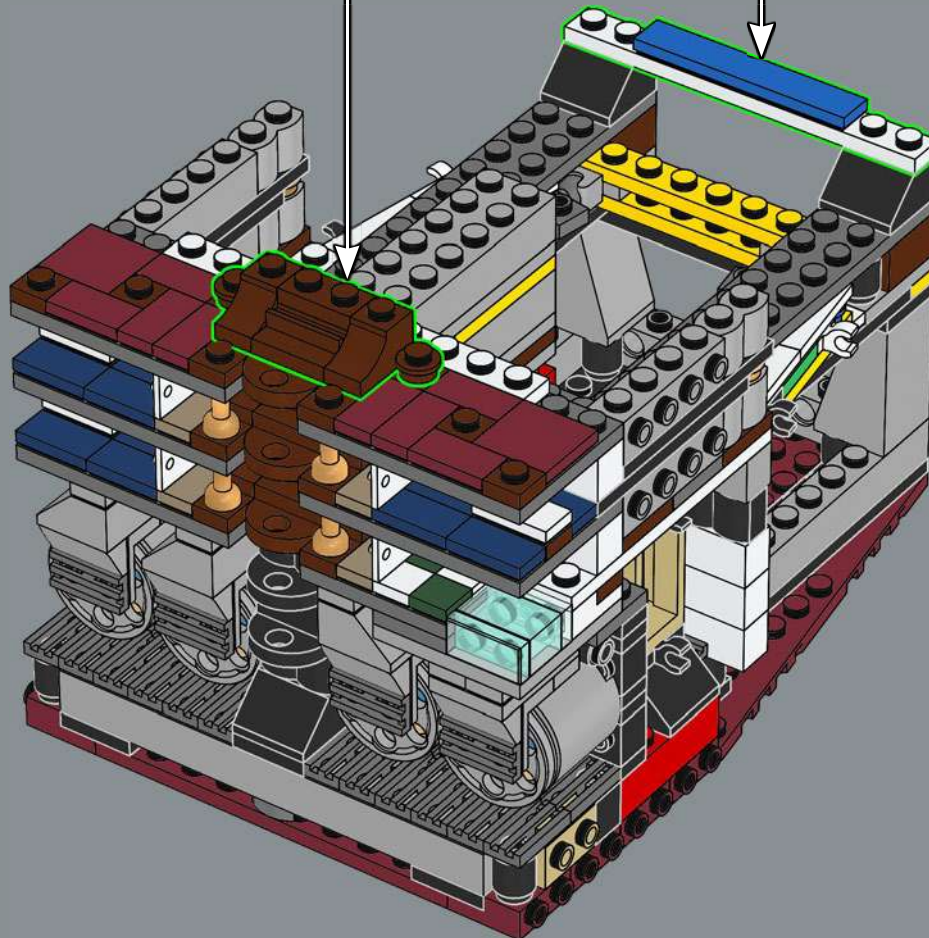
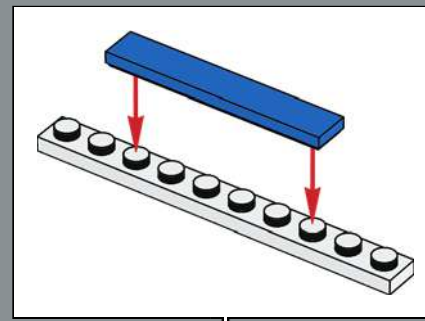
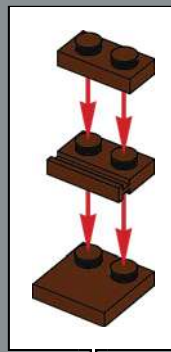

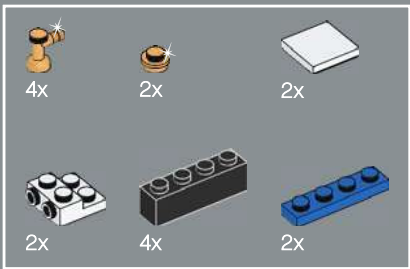

185

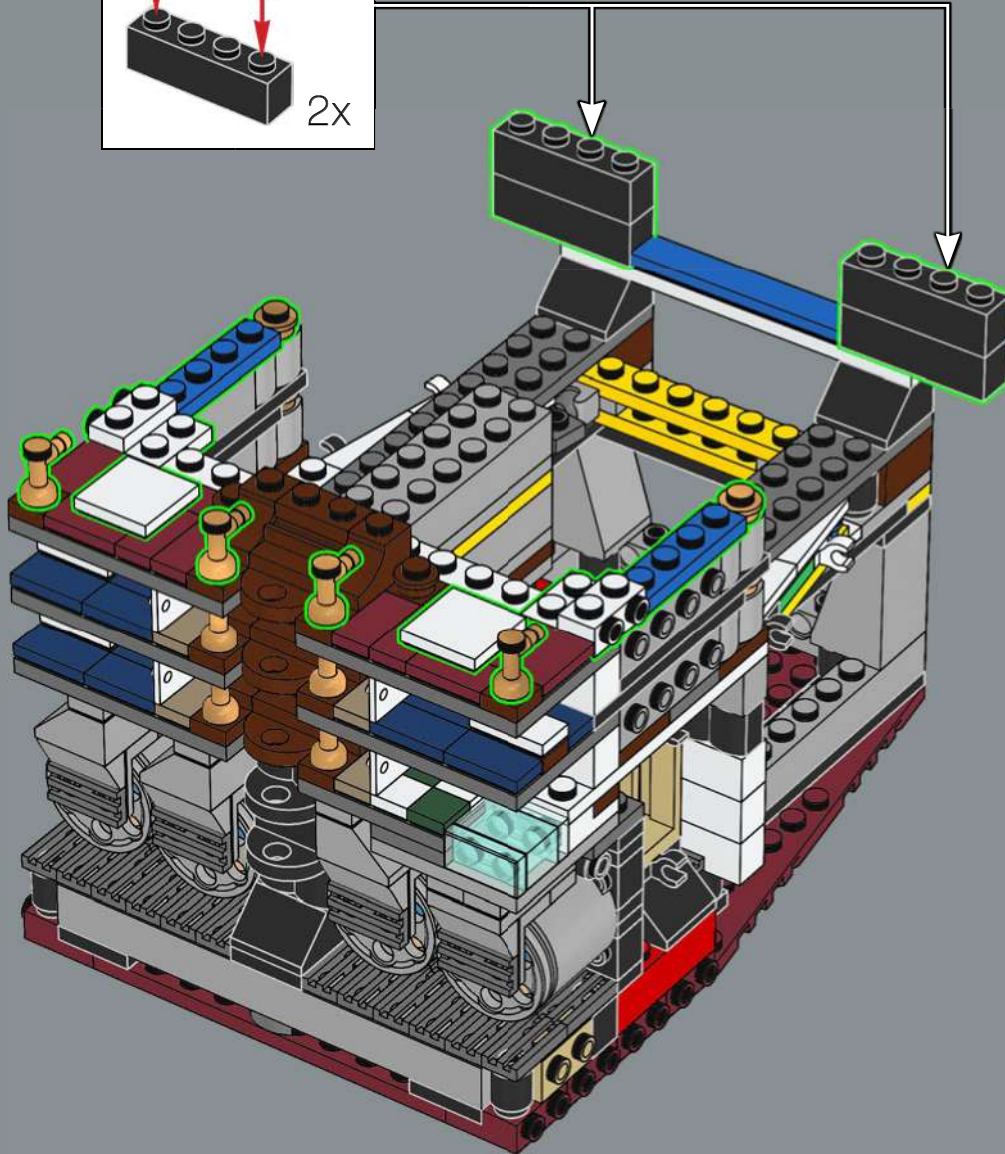
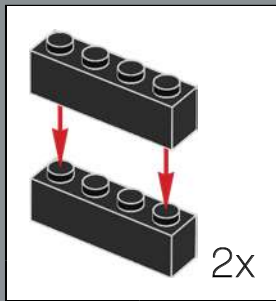

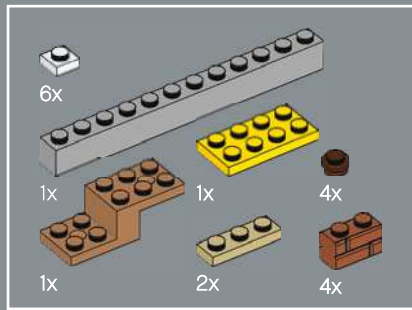

186

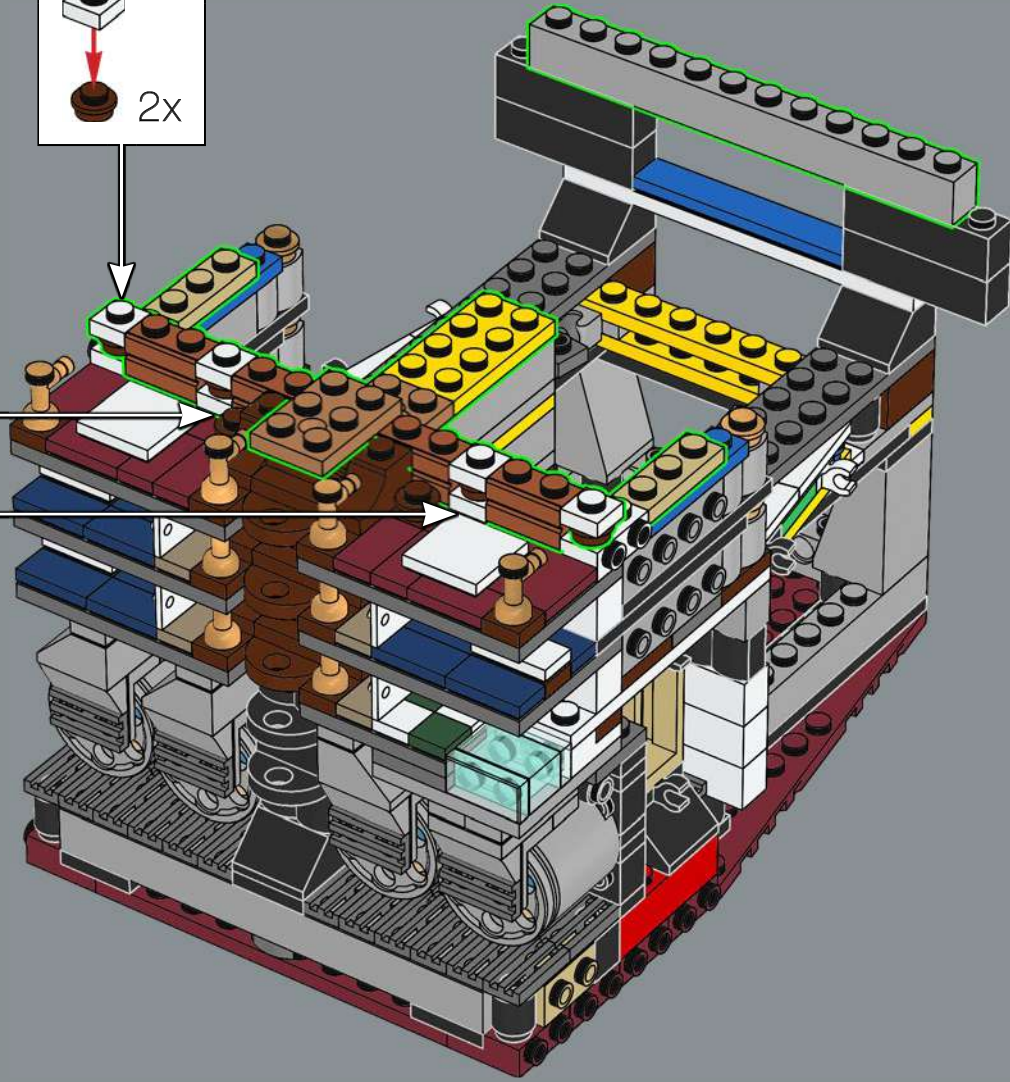
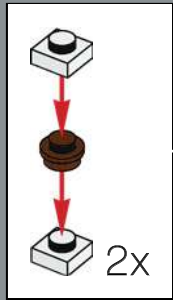
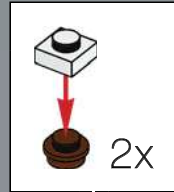

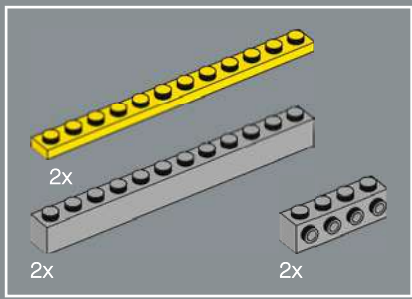

187

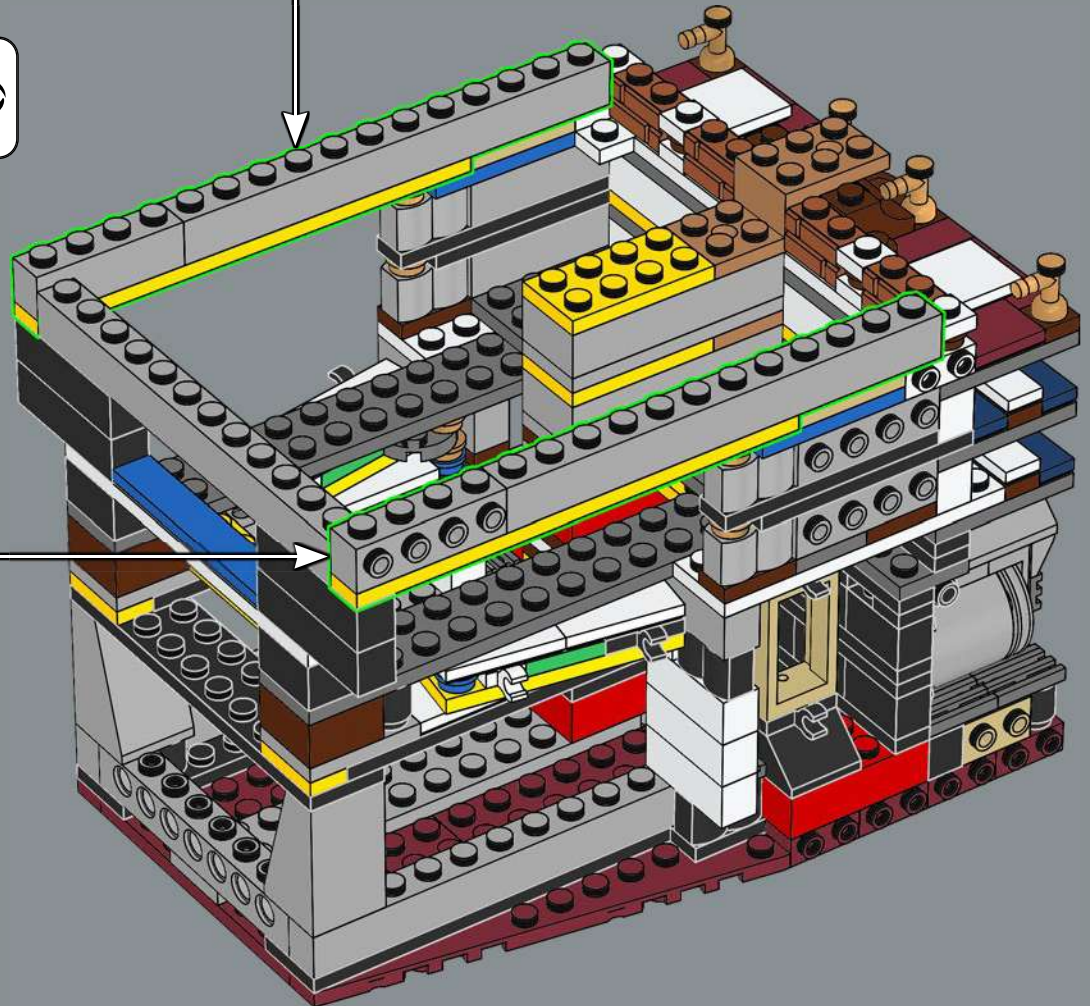
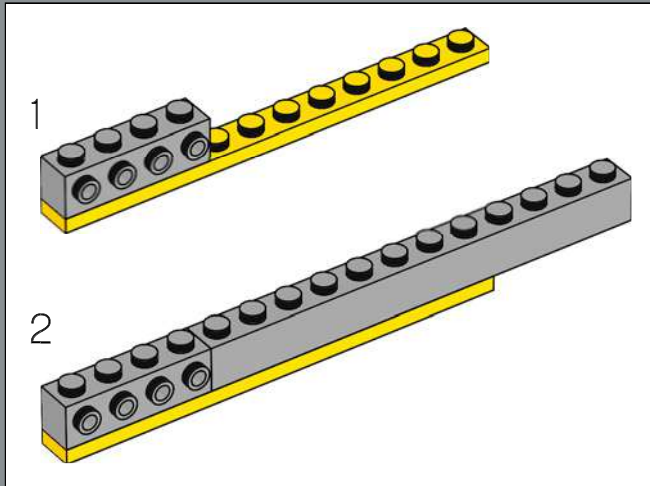
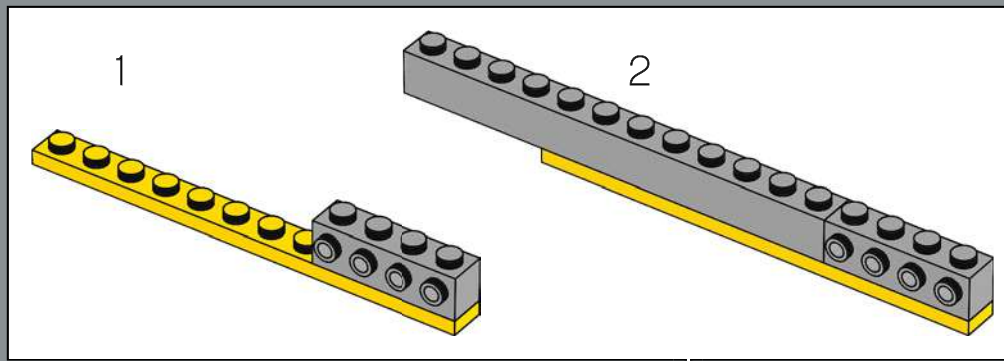

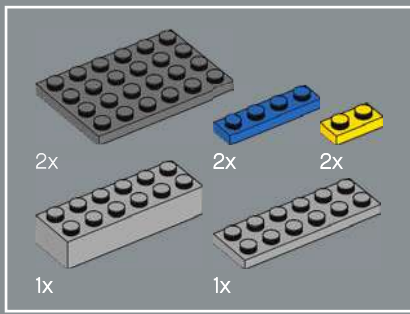

188

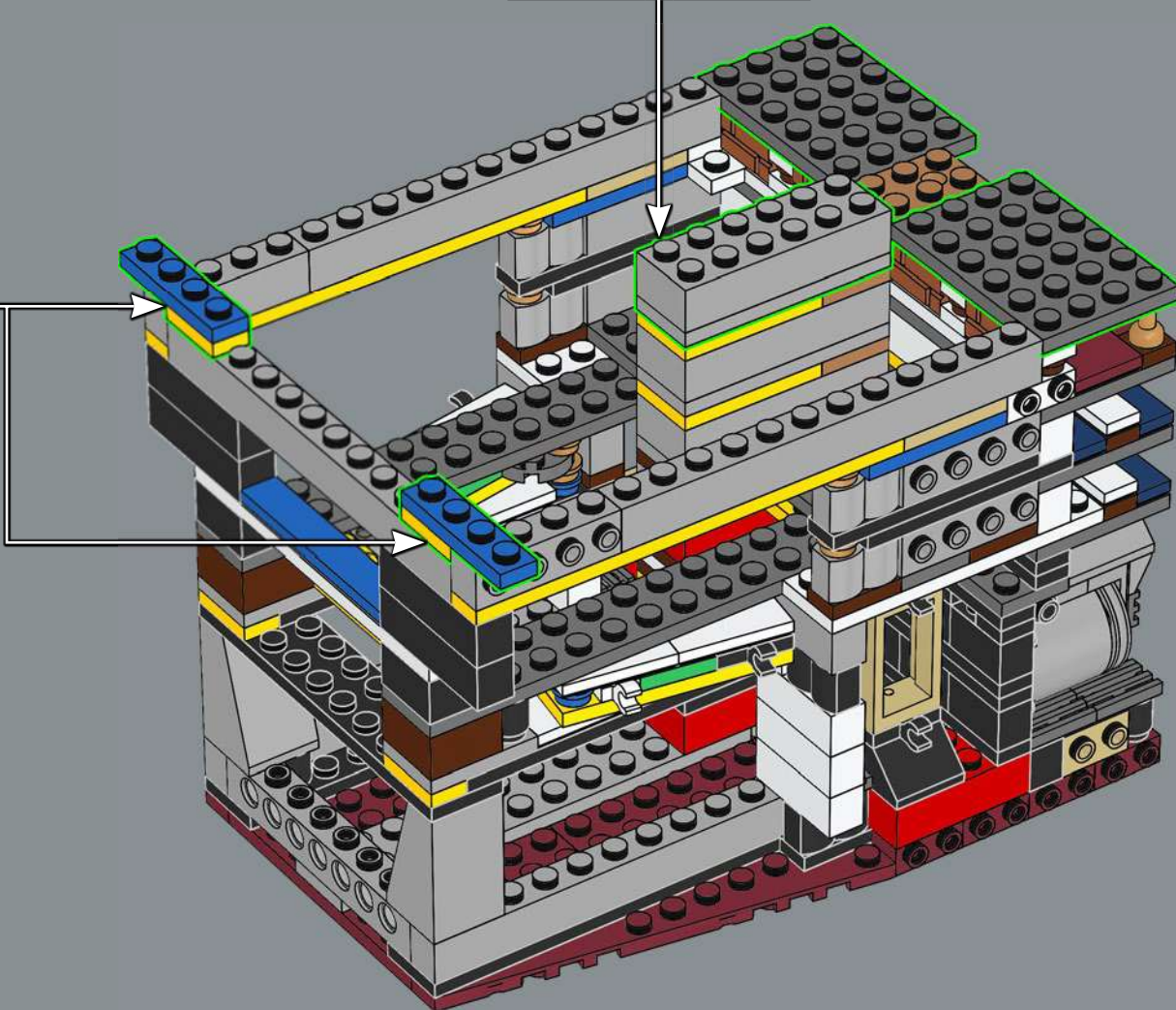
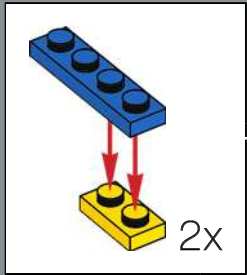
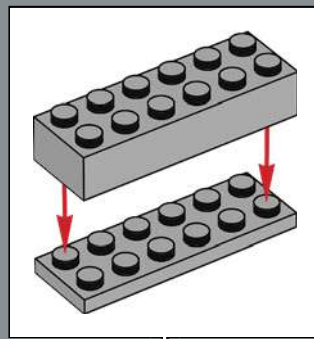

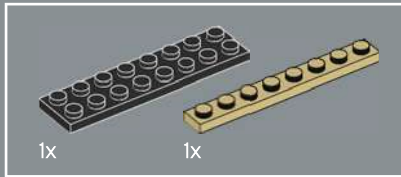
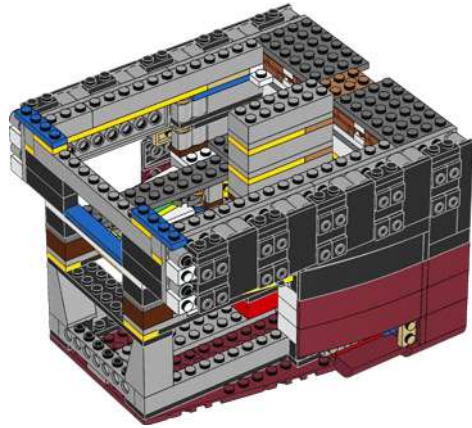
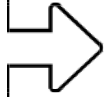

190

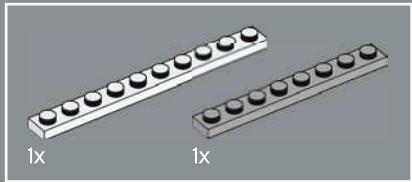
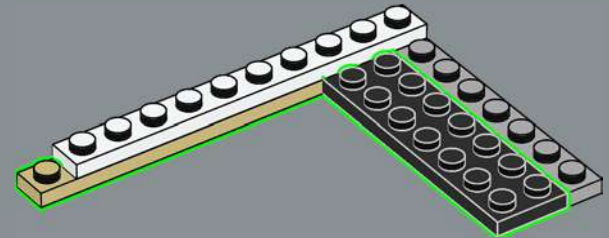

189

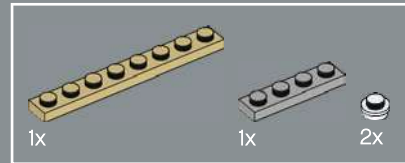
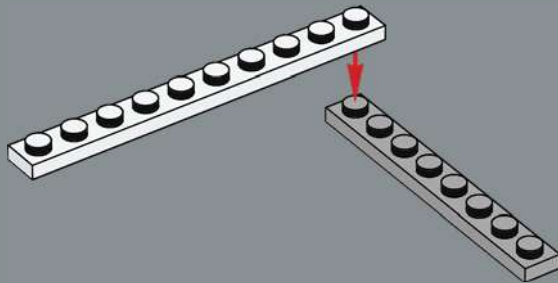

191

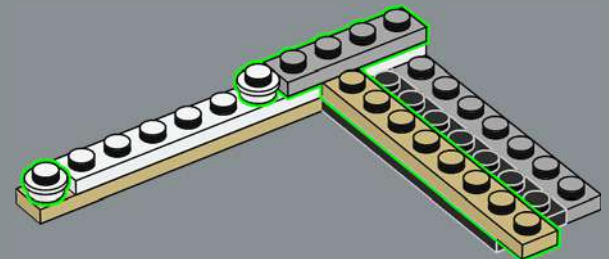

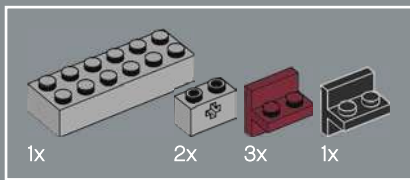

192

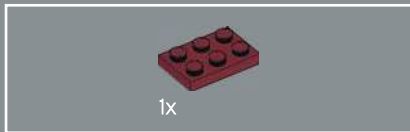
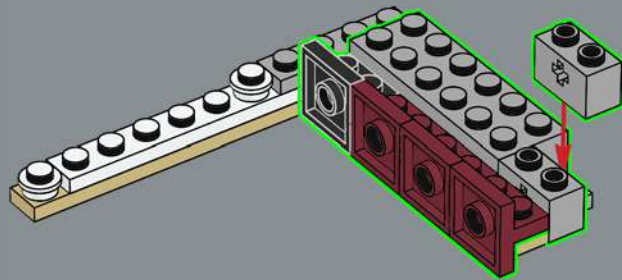

193

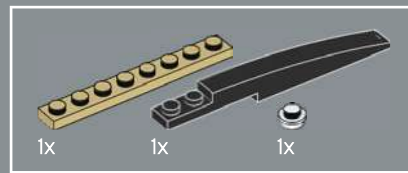
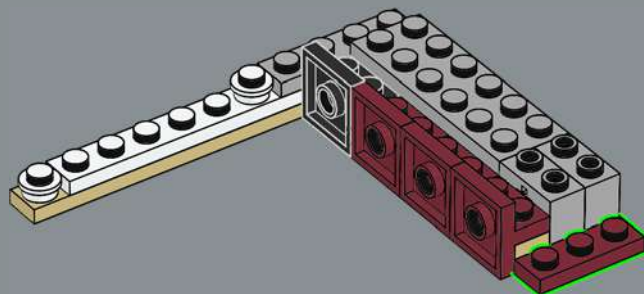

194

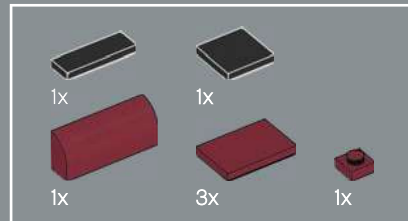
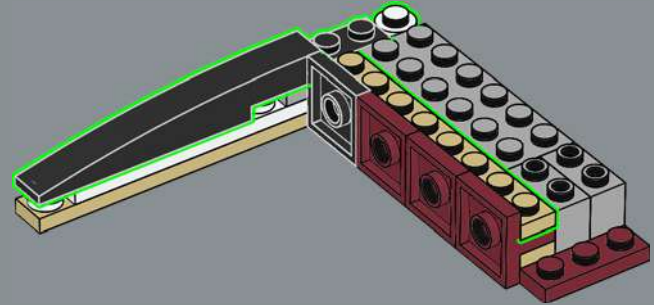

195

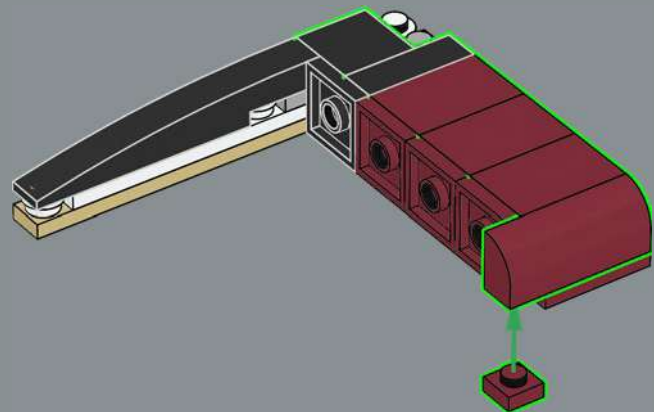

196

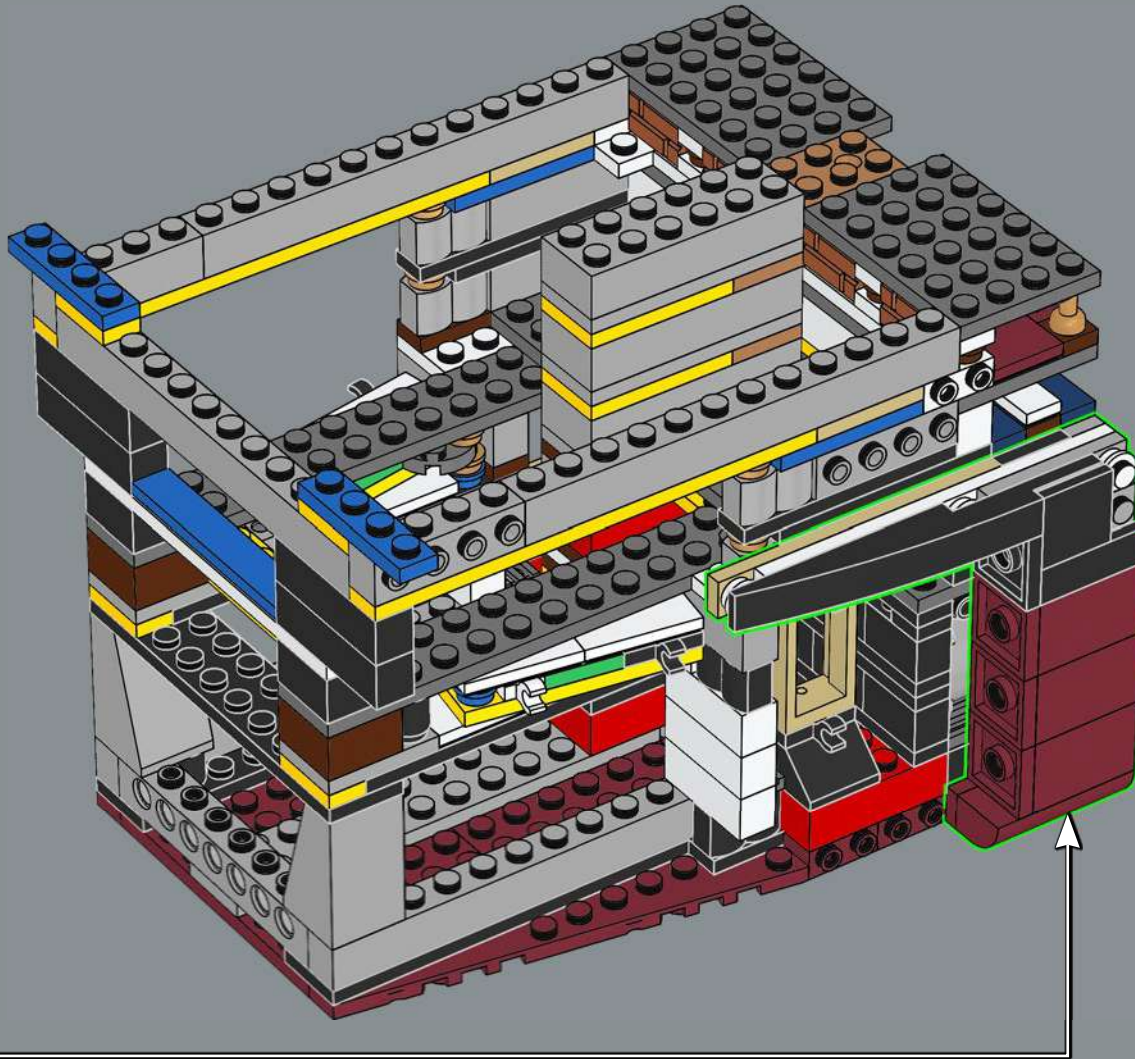

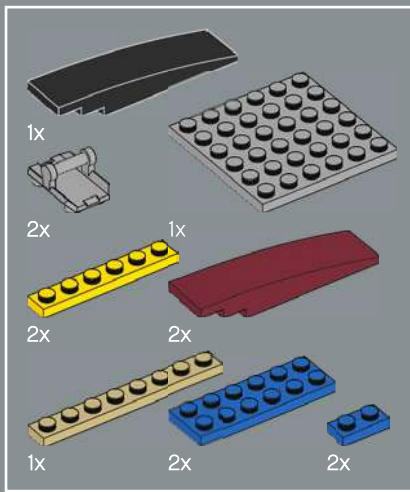

197

1

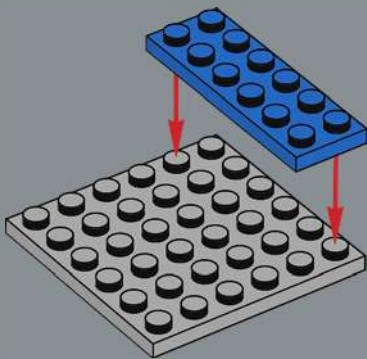

2

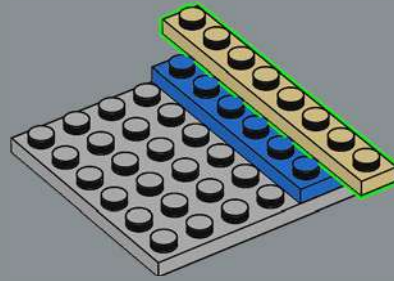

3

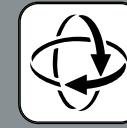
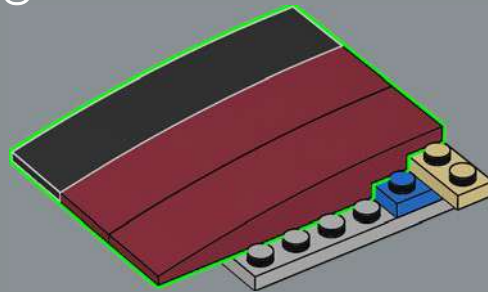

4

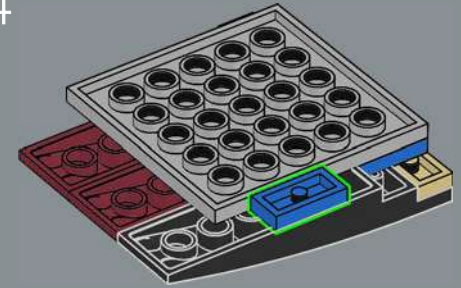

5

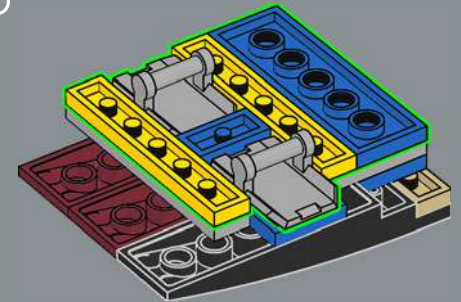

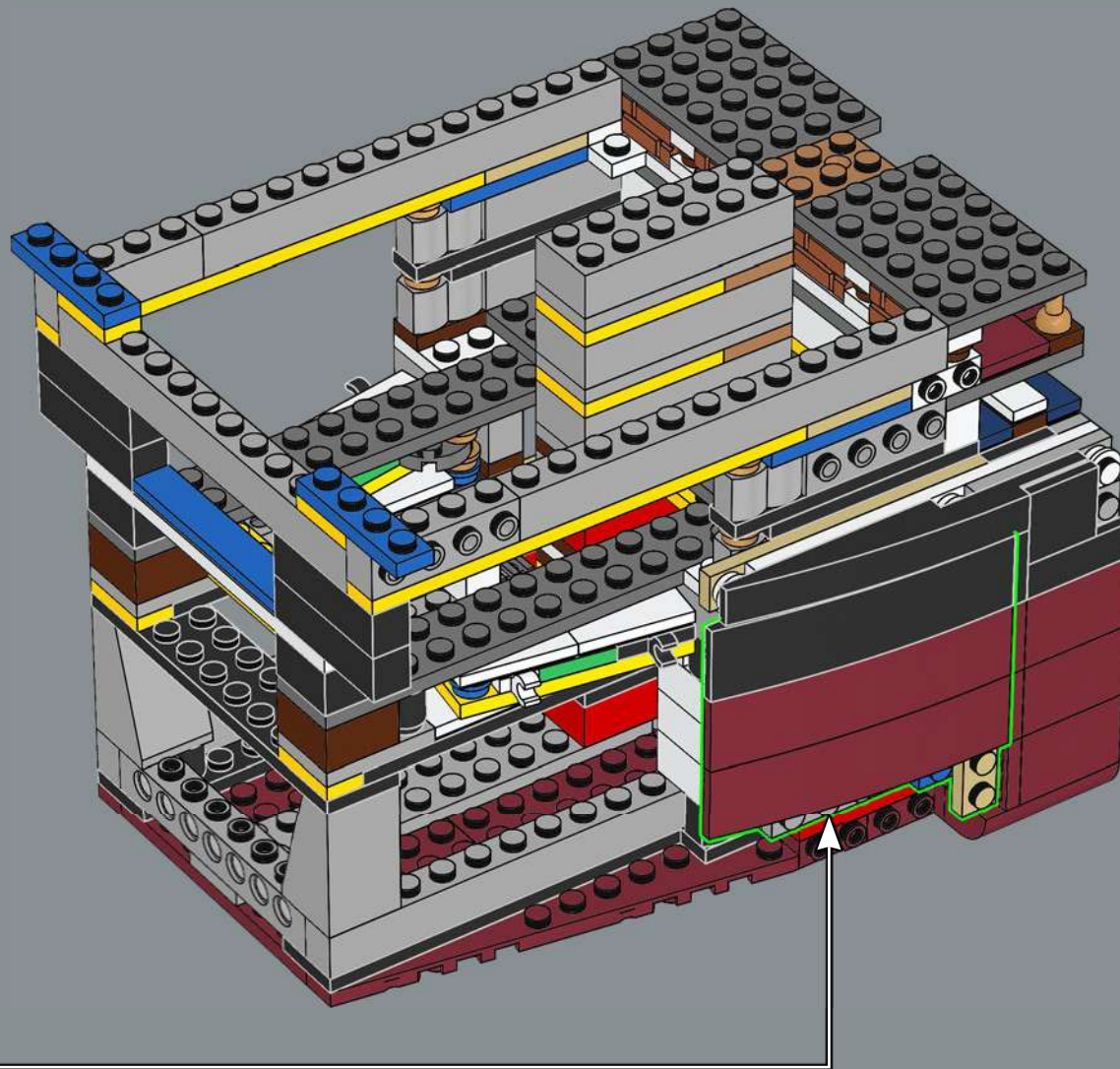

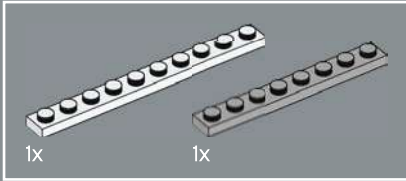
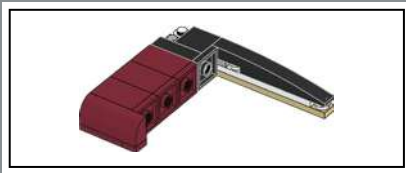

198

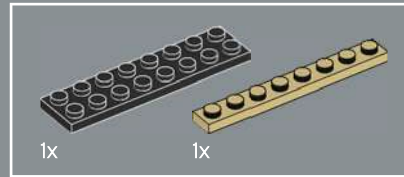
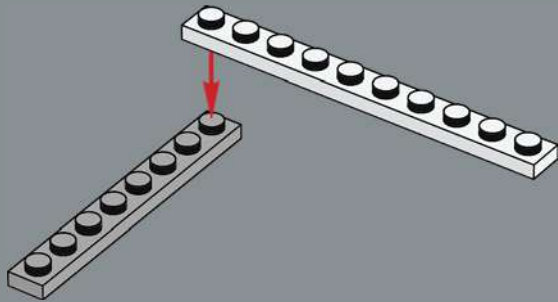

199

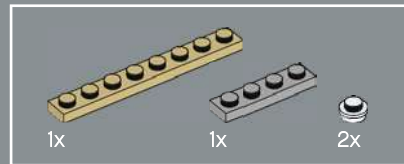
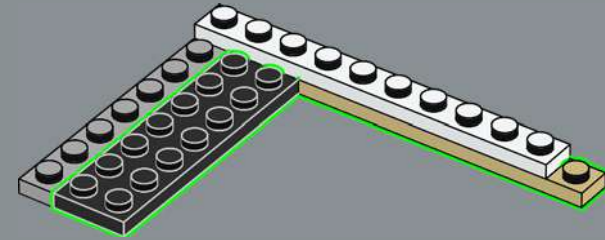

200

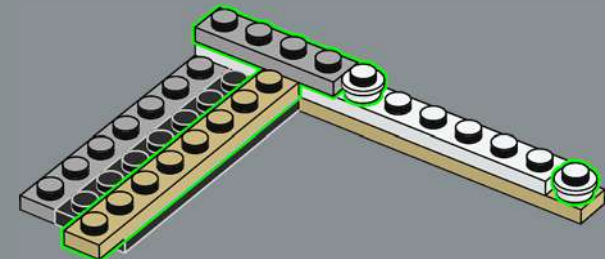

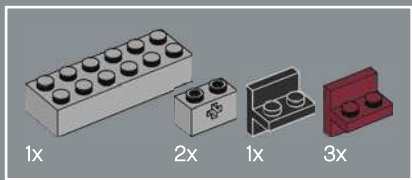

201

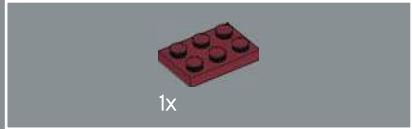
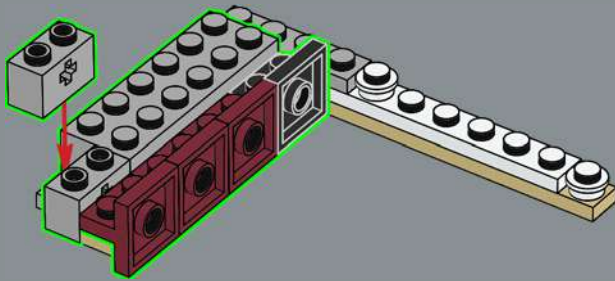

202

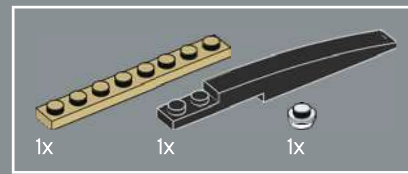
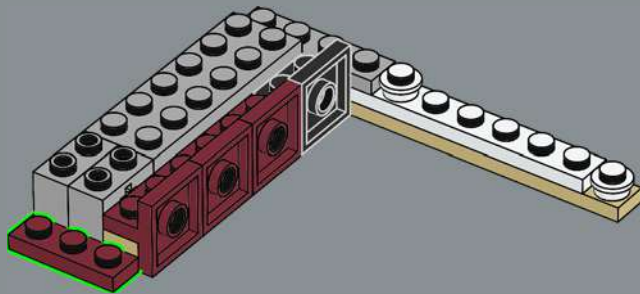

203

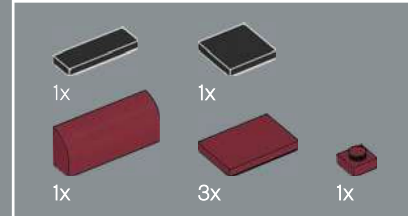
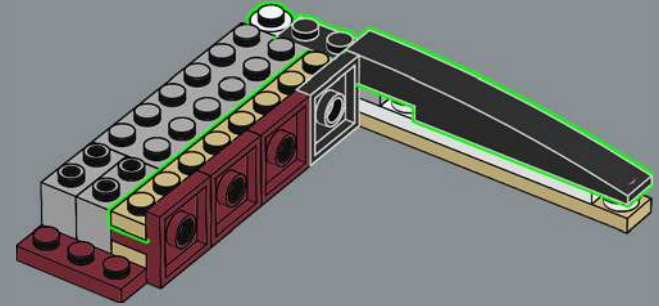

204

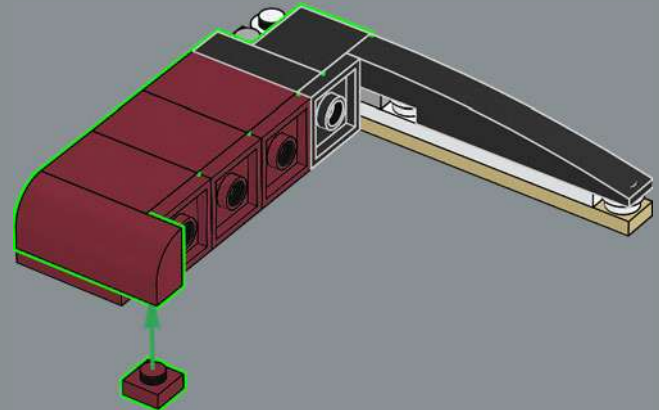

205

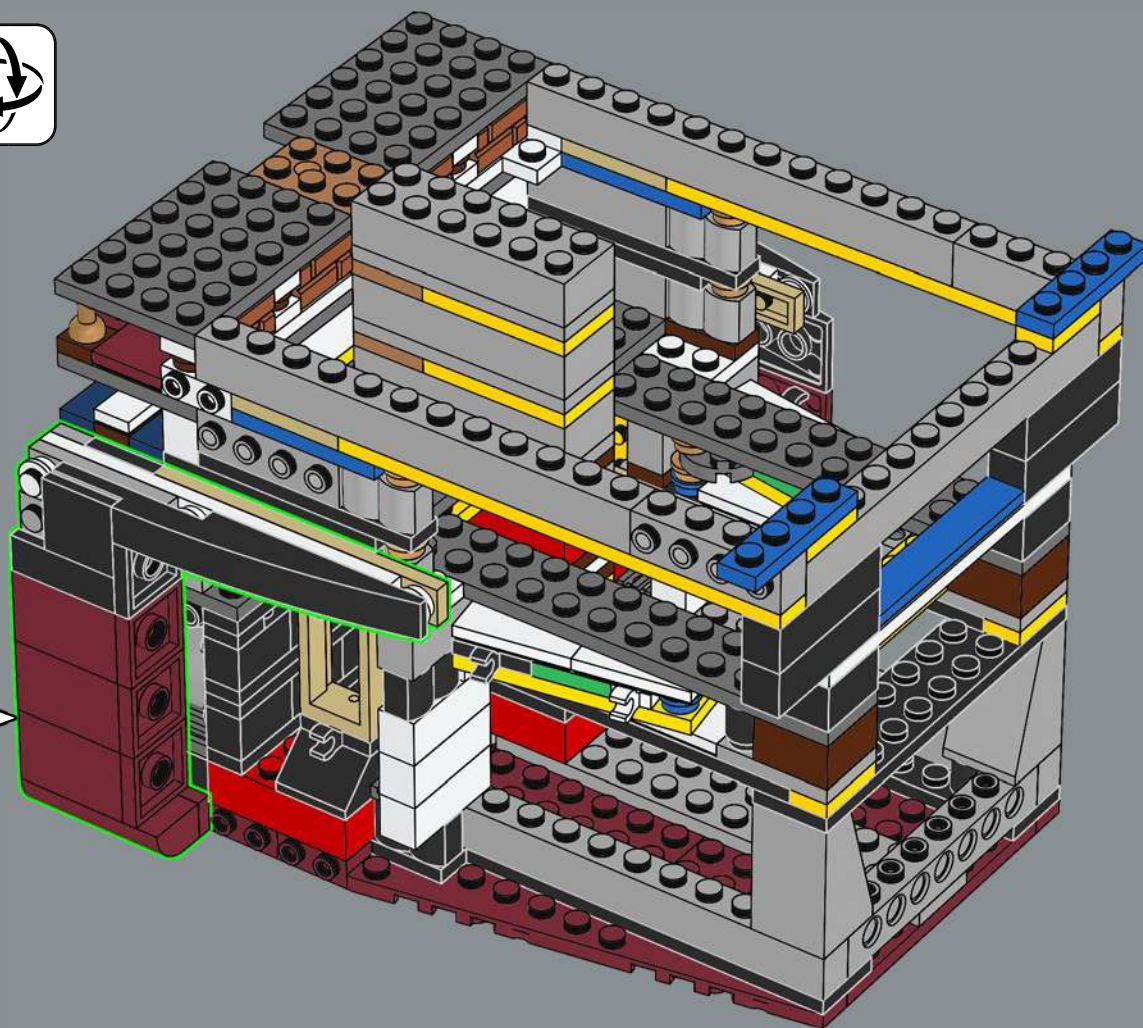

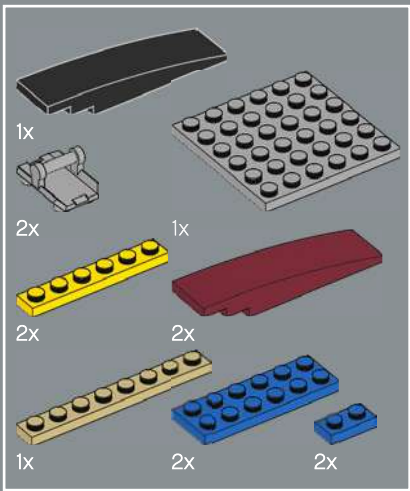

206

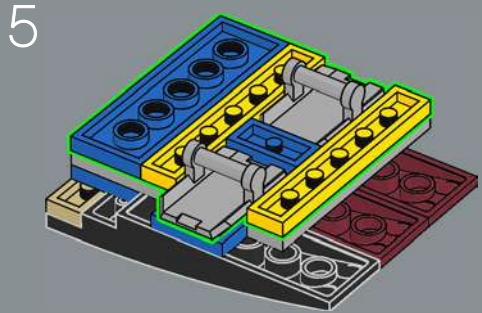
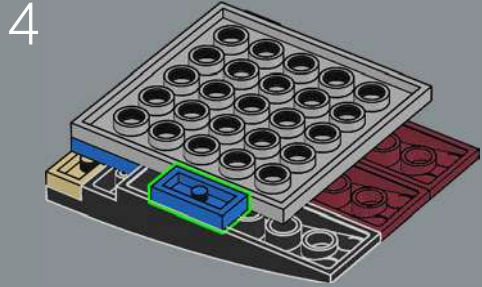
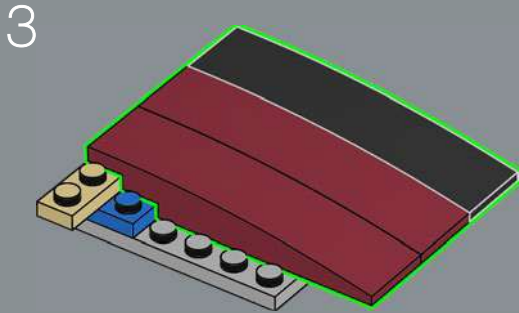
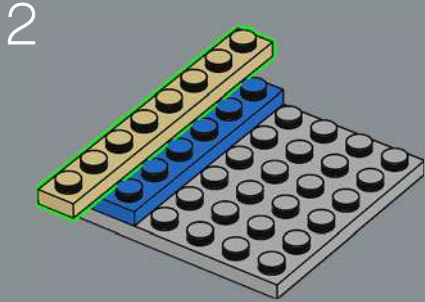
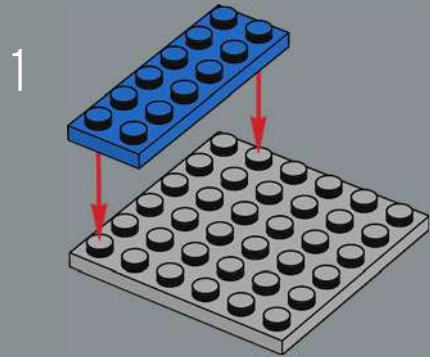

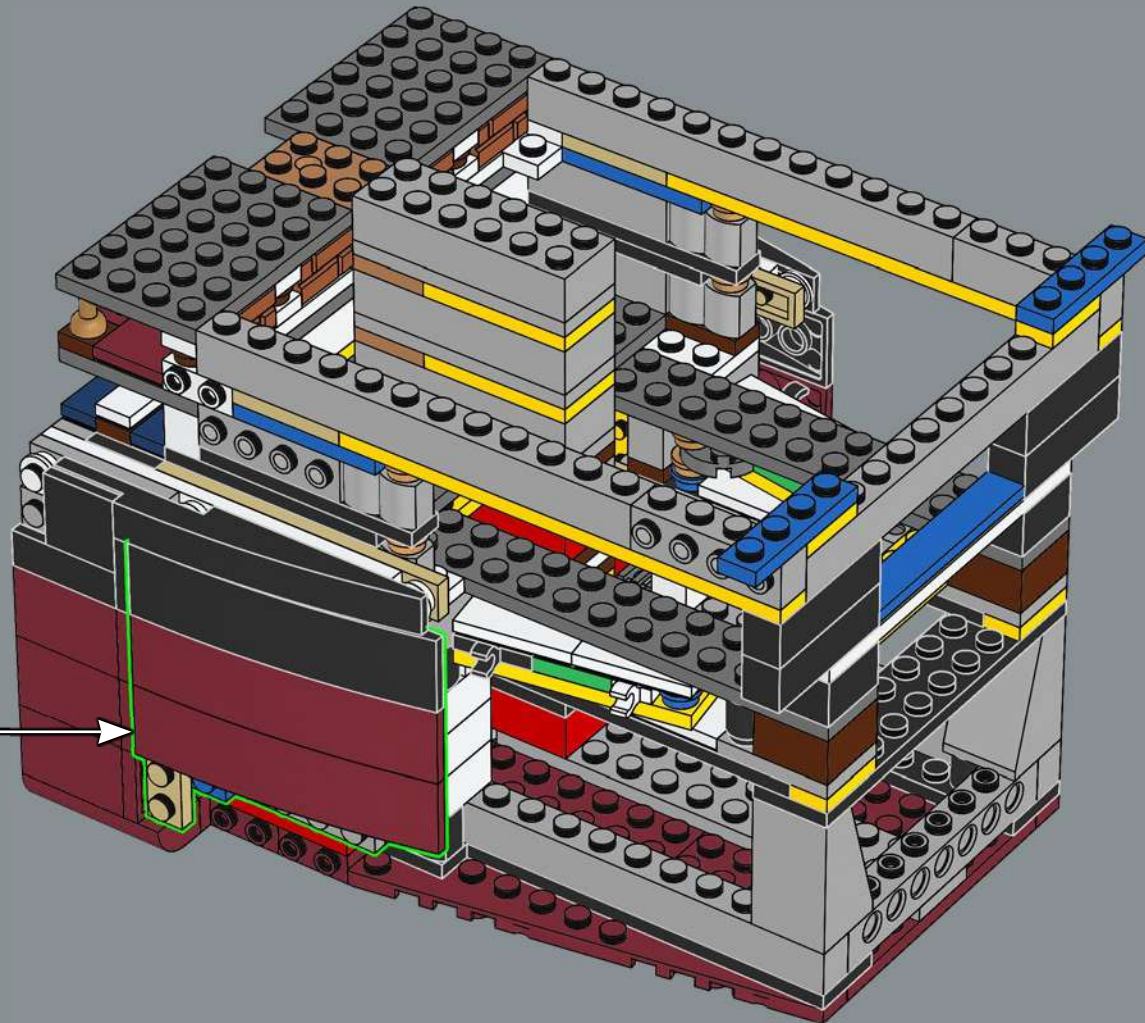

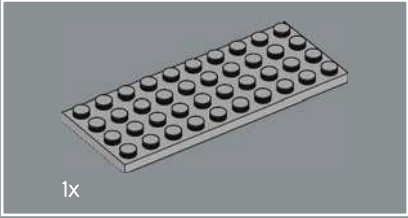
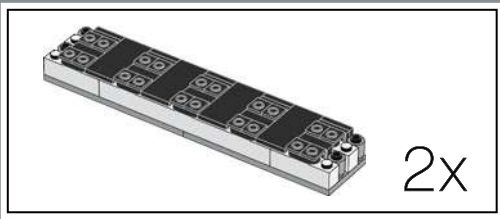

207

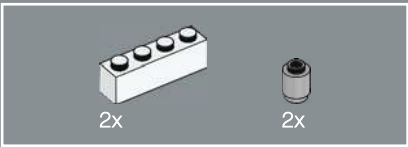
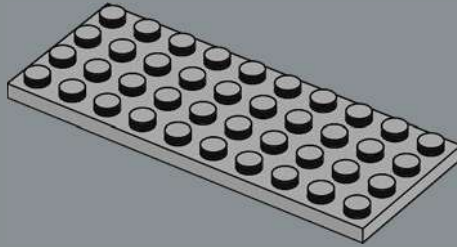

208

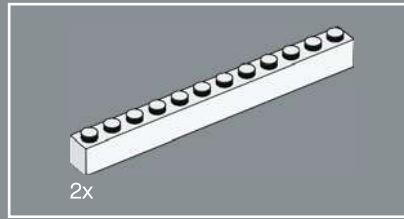
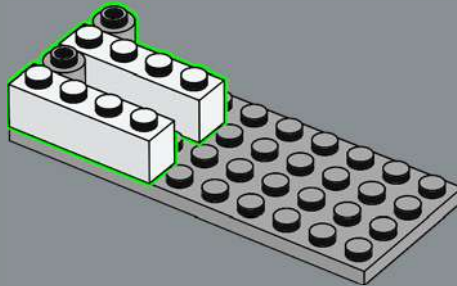

209

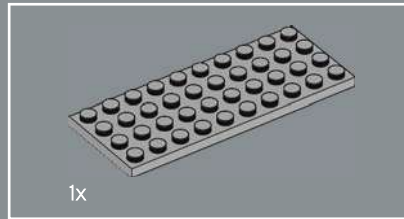
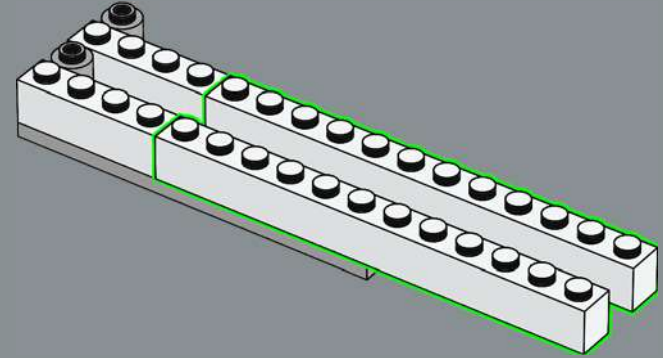

210

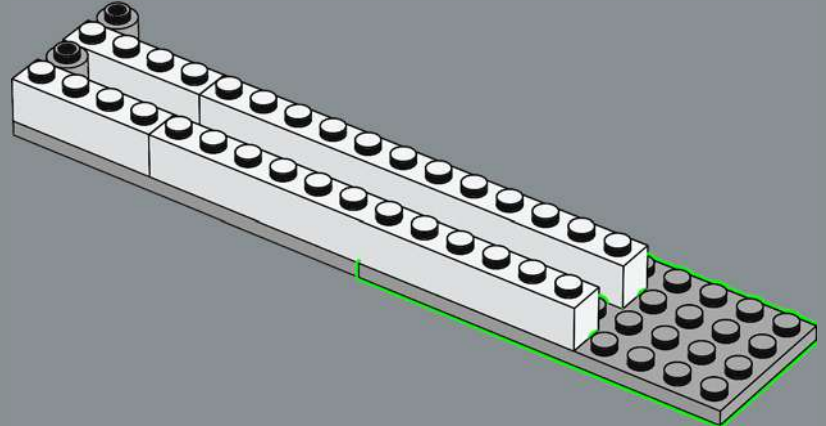

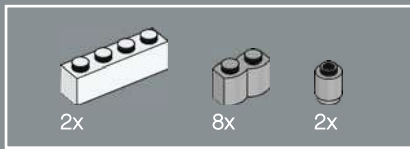

211

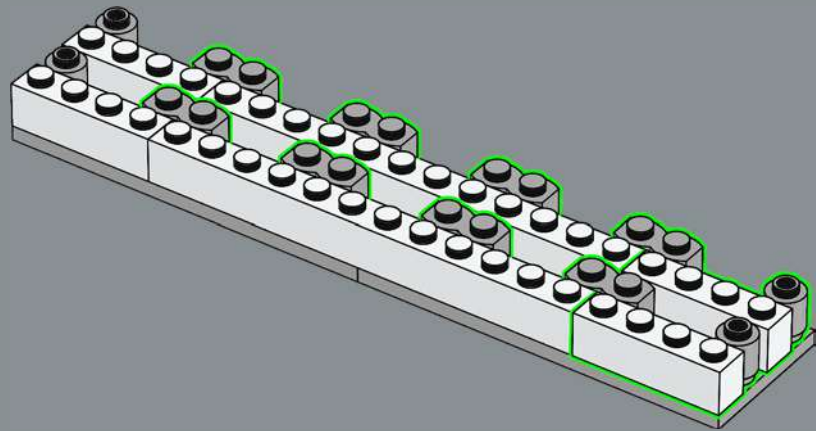

212

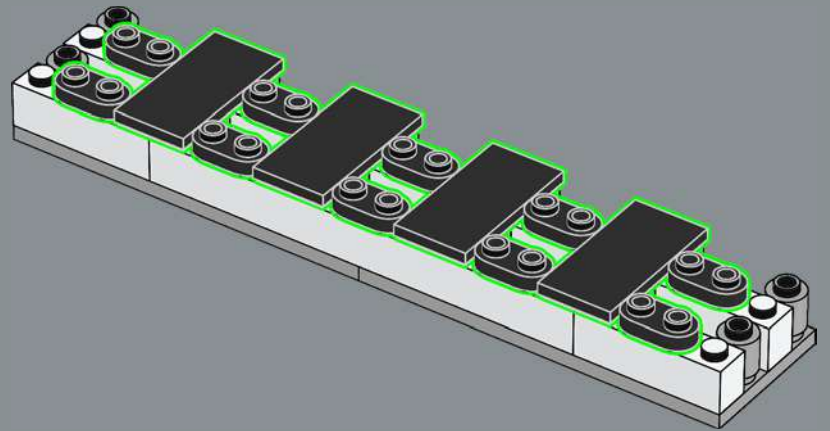



213

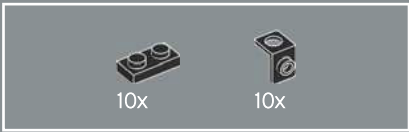
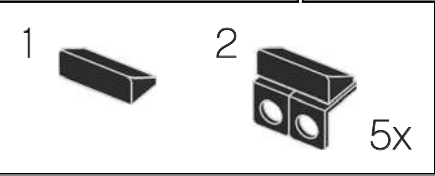
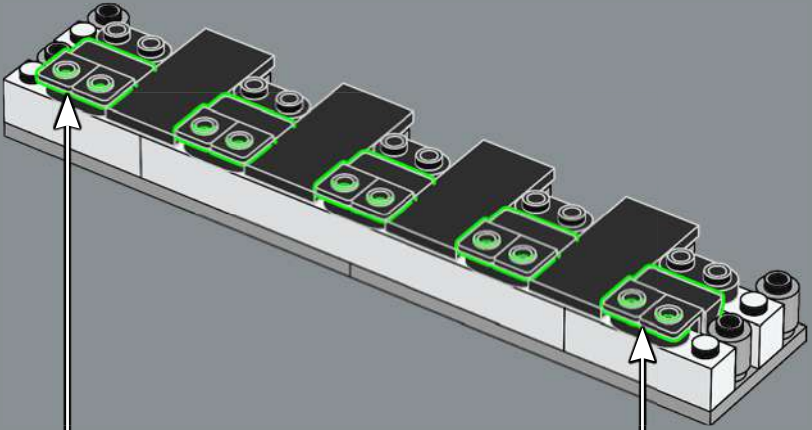

214

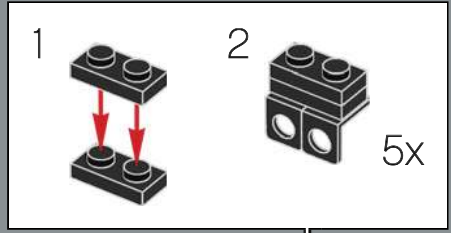
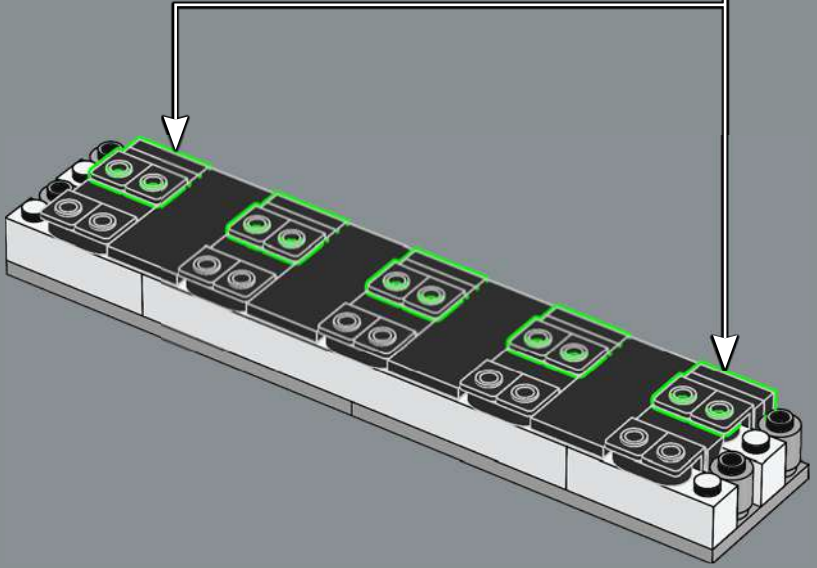

2x

215

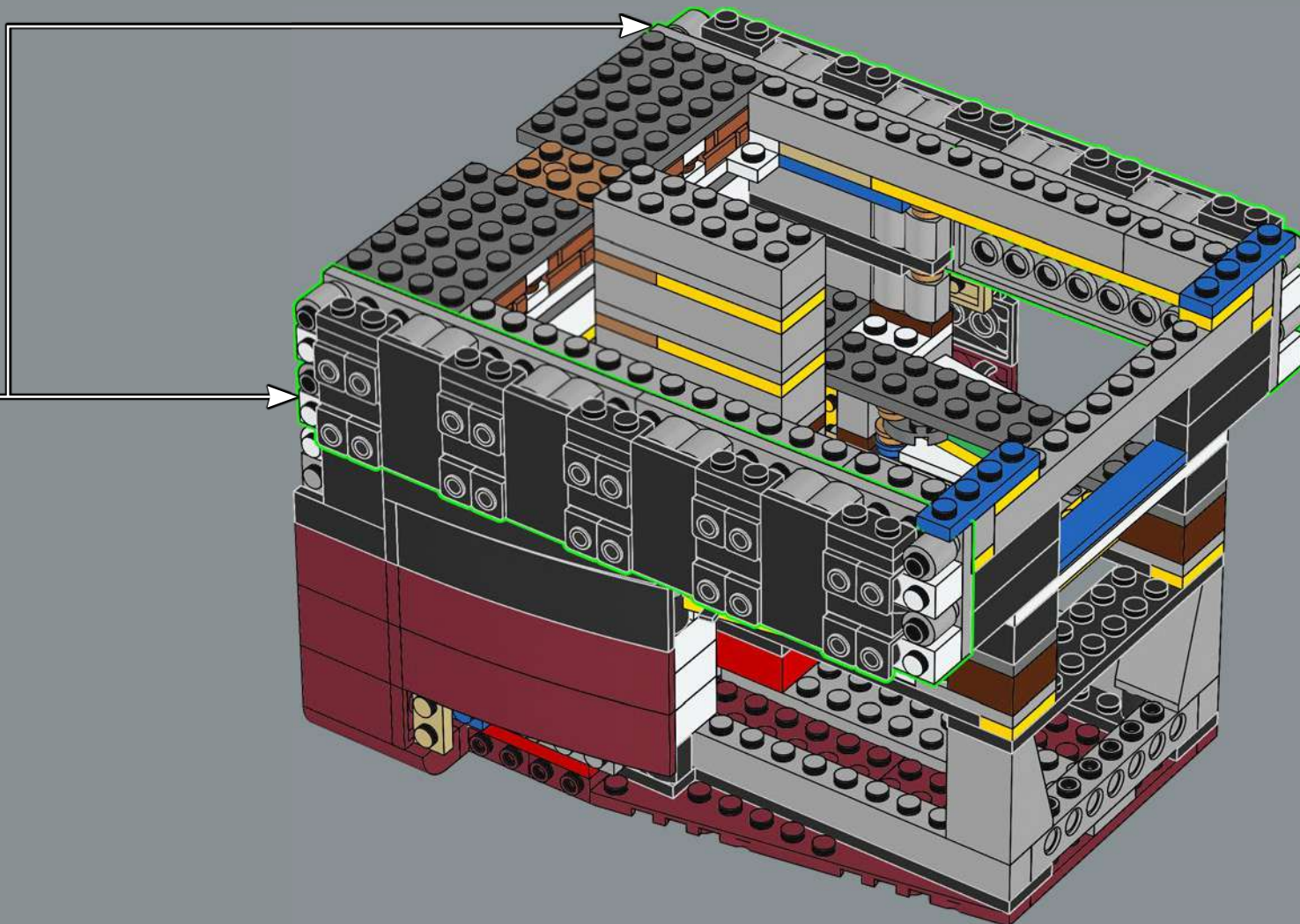

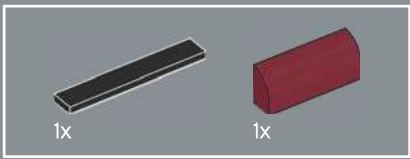

216

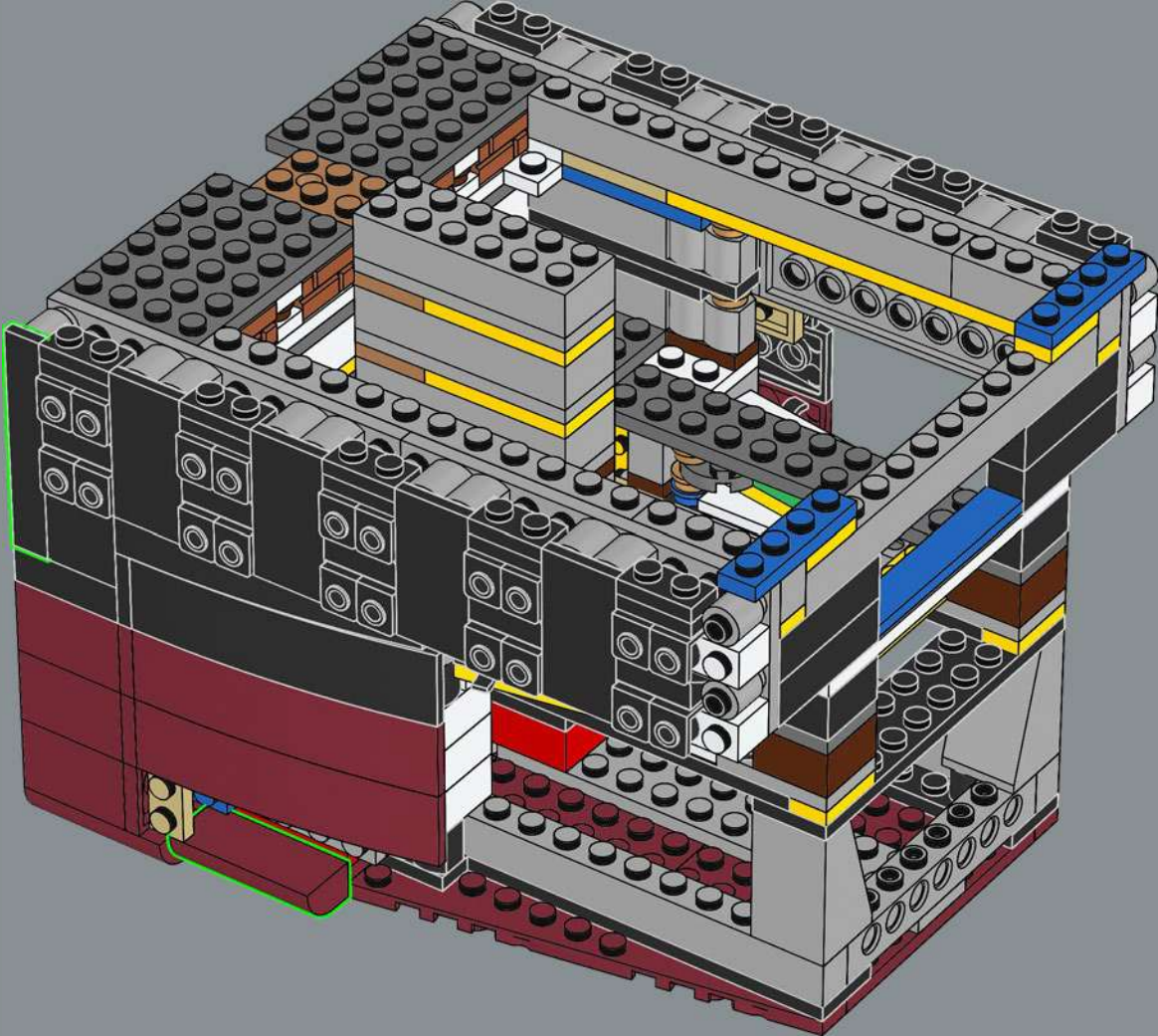

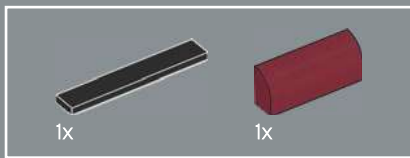

217

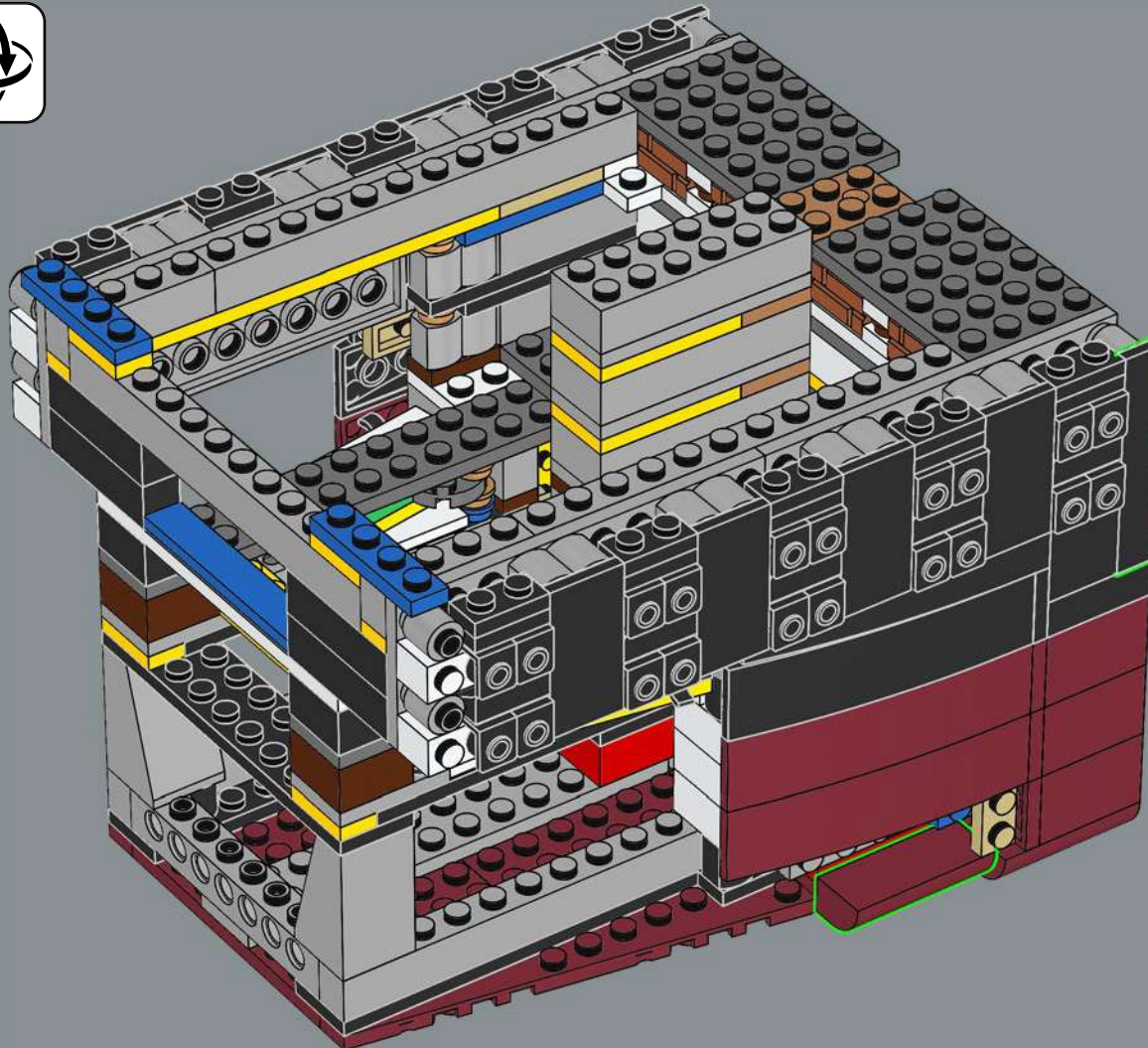

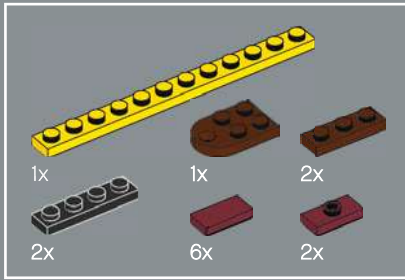
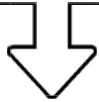

218

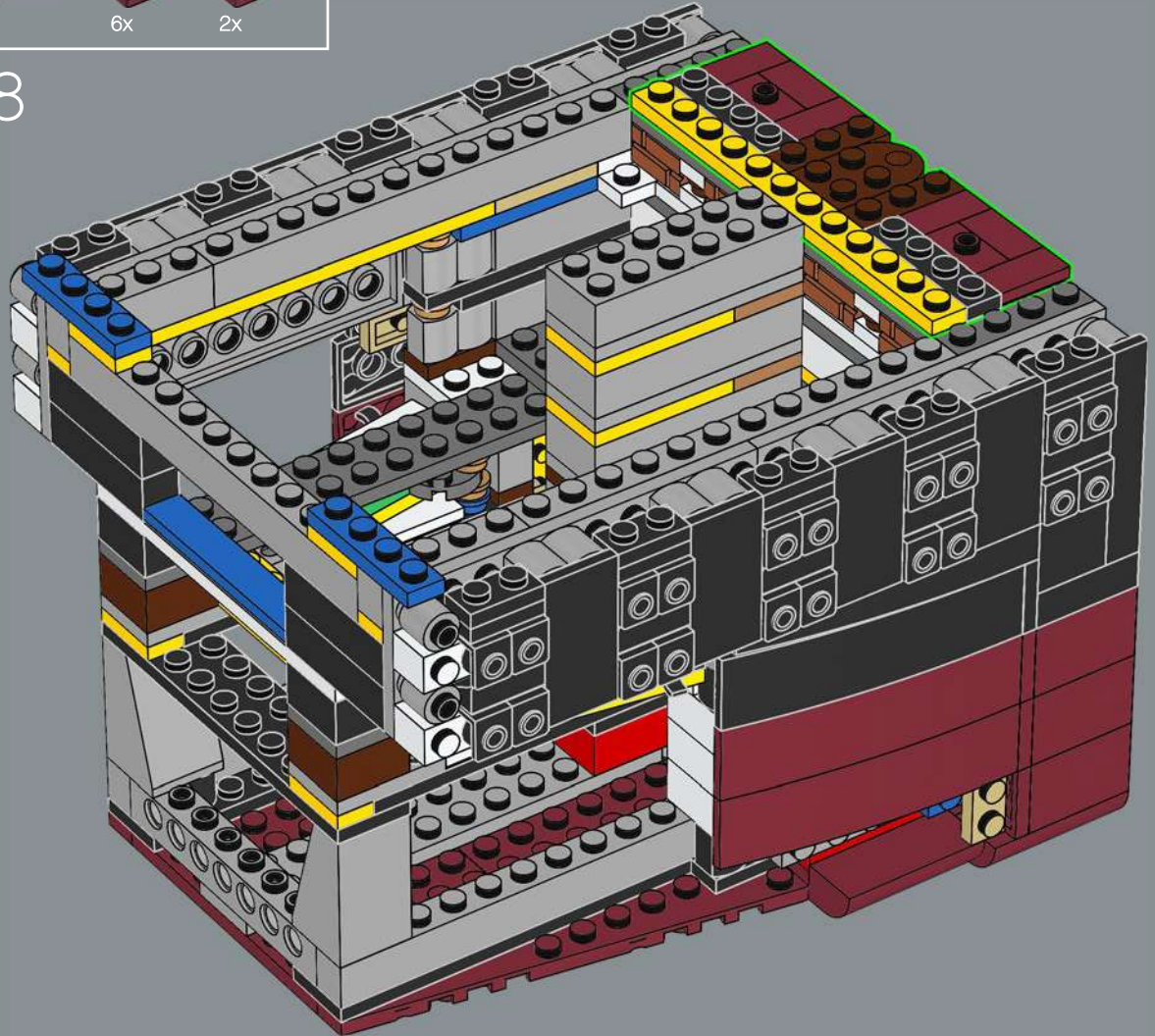



219

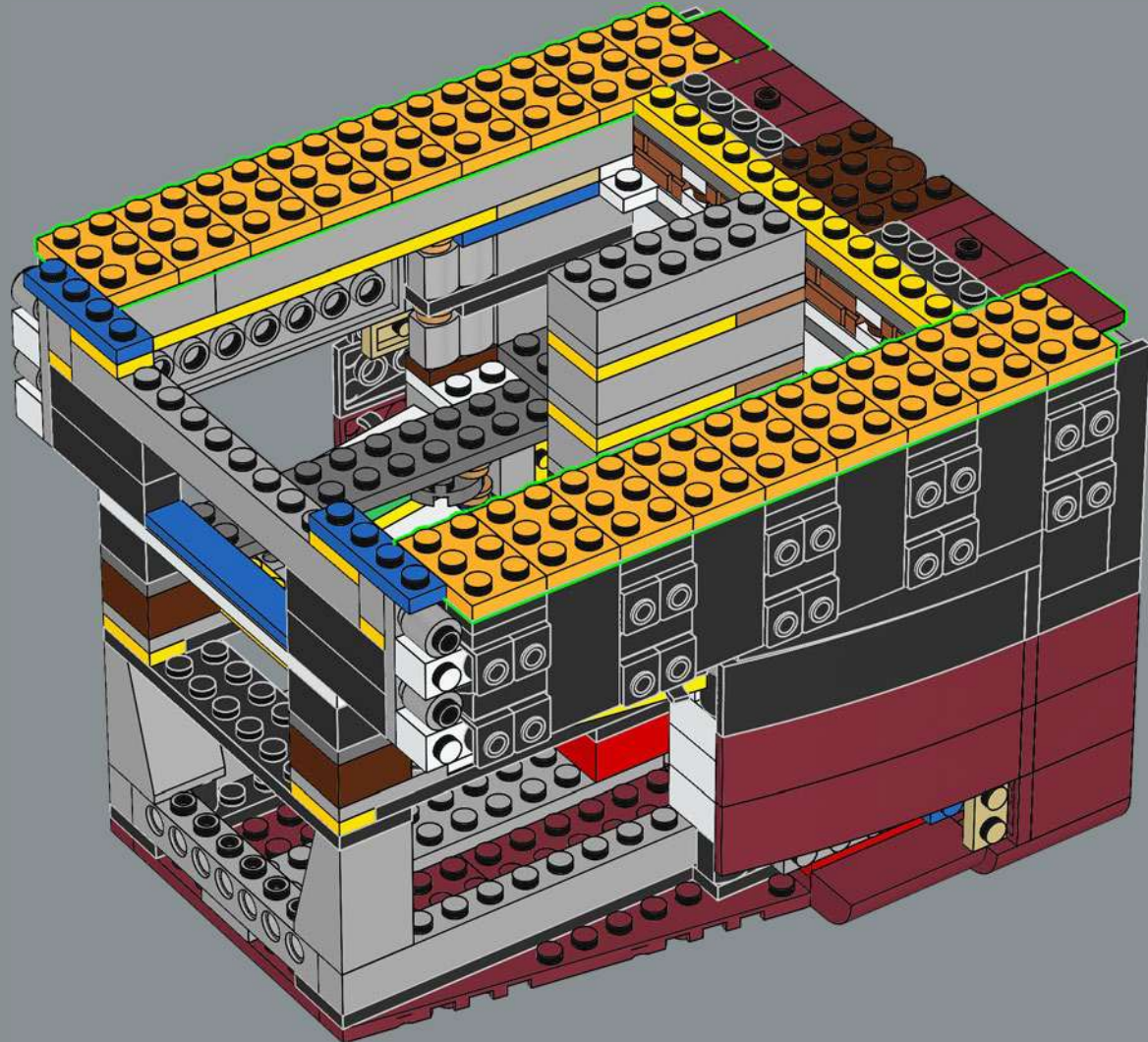

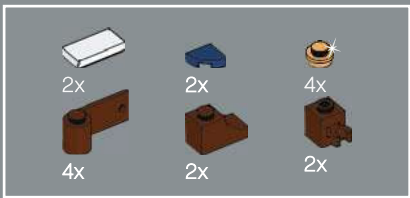

220

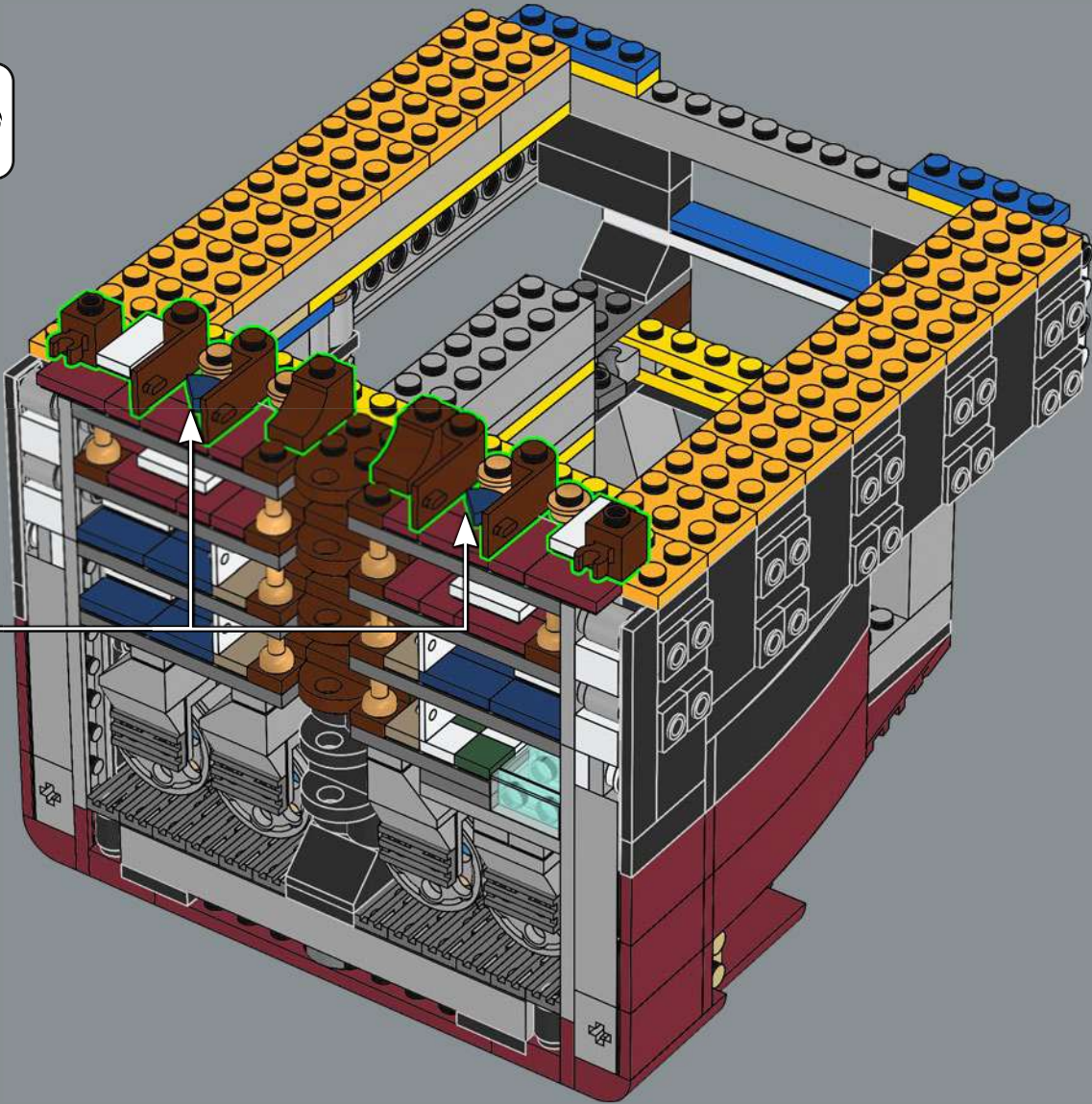

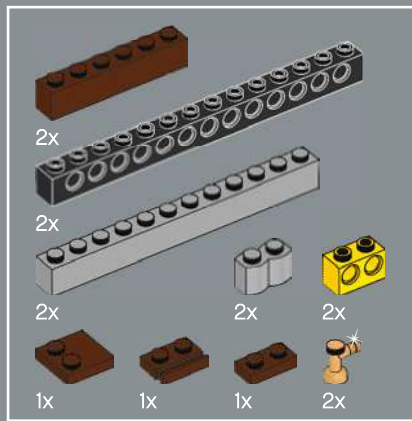

221

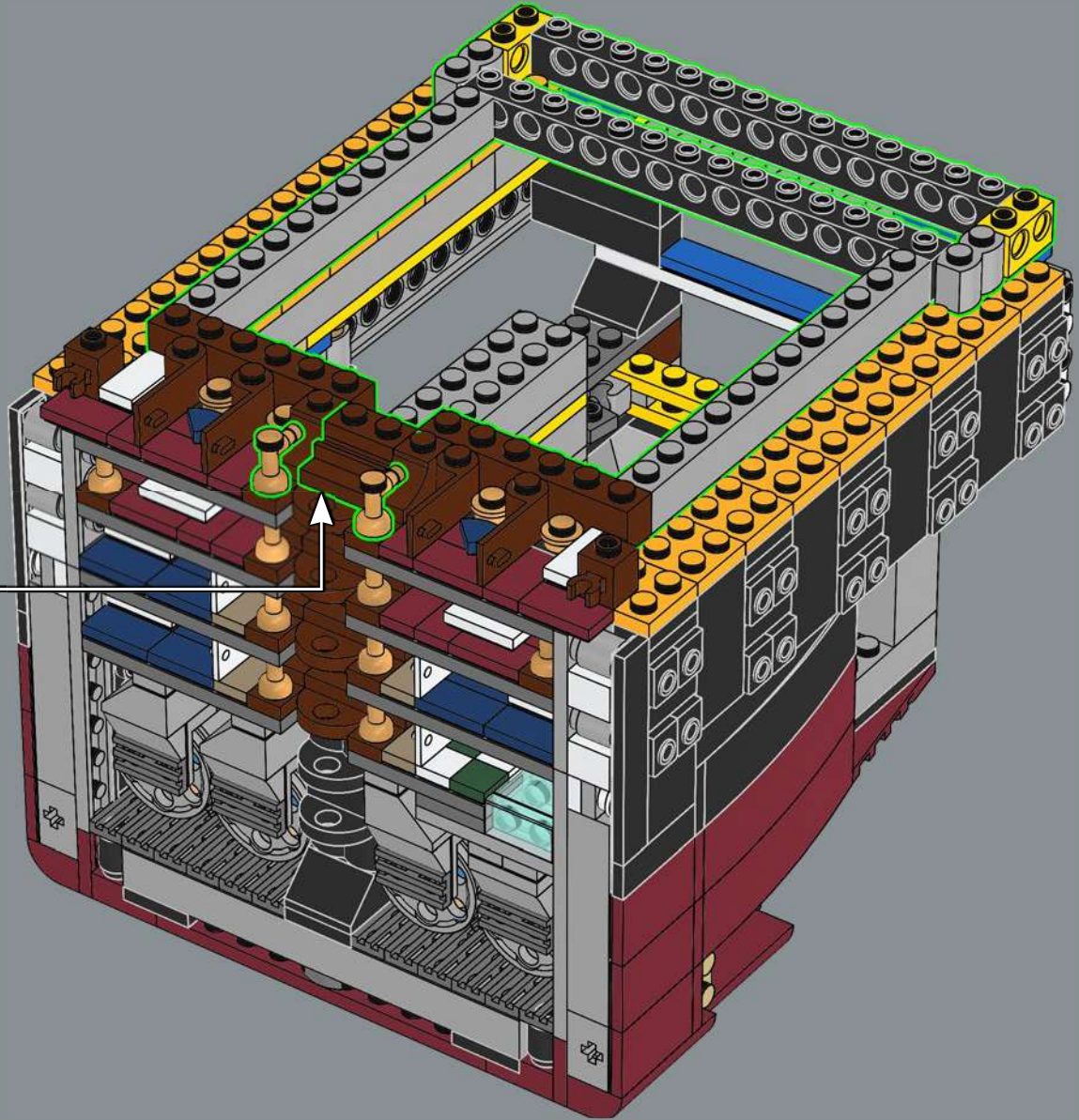
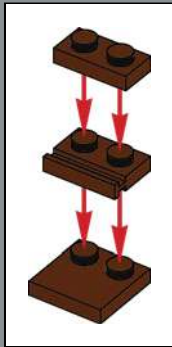

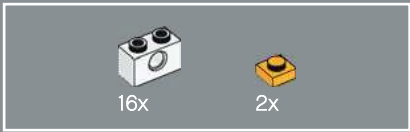

222

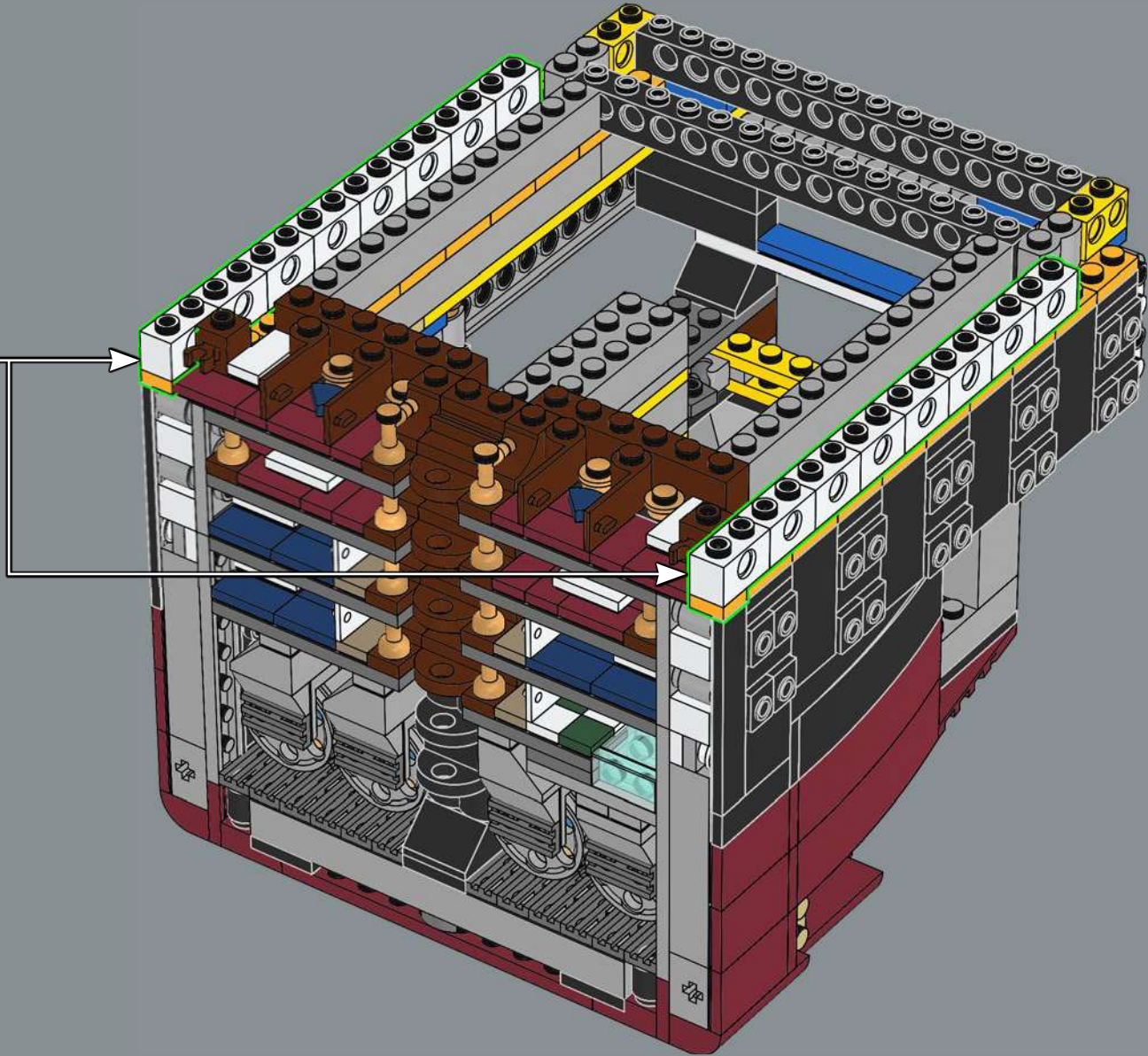
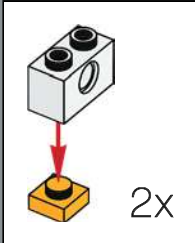

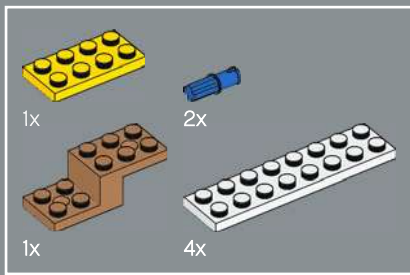

223

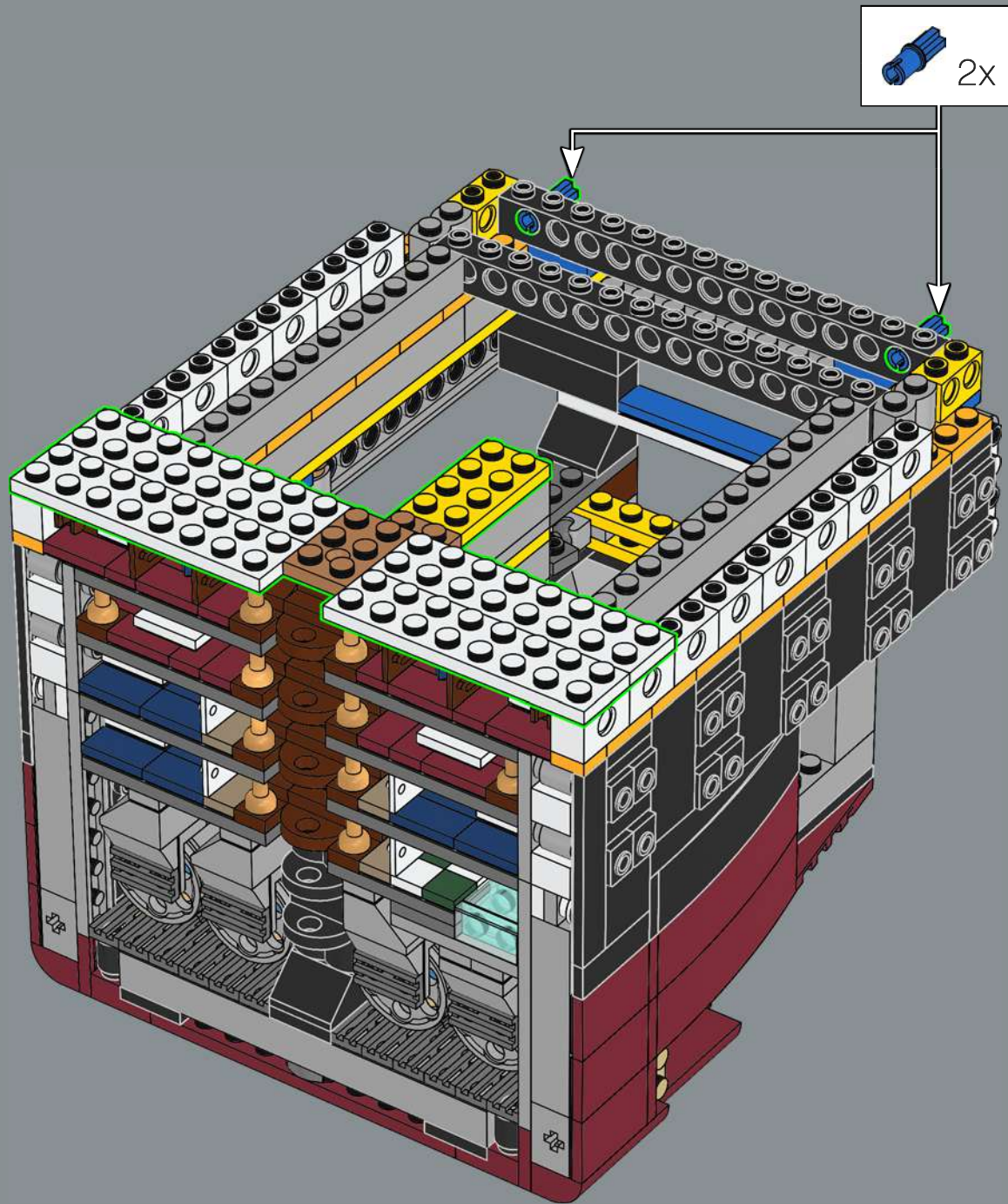

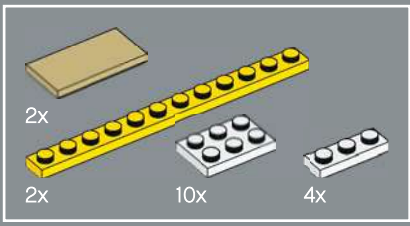

224

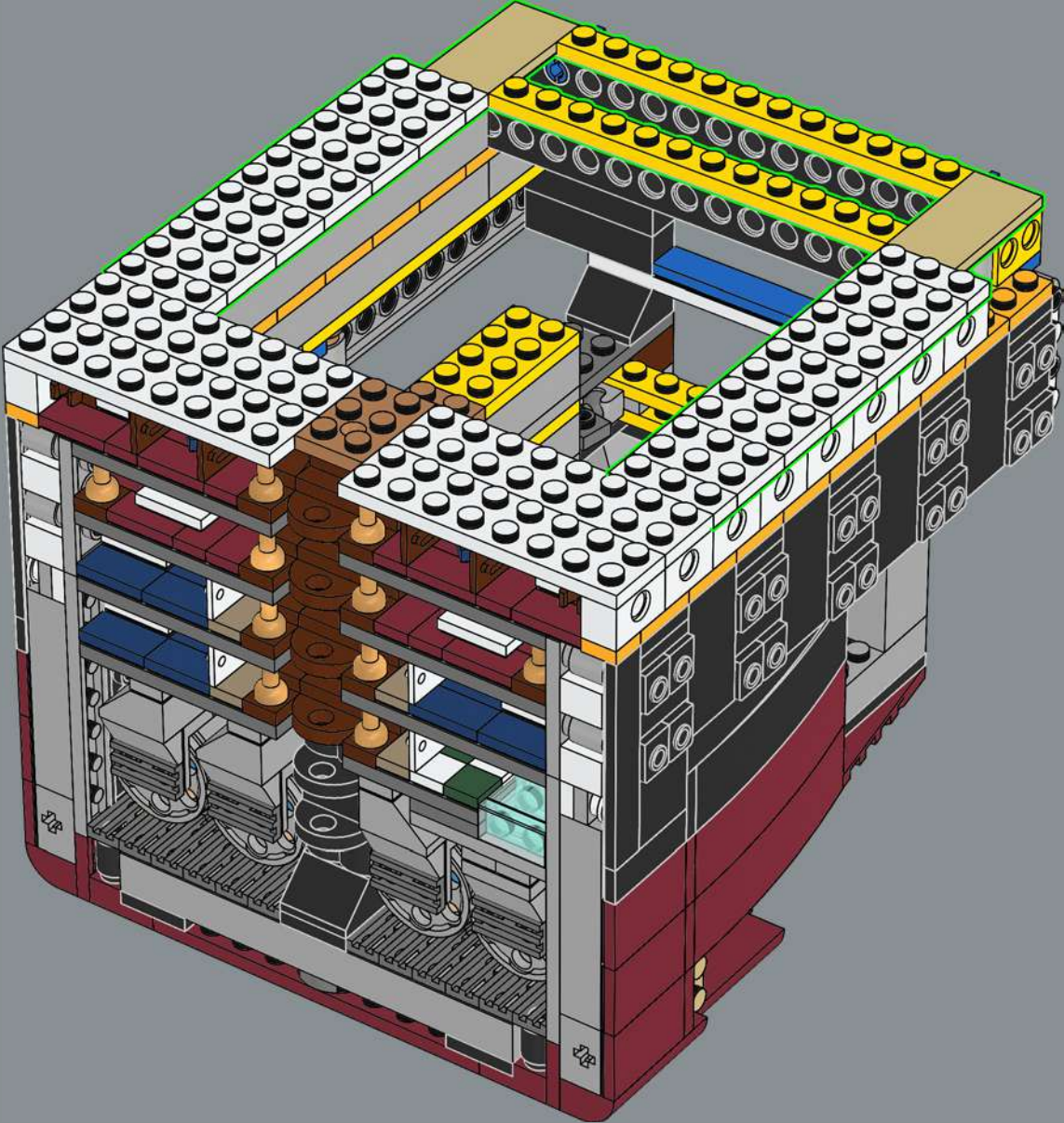

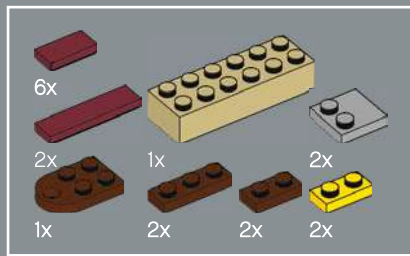

225

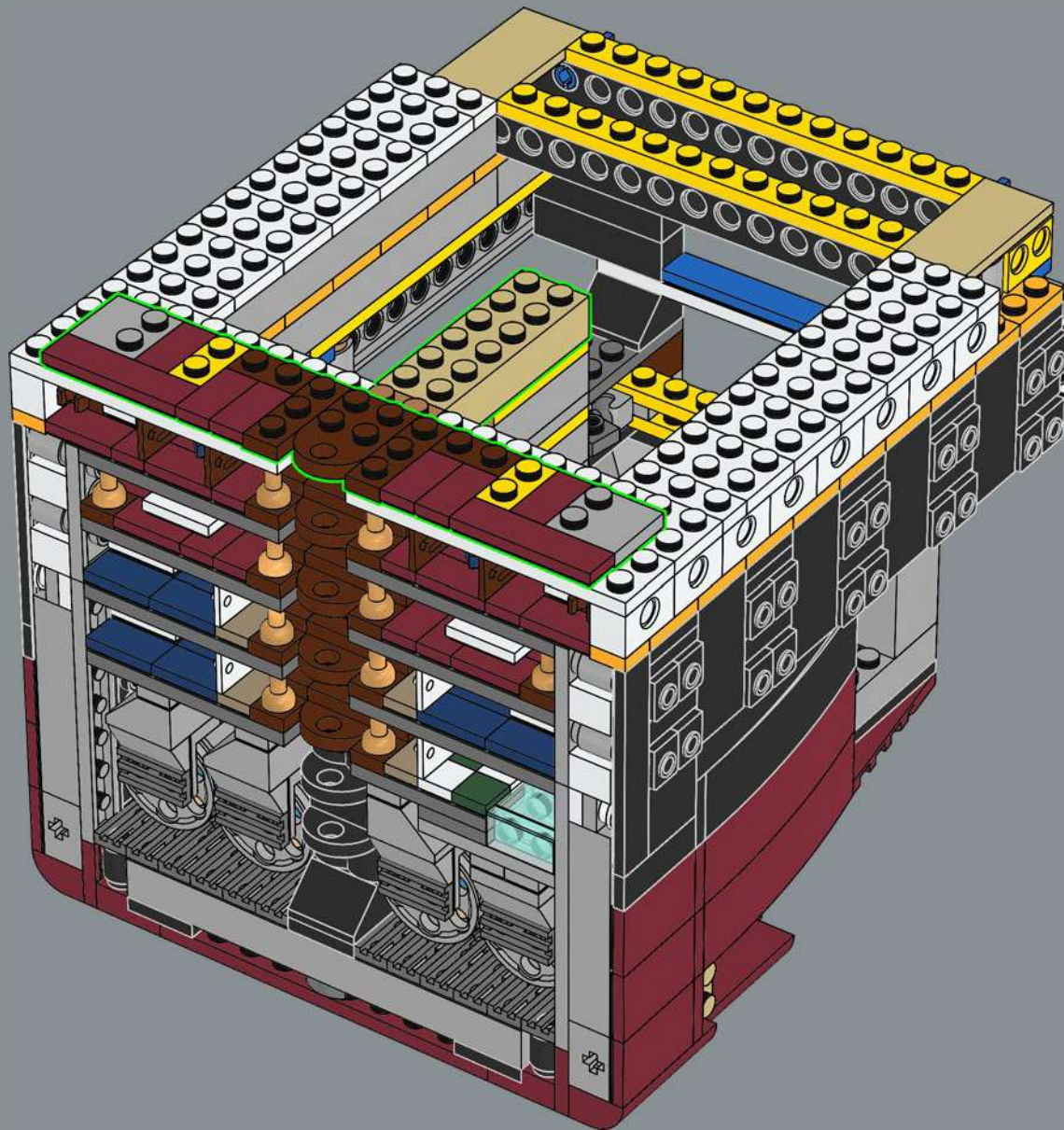

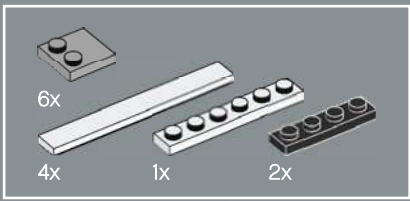

226

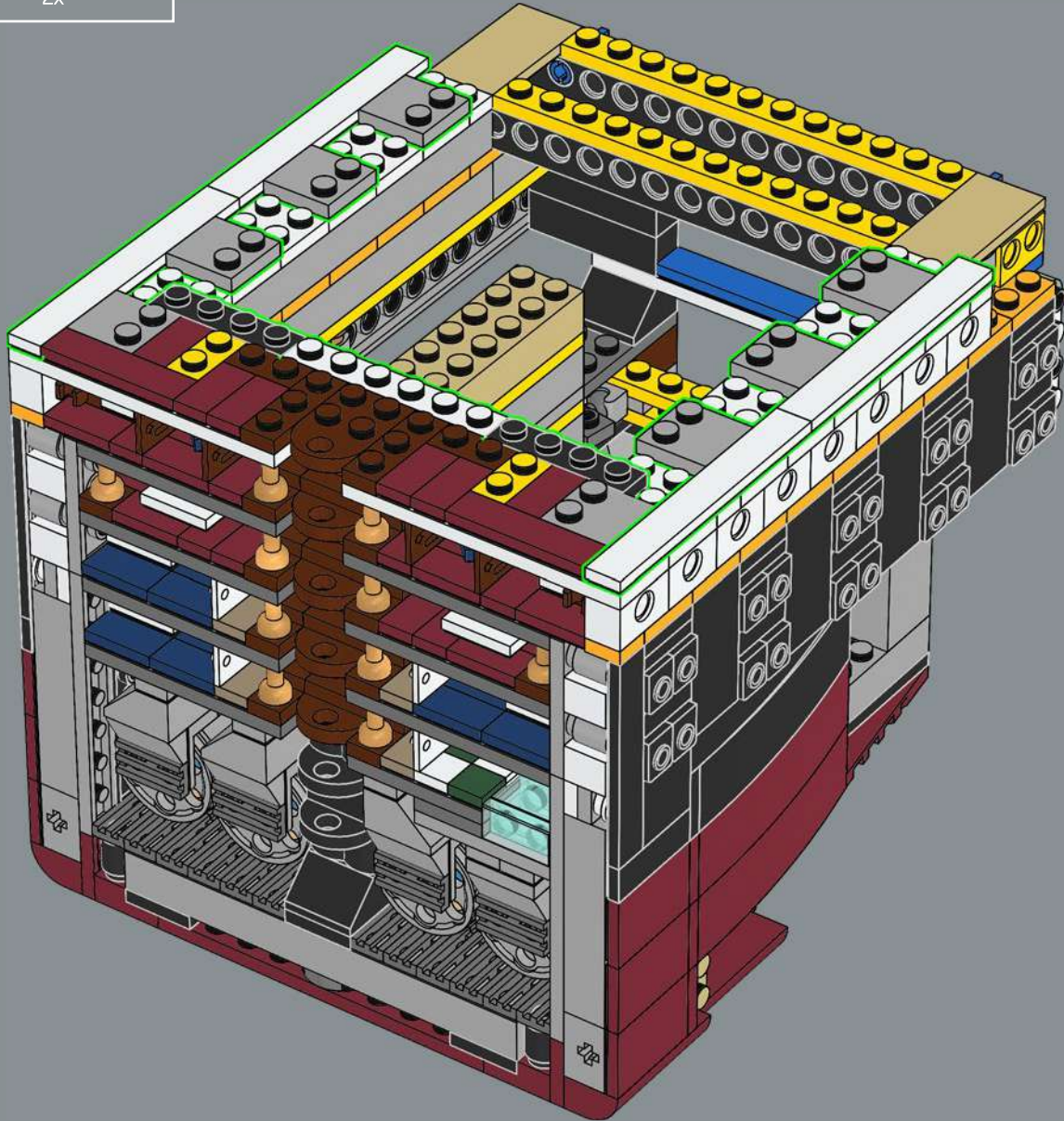

The RMS in RMS *Titanic* stands for Royal Mail Ship and she carried a large amount of cargo for both the Royal Mail and the US Postal Service.



228

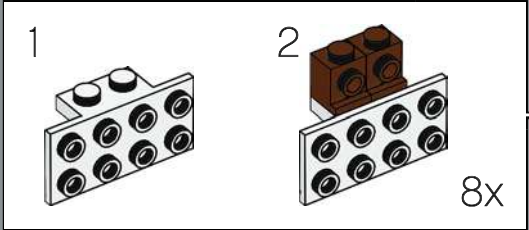
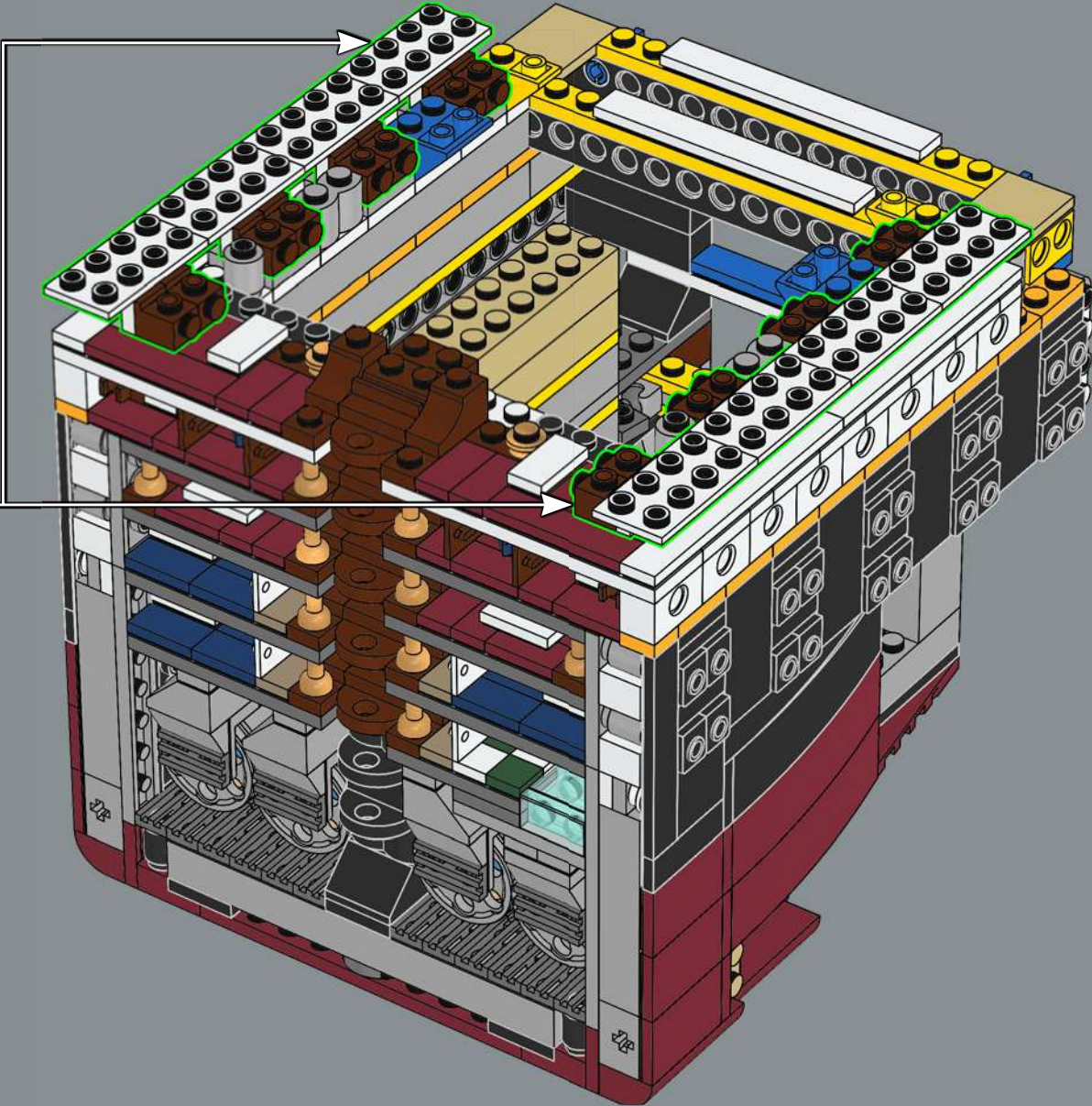

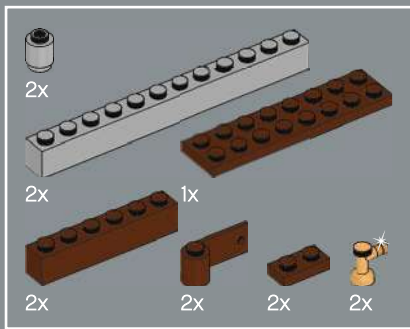

229

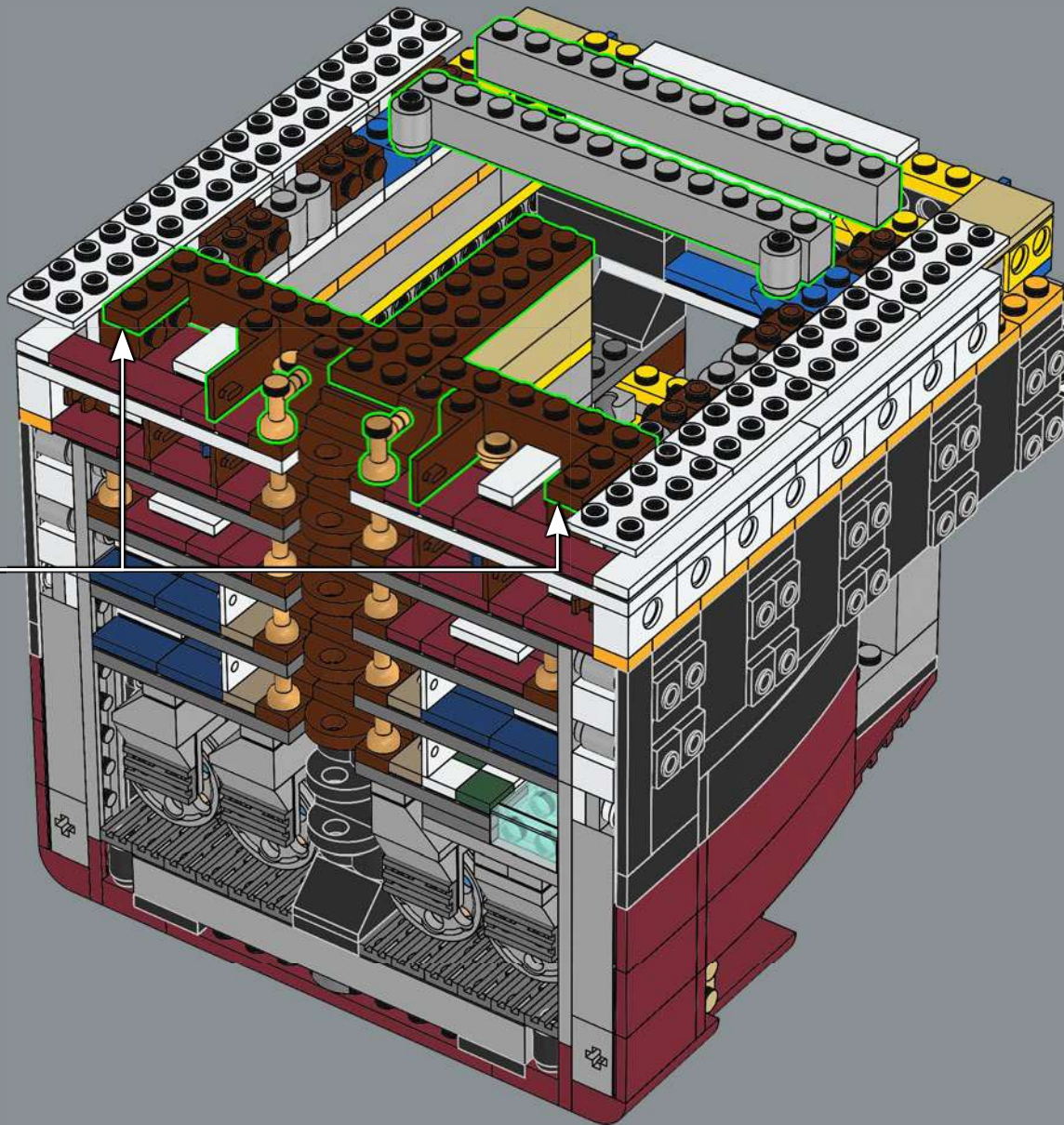

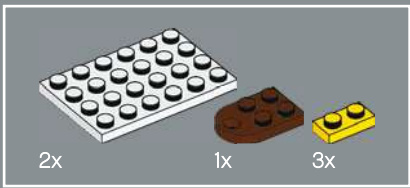

230

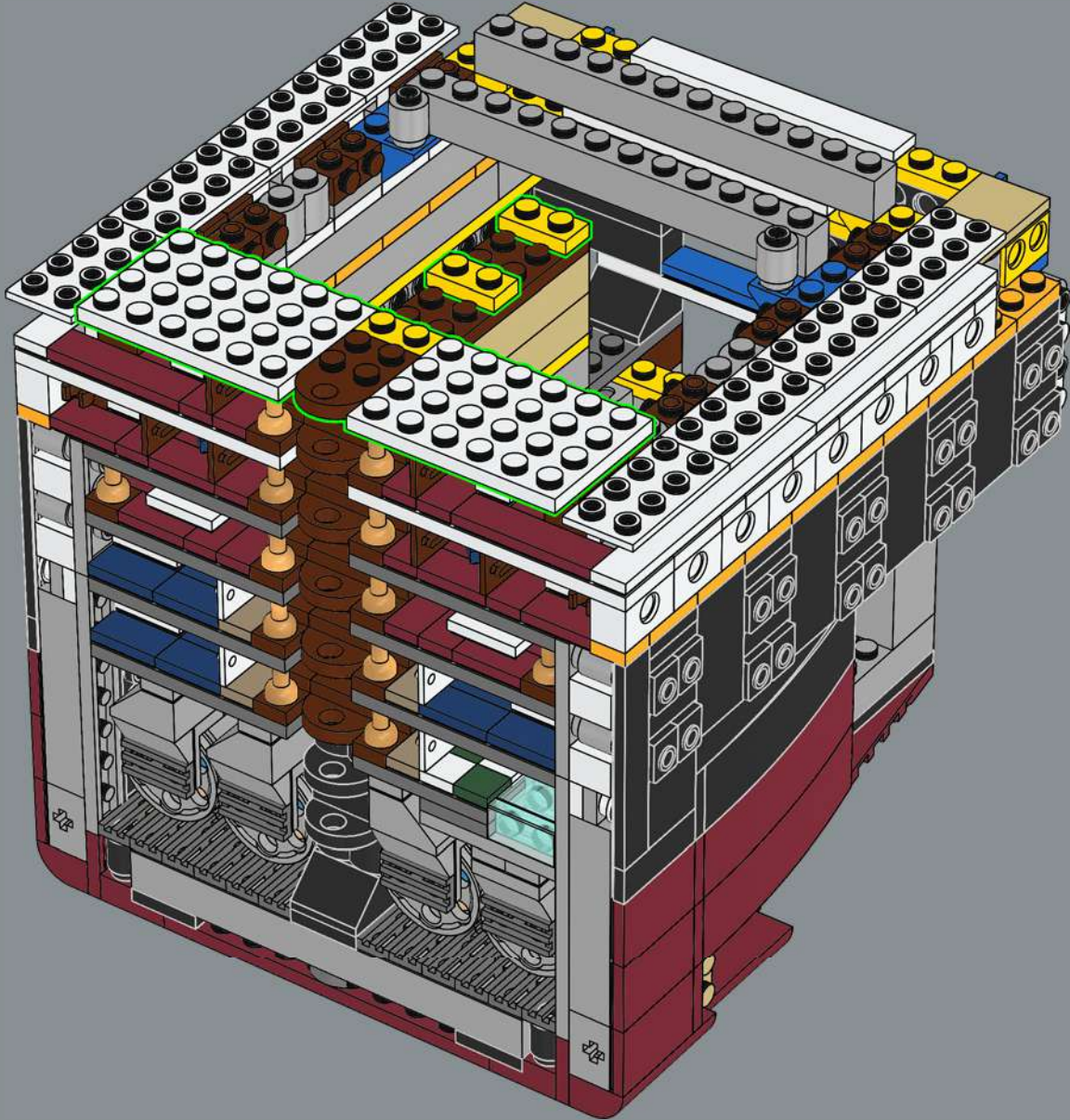

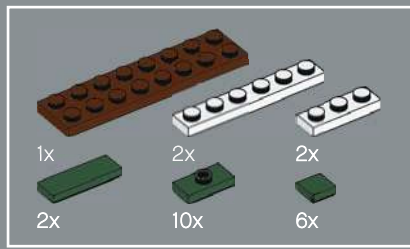

231

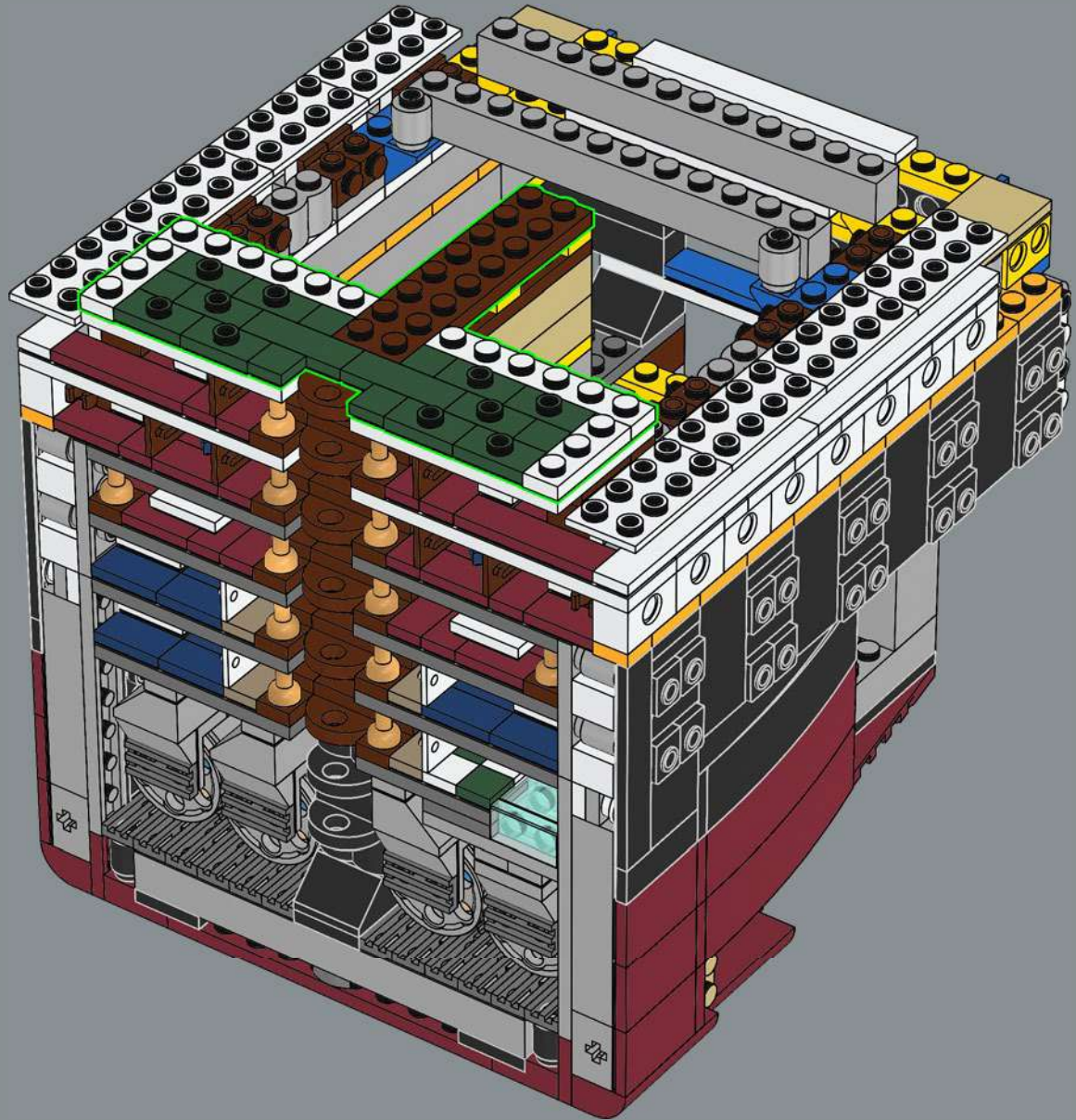

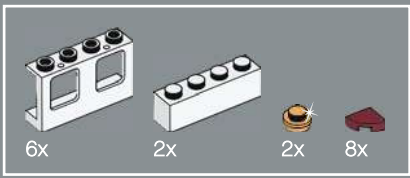

232

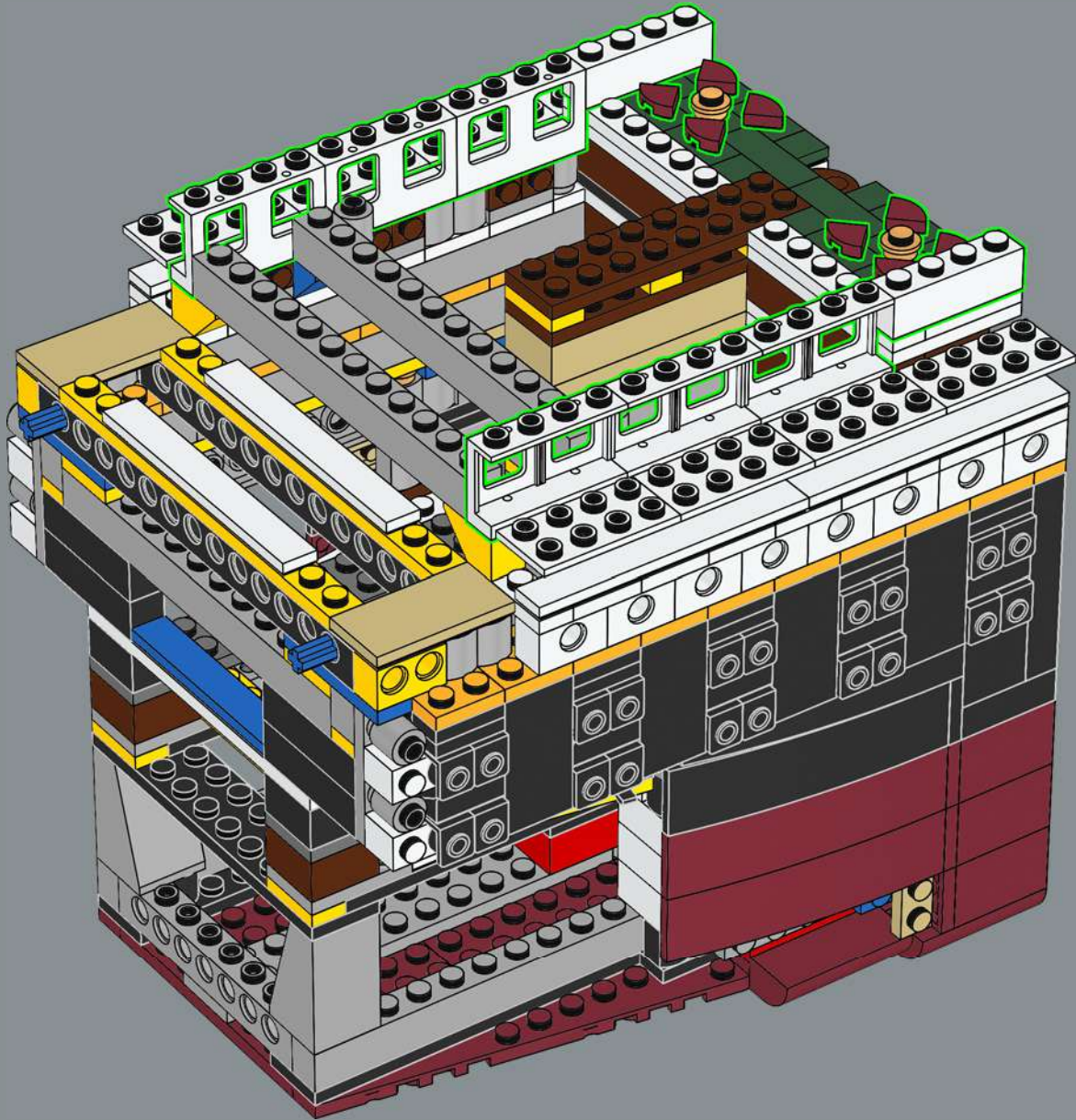

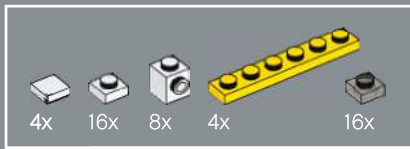

233

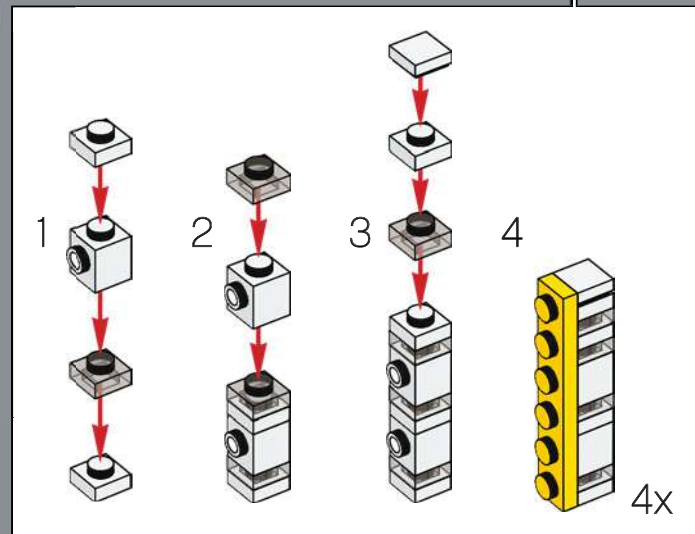
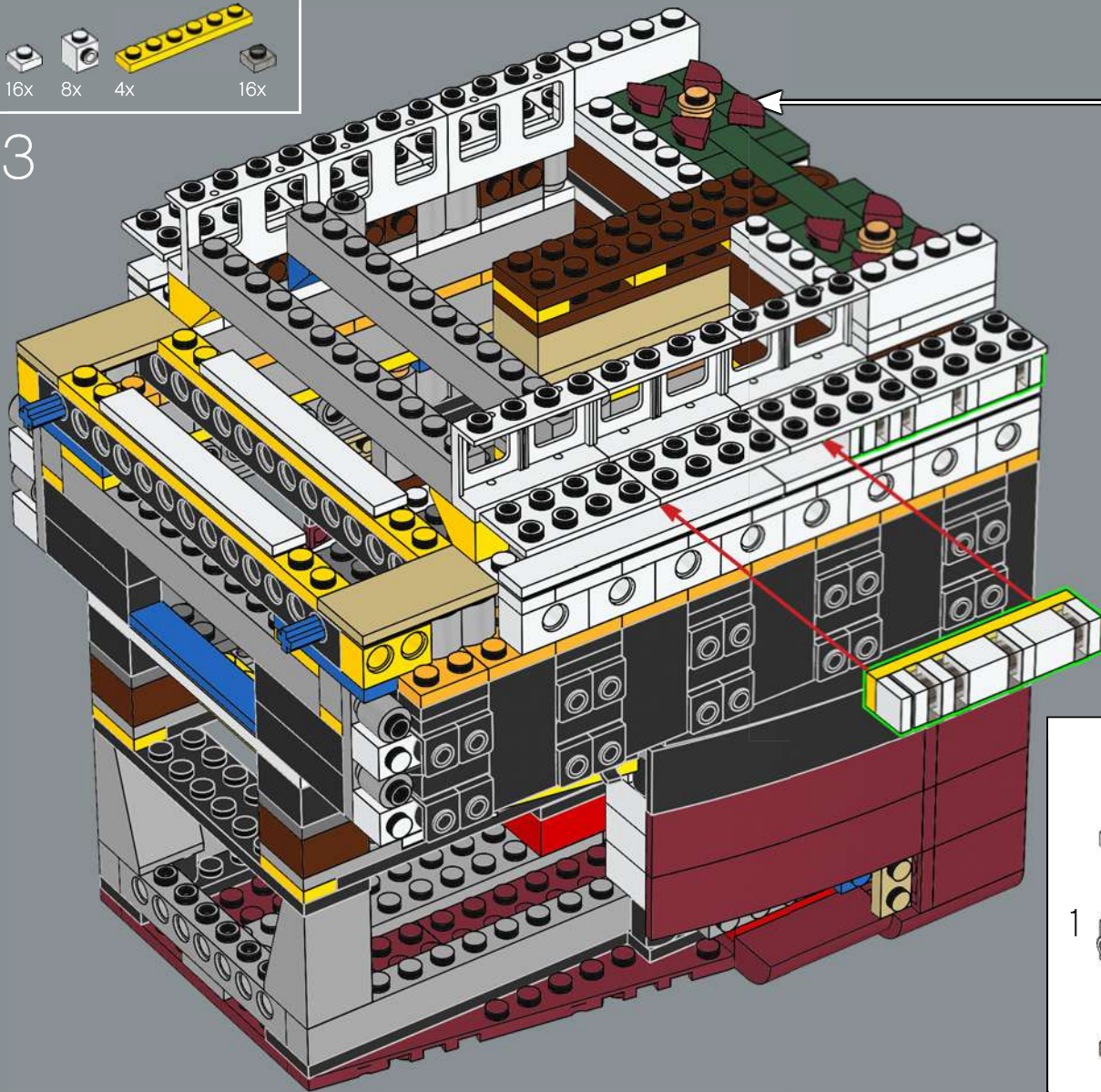

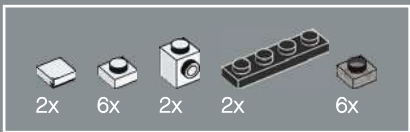

234

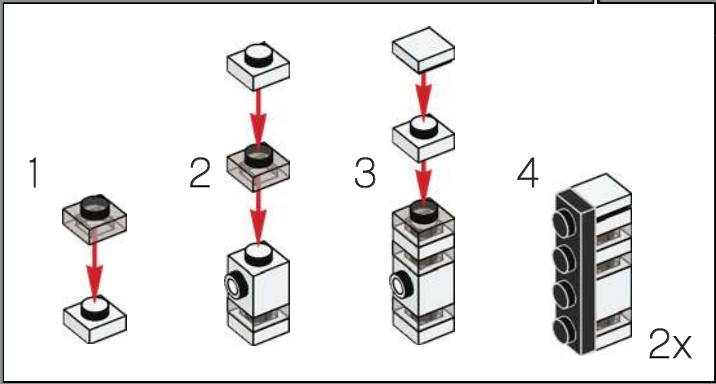
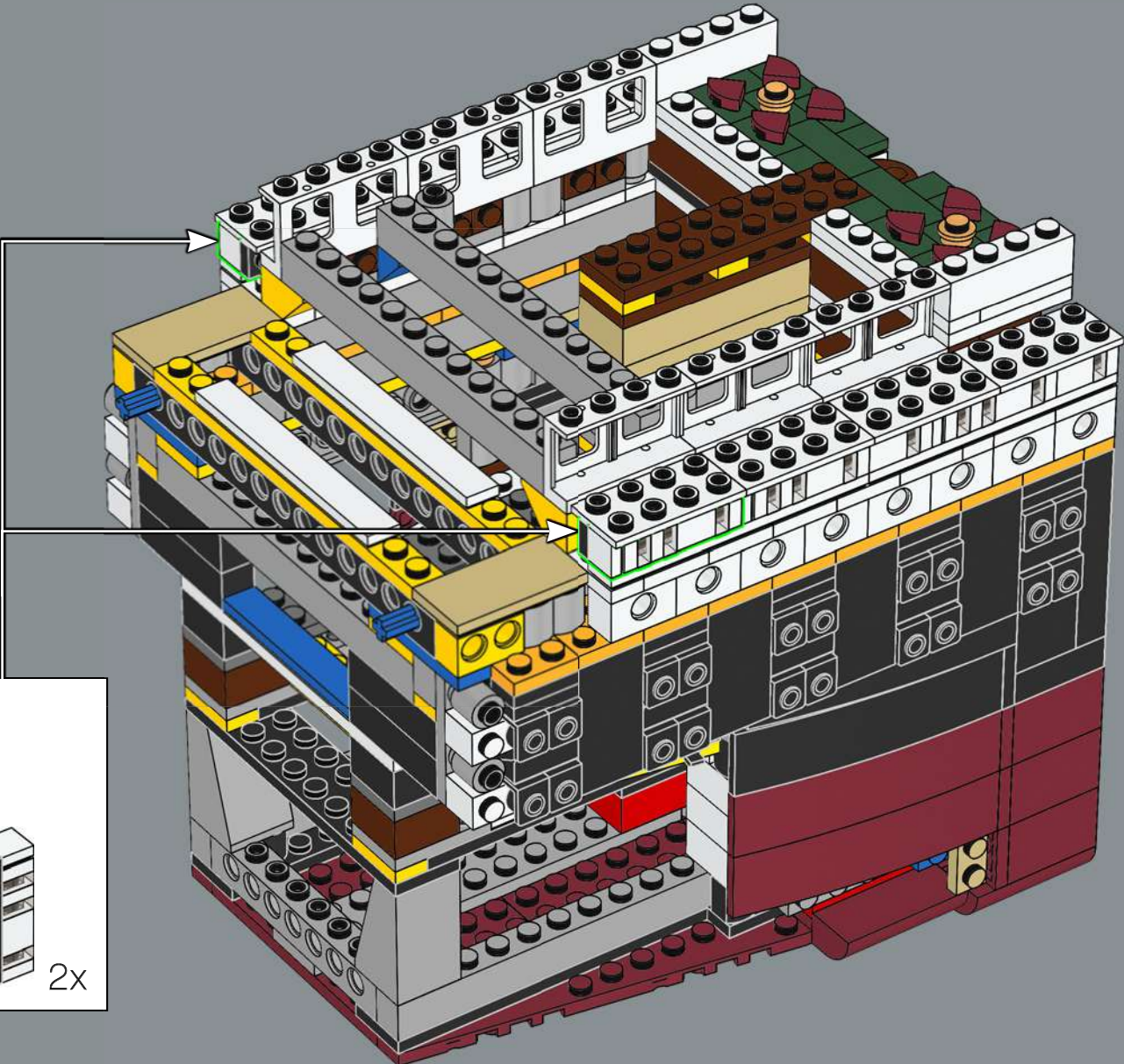

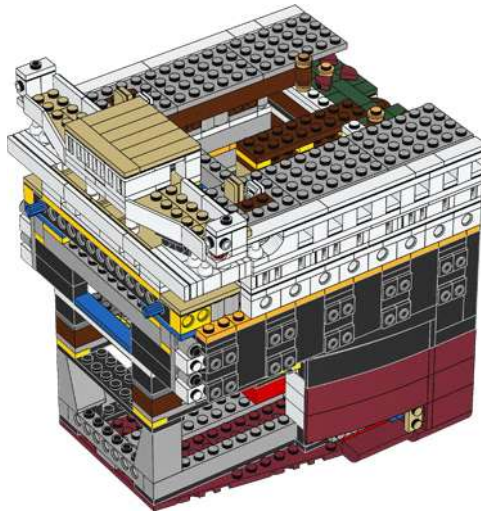
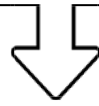

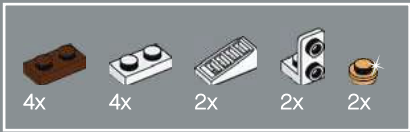

235

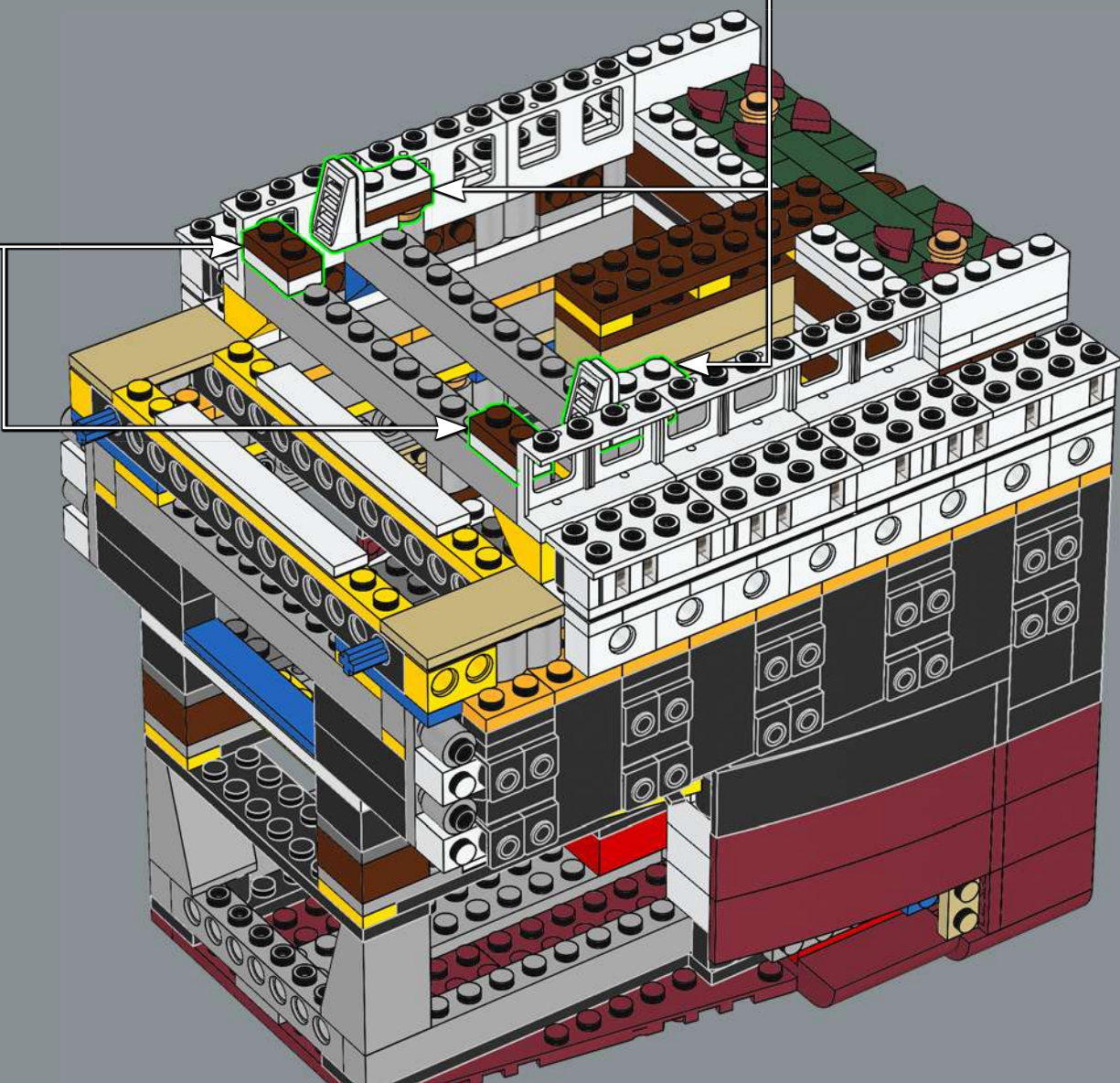
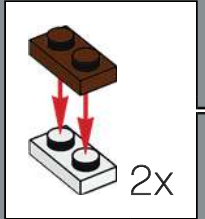
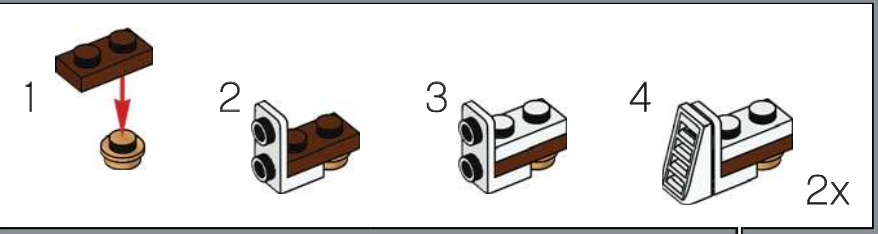

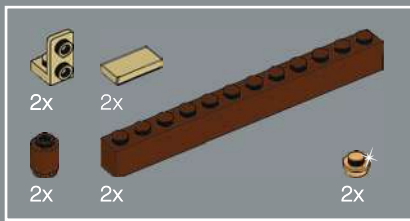

236

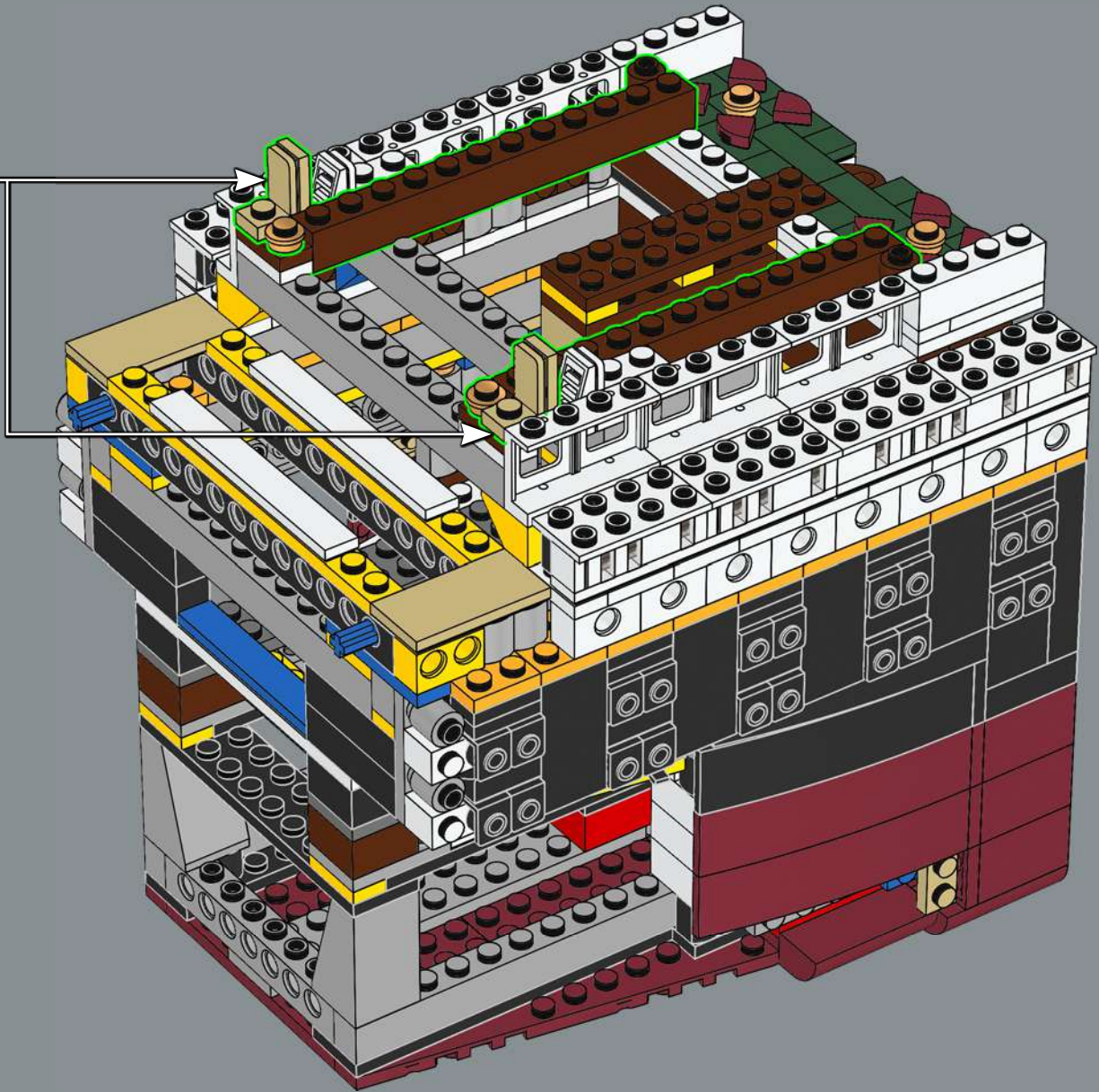
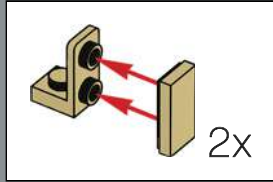

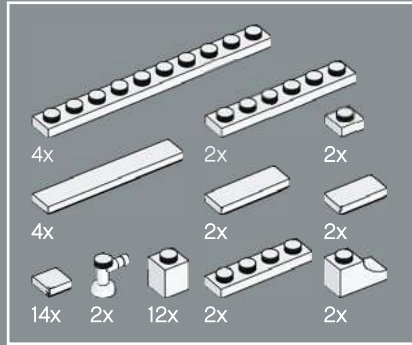
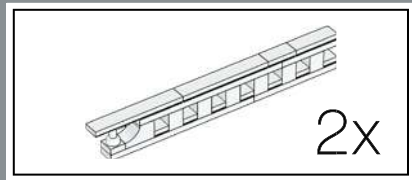

237

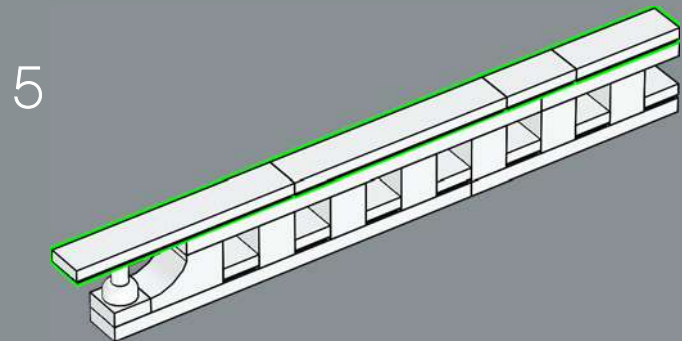
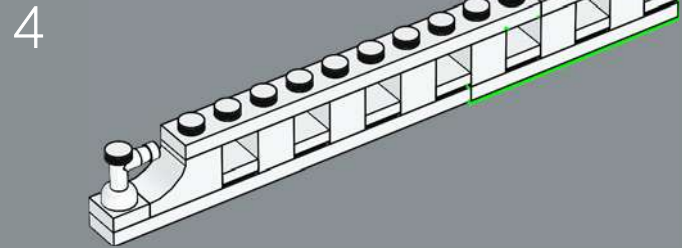
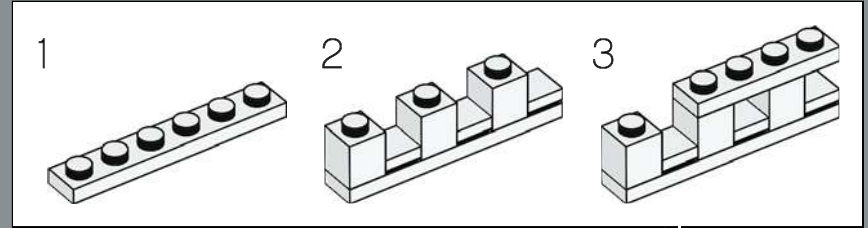
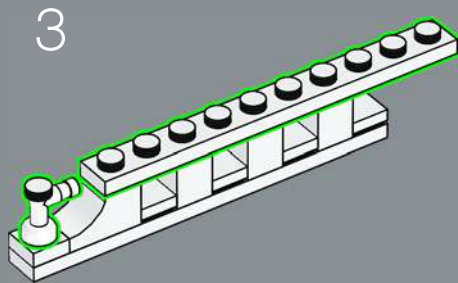
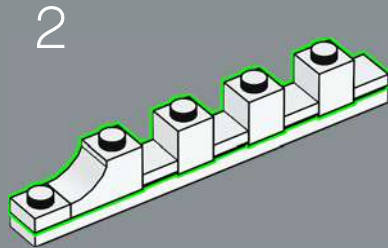
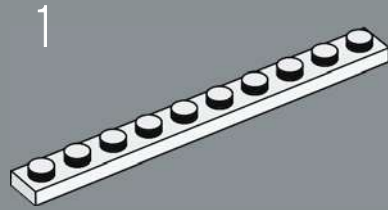

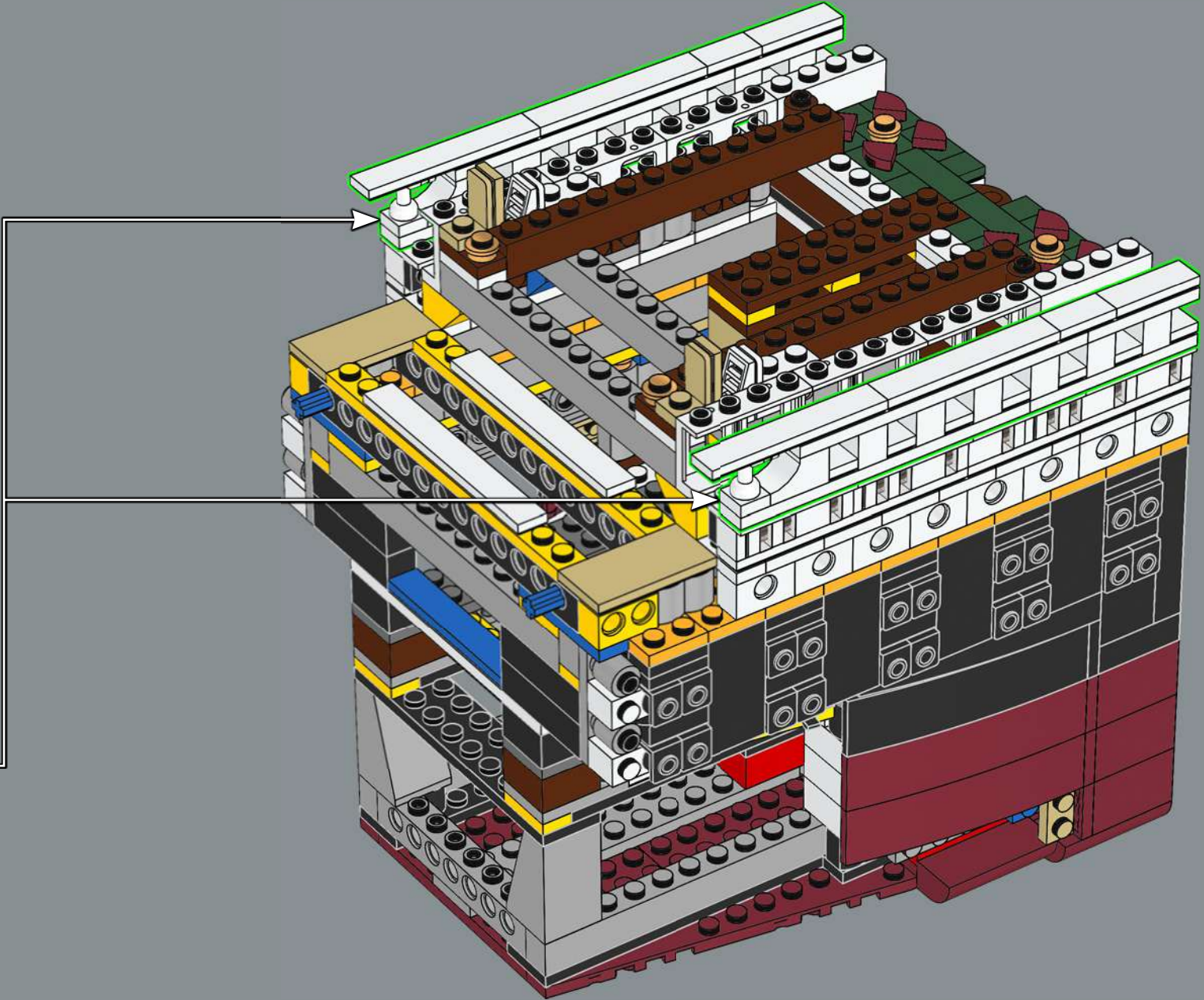

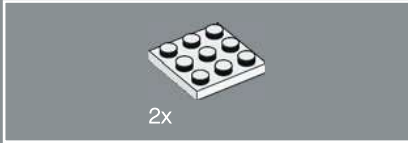
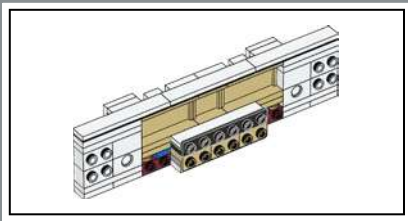

238

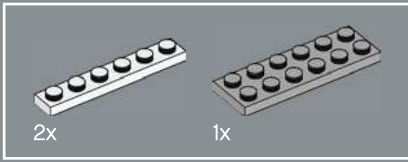
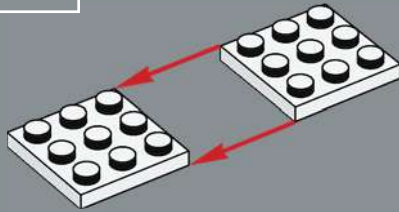

239

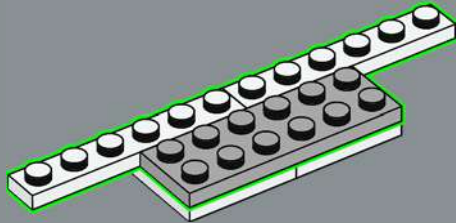

240

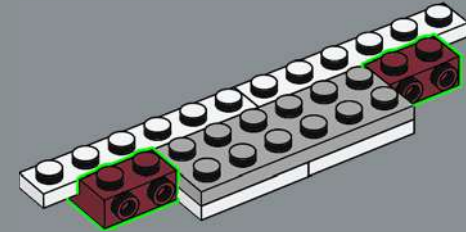

241

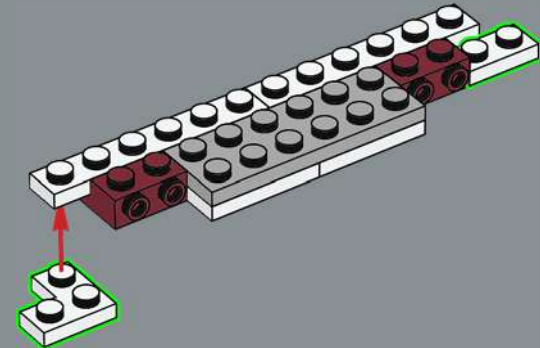

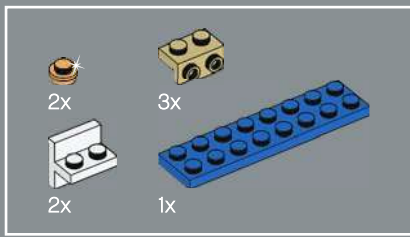

242

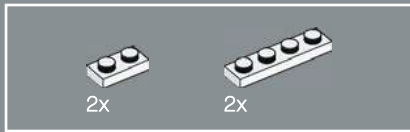
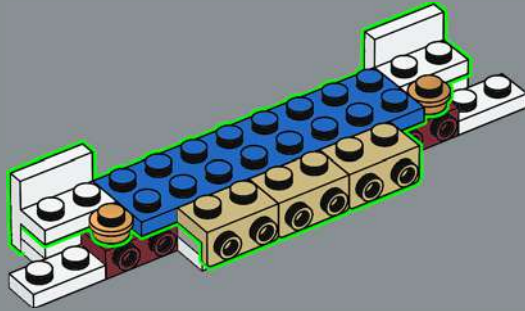

243

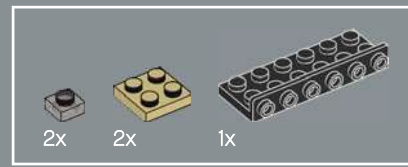
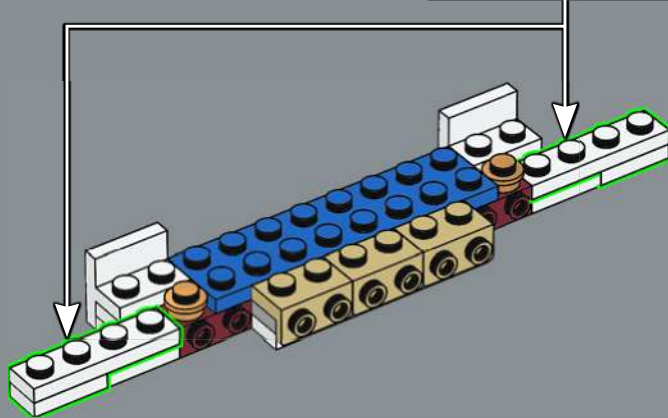
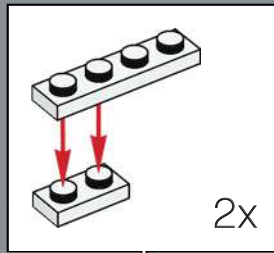

244

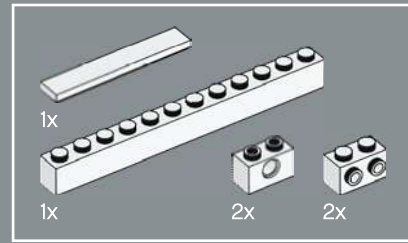
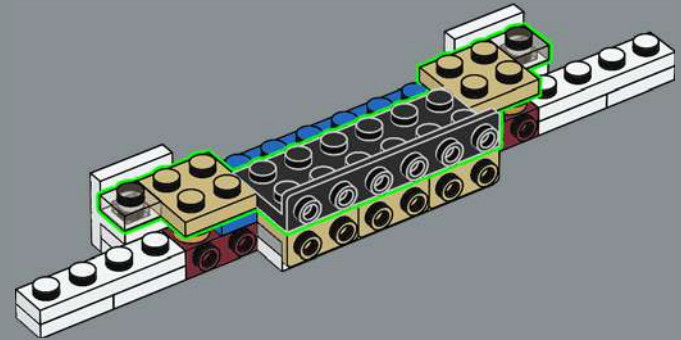

245

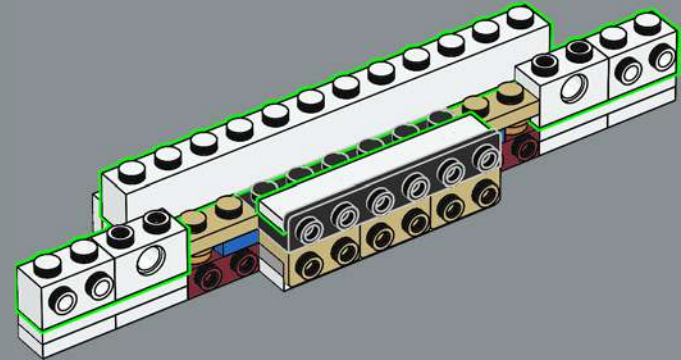

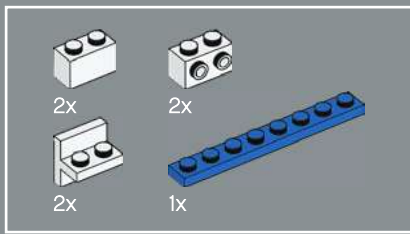

246

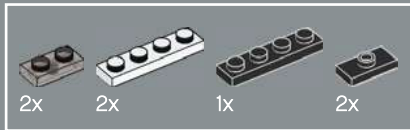
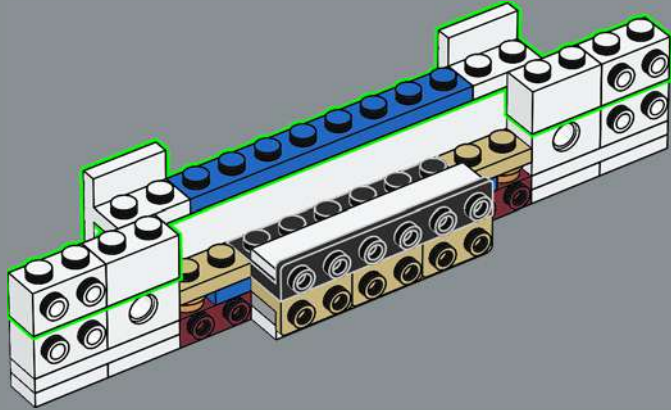

247

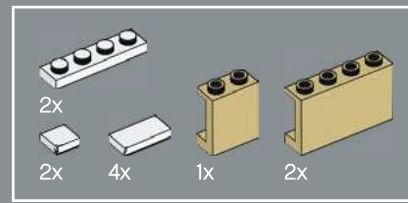
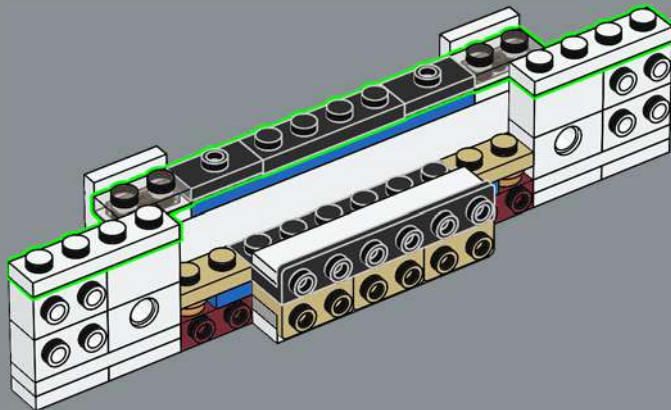

248

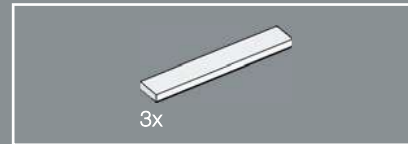
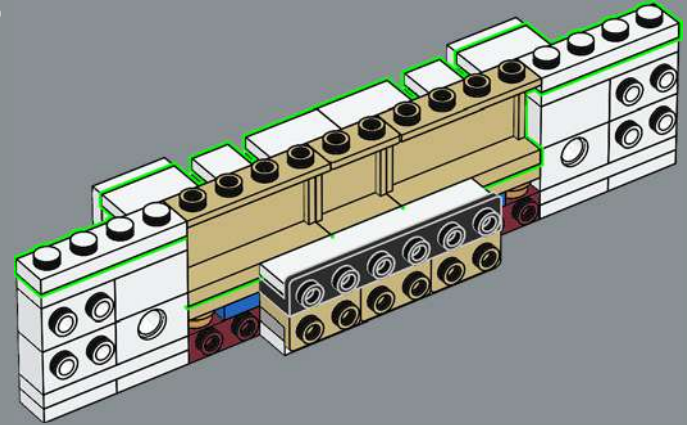

249

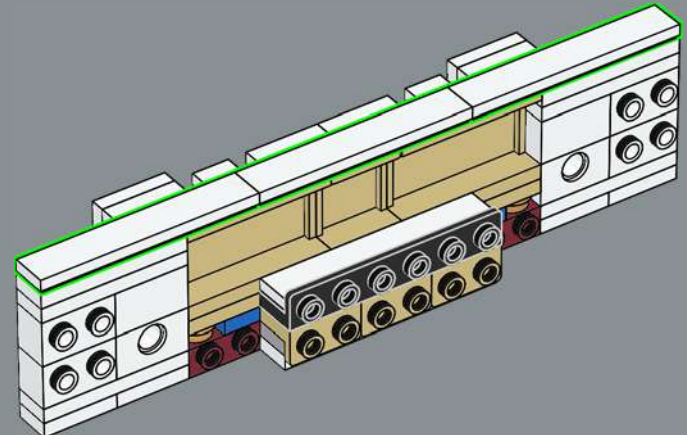

250

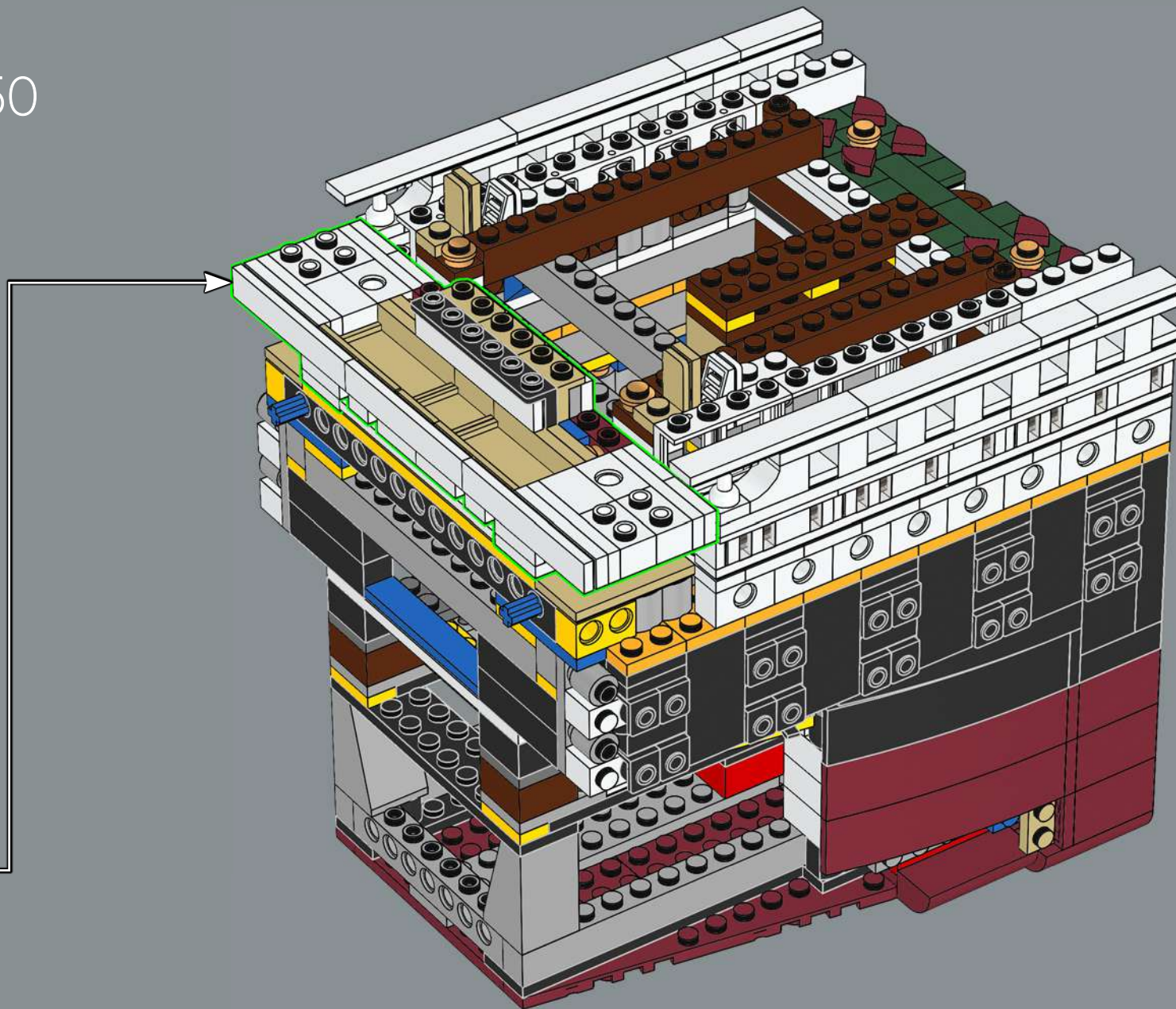

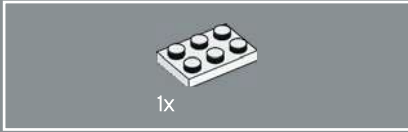
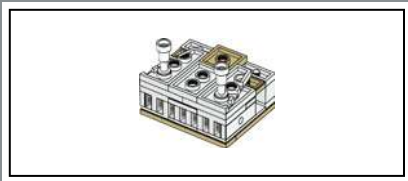

251

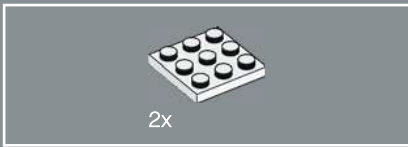

252

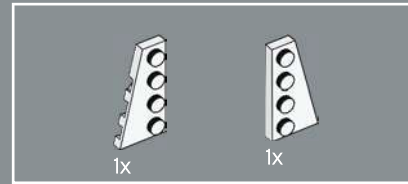
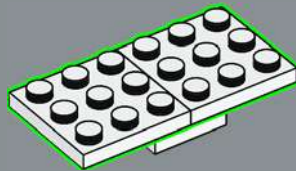

253

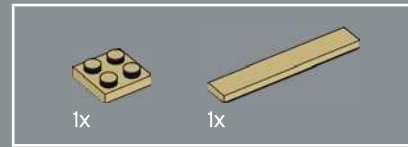
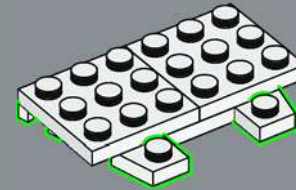

254

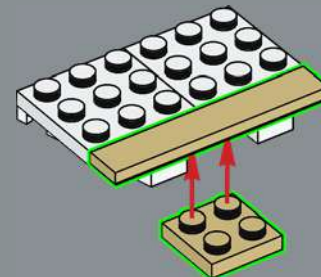

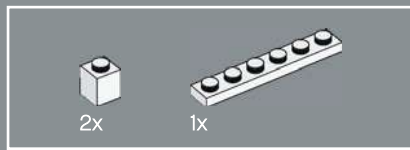

255

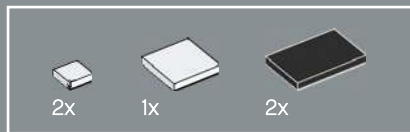
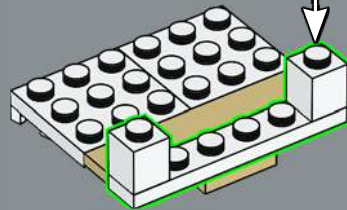
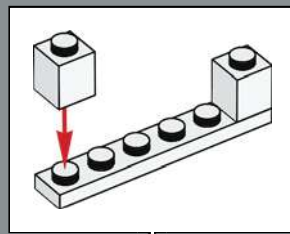

256

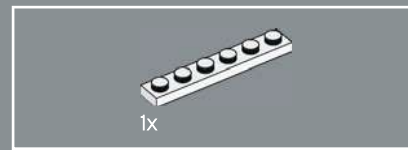
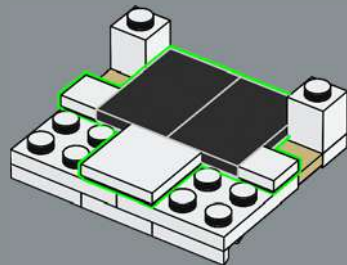

257

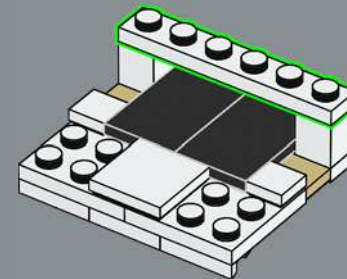

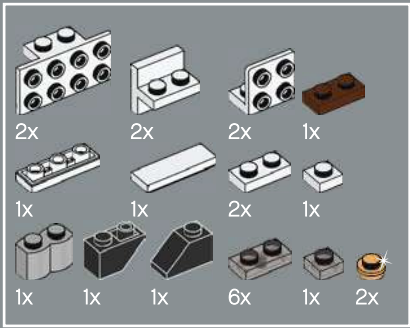

258

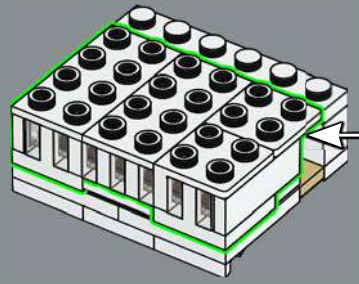
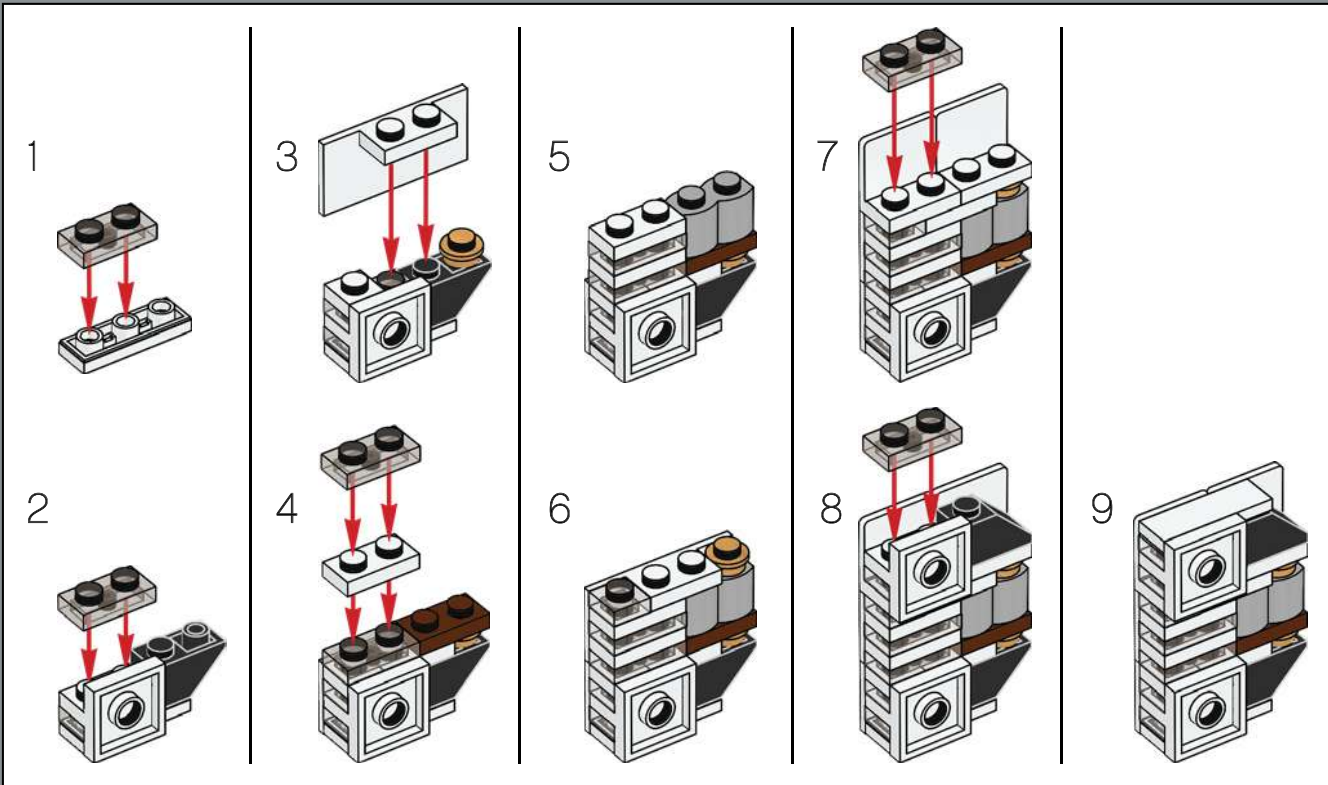

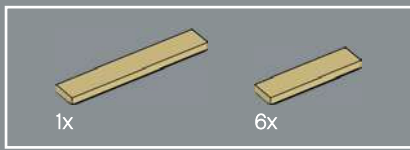

259

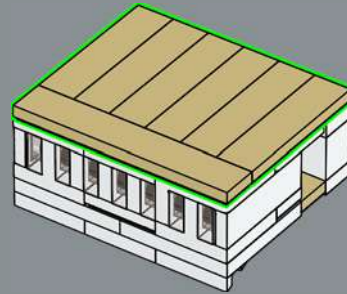

260

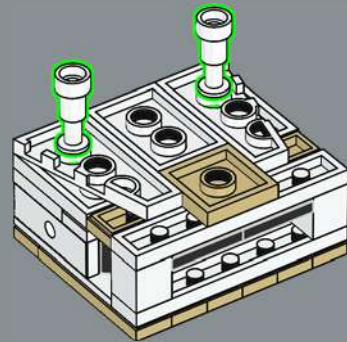

The bridge stood 2.4 meters (8 ft.) above the deck and extended out to either side so that the ship could be controlled while docking.

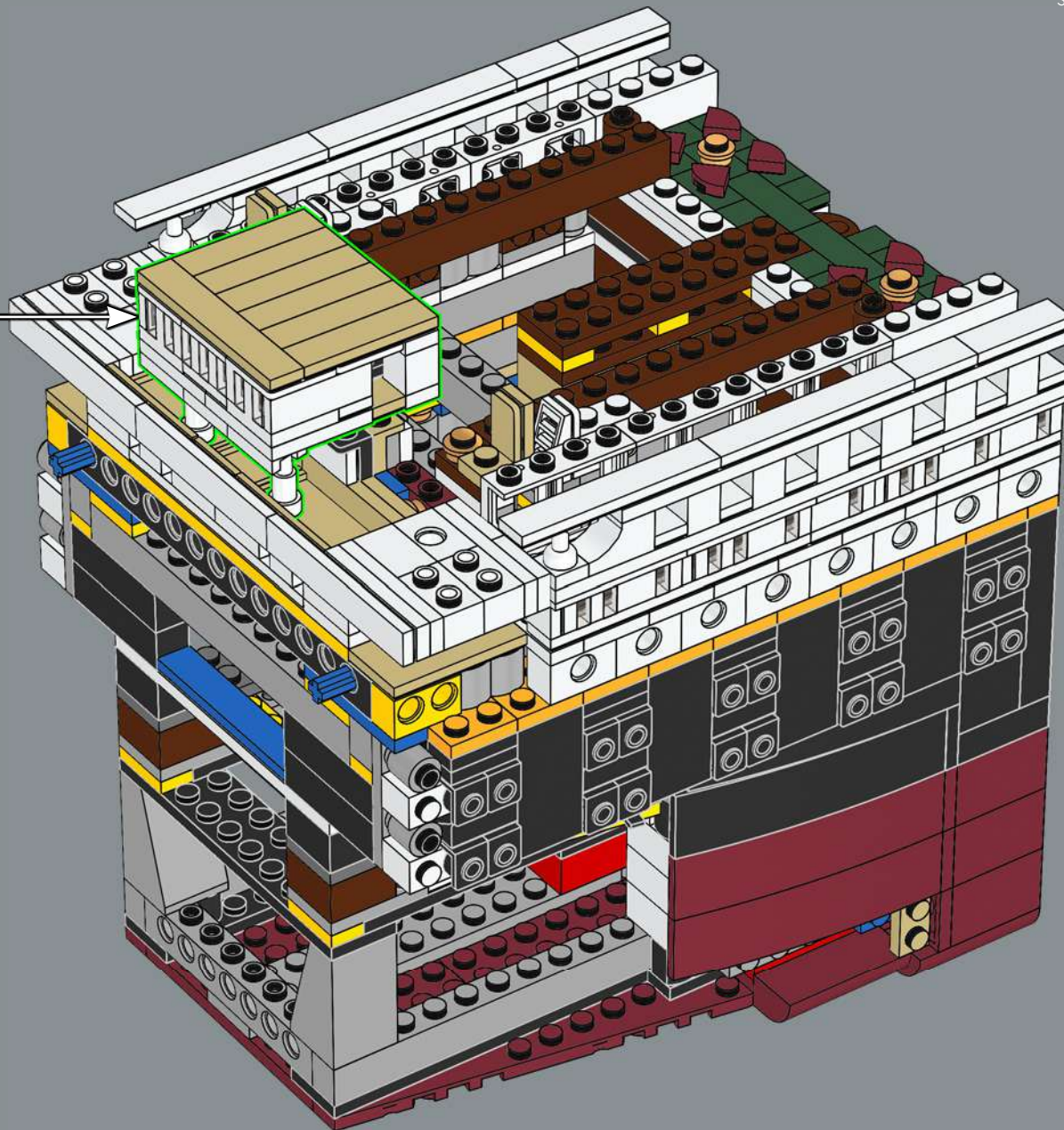



262

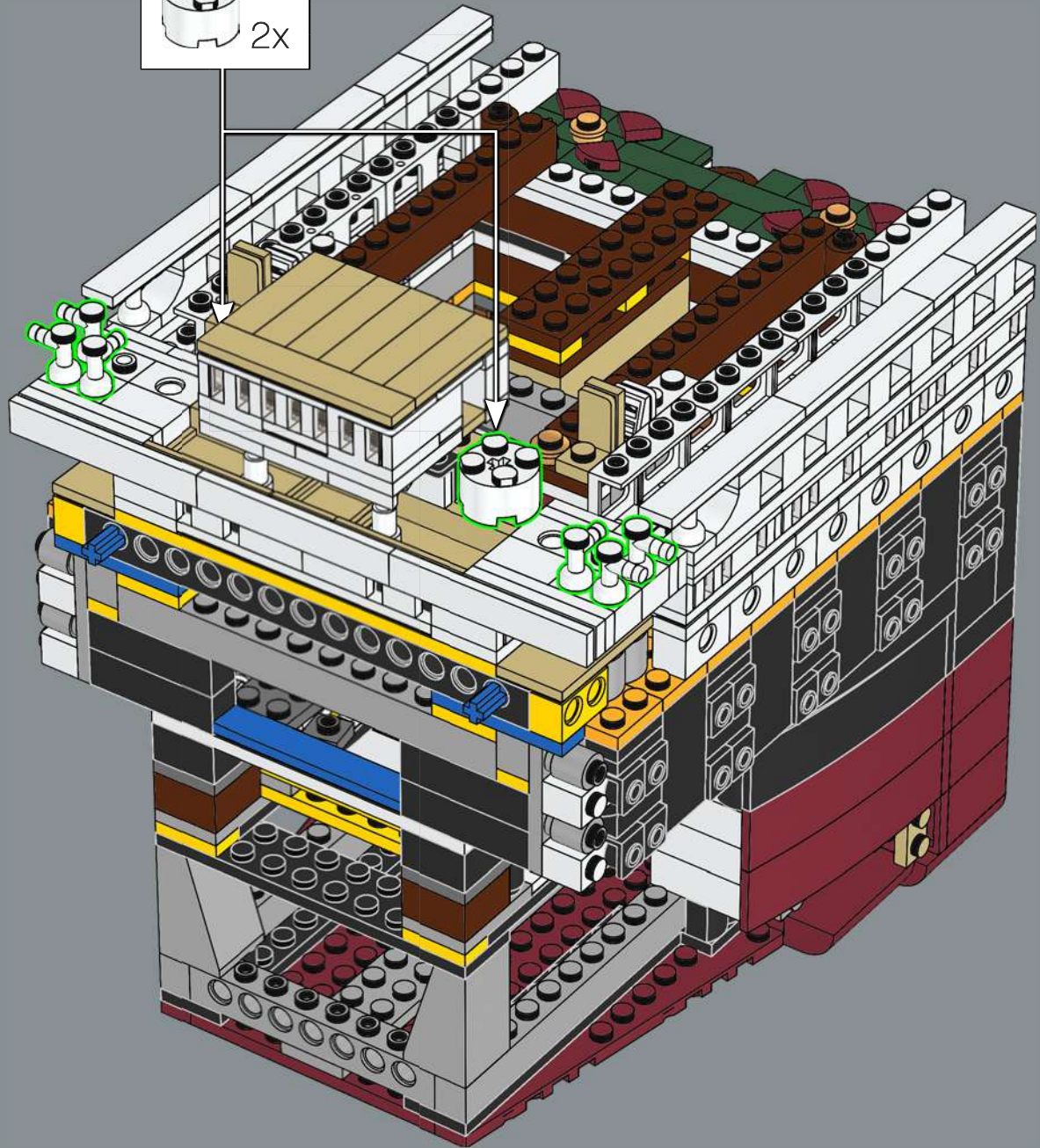
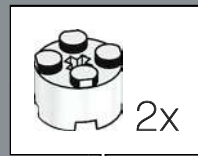

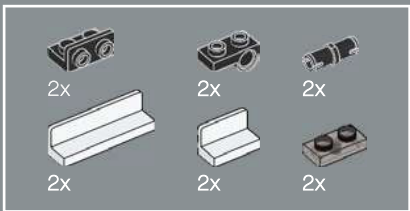

263

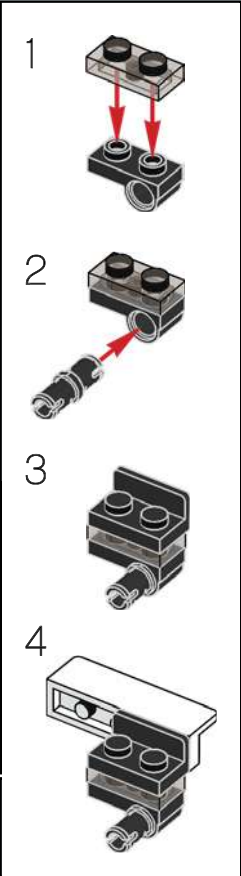
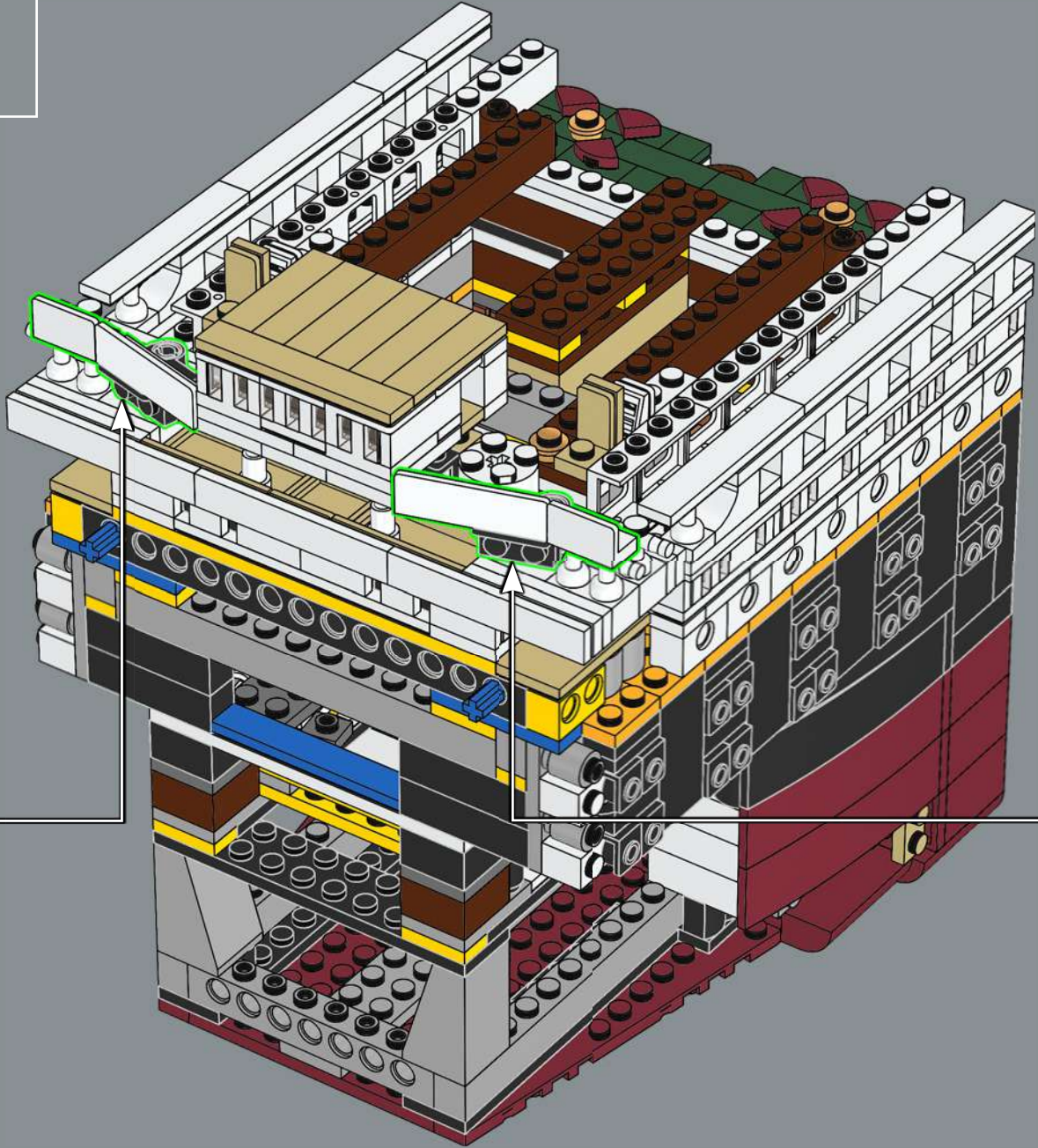
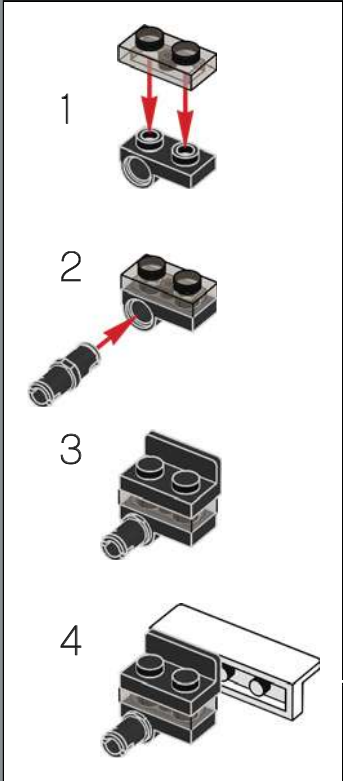

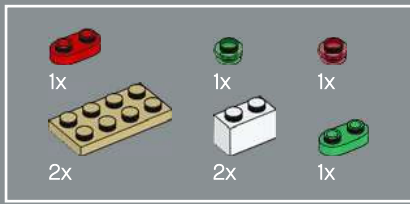

264

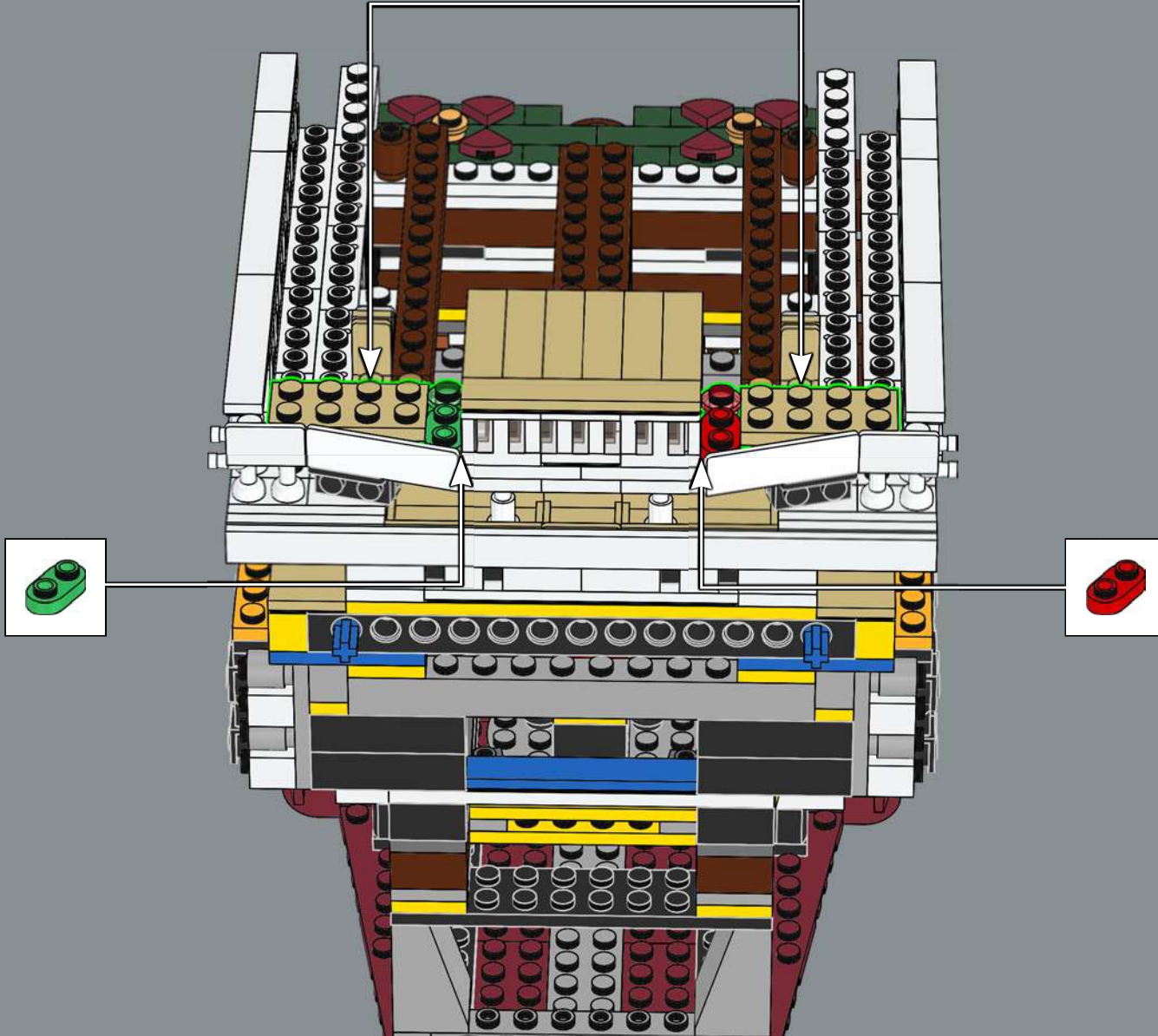
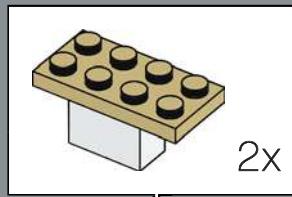

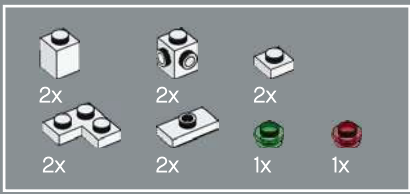

265

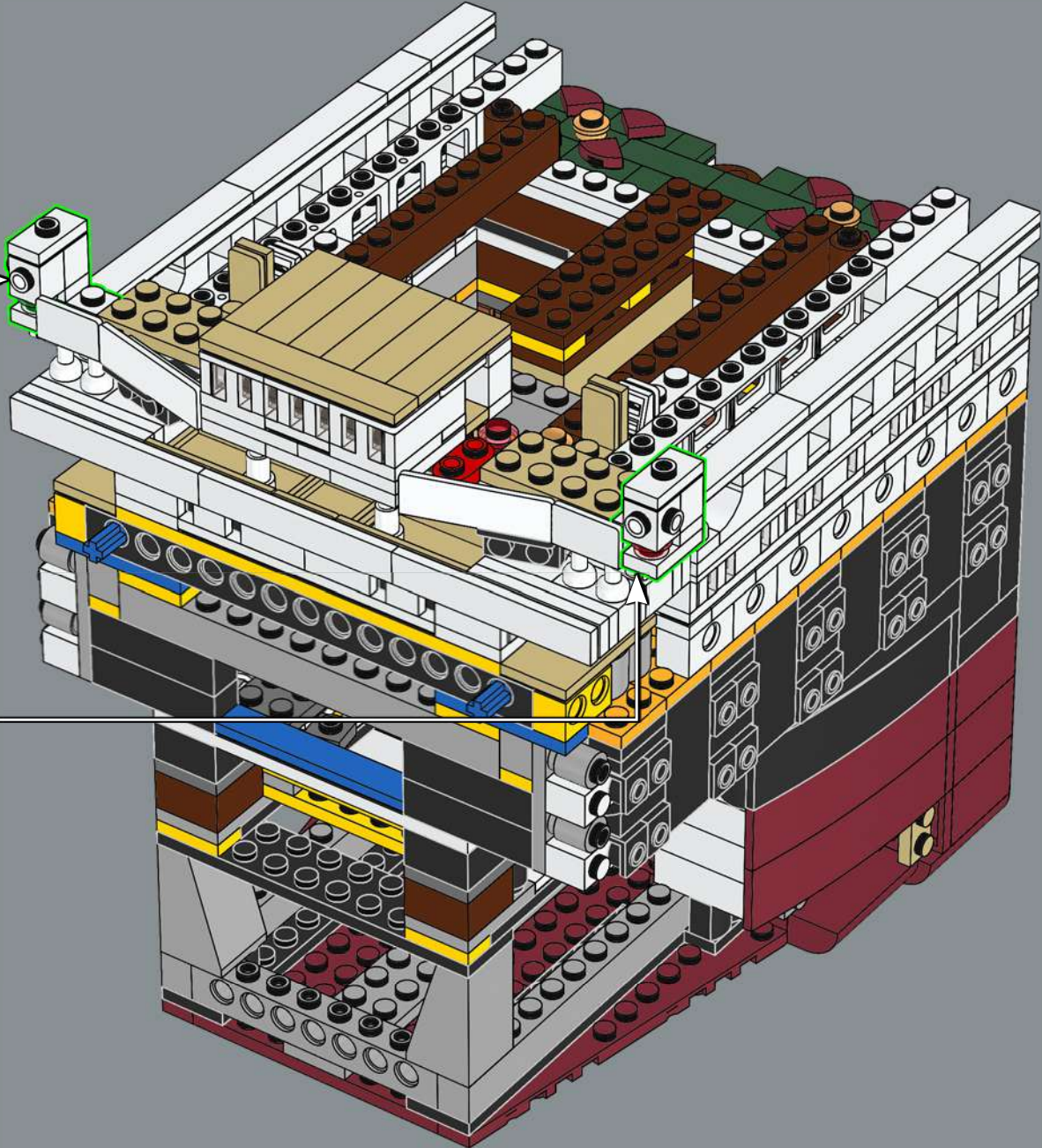
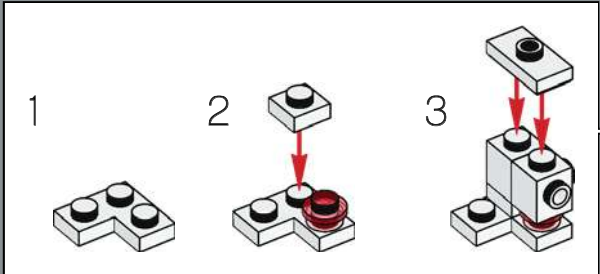
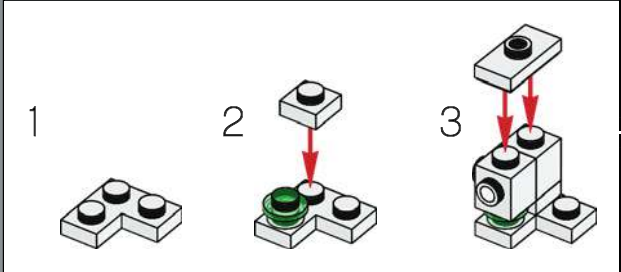

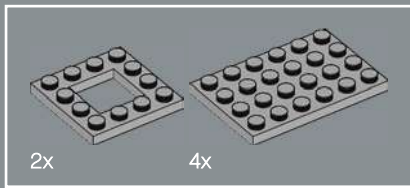

266

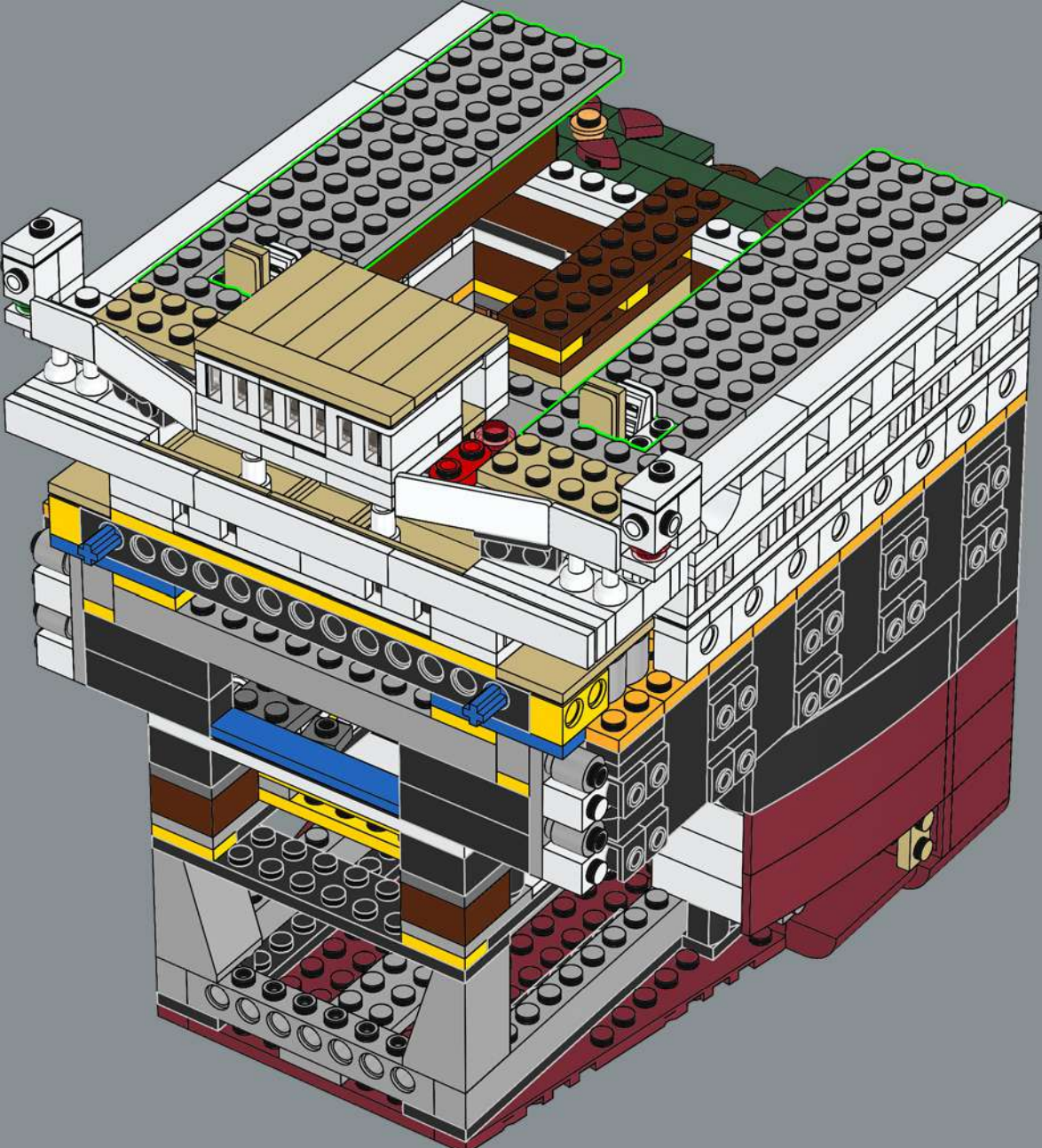

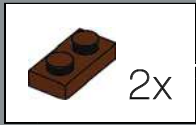
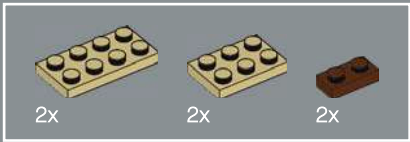

267

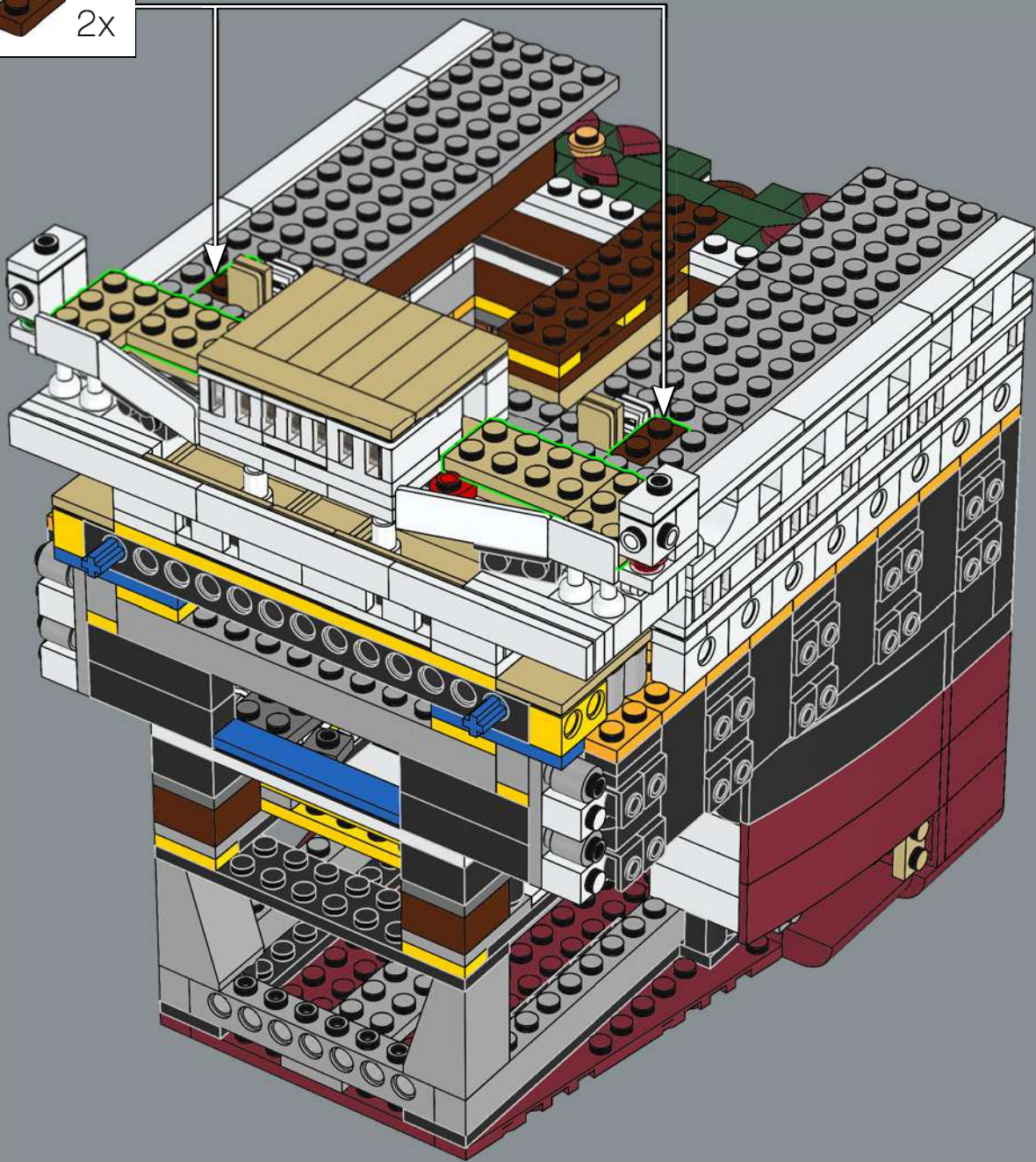

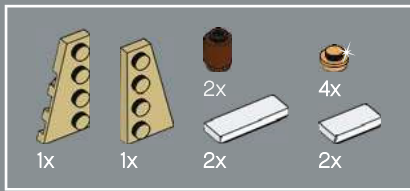

268

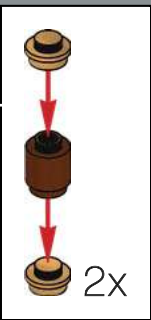
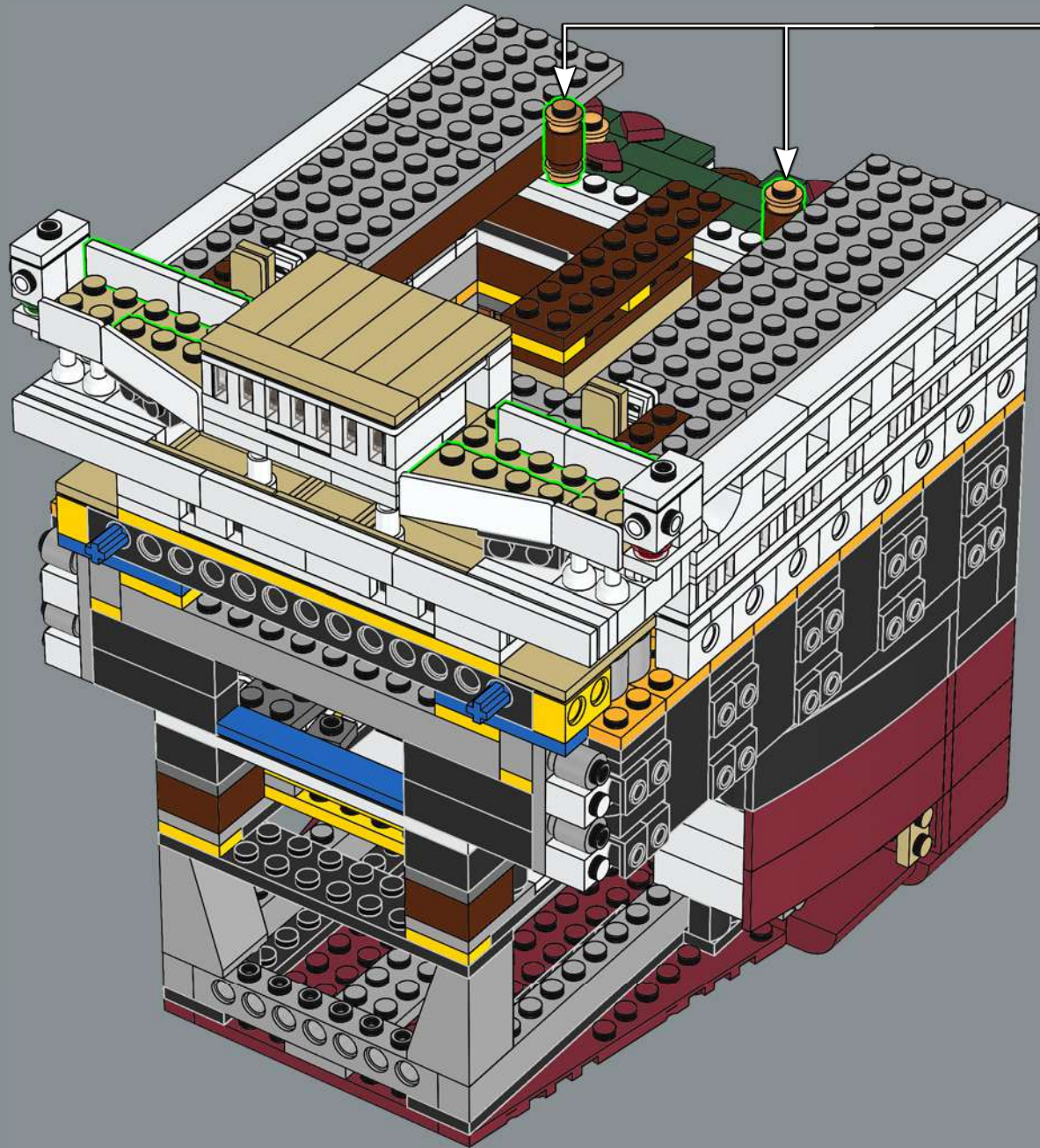
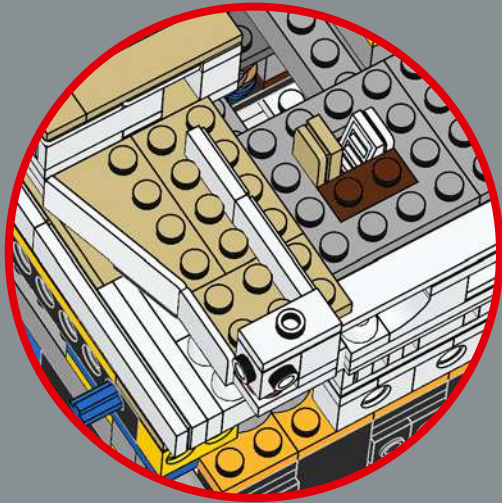
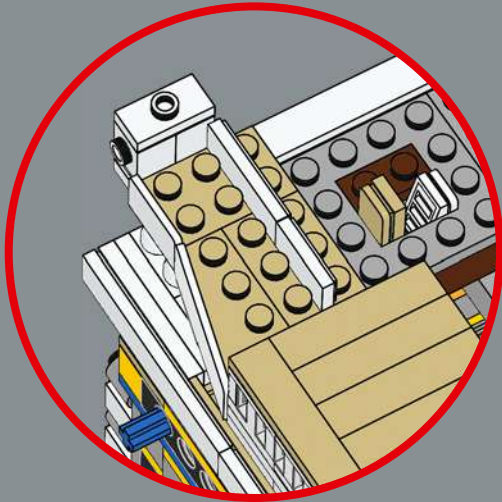

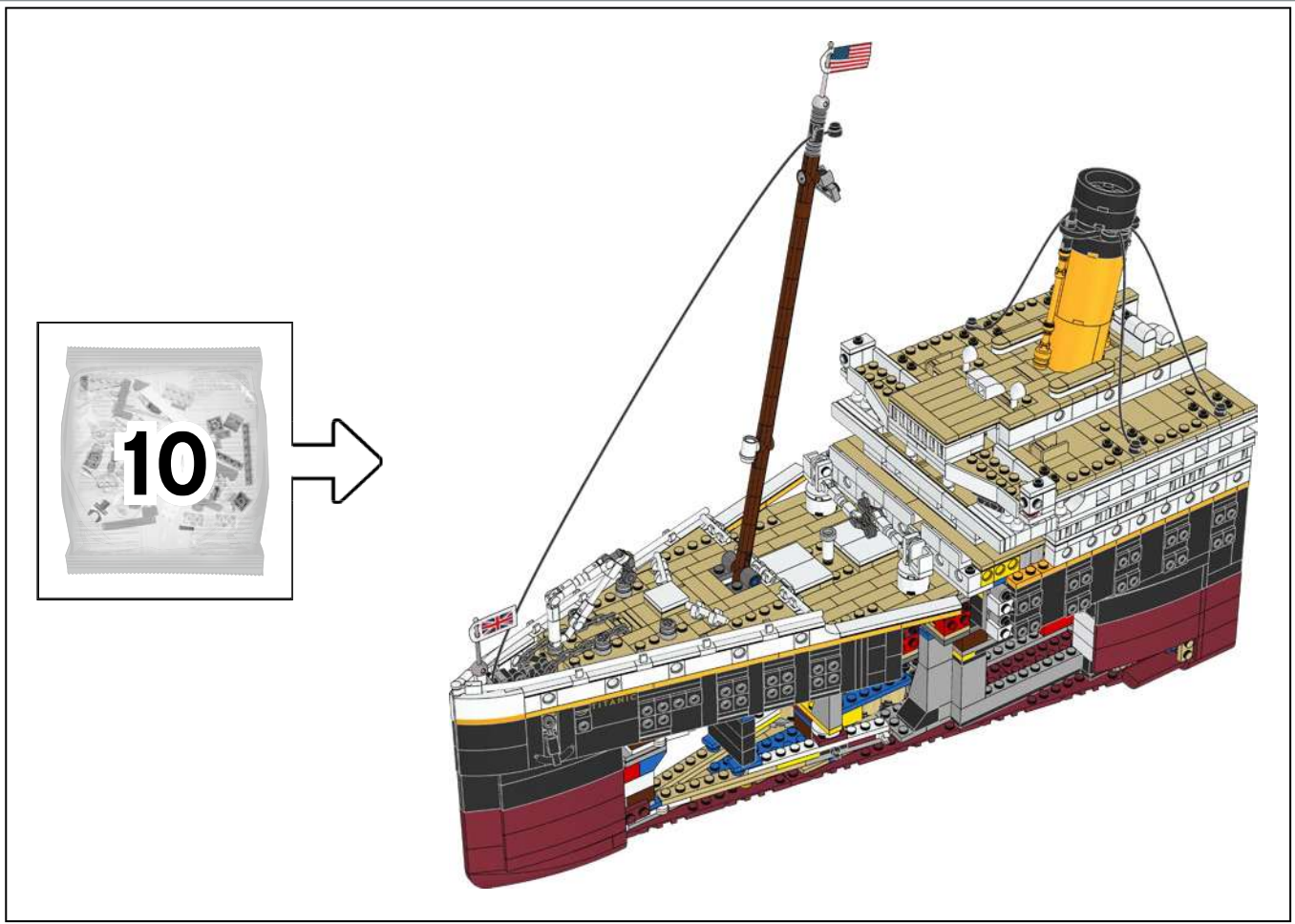

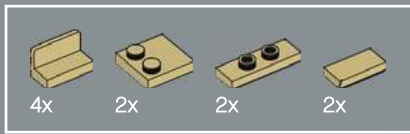

269

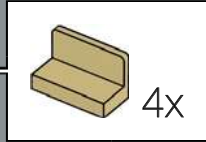
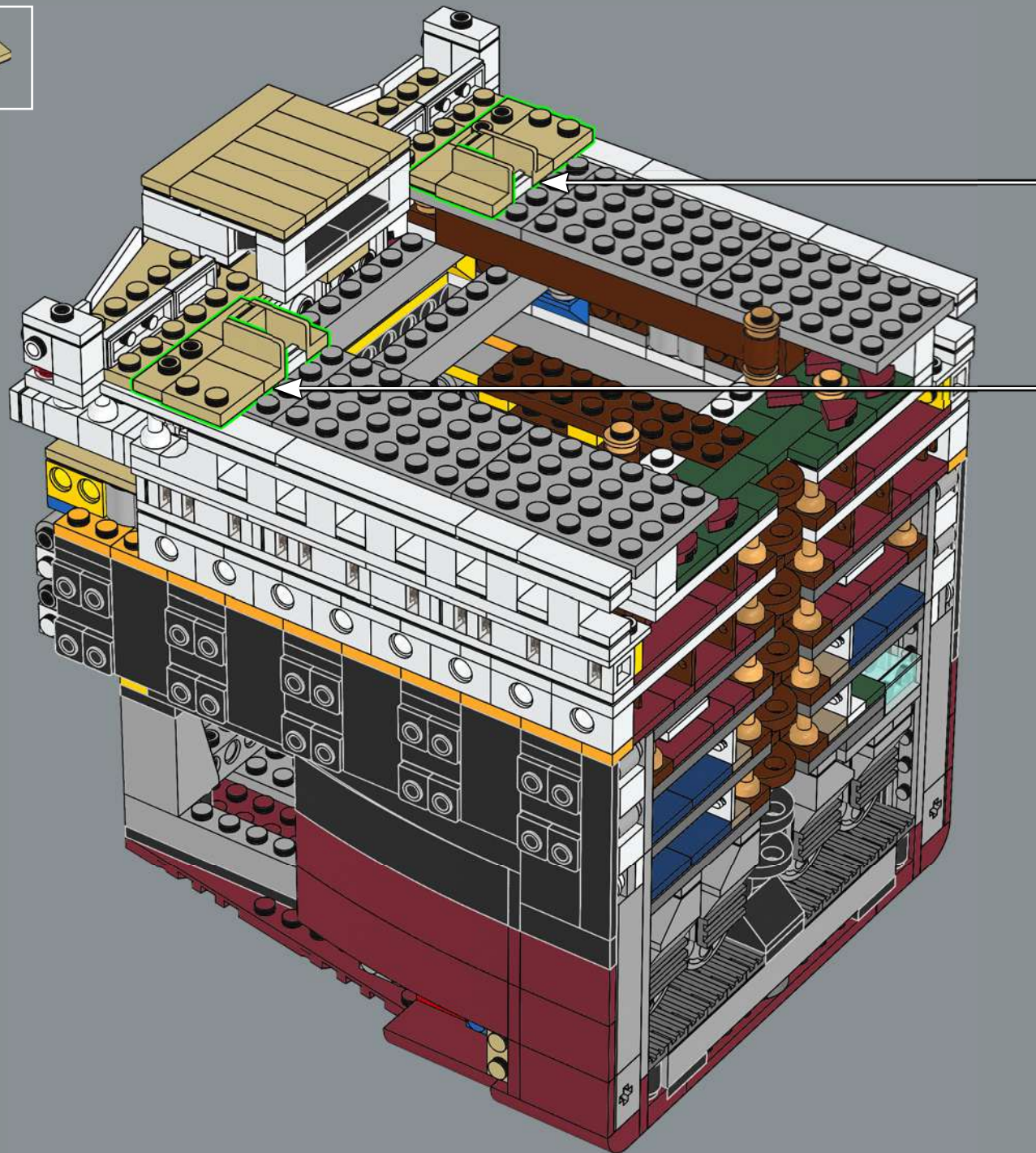

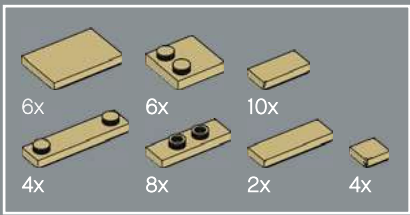

270

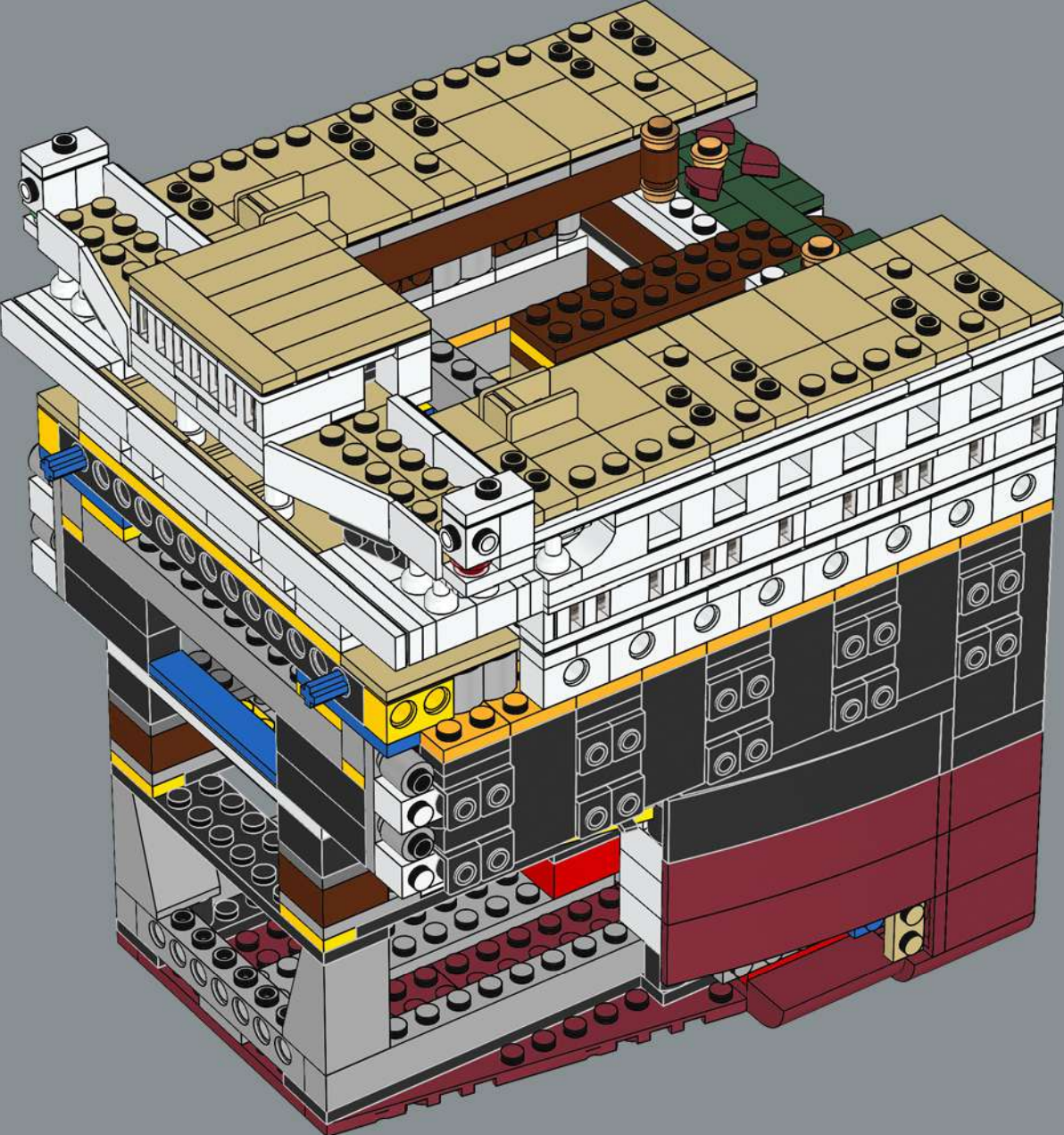

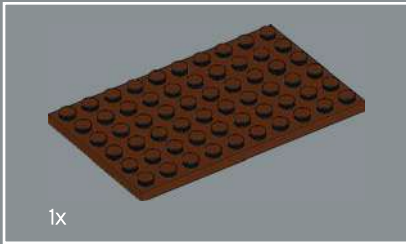
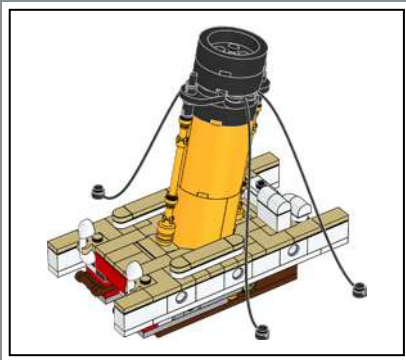

1x

271

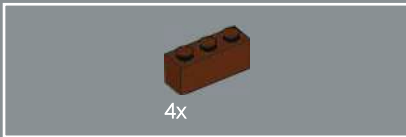

4x

272

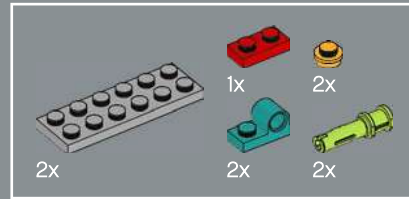
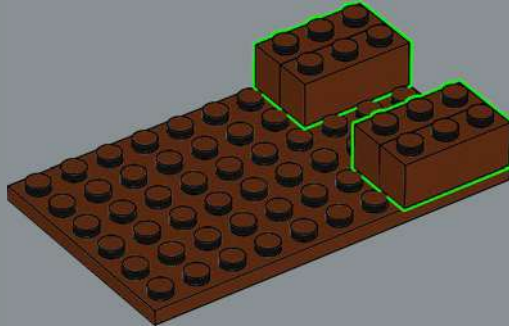
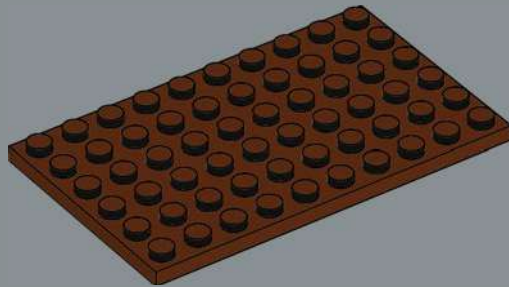

273

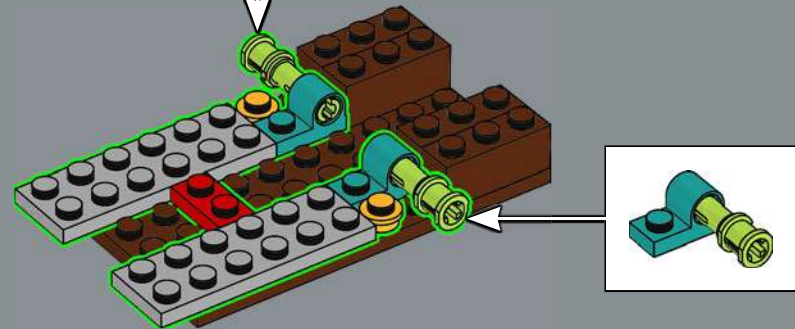
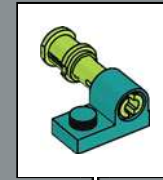

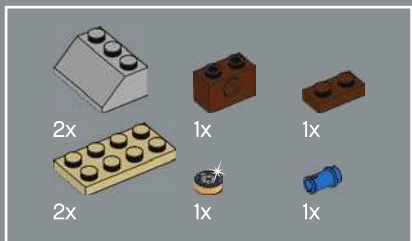

274

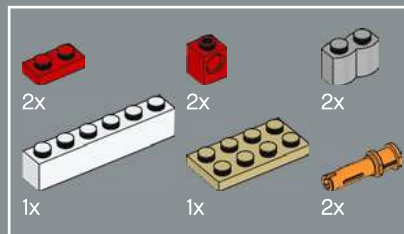
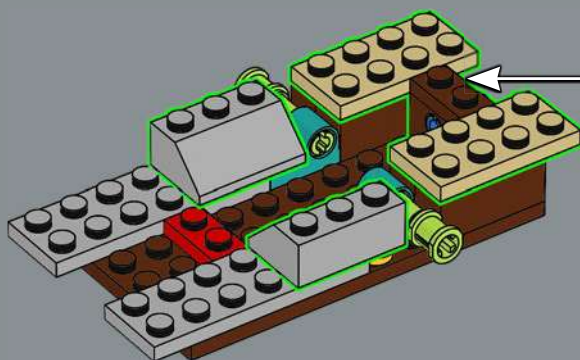
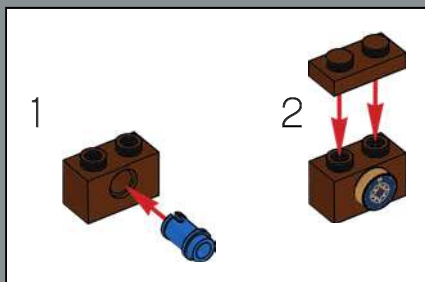

275

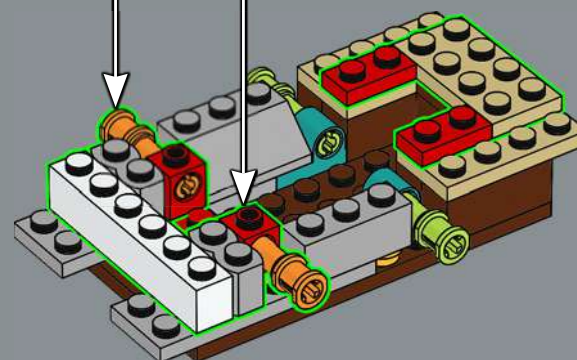
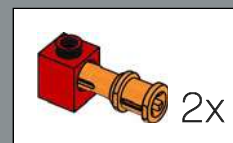



276

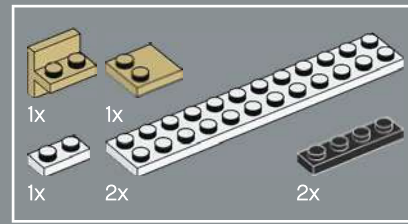
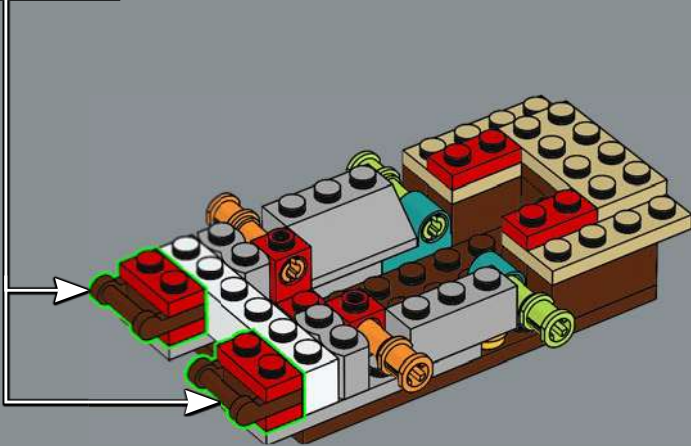
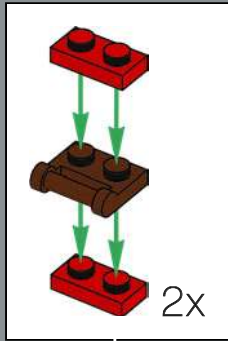

277

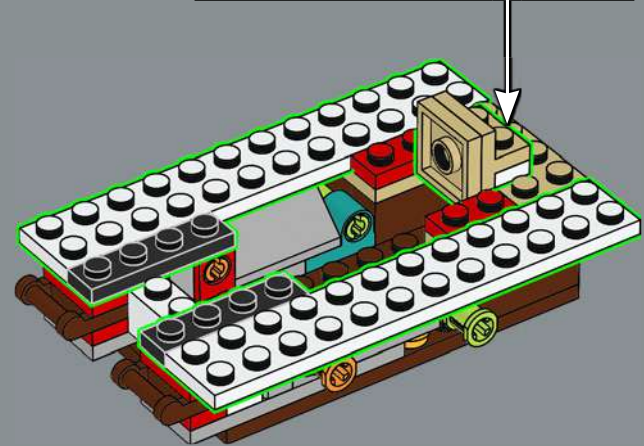
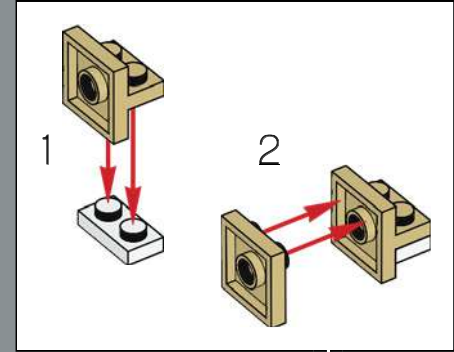

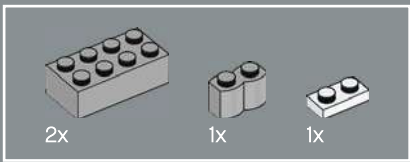

278

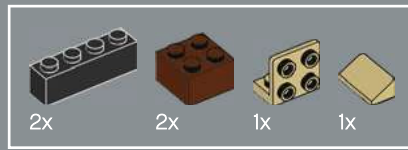
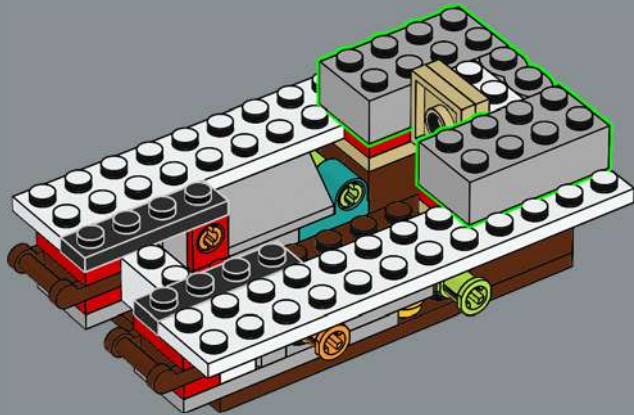

279

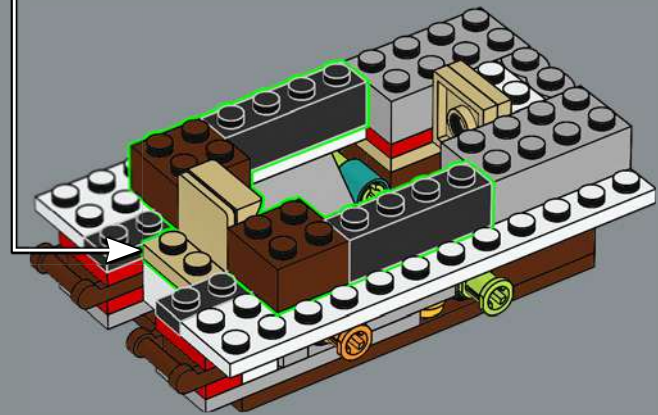
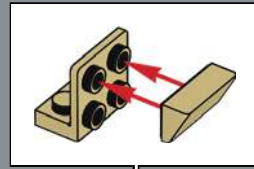

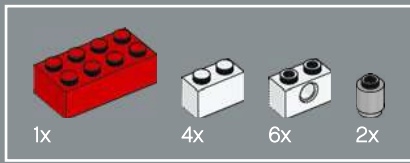

280

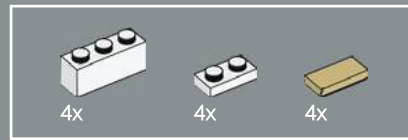
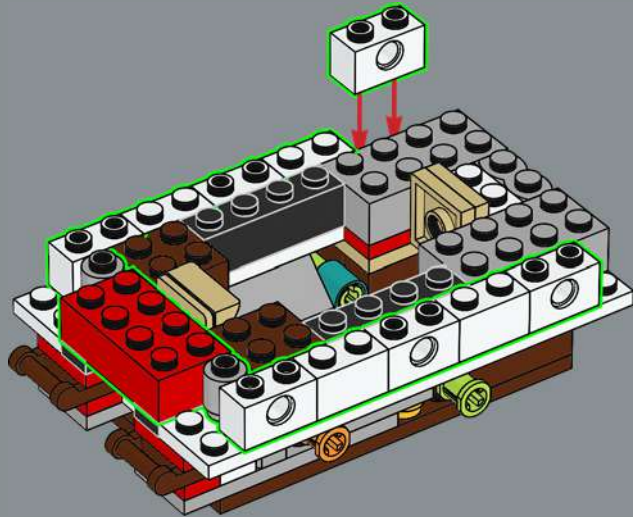

281

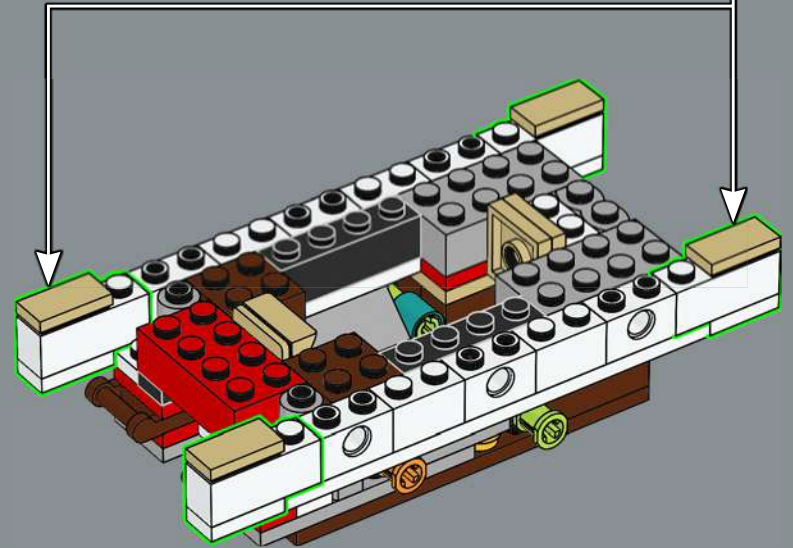
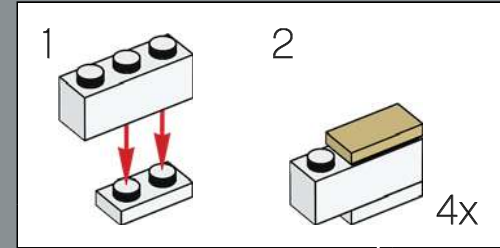

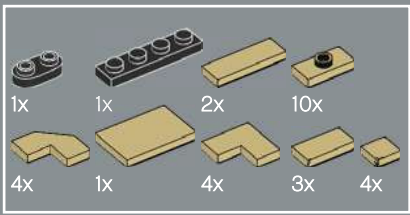

282

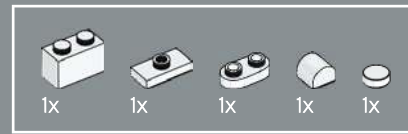
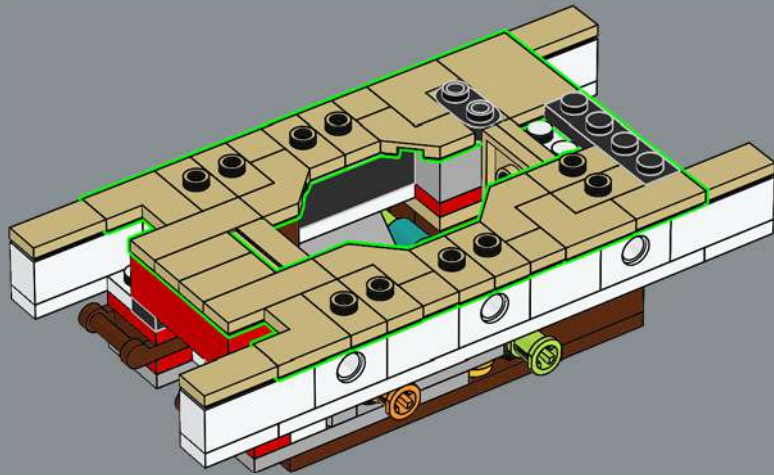

283

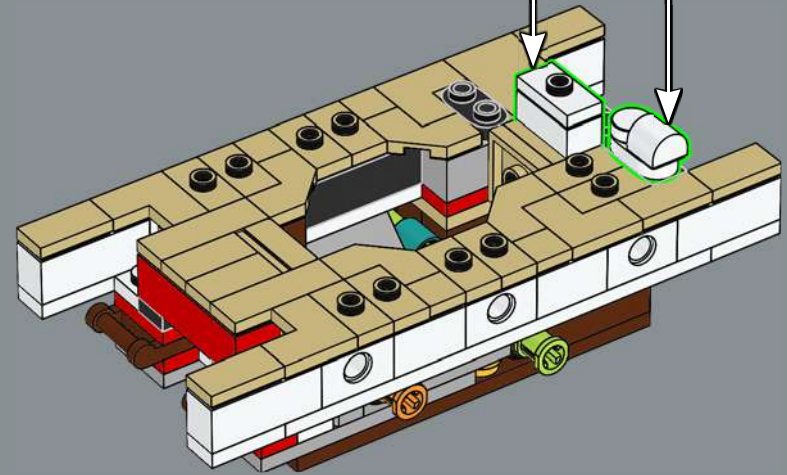
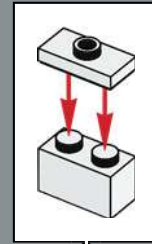
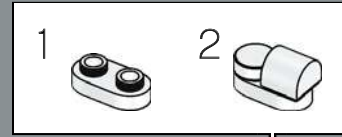

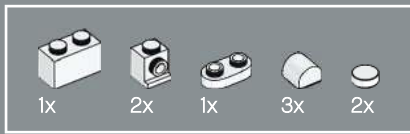

284

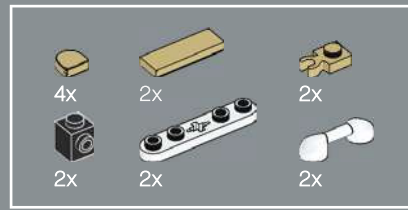
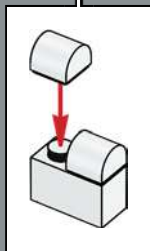
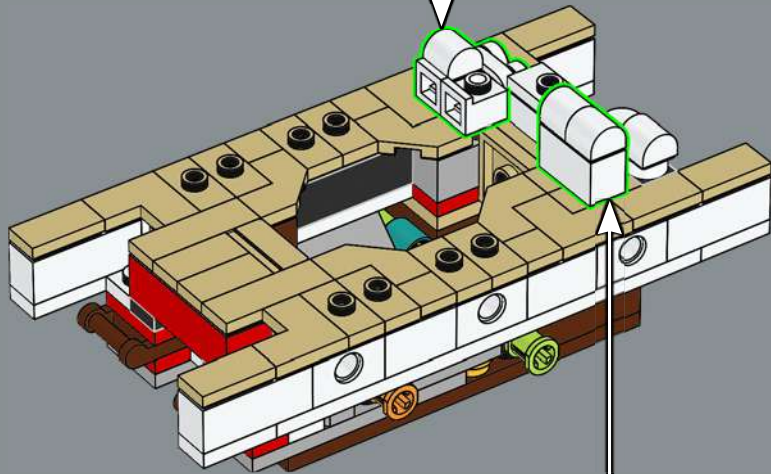
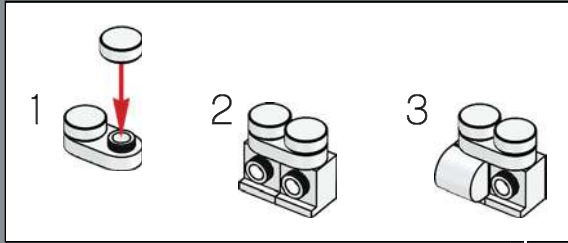

285

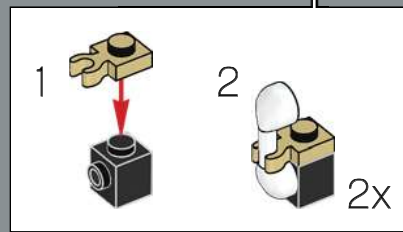
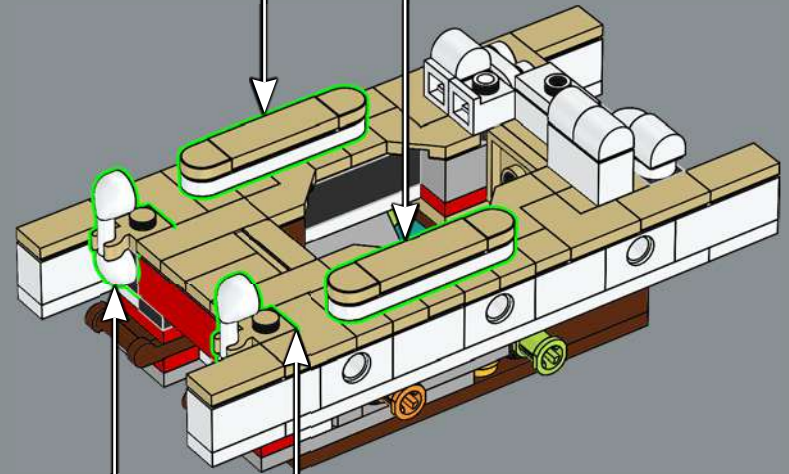
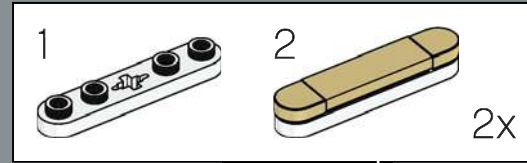

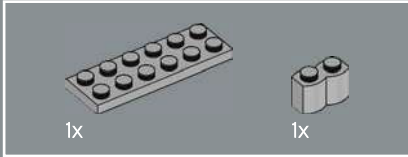
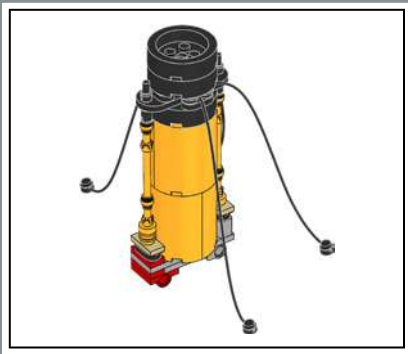

286

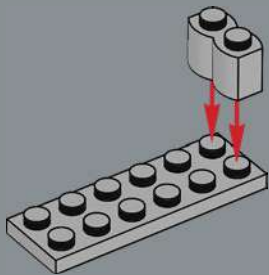

287

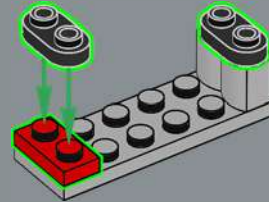

288

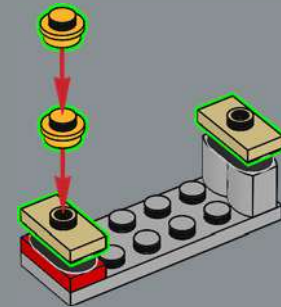

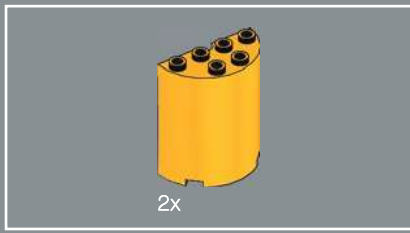

289

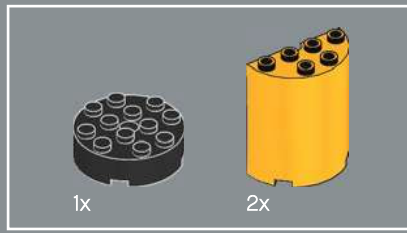
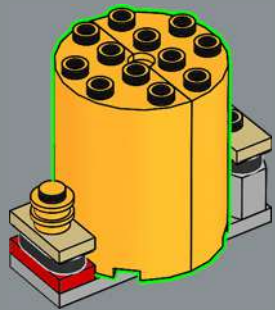

290

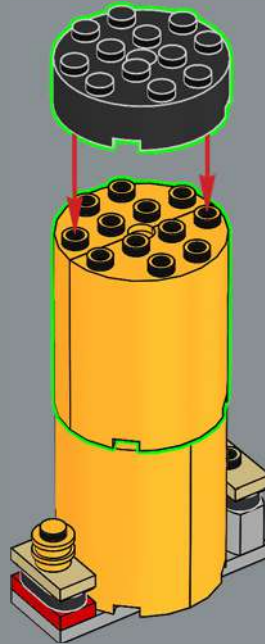

291

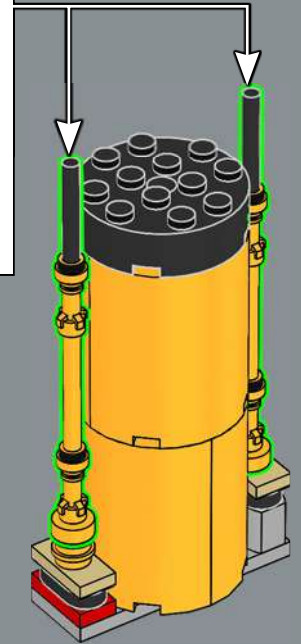
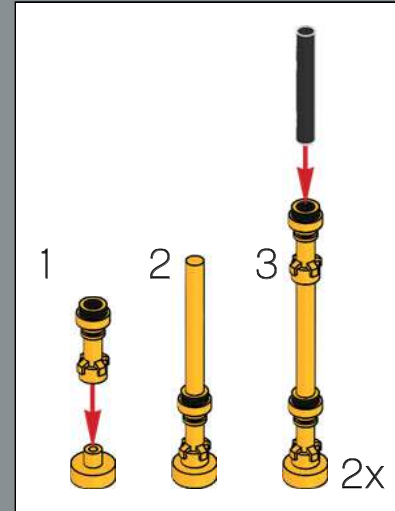

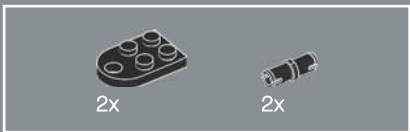

292

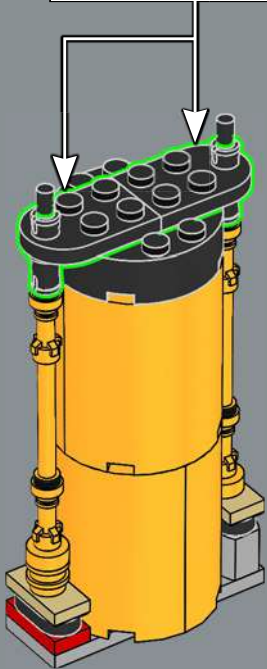
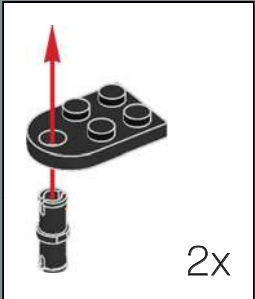

293

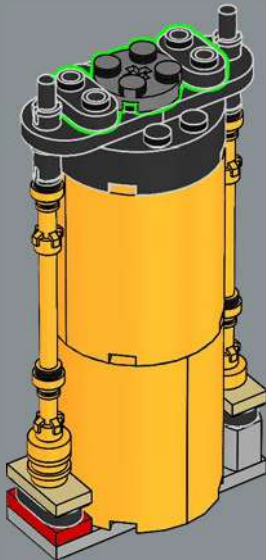

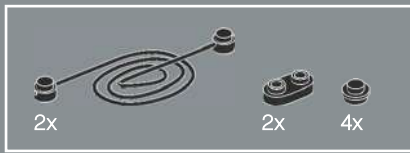

294

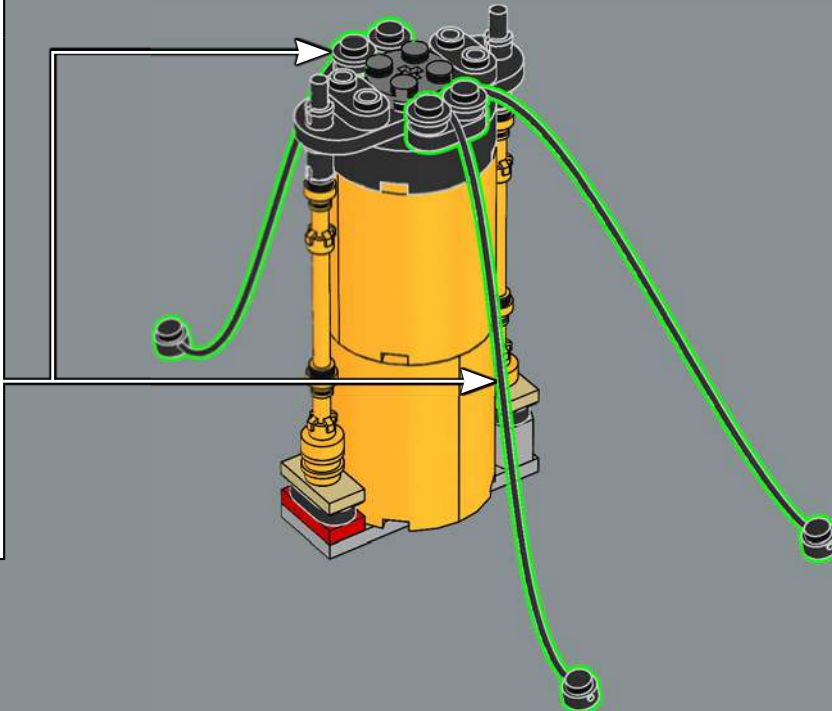
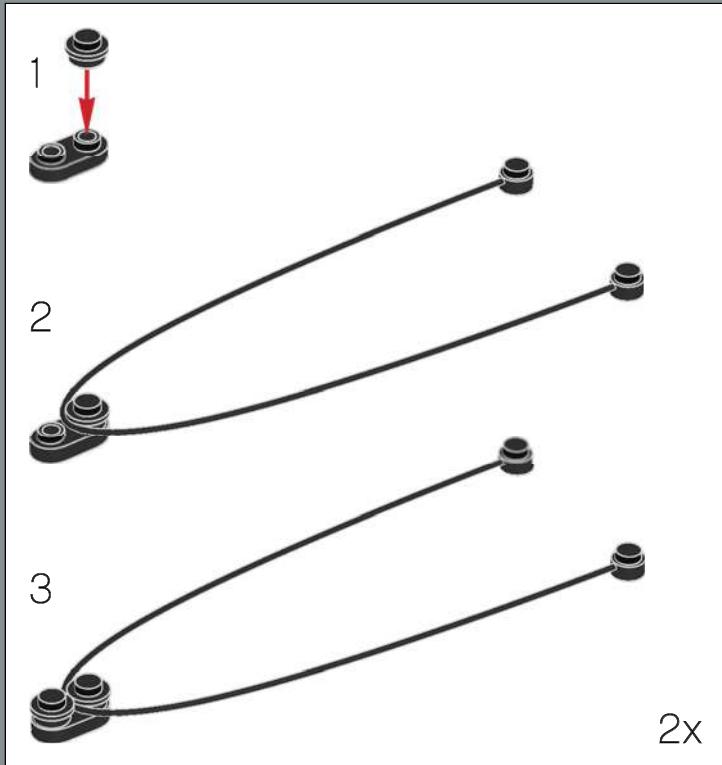

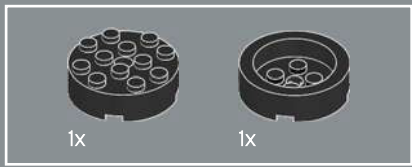

295

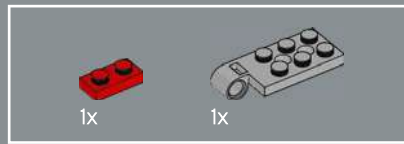
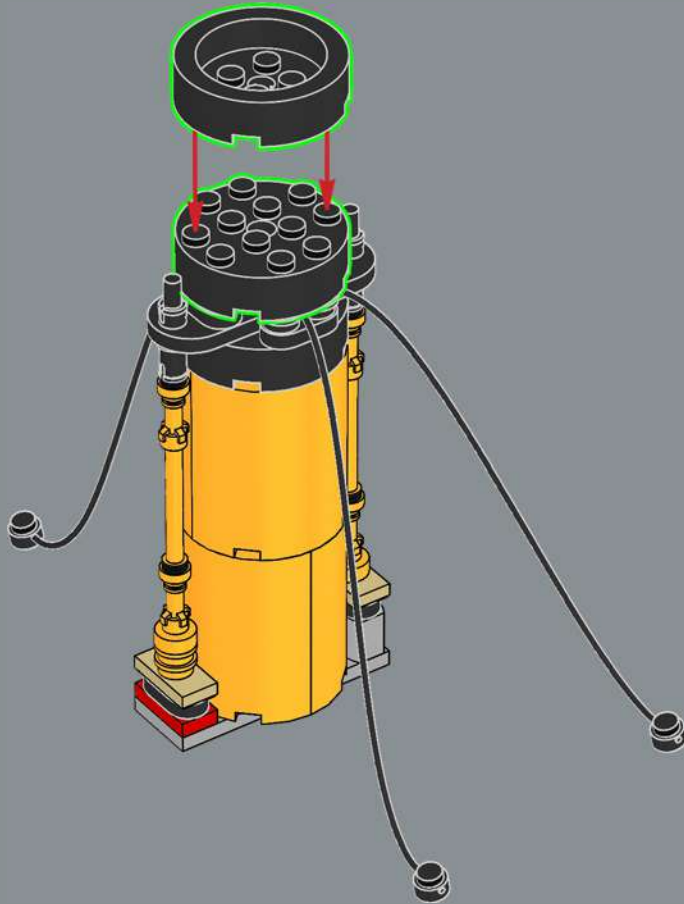

296

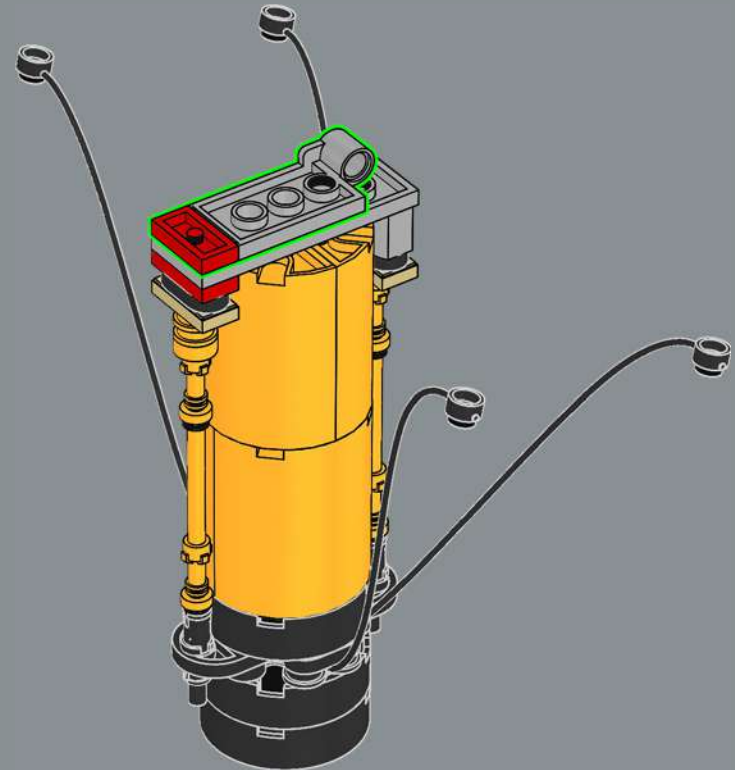

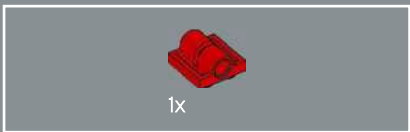

297

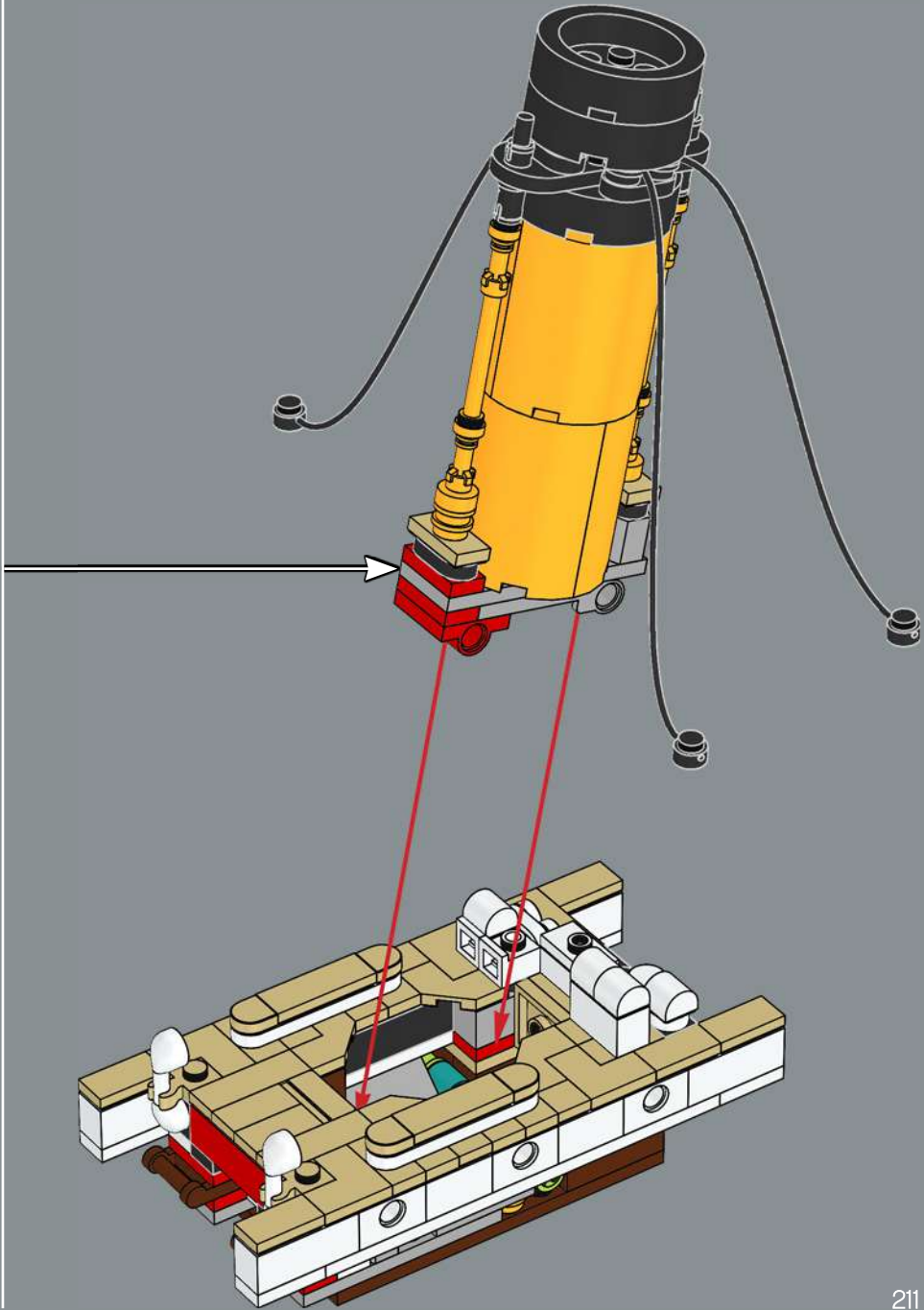
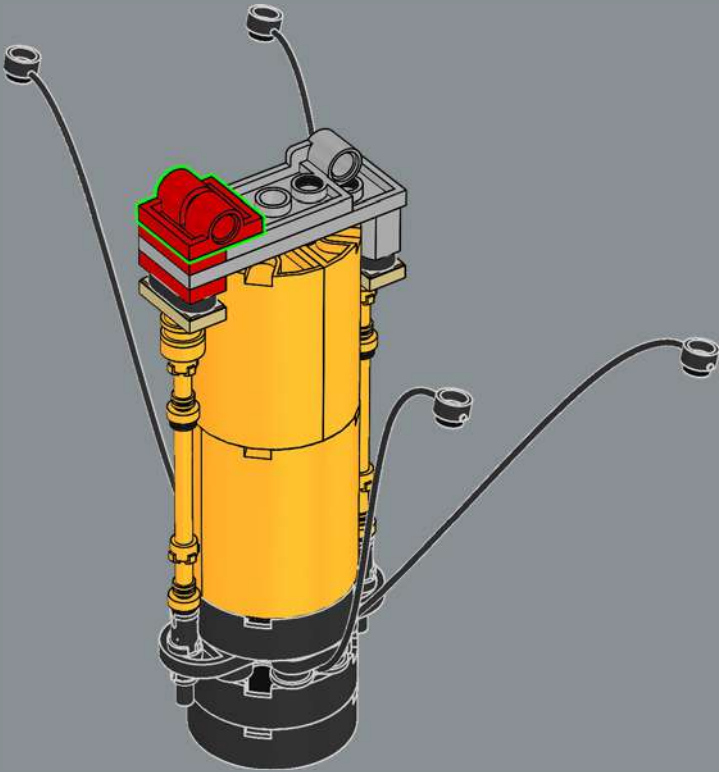

The ship's communication room contained one of the most powerful transmitters in the world, guaranteed to broadcast over a radius of 563 km (350 miles).

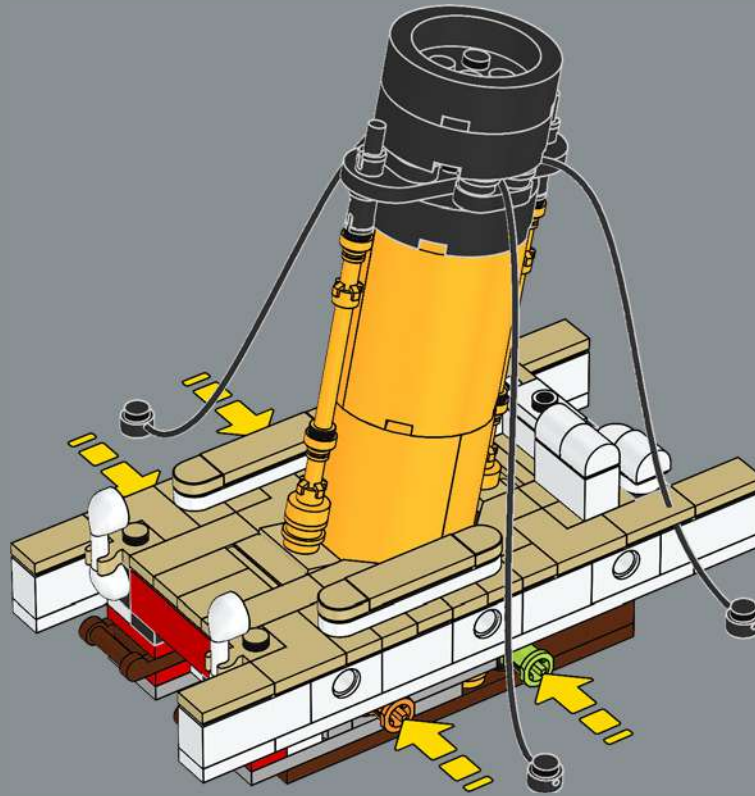

299

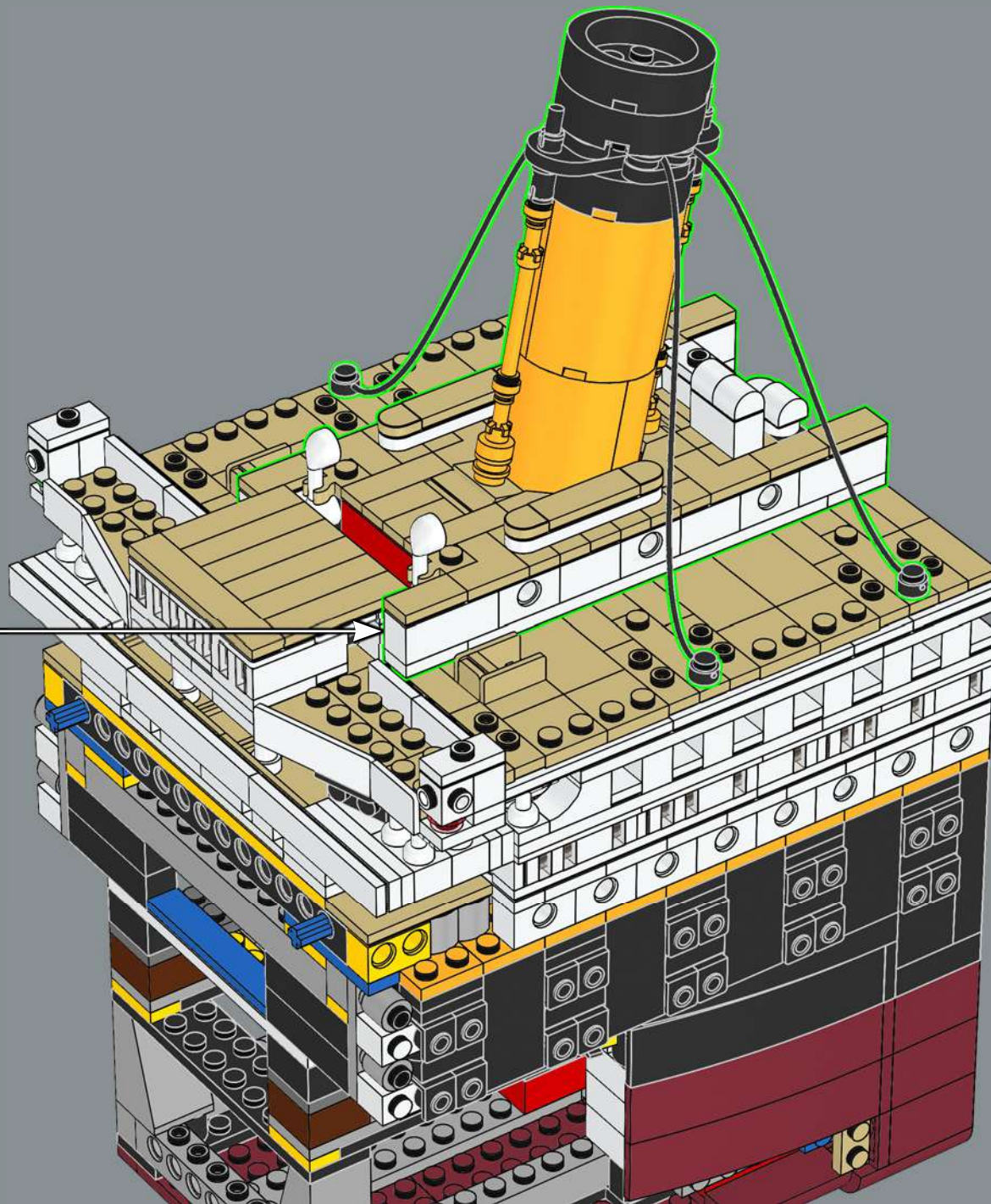

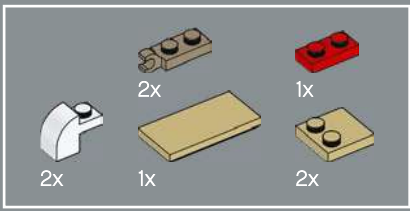

300

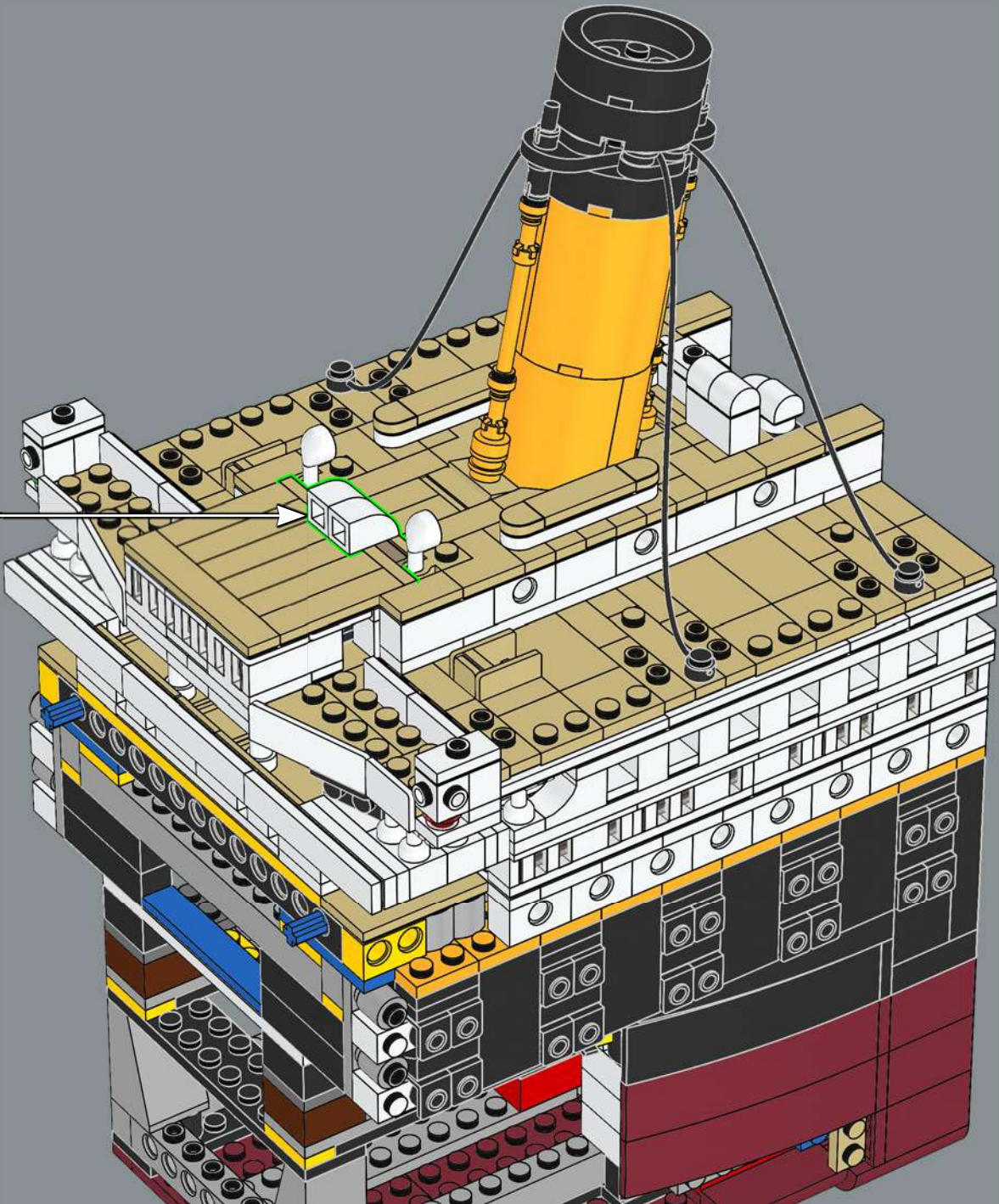
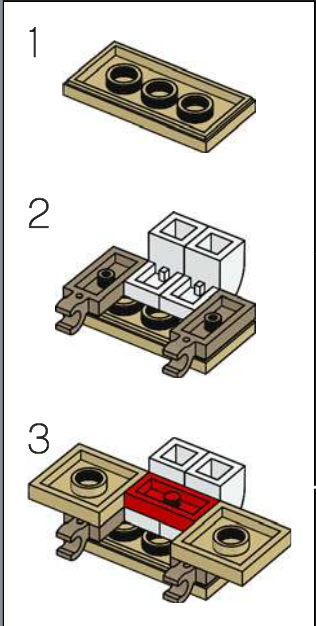

301

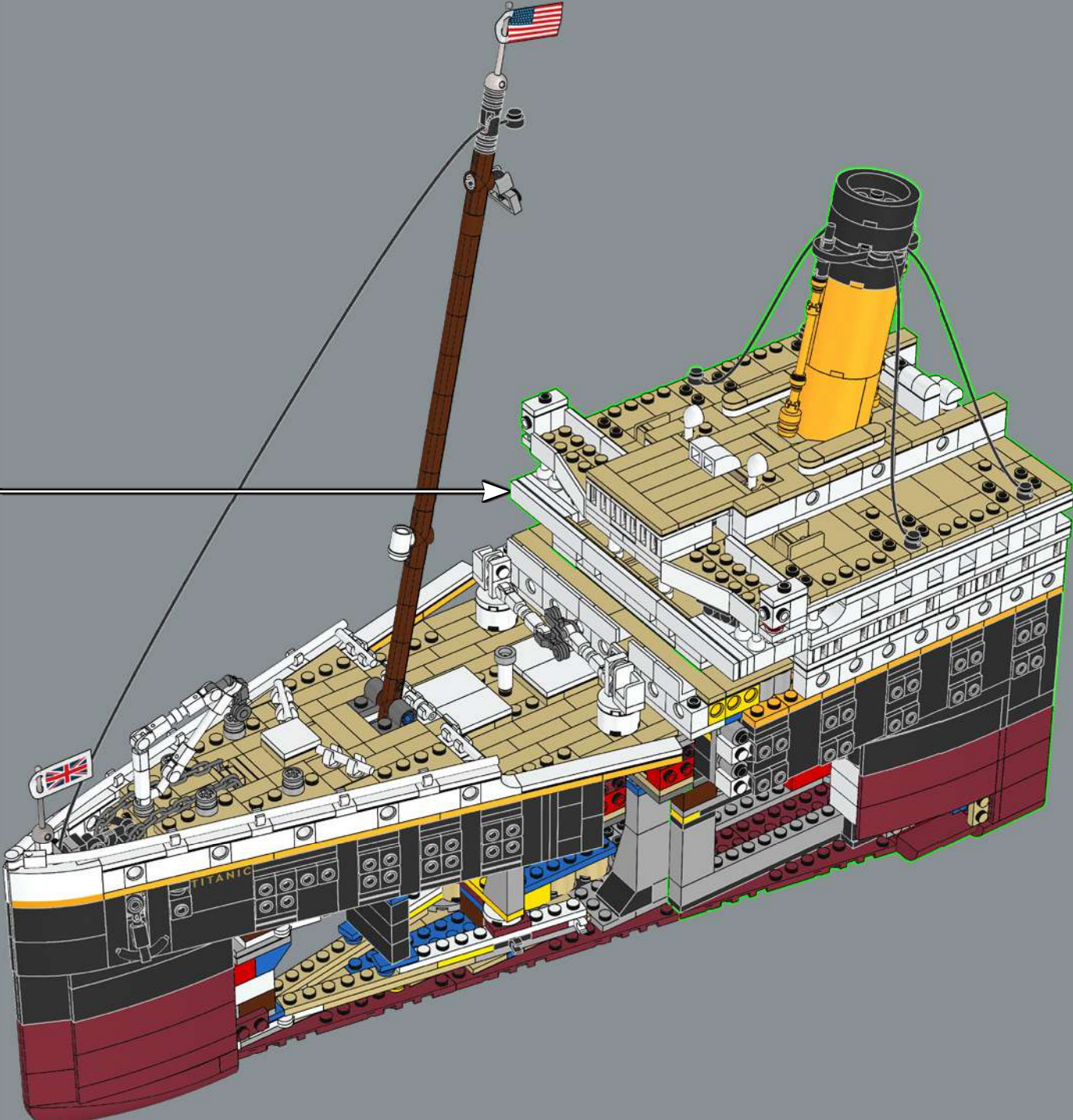

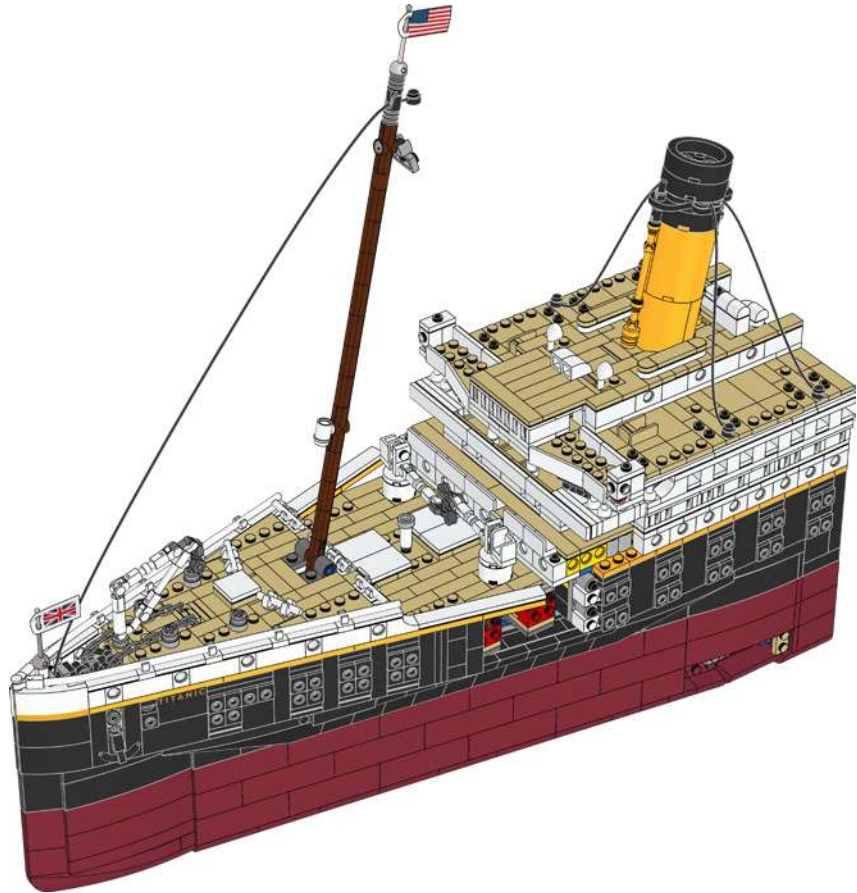
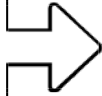

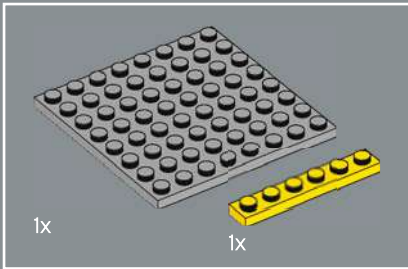
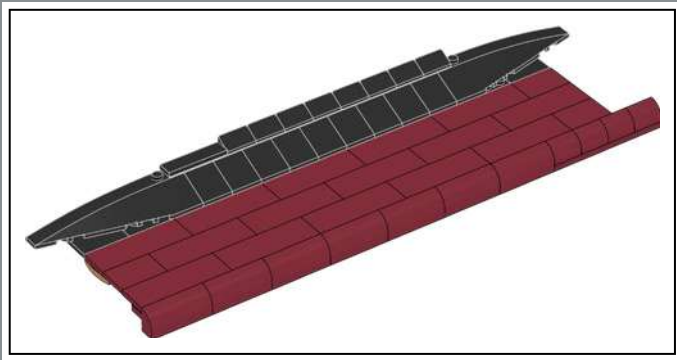

302

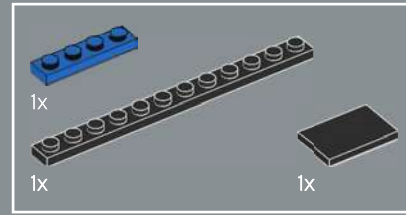
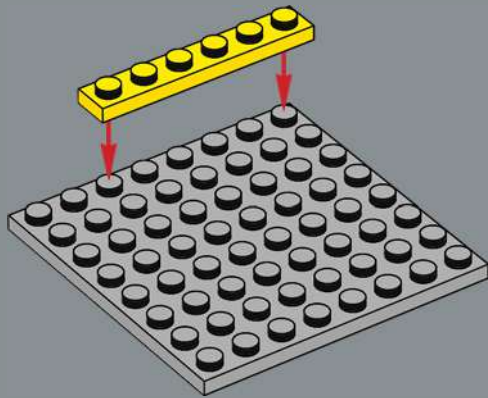

303

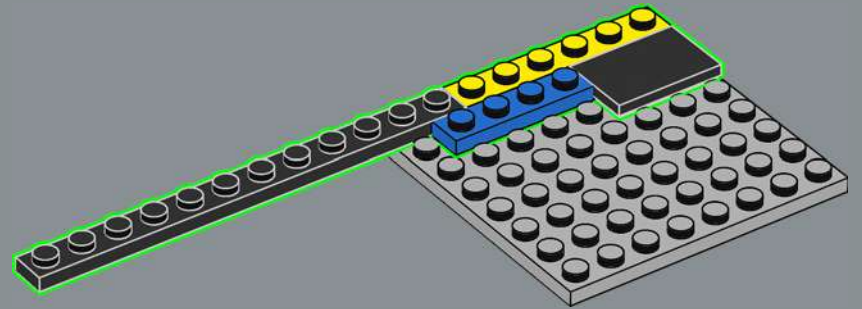

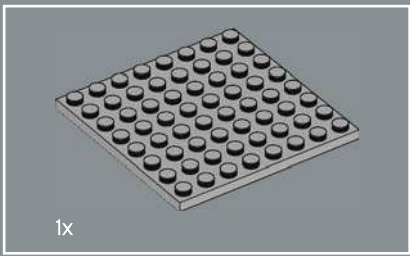

304

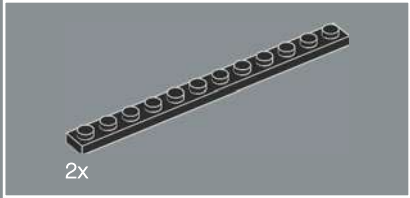
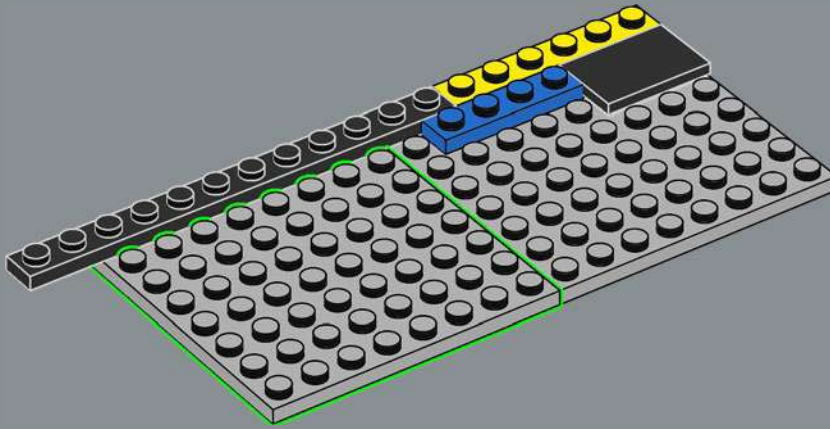

305

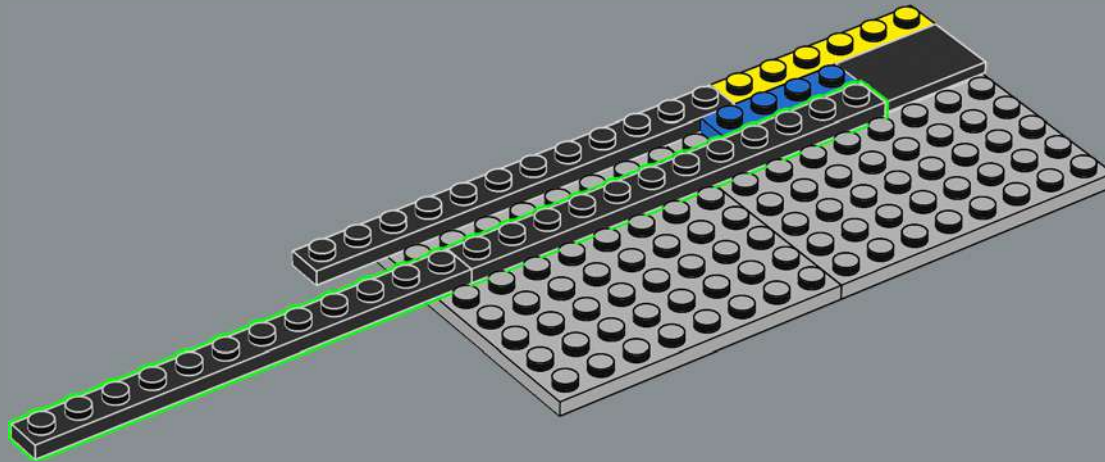

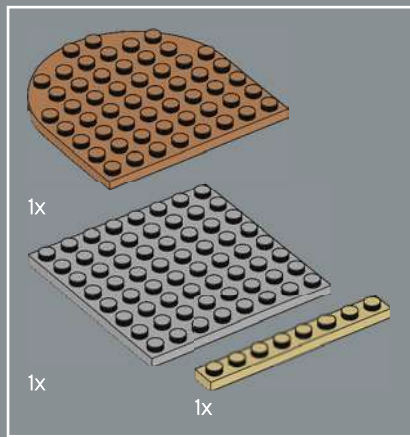

306

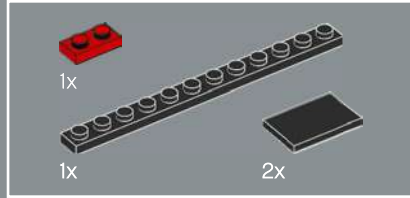
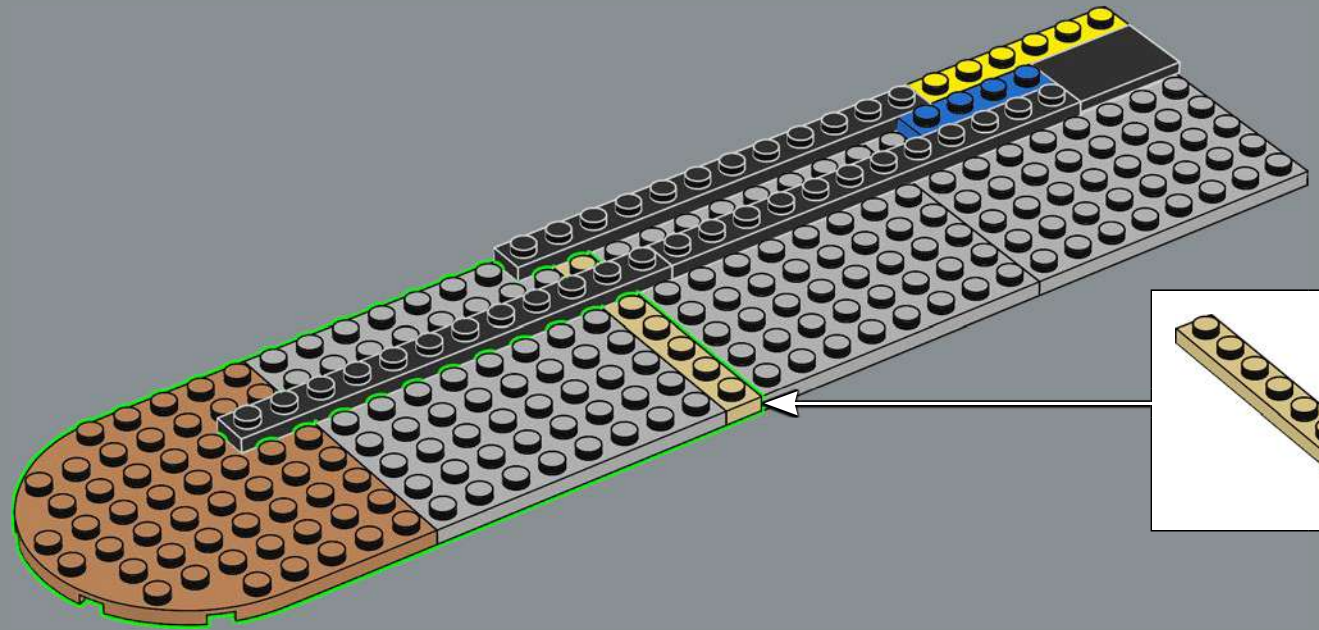

307

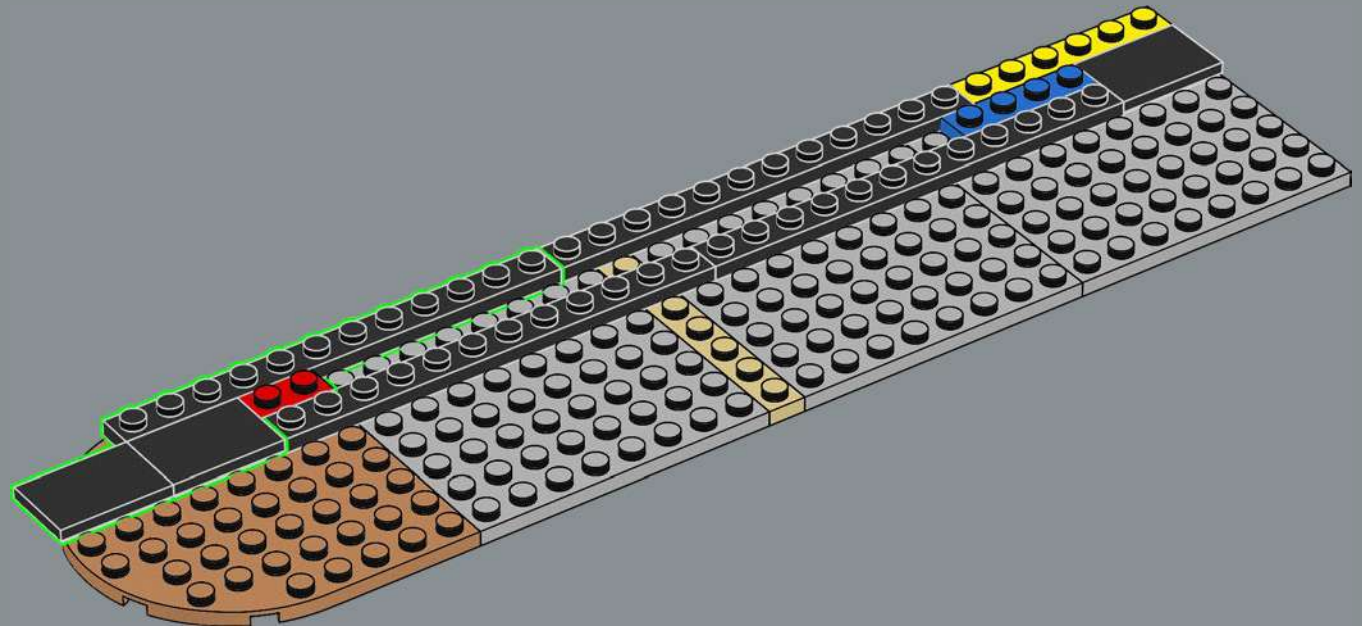

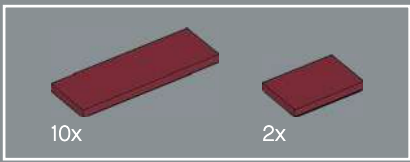

308

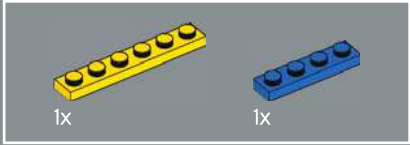
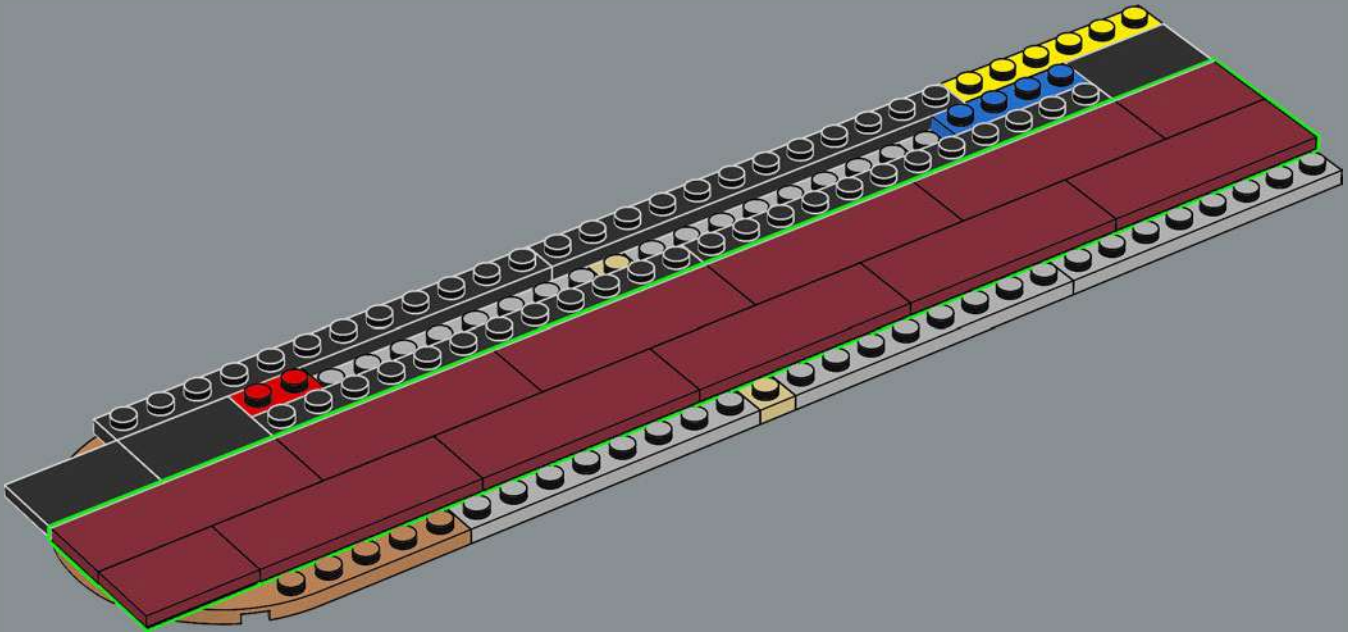

309

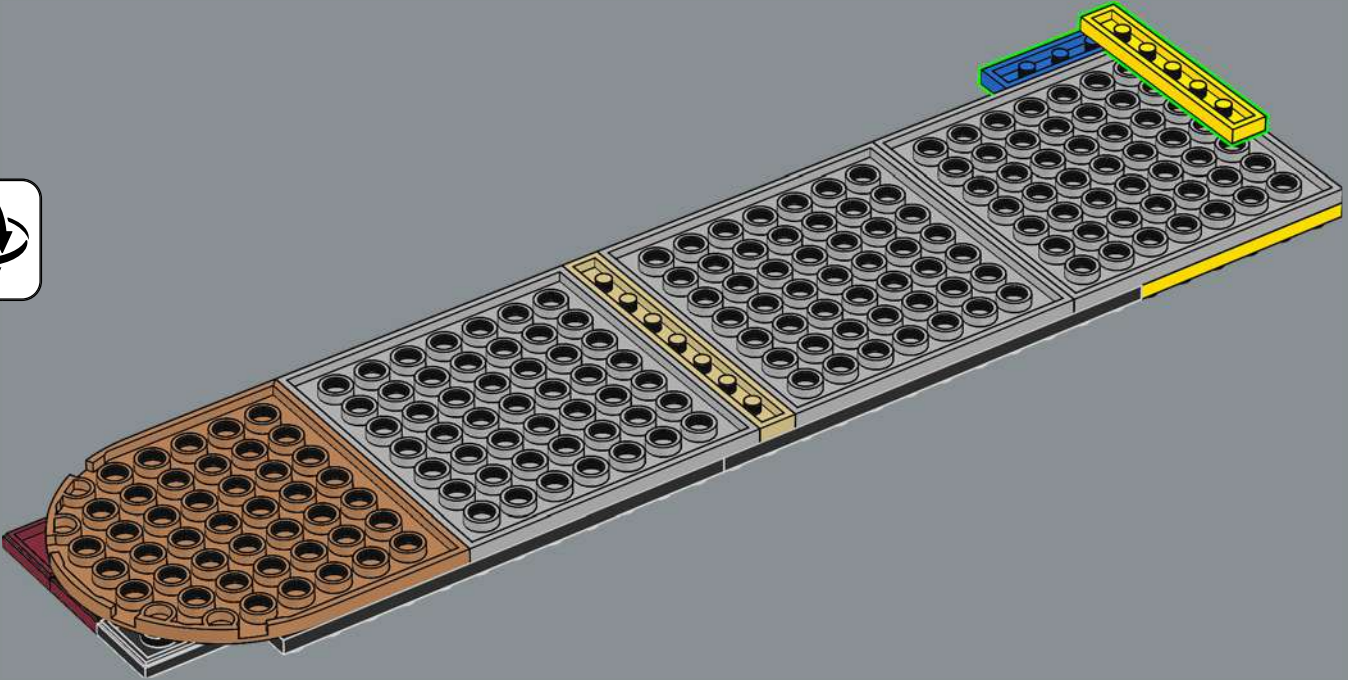

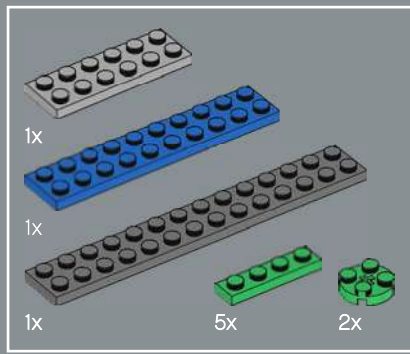

310

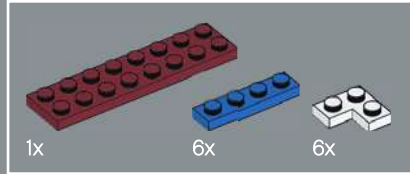
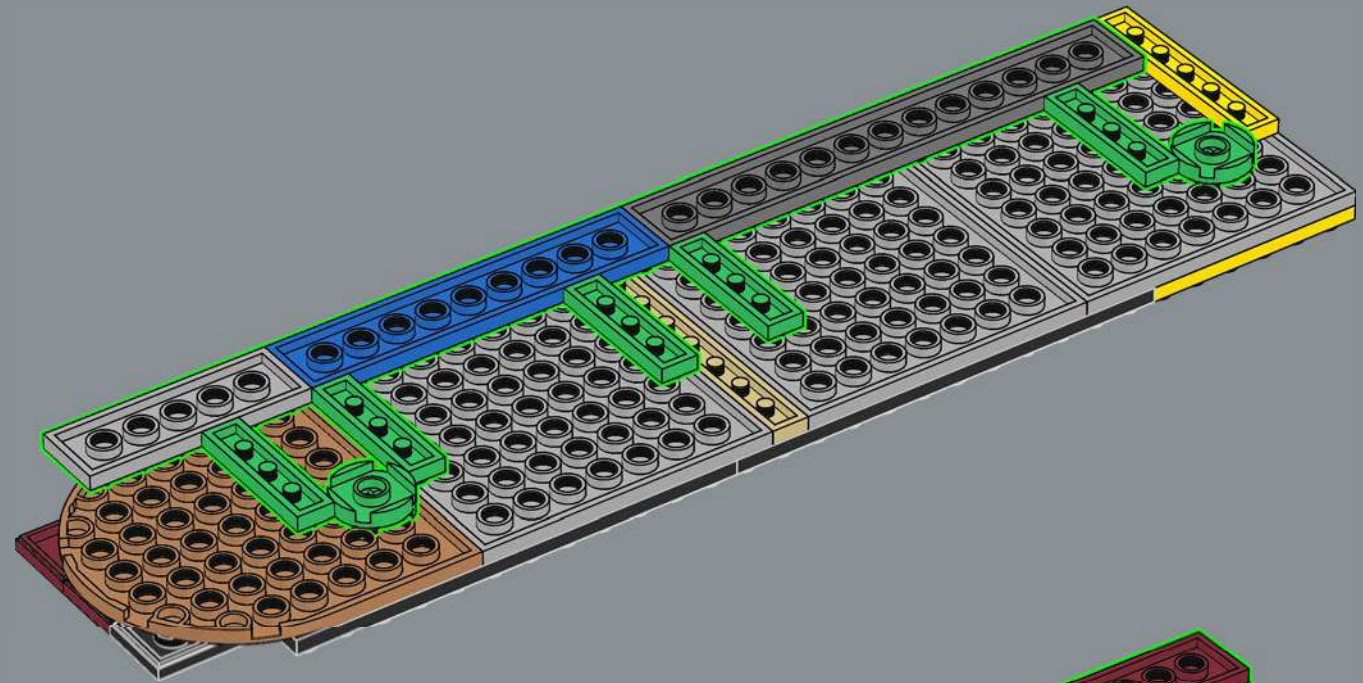

311

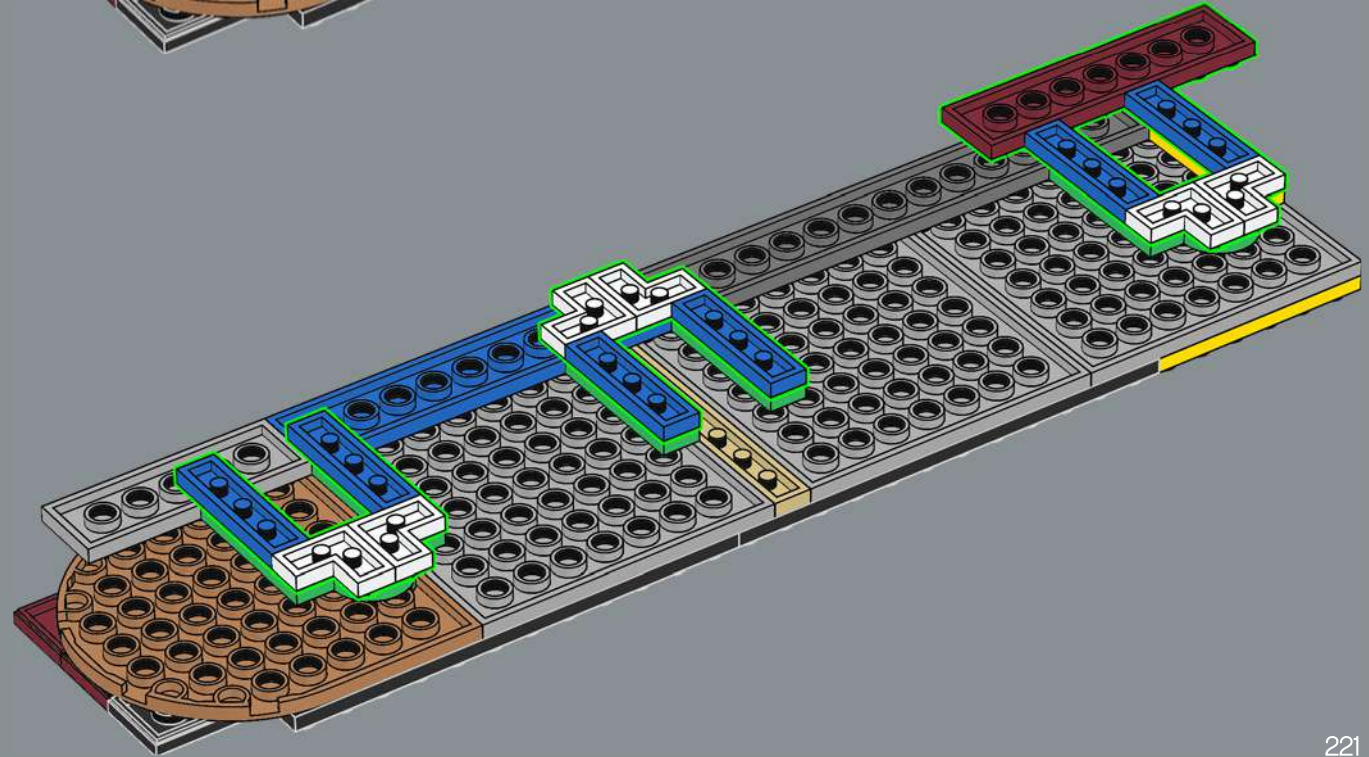

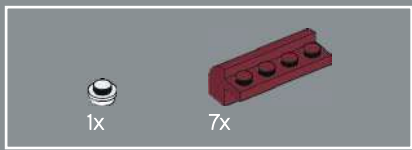

312

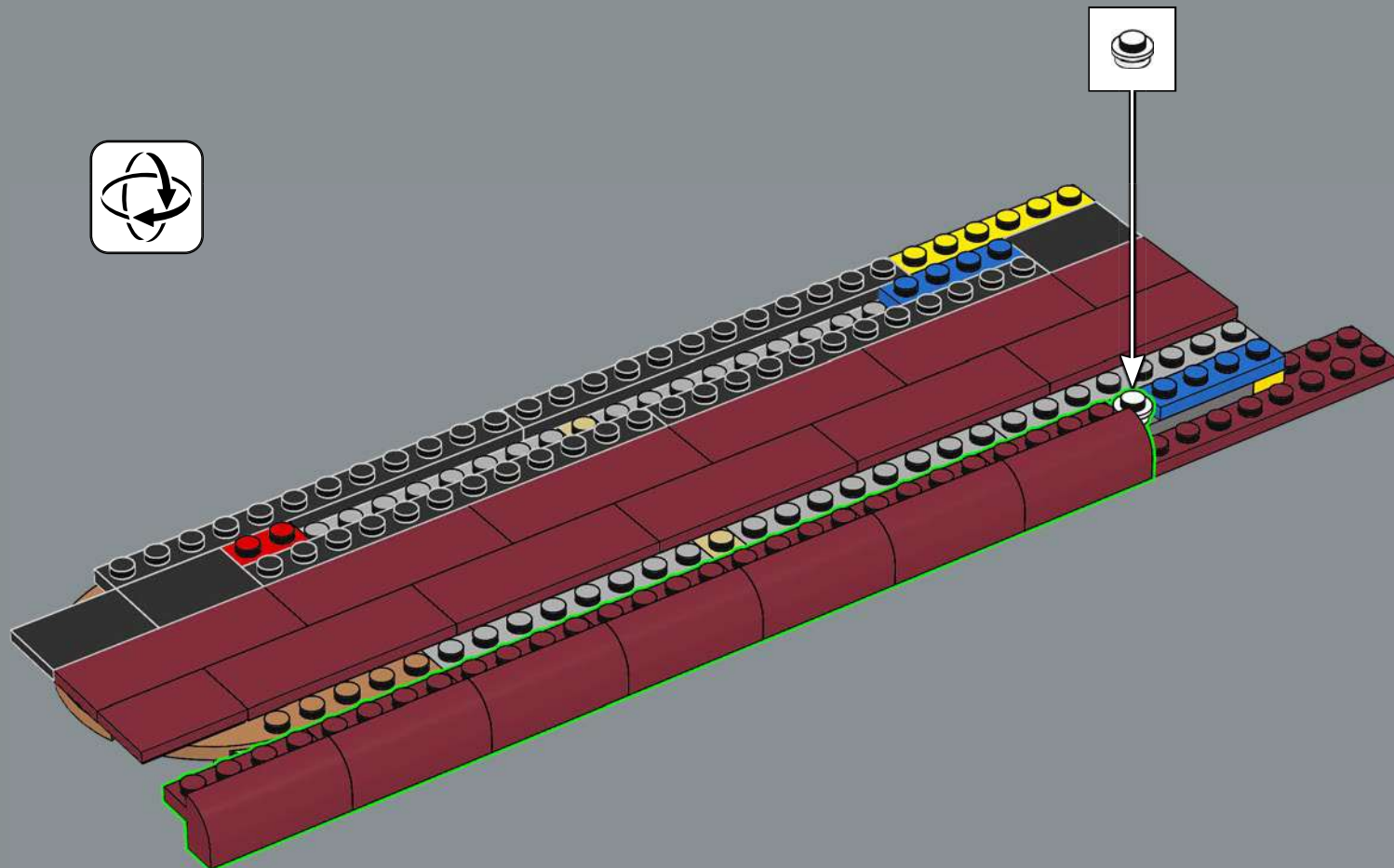

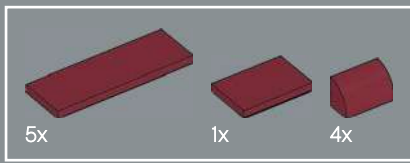

313

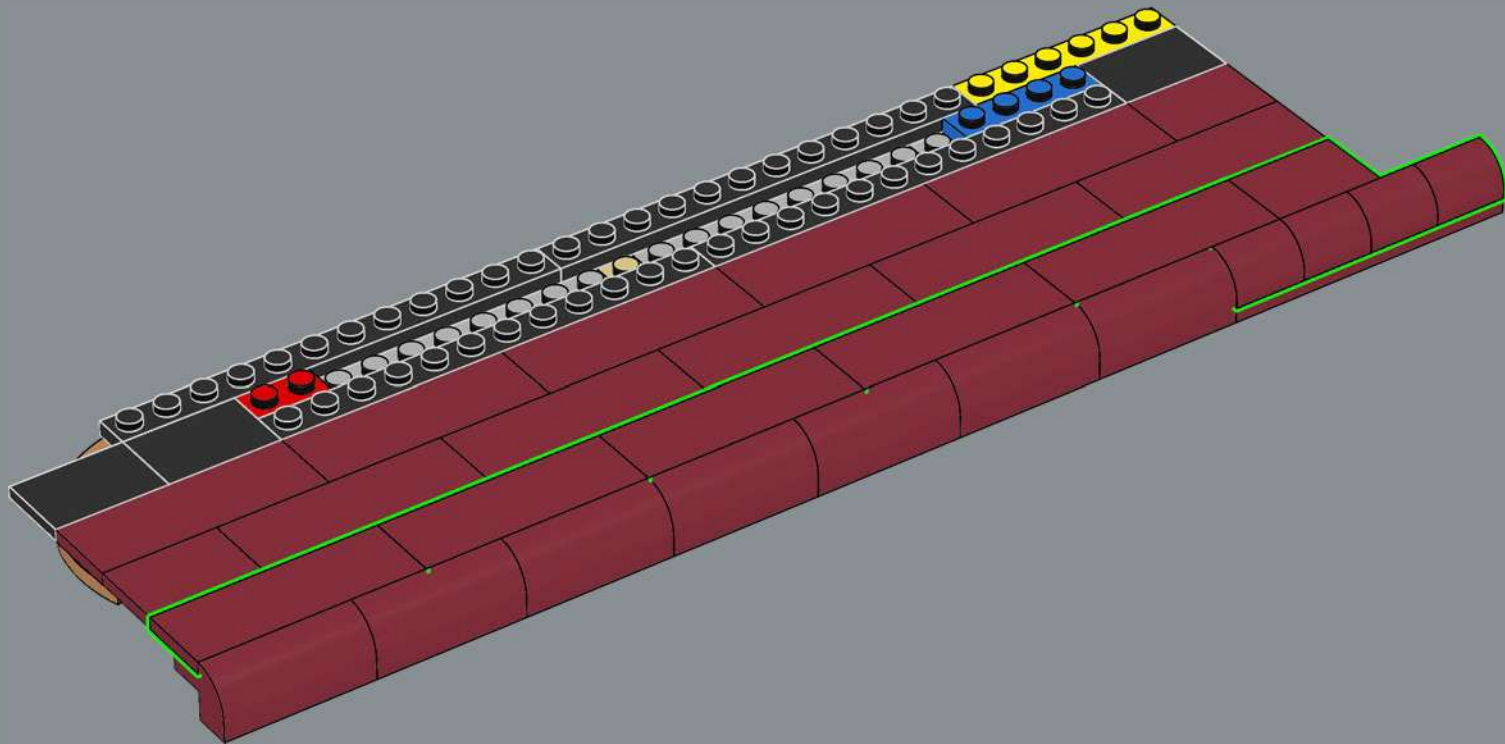



314

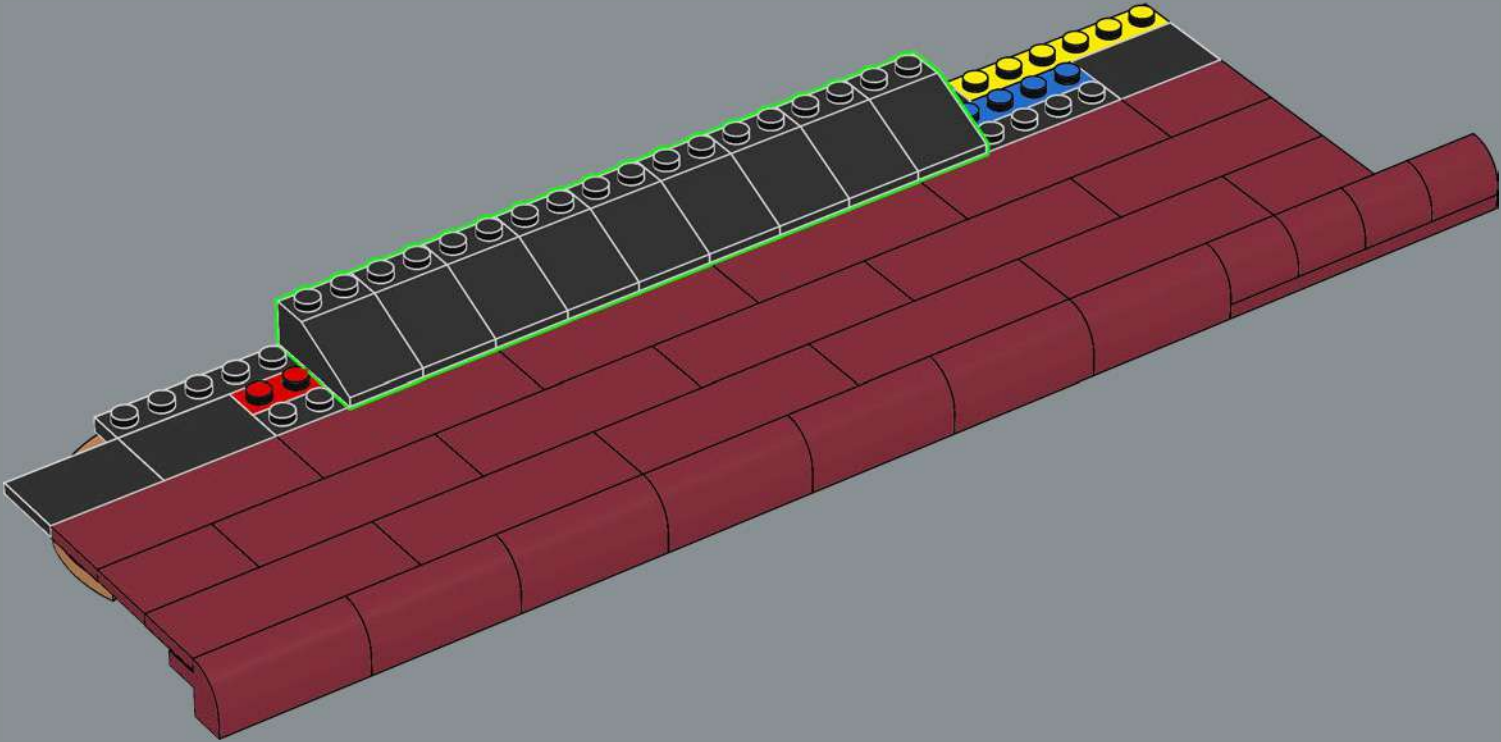

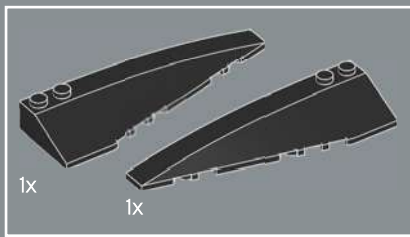

315

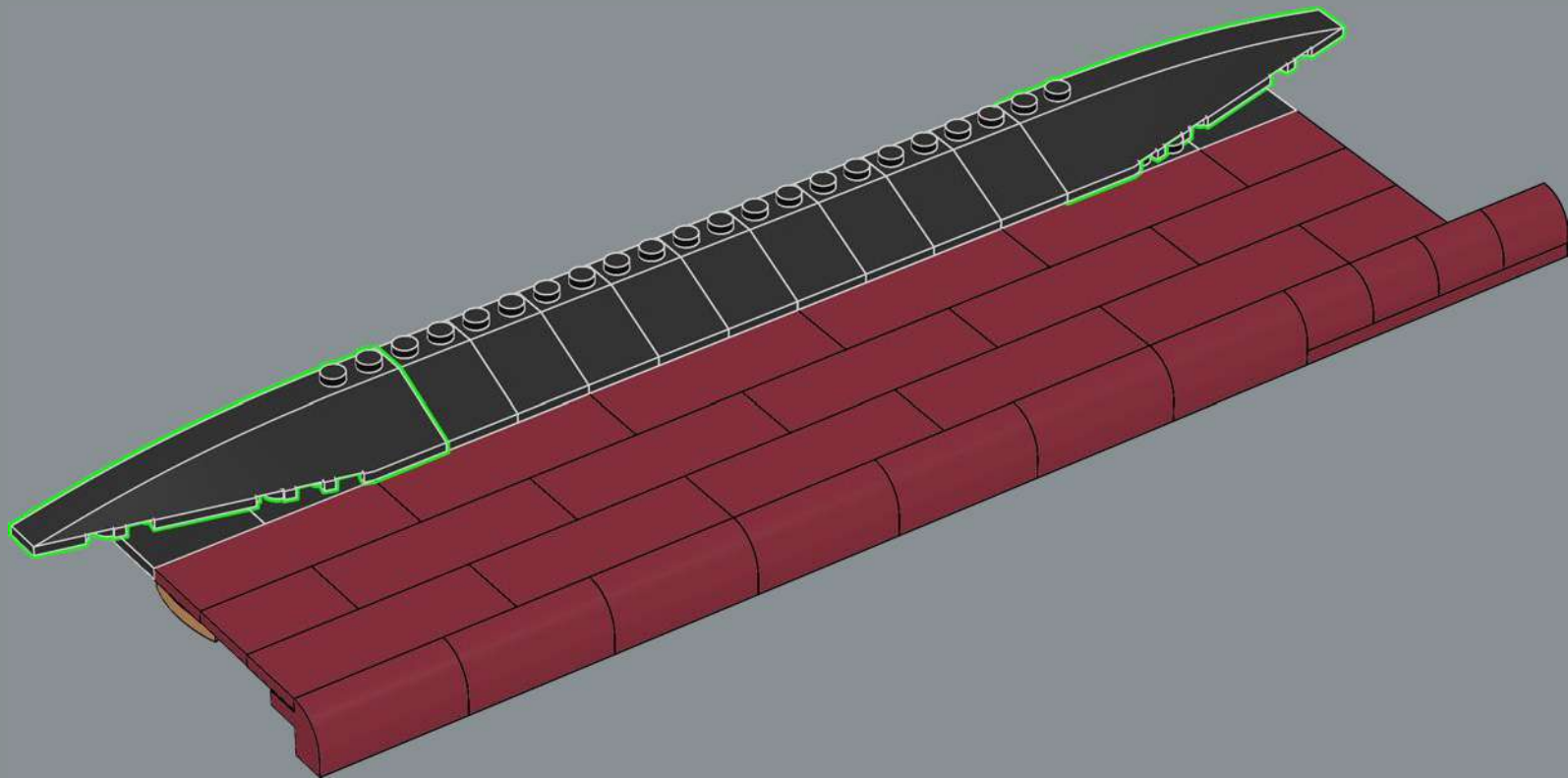

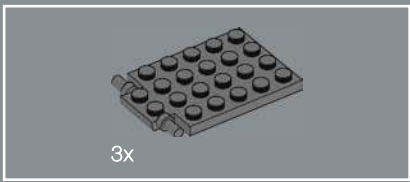

316

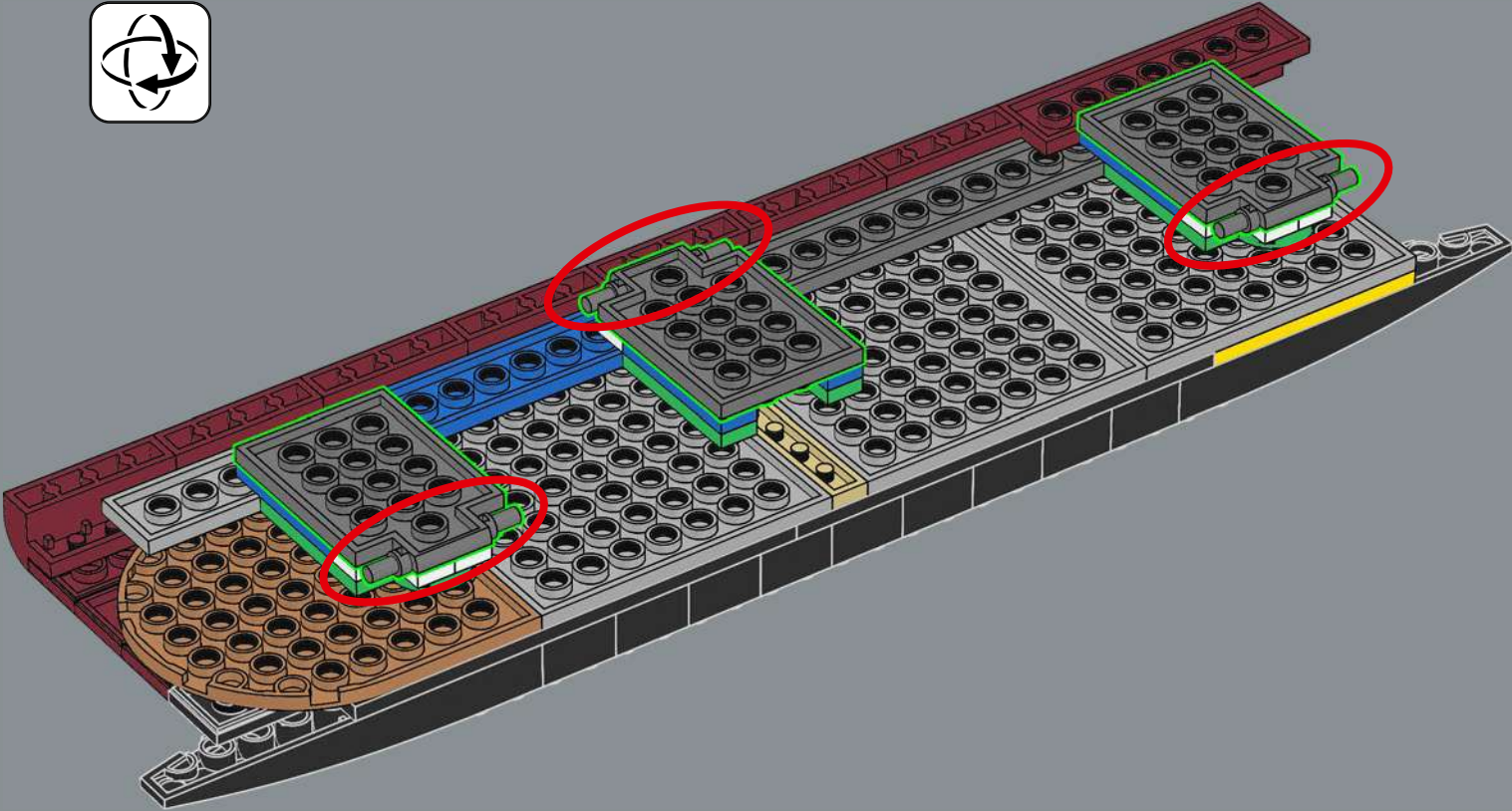



317

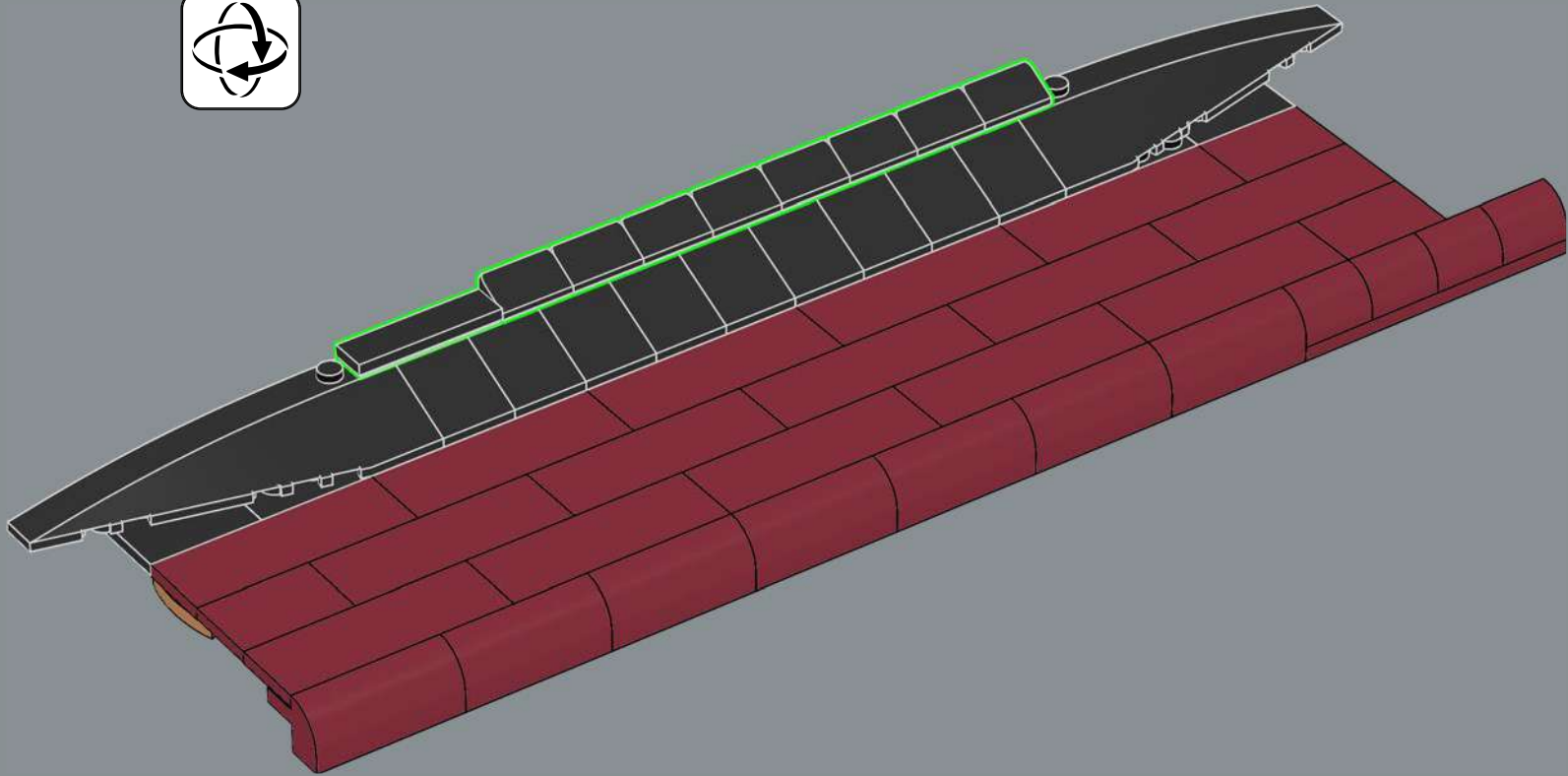

318

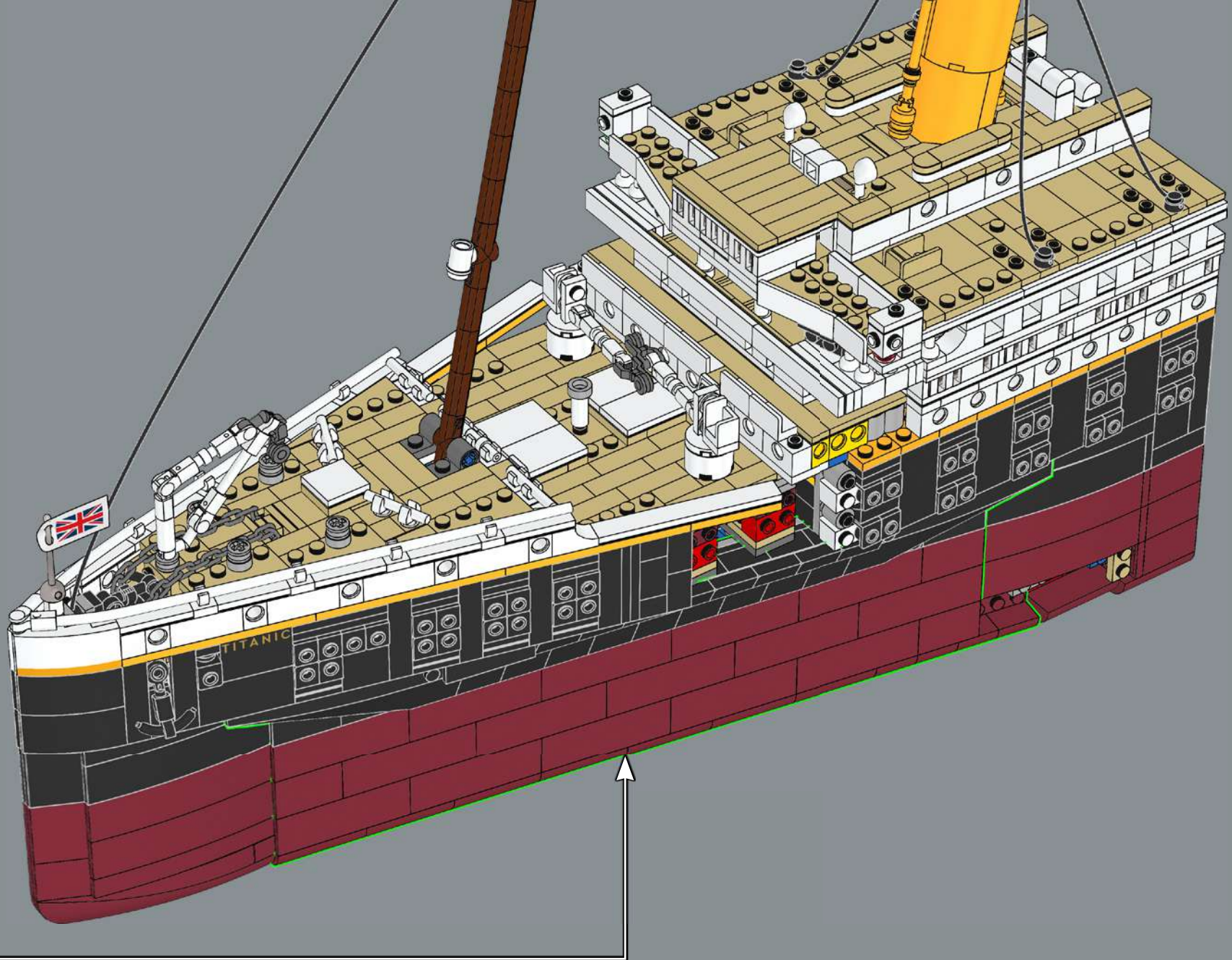

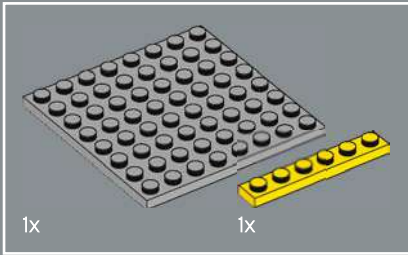
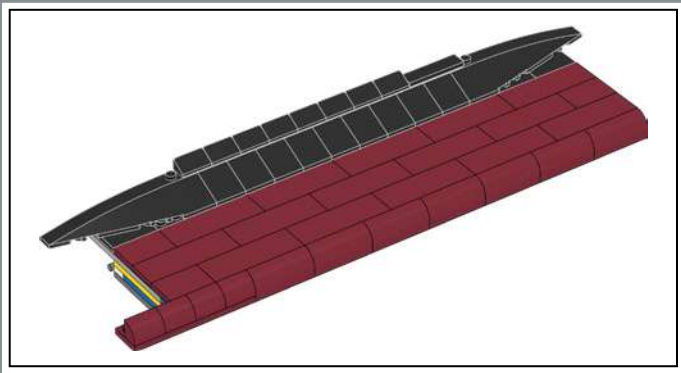

319

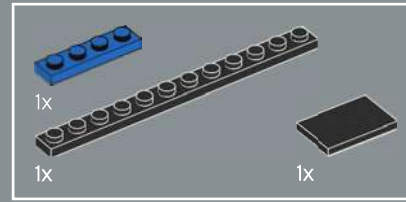
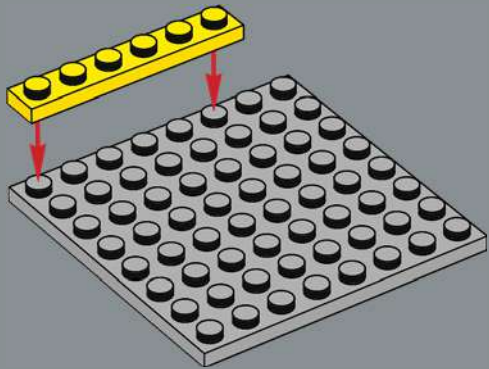

320

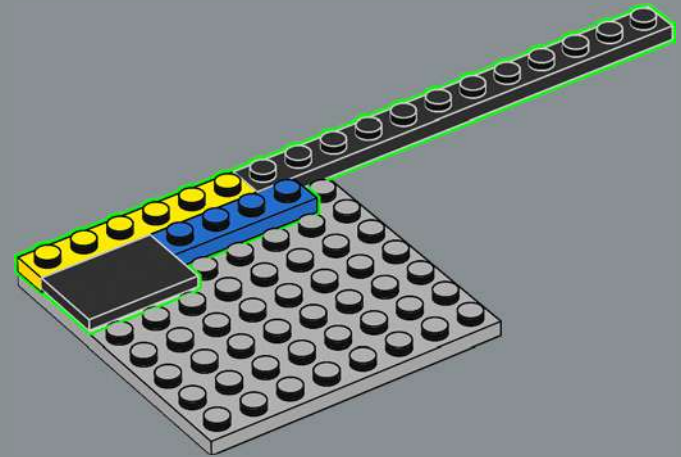

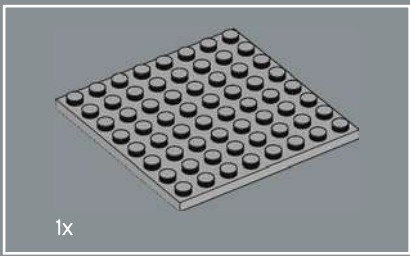

321

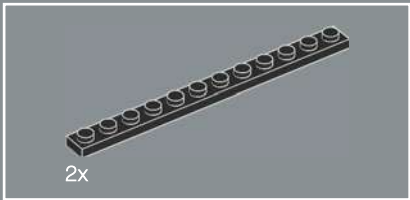
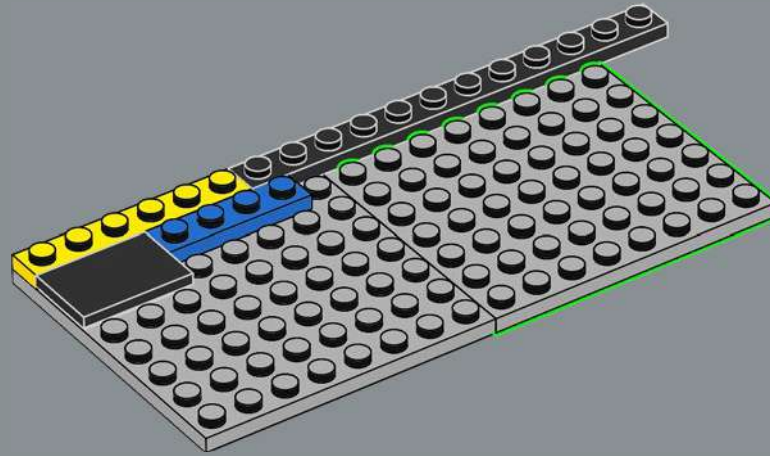

322

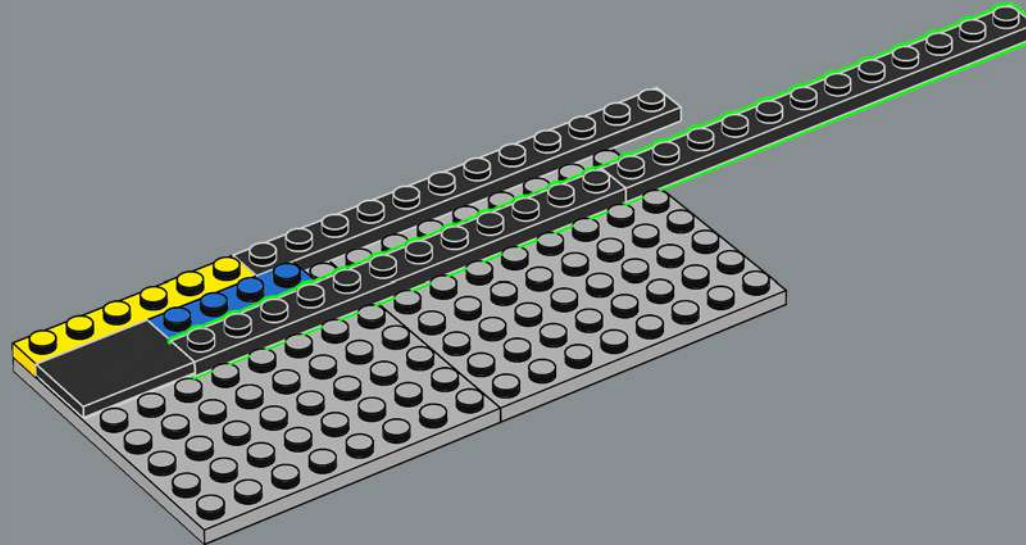

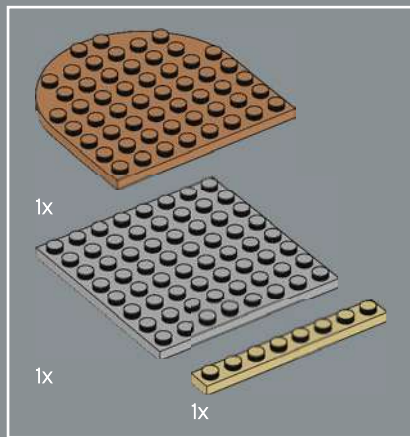

323

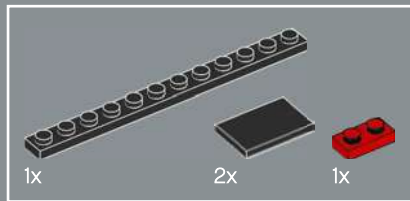
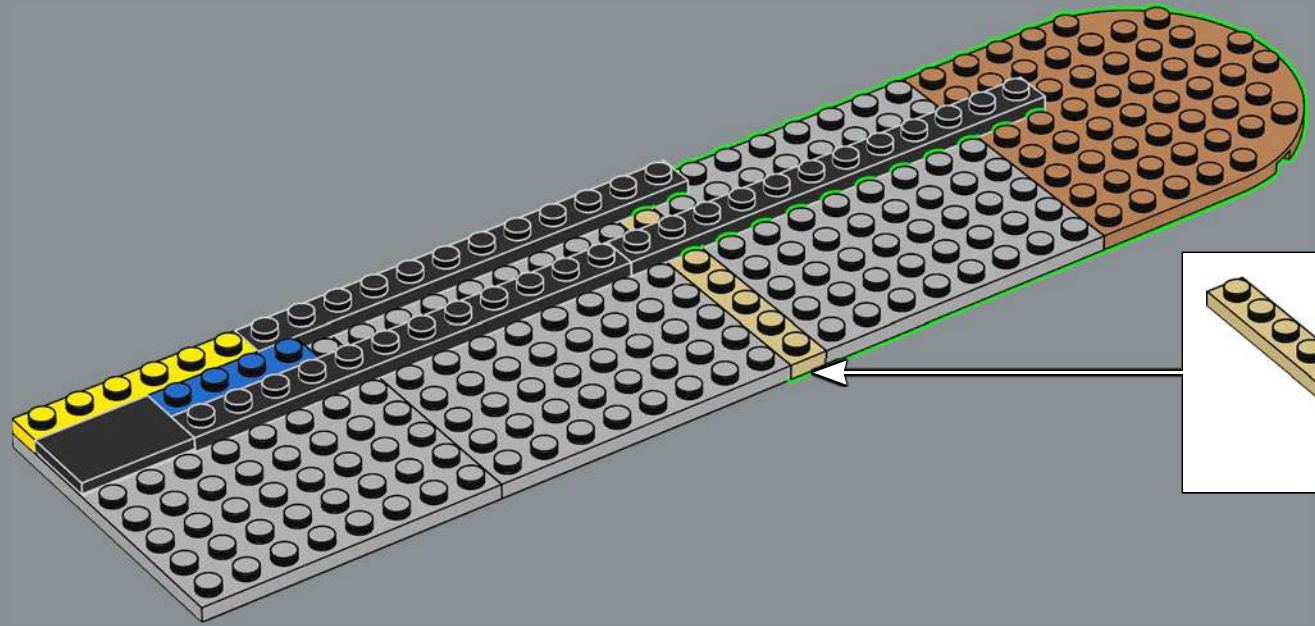

324

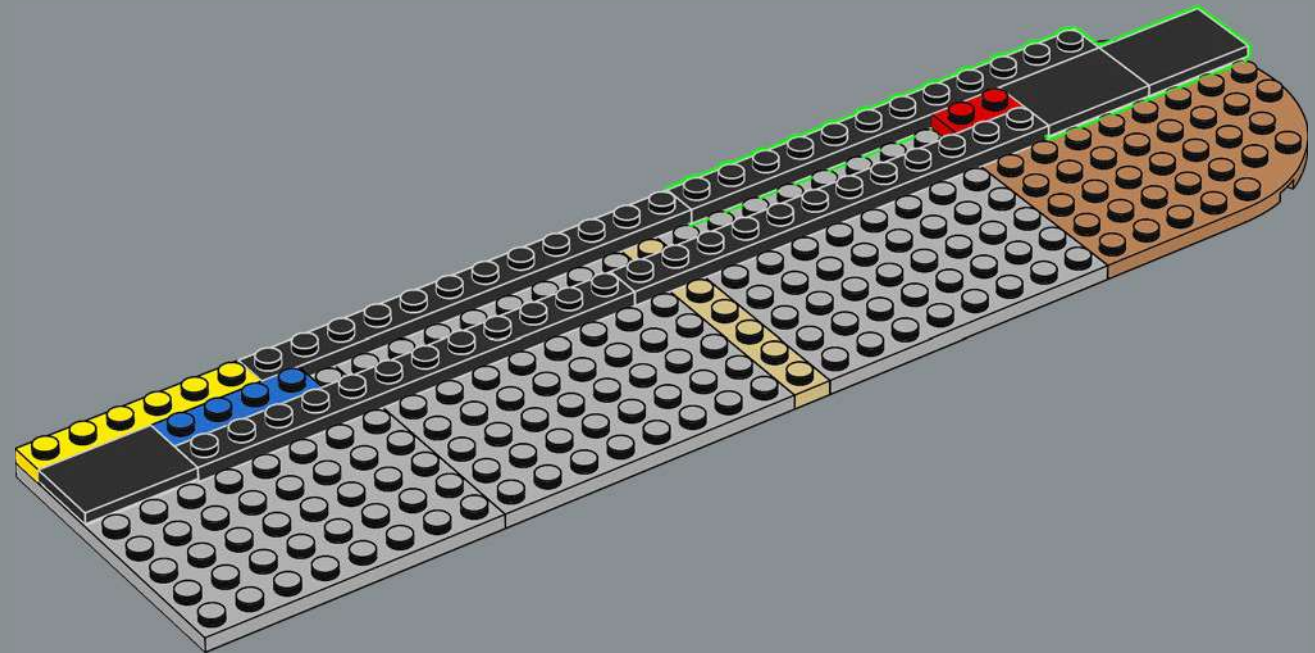

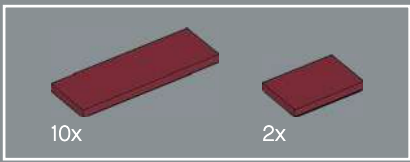

325

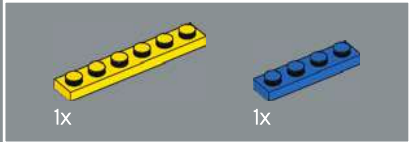
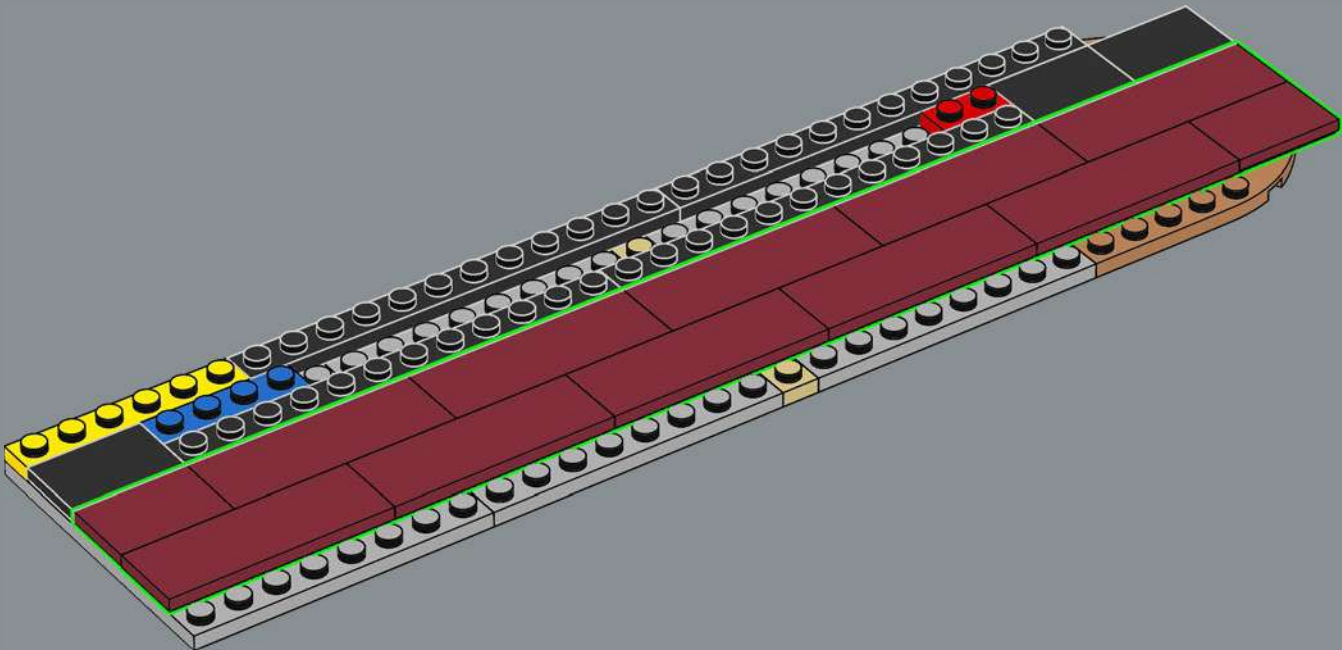

326

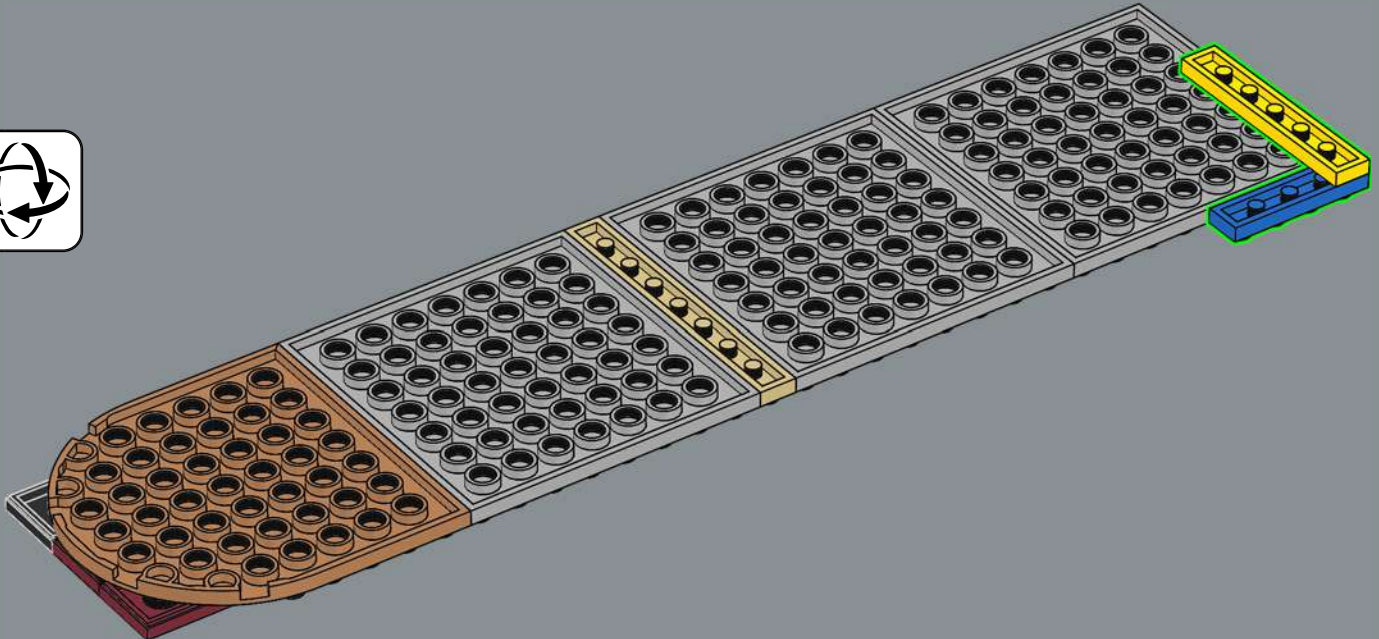

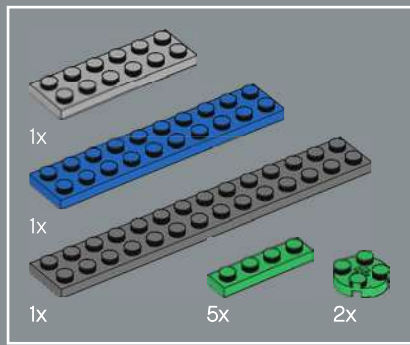

327

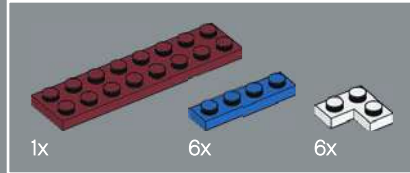
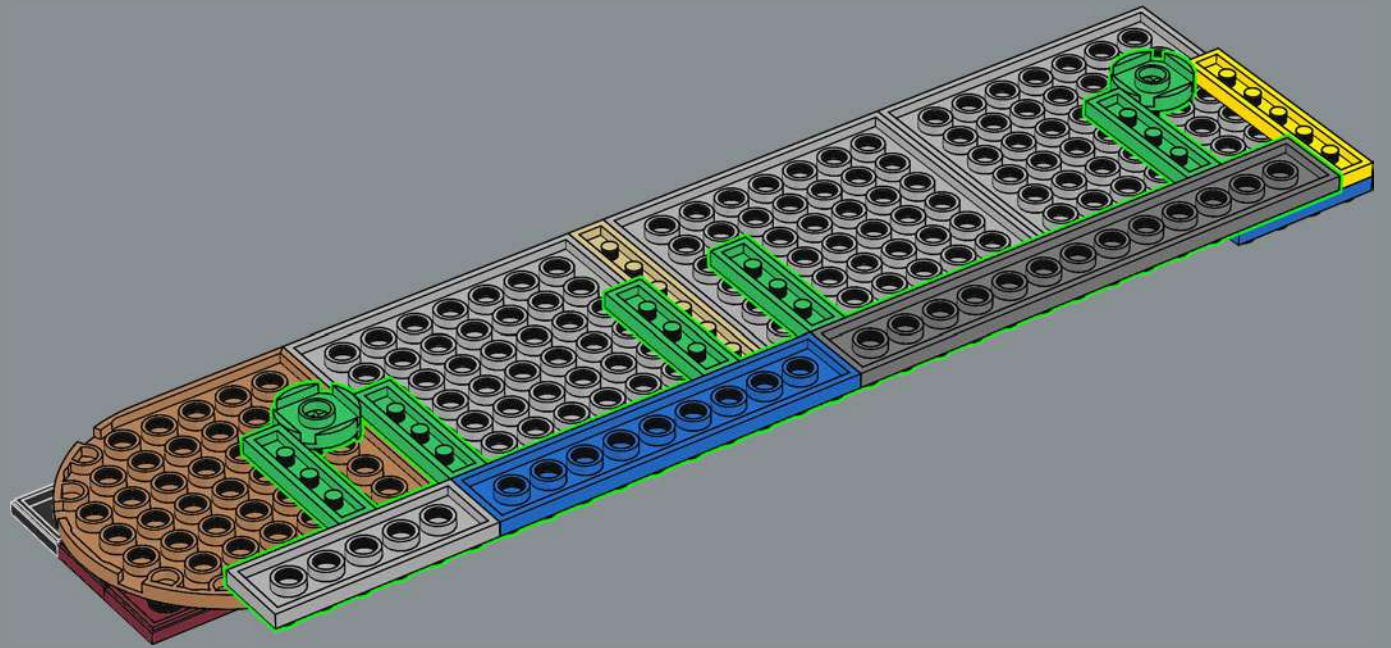

328

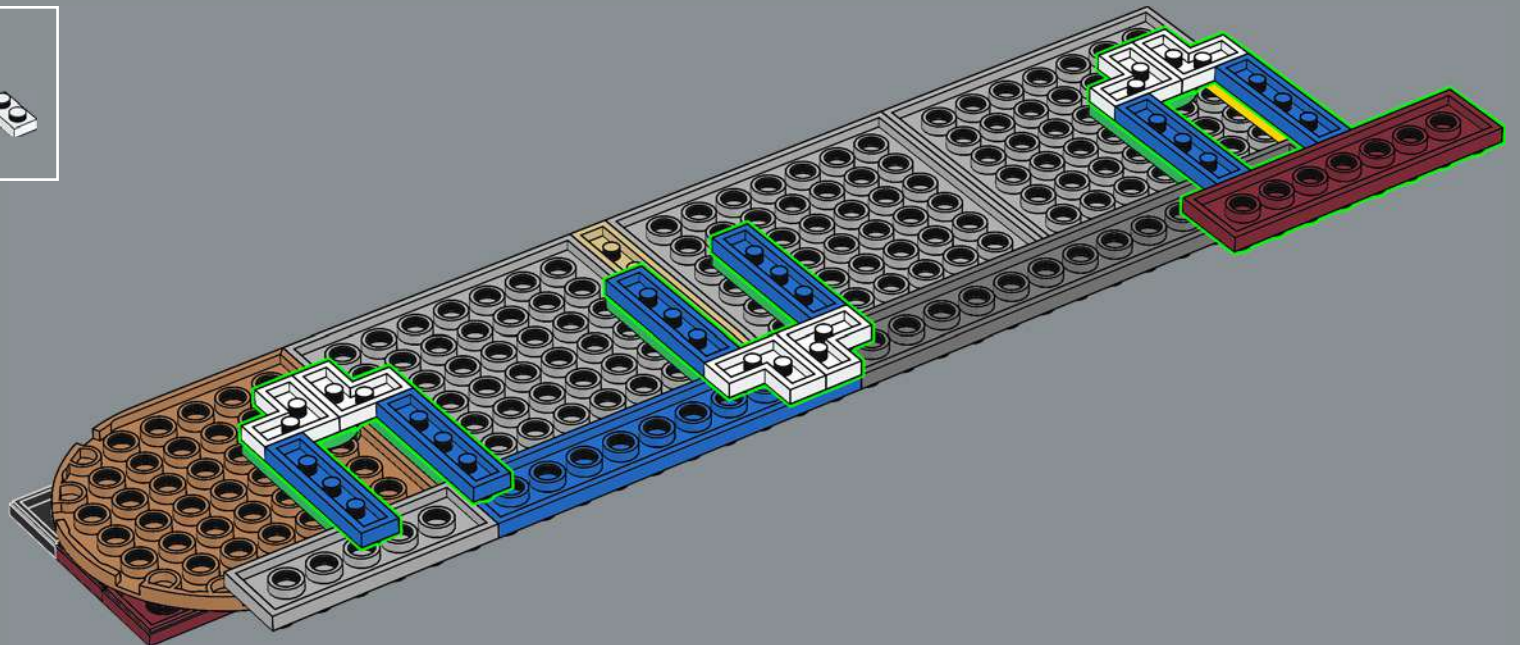

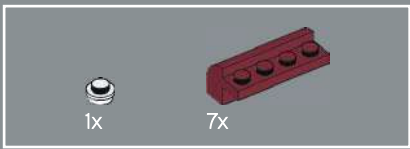

329

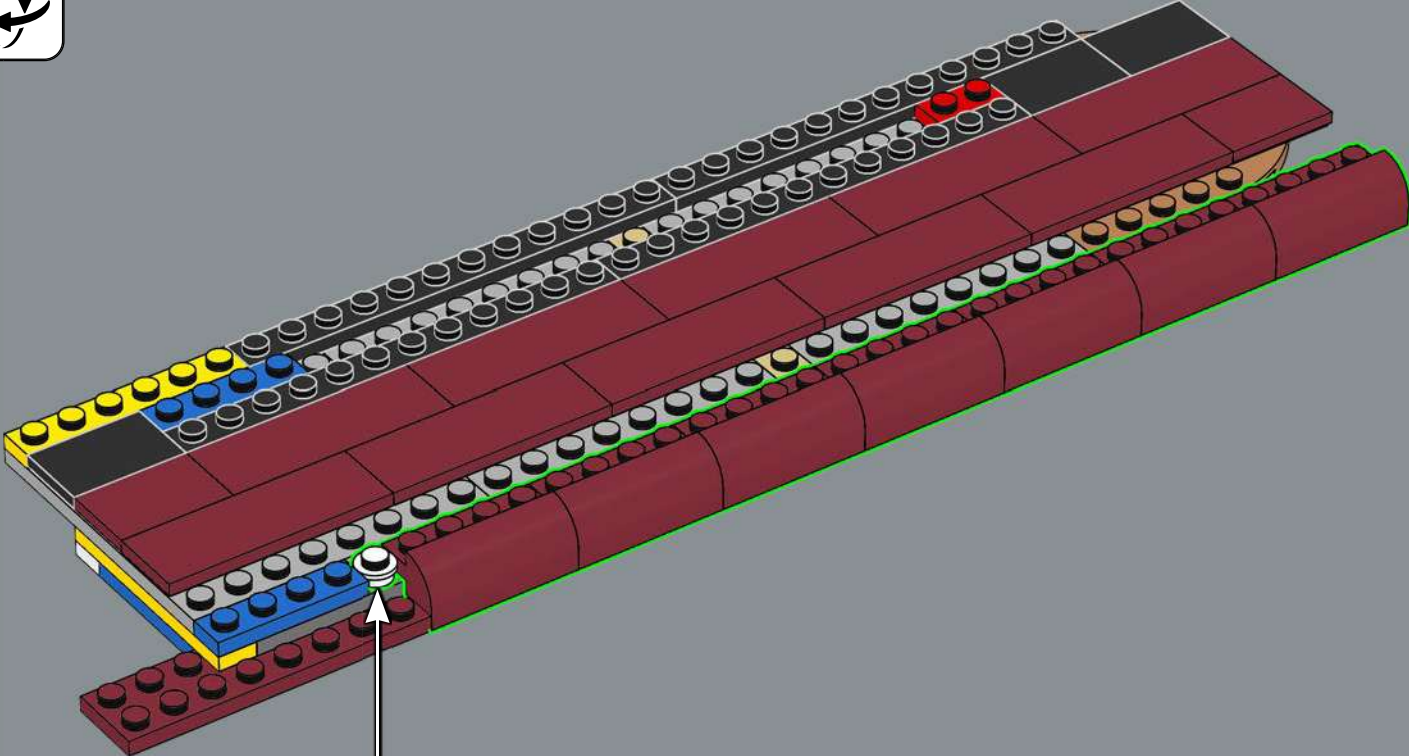

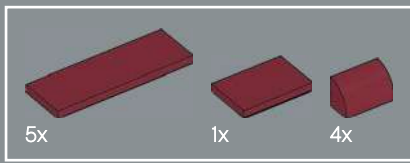

330

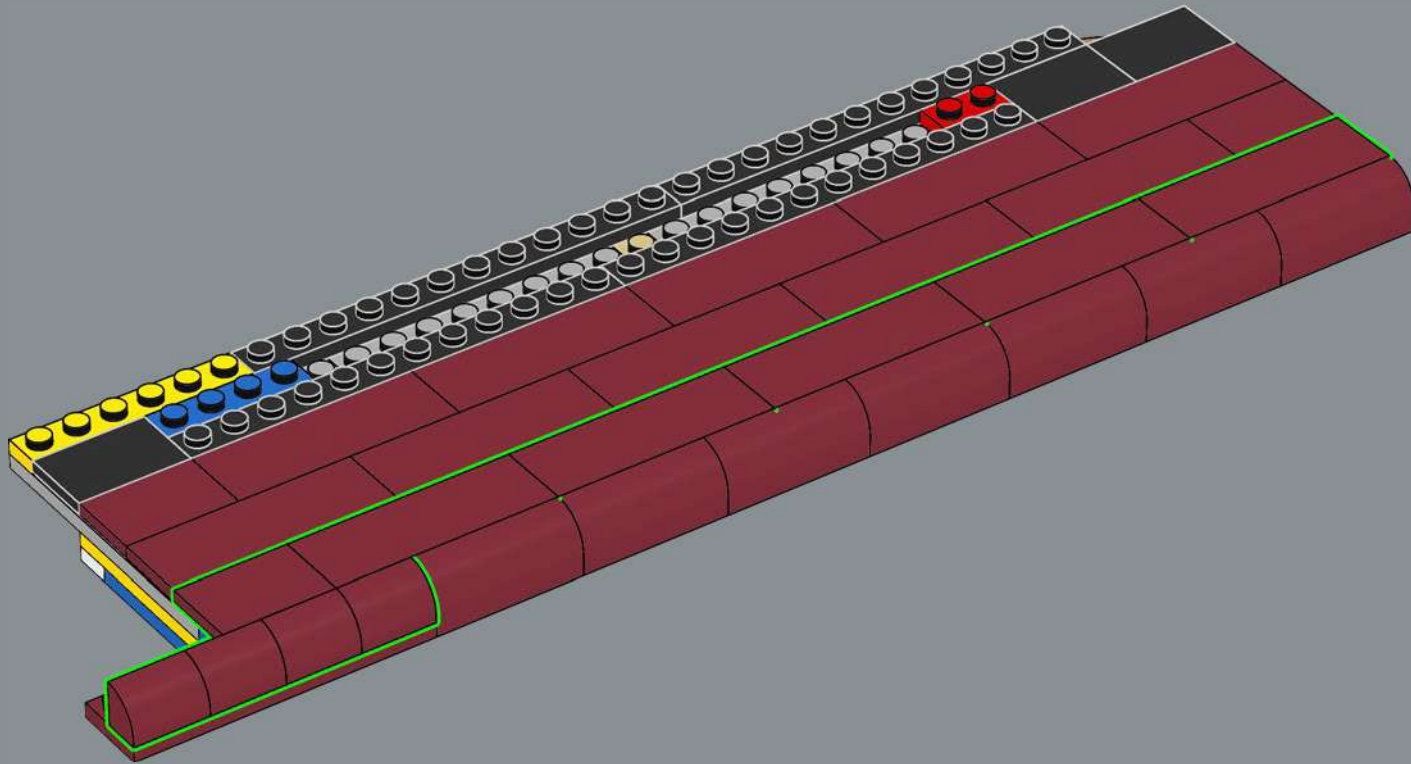



331

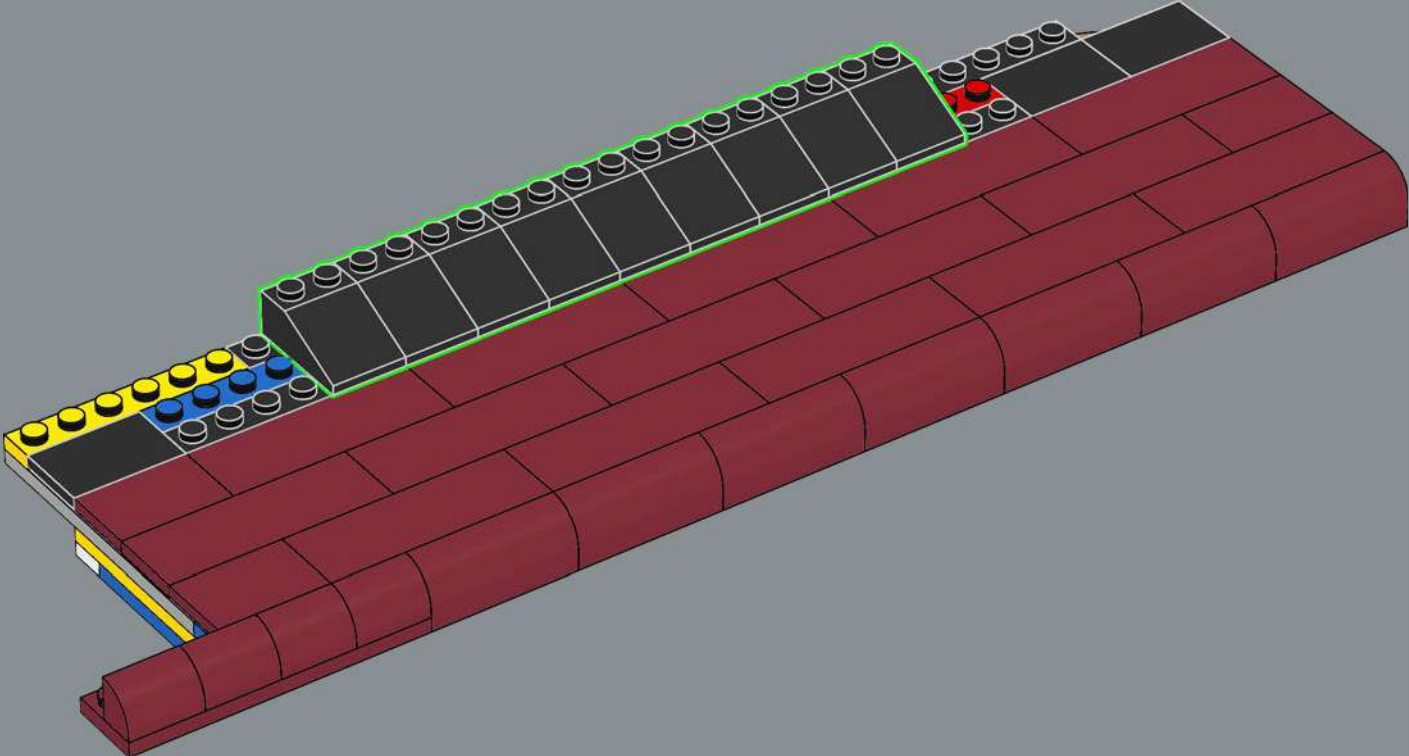

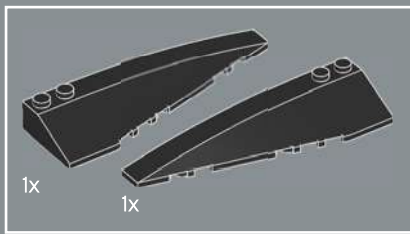

332

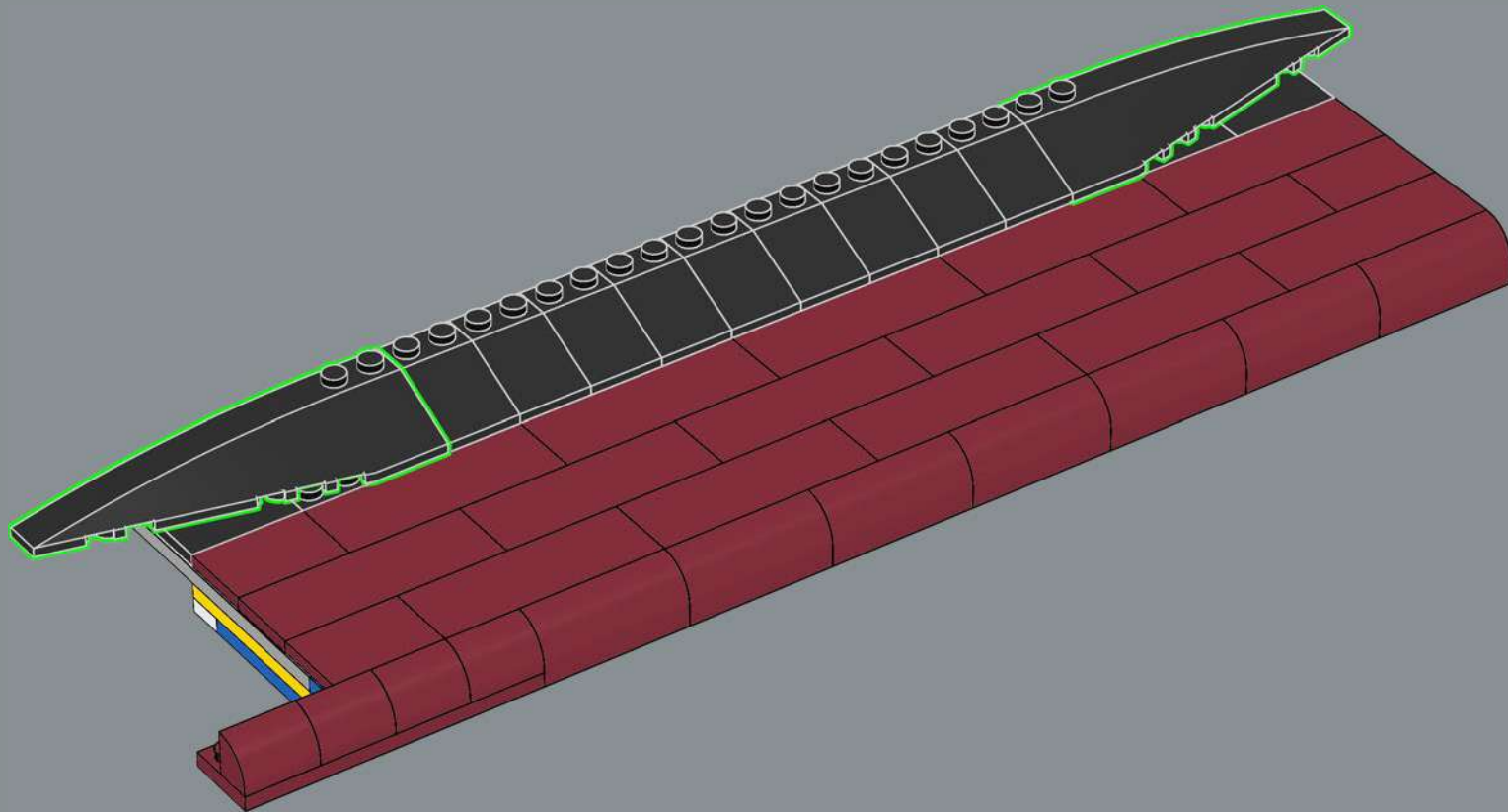

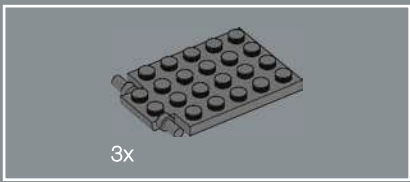

333

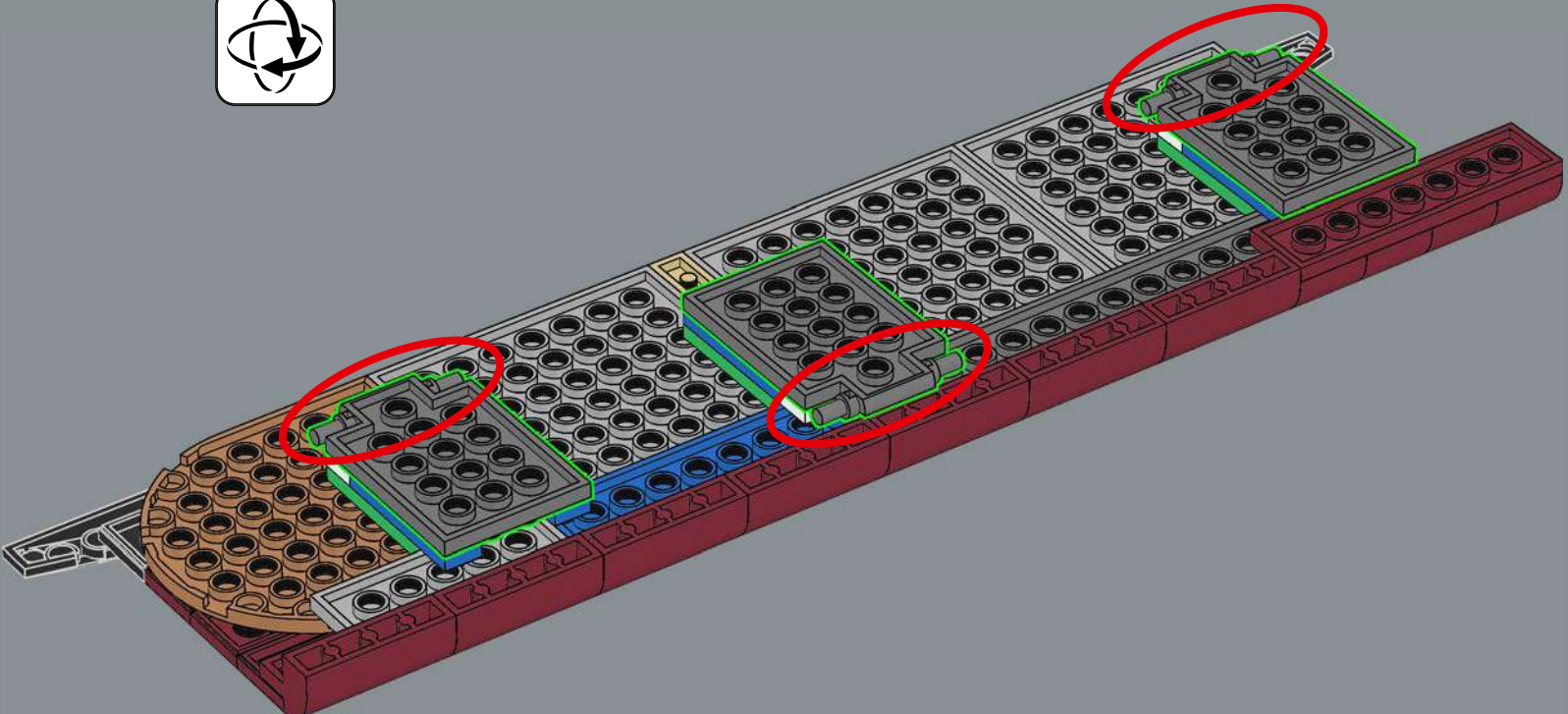



334

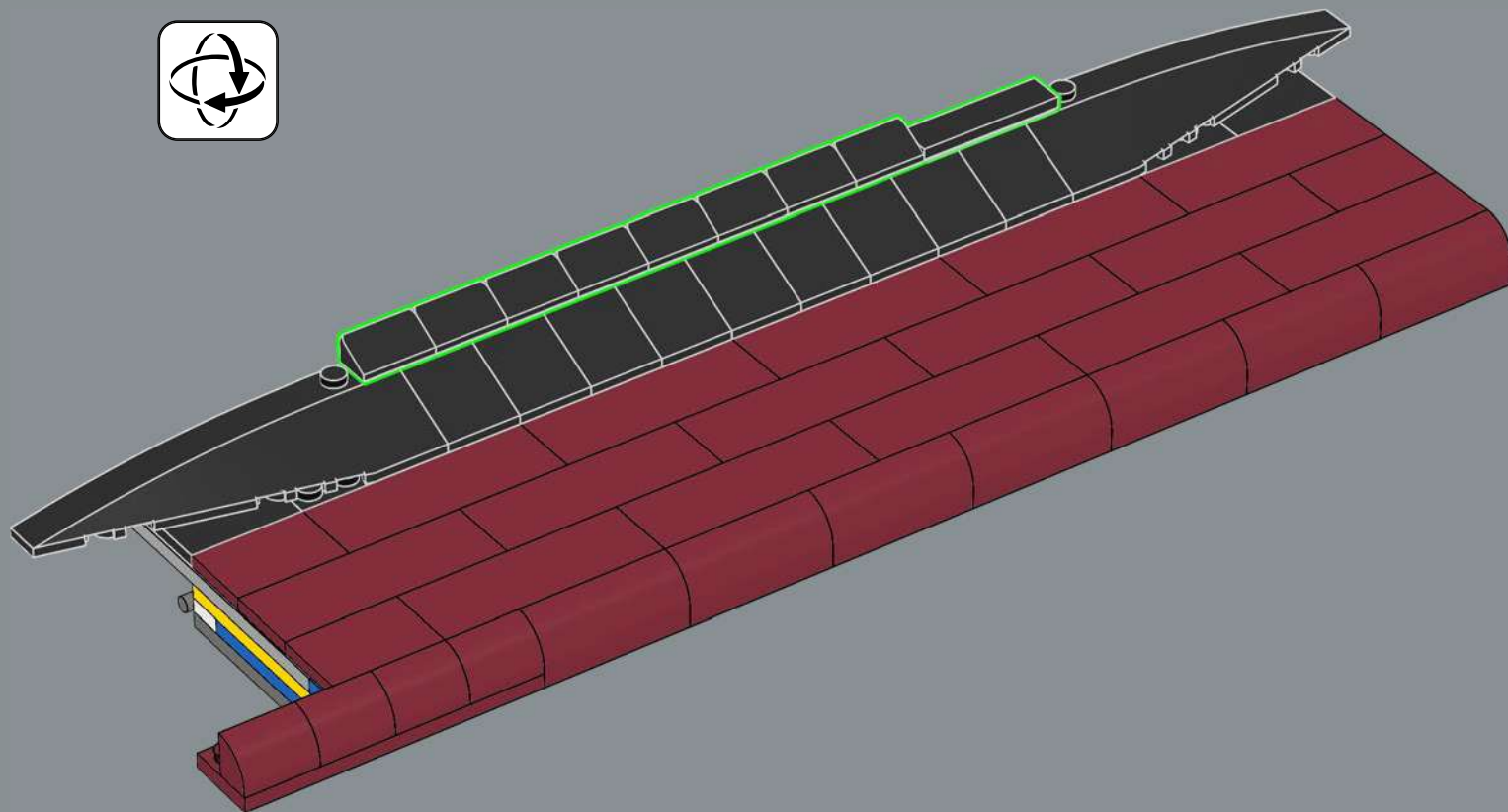

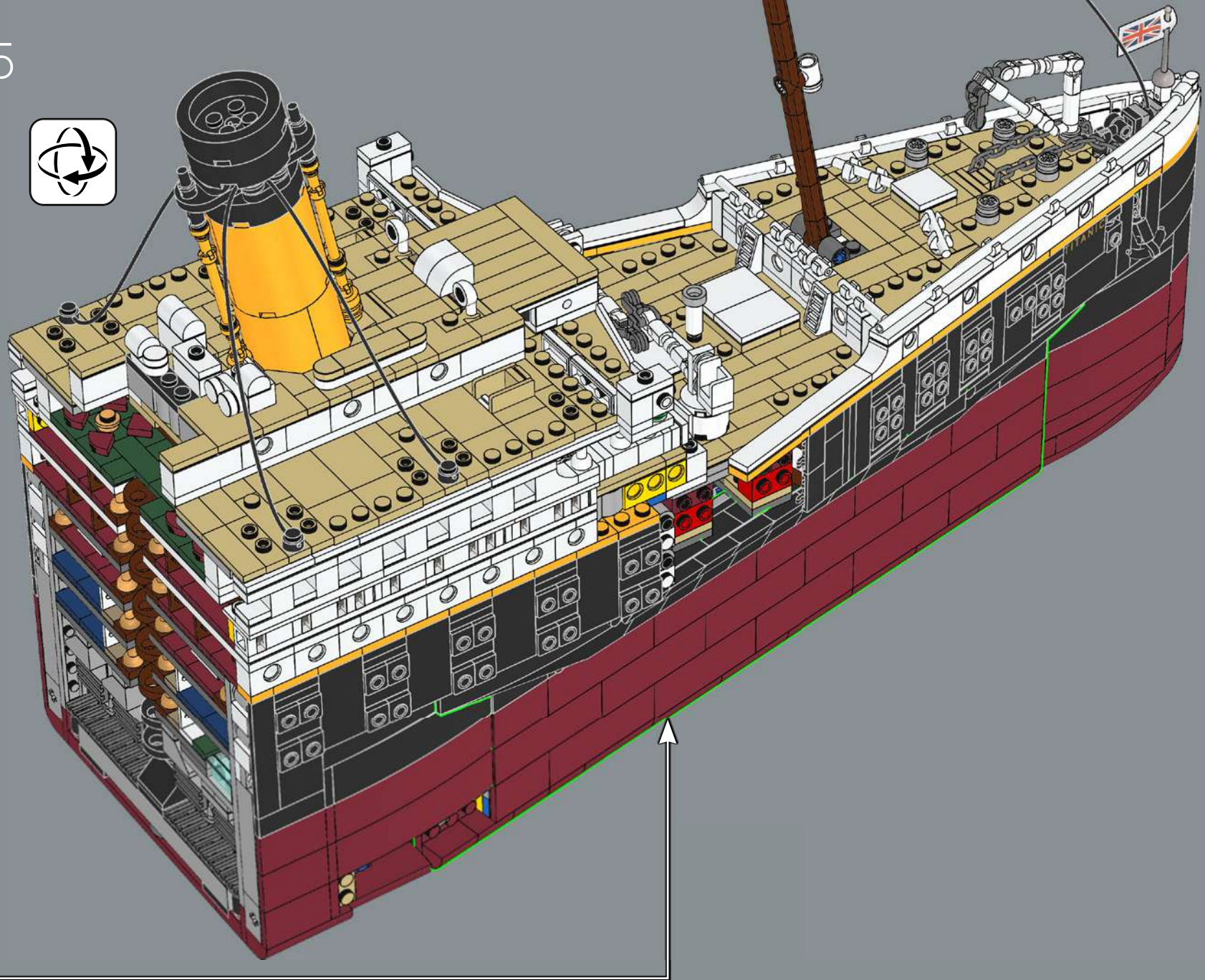

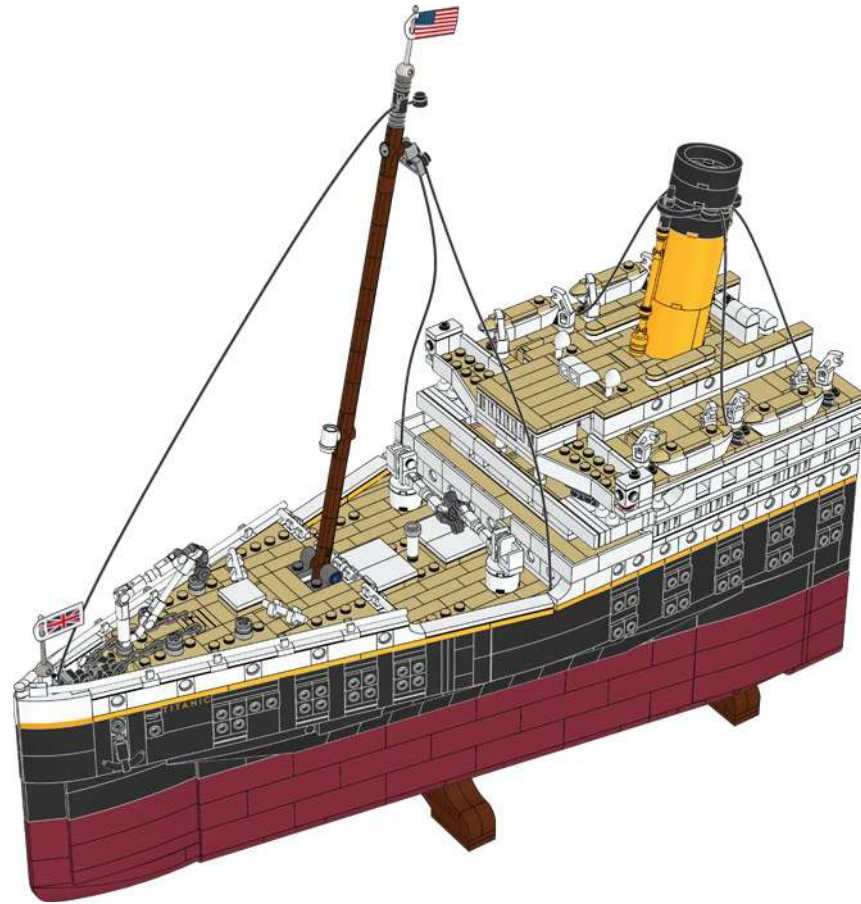
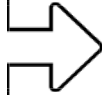

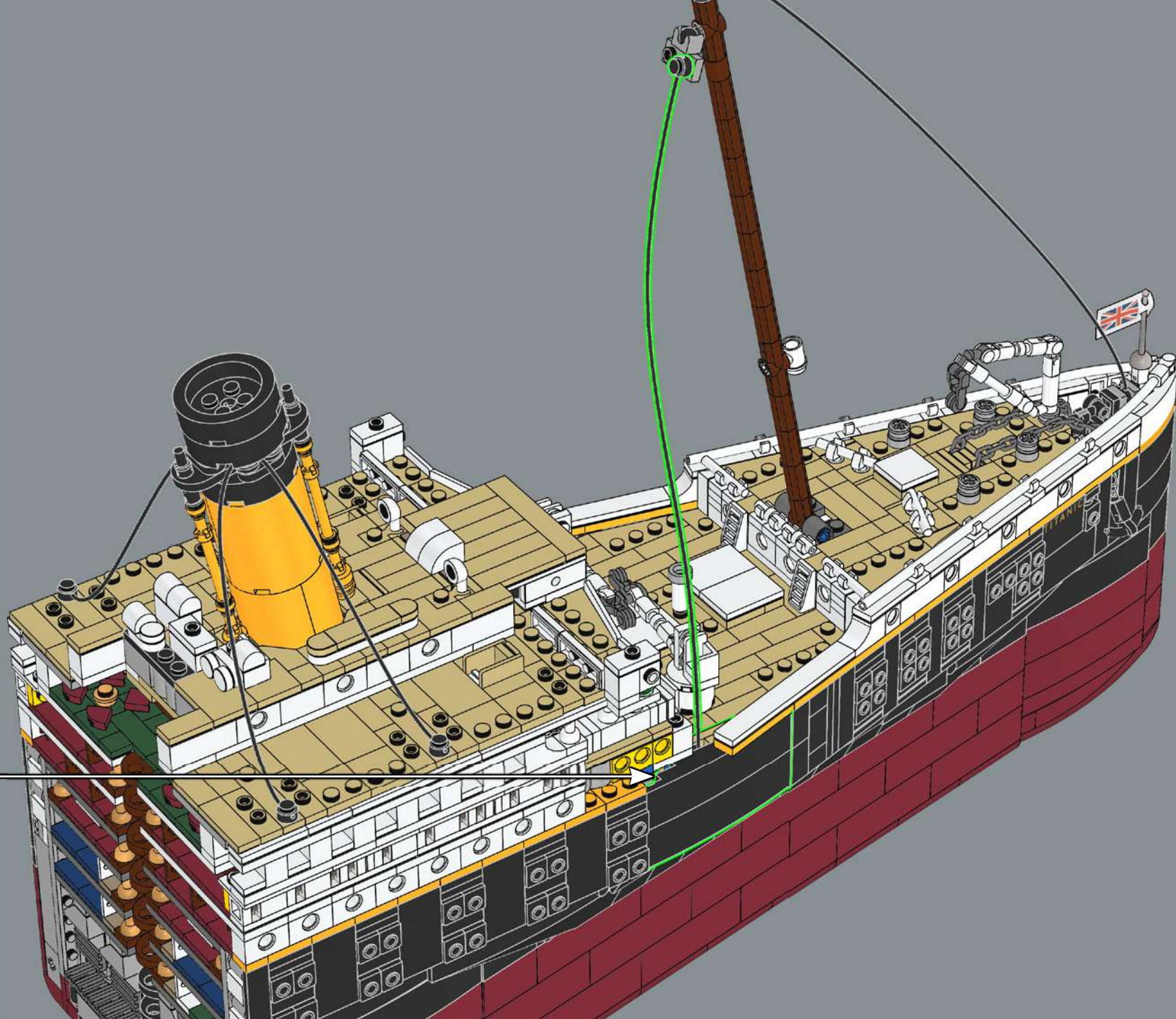

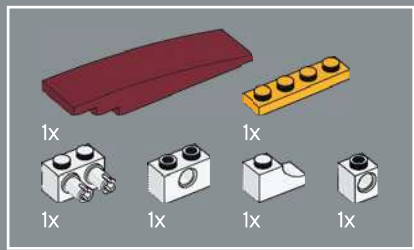

337

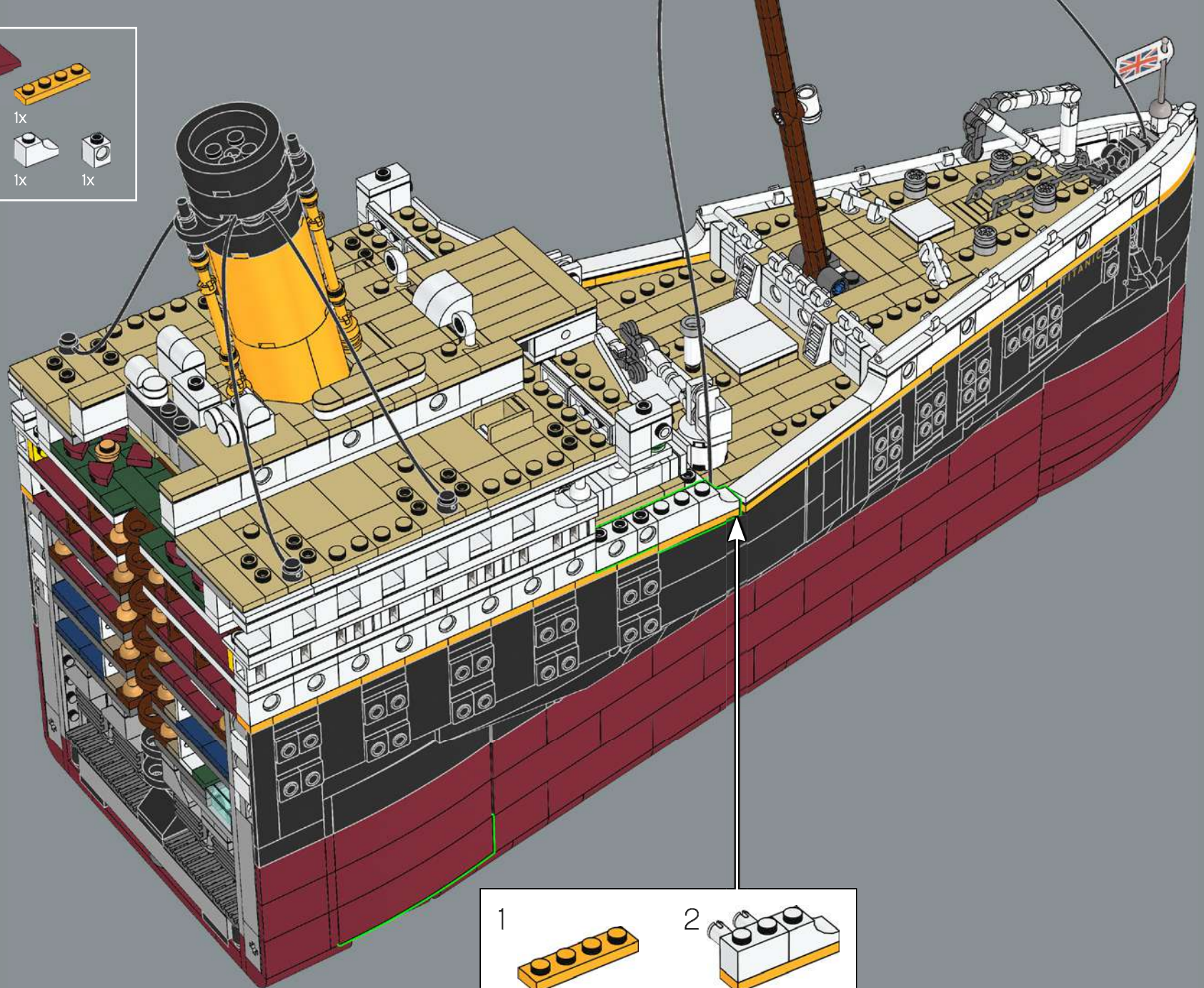

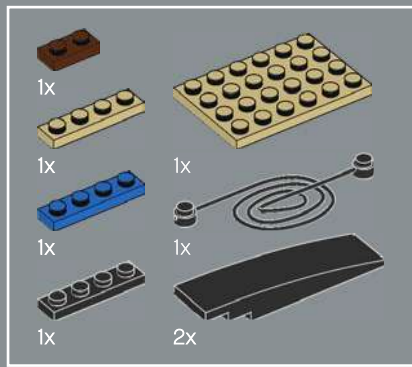

338

1

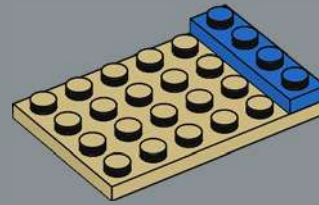

2

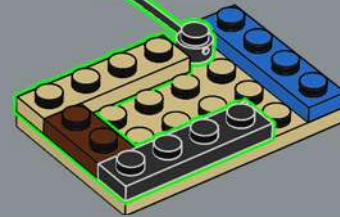

3

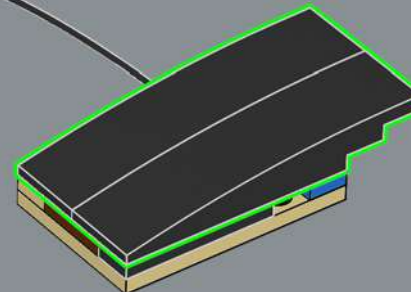

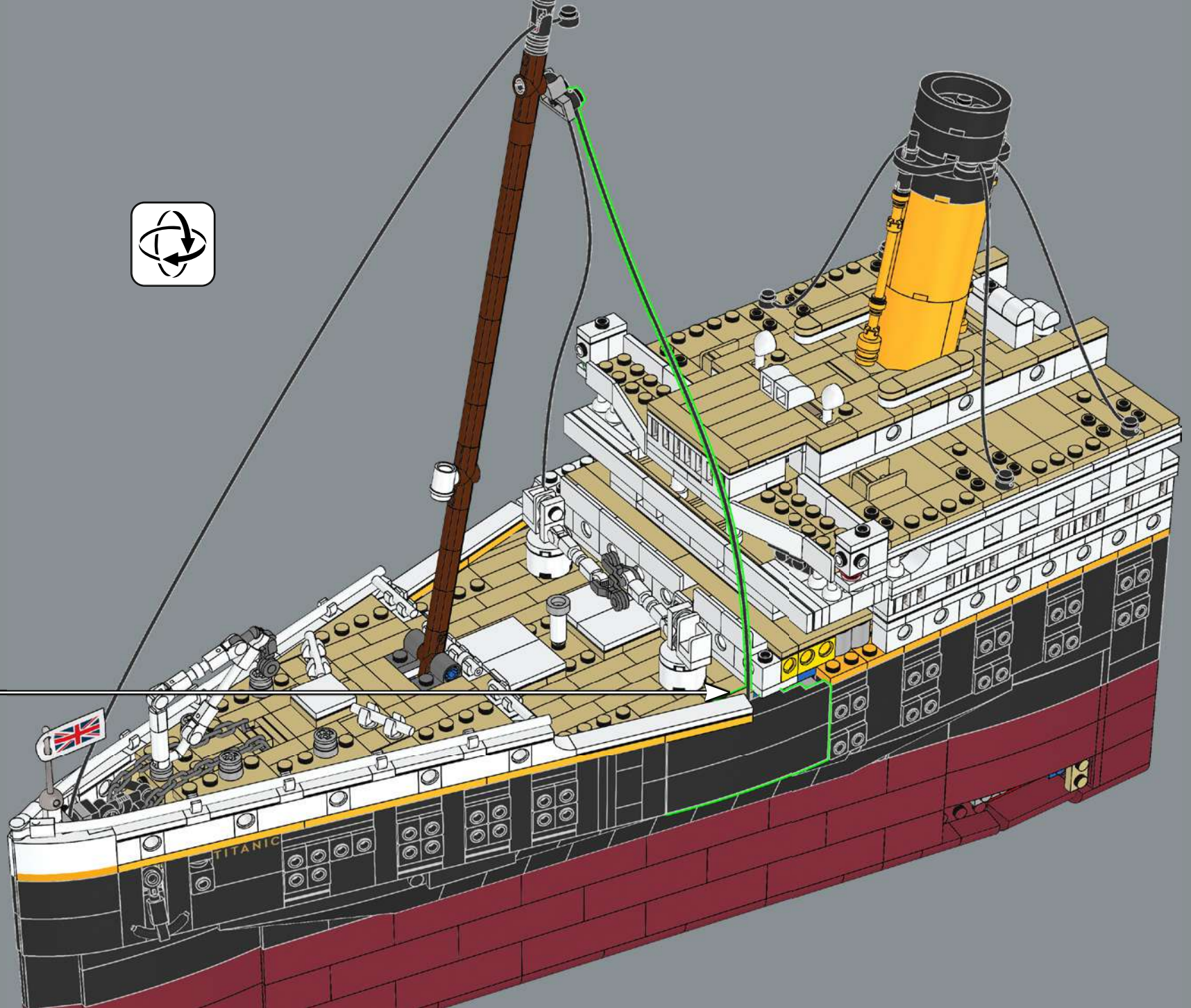

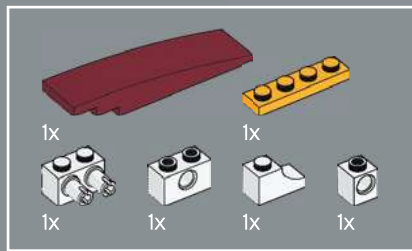

339

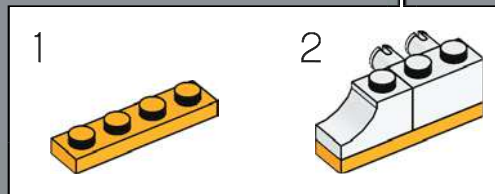
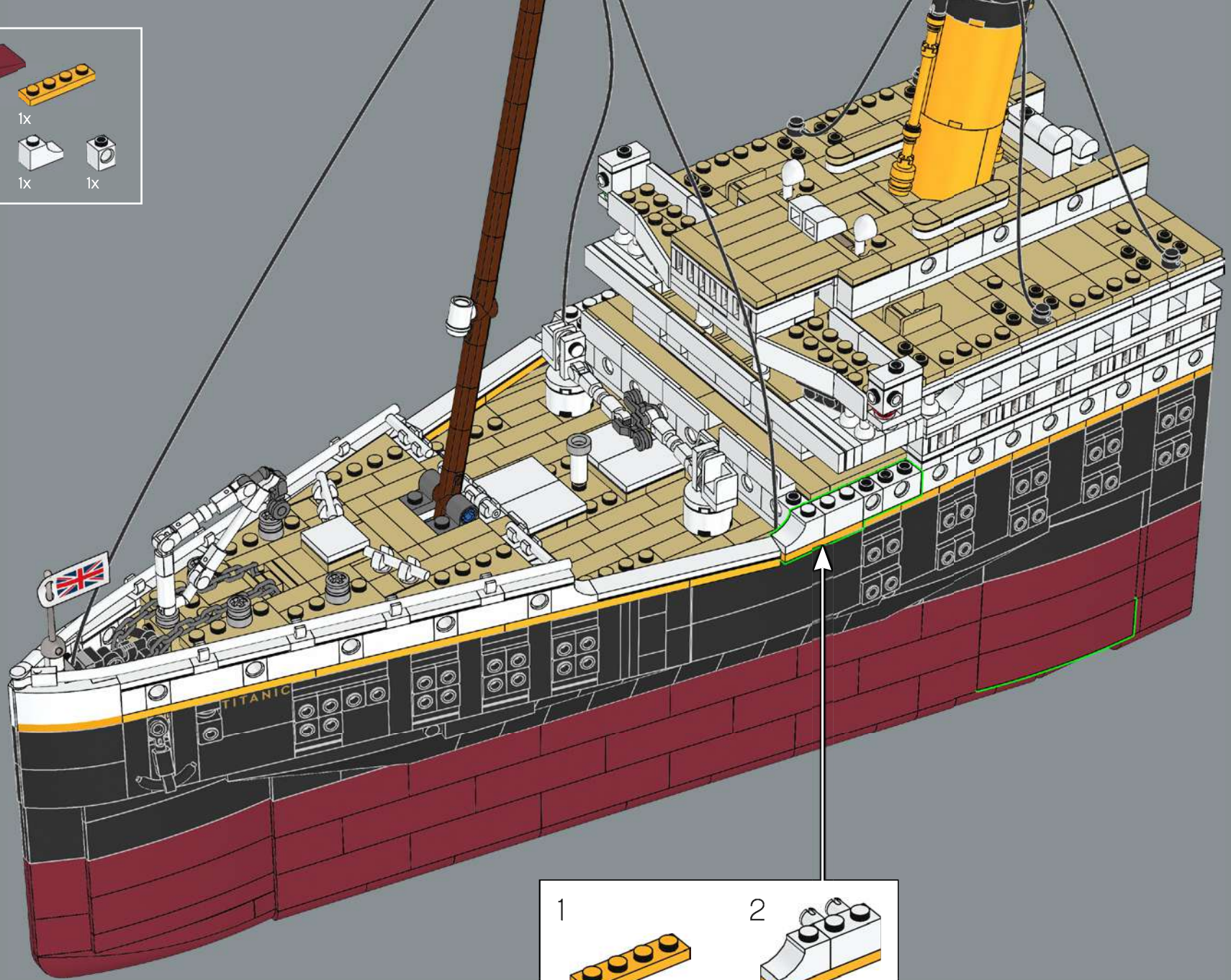

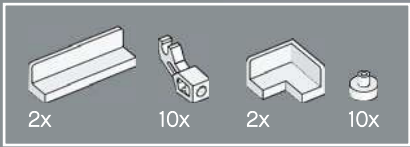

340

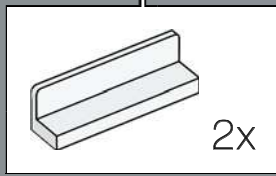
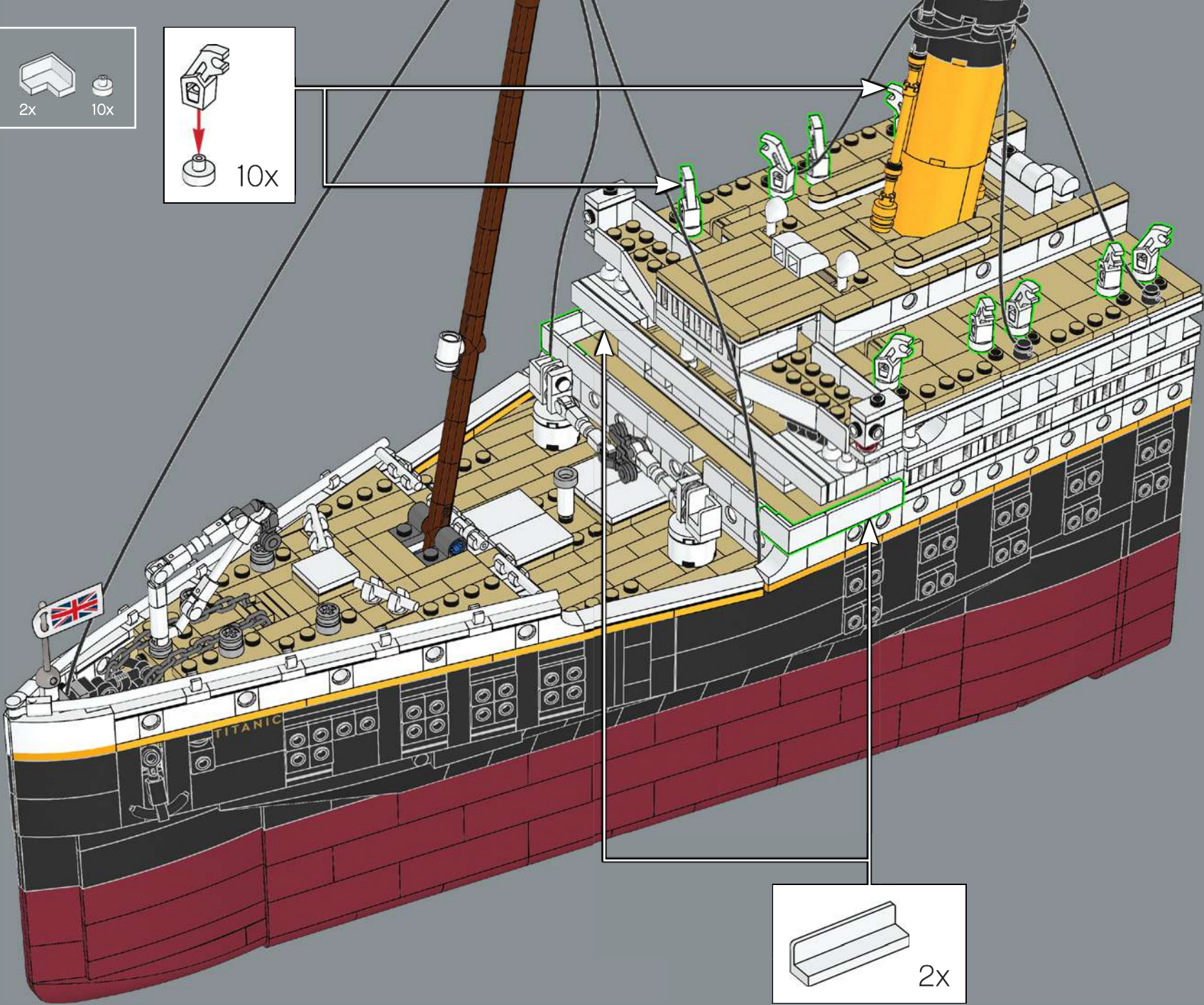
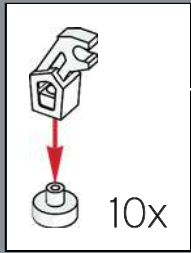



341

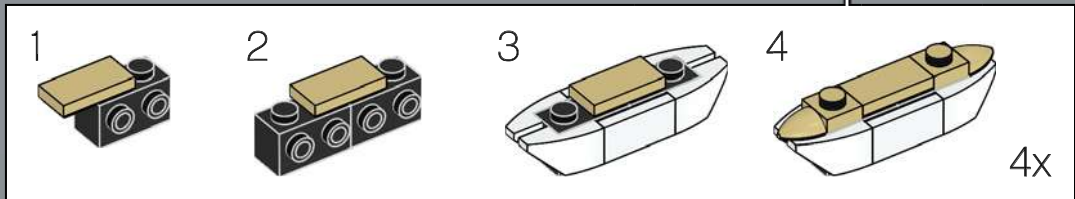
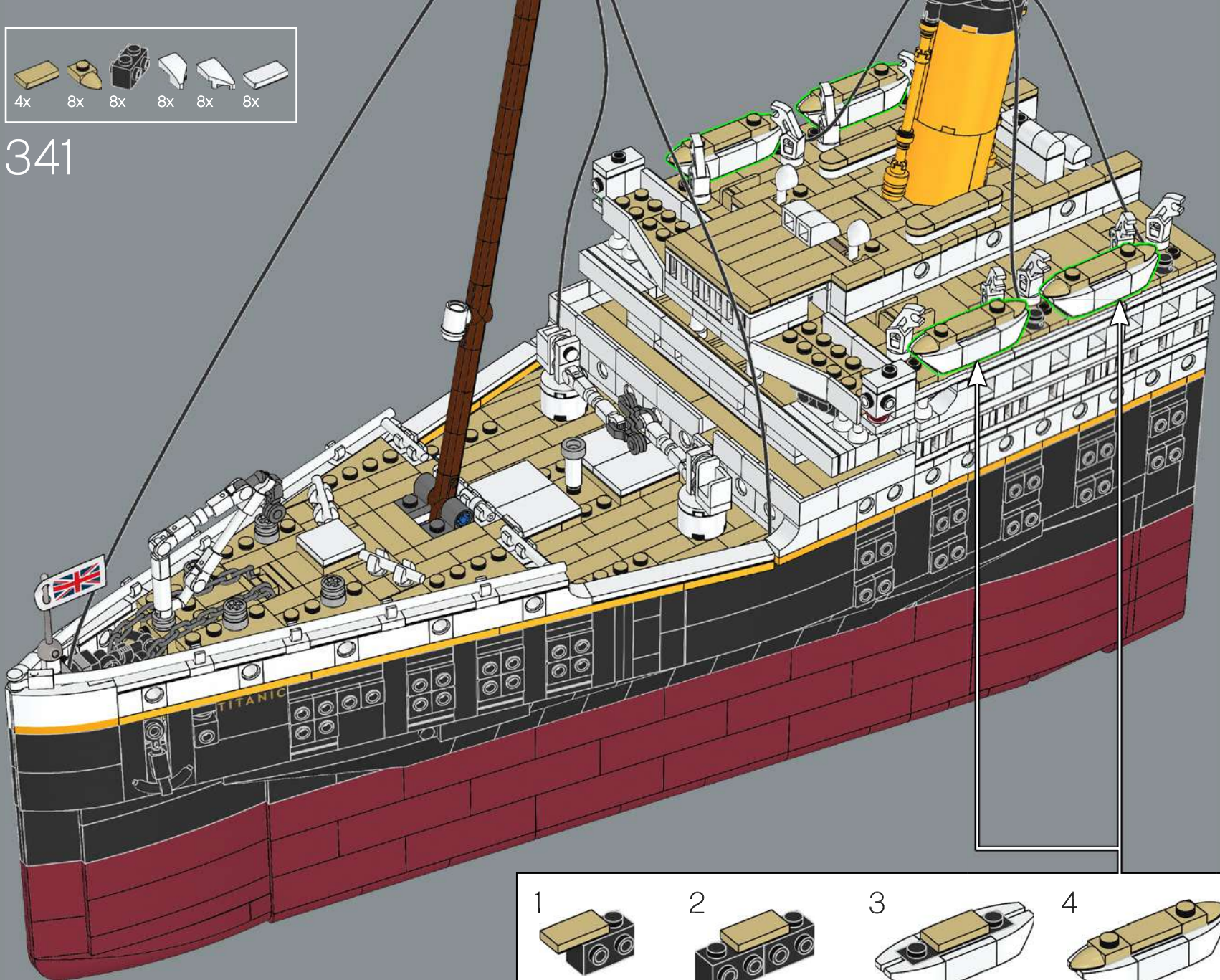

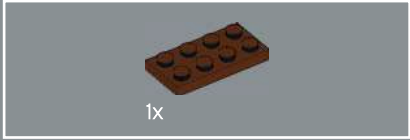
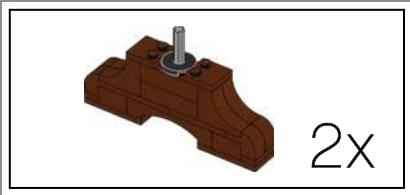

342

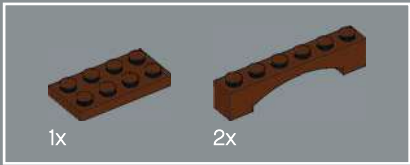
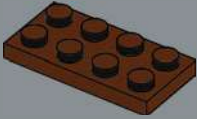

343

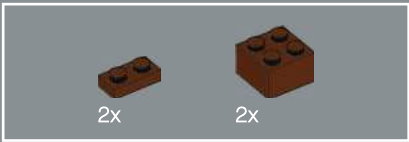
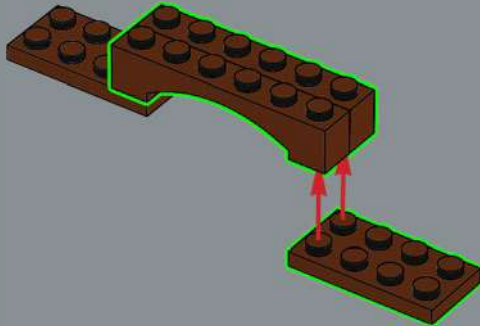

344

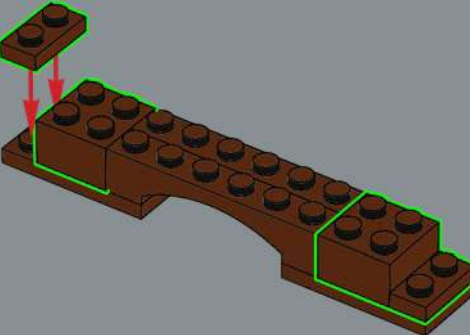

345

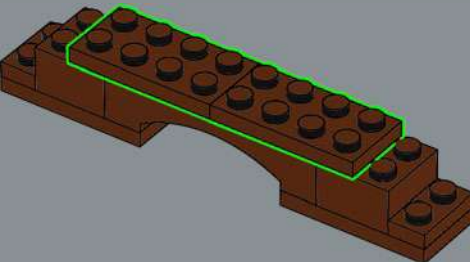

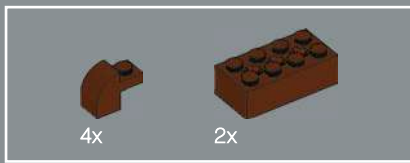

346

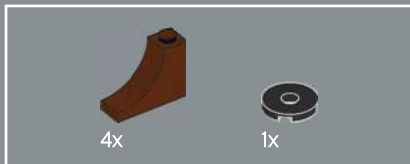
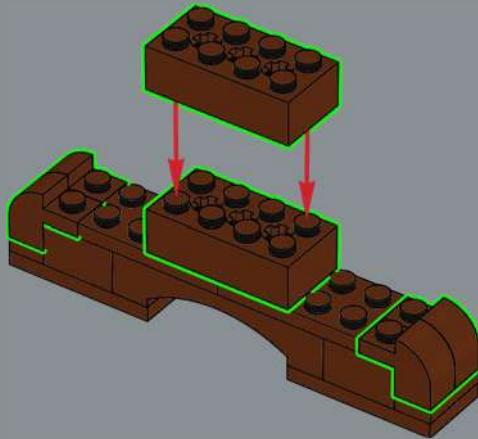

347

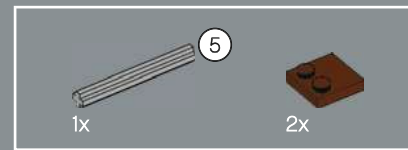
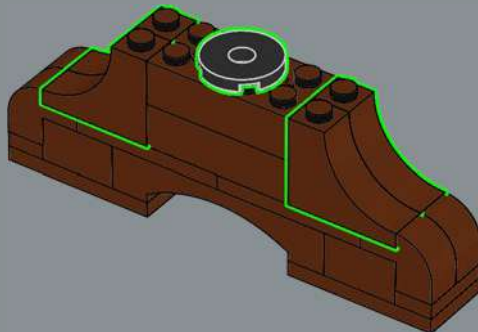

348

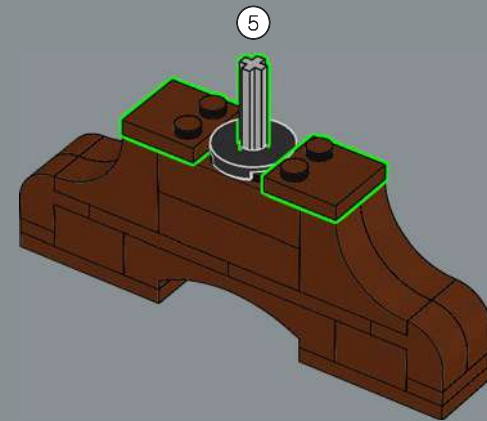

2x

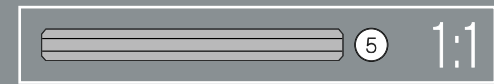

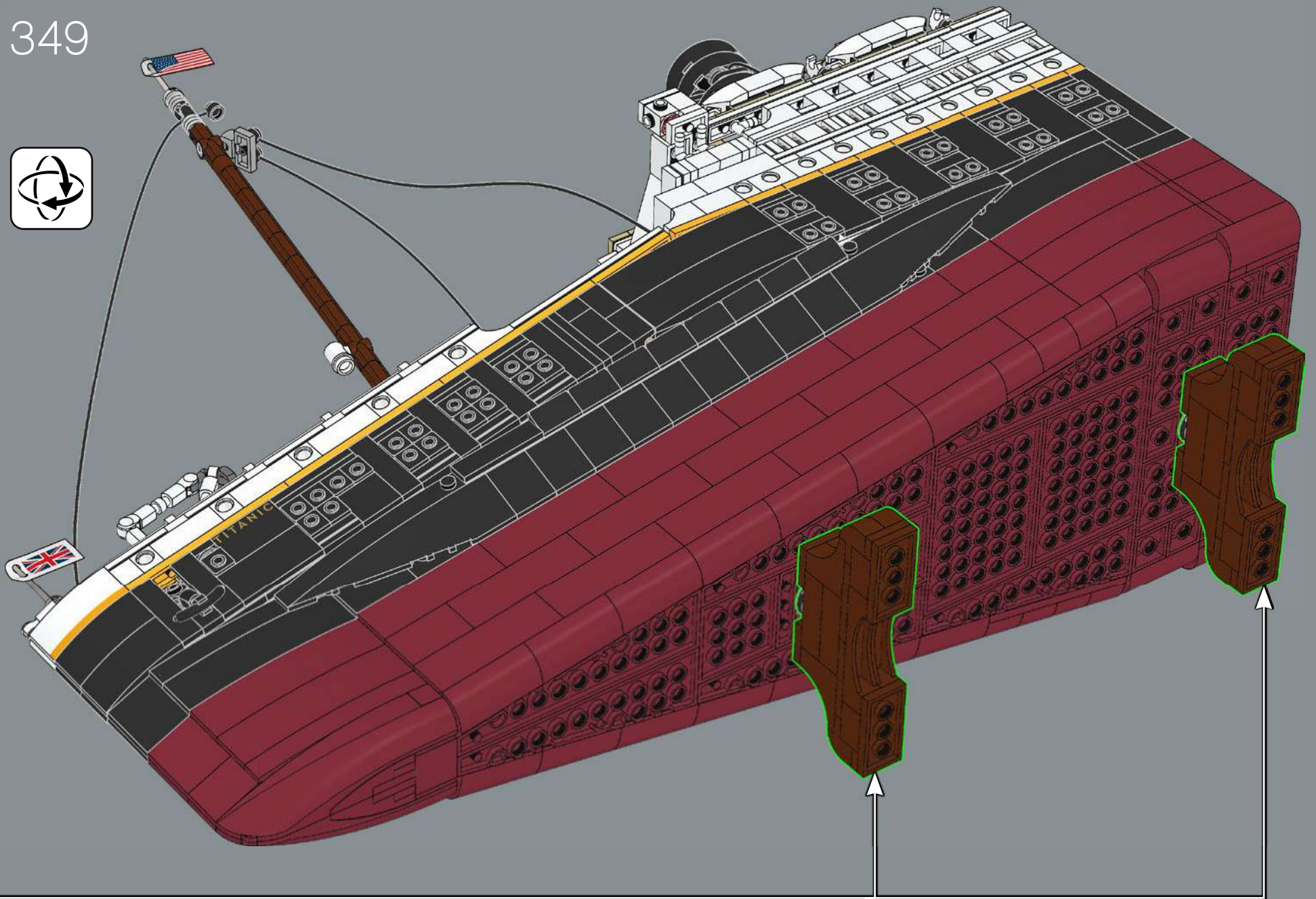

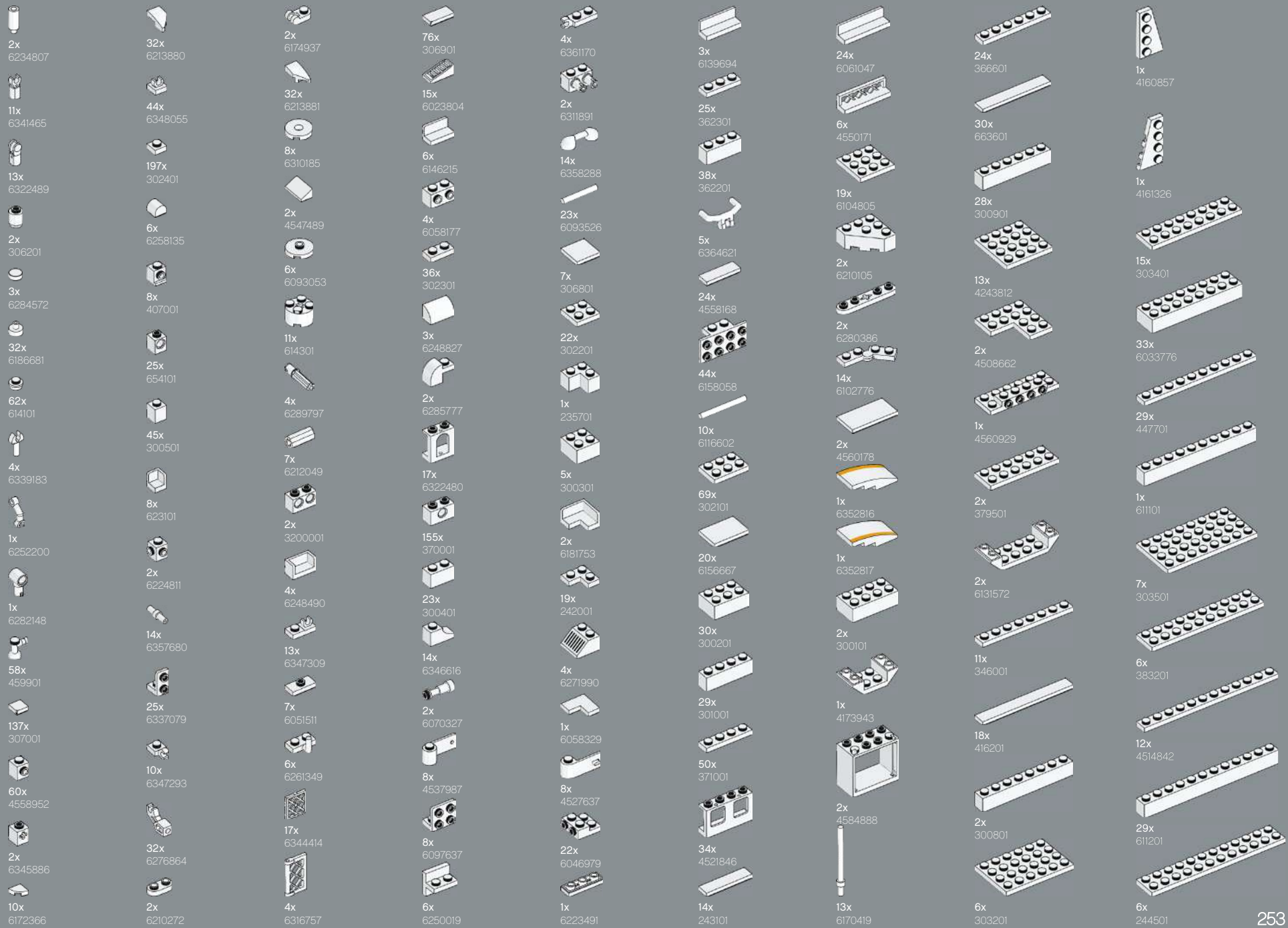



5x
6353196

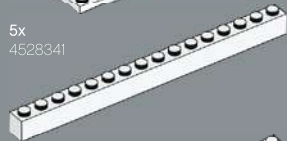

6x
4528341

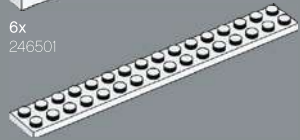

13x
246501



2x
6365707

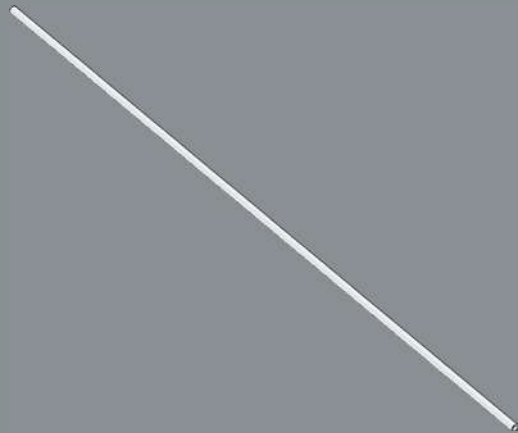

1x
6364683



1x
6370720



4x
6353196



44x
4118793



83x
6360078



2x
4113915



5x
4179771



54x
4125253



10x
4516055



20x
4159553



2x
4612603



2x
6357613



32x
4224793



4x
6355727



6x
6351413



14x
6352222



8x
6177890



8x
6177891



4x
4624086



4x
6232037



50x
4218749



41x
6092587



2x
6338180



4x
6148262



6x
4109995



6x
6146221



2x
6024495



13x
4205107



1x
6063943



2x
6294481



2x
6103001



153x
4114026



21x
4113917



20x
6034929



2x
4273526



2x
6214334



4x
6117975



4x
6249809



10x
6174925



5x
6253003



2x
6314477



2x
6358290



2x
6358289



1x
4565387



39x
4185177



44x
6221467



44x
4114084



47x
6173057



18x
4114077



16x
6265572



4x
6211975



96x
6131896



14x
4121921



2x
4624088



34x
6211966



2x
6318084



8x
4118790



9x
6175367



2x
4500453



5x
4666999



2x
4113233



12x
4550324



26x
6257600



2x
6195544



2x
6115031



2x
4208072



33x
4114309



53x
6122047



8x
6351905



2x
4112982



10x
4157277

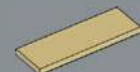

3x
6331158



4x
4113993

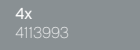

5x
4181134



49x
4114324



11x
4544139

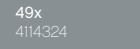

12x
4159774



2x
4114001



2x
4125217



2x
4166138



3x
4509897



4x
6070501

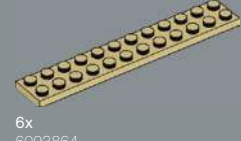

6x
6093864



6x
6284574



2x
306221



8x
654121



10x
6345429



1x
6210269



46x
4142865



2x
6168634



4x
6019155



1x
6265697



22x
302321



2x
245821



2x
6313831

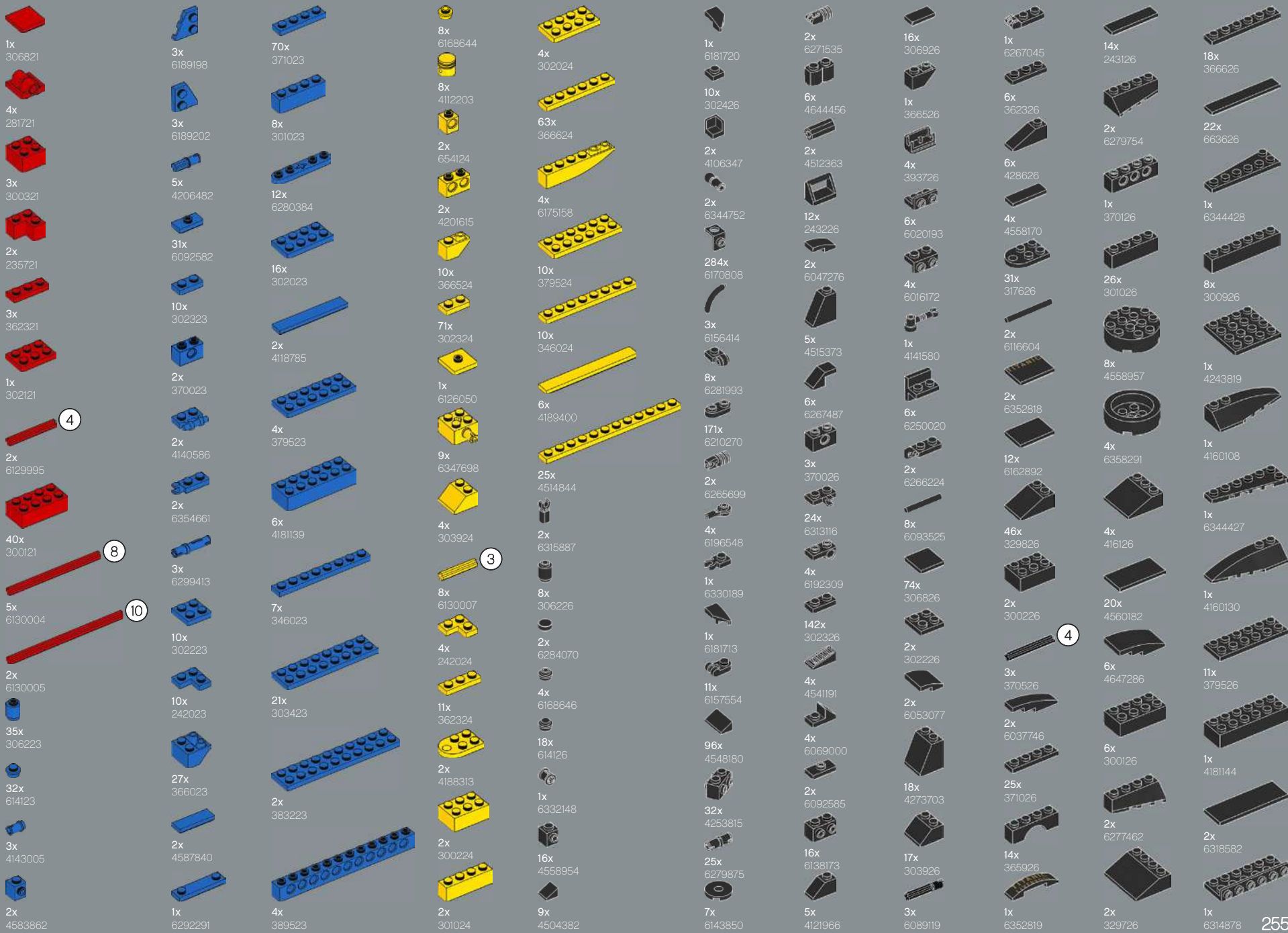

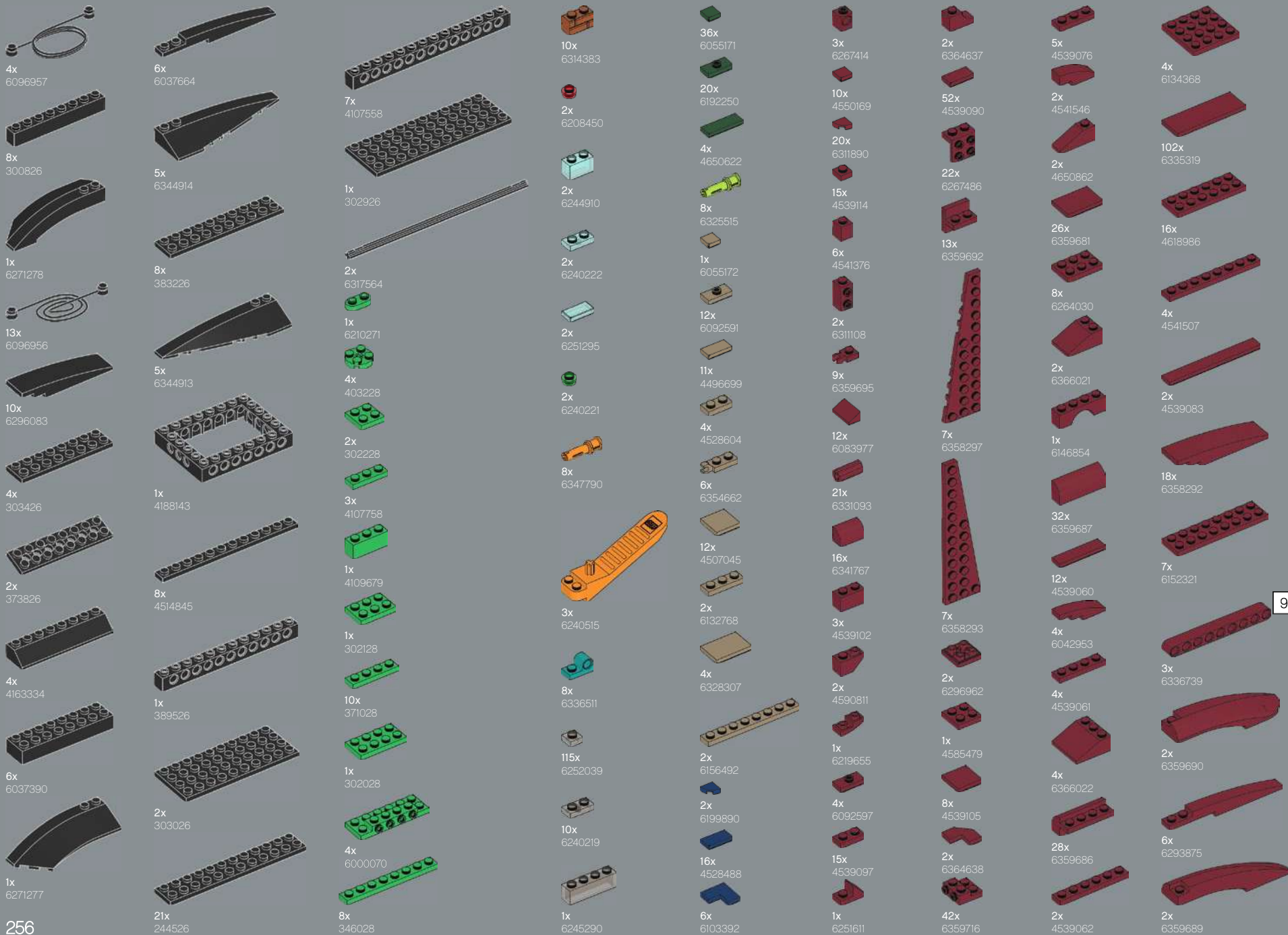

4x
6096957

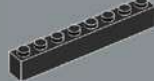

8x
300826



1x
6271278



13x
6096956

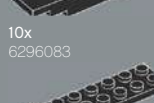

10x
6296083



4x
303426



2x
373826

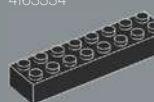

4x
4163334

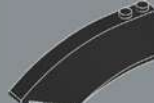

6x
6037390

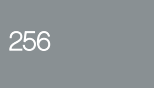

1x
6271277



6x
6037664



5x
6344914



8x
383226



5x
6344913



1x
4188143

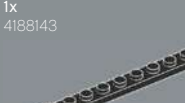

8x
4514845



1x
389526



2x
303026



21x
244526

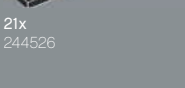

7x
4107558



1x
302926



2x
6317564

1x
6210271

4x
403228

2x
302228

3x
4107758

1x
4109679

1x
302128

10x
371028

1x
302028

4x
6000070

8x
346028

115x
6252039

10x
6240219

10x
6240219

1x
6245290

10x
6314383

2x
6208450

2x
6244910

2x
6240222

2x
6251295

2x
6240221

8x
6347790

3x
6240515

8x
6336511

115x
6252039

10x
6240219

10x
6240219

1x
6245290

36x
6055171

20x
6192250

4x
4650622

8x
6325515

1x
6055172

12x
6092591

11x
4496699

4x
4528604

6x
6354662

12x
4507045

2x
6132768

4x
6328307

2x
6156492

2x
6199890

16x
4528488

6x
6103392

3x
6267414

10x
4550169

20x
6311890

15x
4539114

6x
4541376

2x
6311108

9x
6359695

12x
6083977

21x
6331093

16x
6341767

3x
4539102

2x
4590811

1x
6219655

4x
6092597

15x
4539097

1x
6251611

2x
6364637

52x
4539090

22x
6267486

13x
6359692

7x
6358297

7x
6358293

2x
6296962

1x
4585479

8x
4539105

2x
6366022

8x
4539105

2x
6364638

42x
6359716

5x
4539076

2x
4541546

2x
4650862

26x
6359681

8x
6264030

2x
6366021

1x
6146854

32x
6359687

12x
4539060

4x
6042953

4x
4539061

4x
6366022

4x
6366022

28x
6359686

2x
4539062

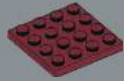

4x
6134368

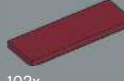

102x
6335319



16x
4618986

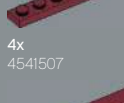

4x
4541507

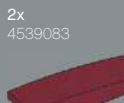

2x
4539083



18x
6358292

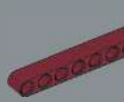

7x
6152321



3x
6336739

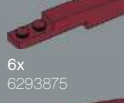

2x
6359690

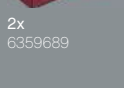

6x
6293875

2x
6359689

9

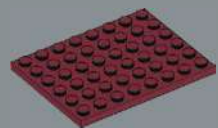

11x
6028115



8x
6186106



8x
6245265



16x
6134252



8x
6223719



16x
6331261



6x
6073040



6x
6028736



91x
6097503



16x
6358295



16x
6020073



4x
6359223



12x
6020074



9x
6192205

6x
4211183



19x
4216581



1x
6170813



2x
6149677



12x
4221744



26x
4211288



46x
4225469



4x
6325717



29x
4531751



2x
4211222



1x
4211252



14x
6365885



105x
4211150



24x
6335567



1x
4211151



10x
6365884



24x
4645103



39x
6236915



20x
6196221



30x
4211210



10x
6365883



5x
6333110



6x
4211220



20x
4211152



24x
6133833



9x
6172636



30x
4211186



14x
6365882



1x
4221590



18x
4211193



12x
4655611



1x
4216615



6x
6313736



2x
4211211

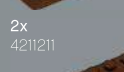

2x
4222627

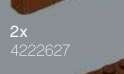

1x
6338230



88x
4211412



23x
6258831

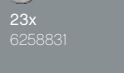

7x
6372076



1x
4211483

3x
4558953



12x
4211399



2x
6225242



2x
6345639



8x
6335378



8x
4211375



8x
6227897



4x
4568637



2x
6352979



2x
6352983



1x
6352986



1x
6352997



1x
6353001



155x
4550325



2x
6372076



16x
6093859



4x
6327412



9x
6338165



2x
4211564



20x
4211398



8x
4211414



8x
4211440



10x
6206249



1x
6326078



8x
6146300



8x
6146300



8x
6146300



8x
4211363



4x
4211494



2x
4211614



4x
6117967



6x
4654580



8x
4211609



4x
6337268



4x
6078211



4x
6198932



4x
4667578



4x
4211461



4x
4211632



4x
6321743



1x
4208988



1x
4209006



8x
4211397



46x
6212077



6x
6007894



6x
4234535



4x
4211815



4x
6078212



8x
6195471



1x
6346487



4x
6326483



1x
6304930



15x
6211969



8x
4211419



11x
4211773



30x
4211396



1x
4211386



9x
4211394



1x
4211441



2x
4211445



26x
4211636



8x
6230229



2x
4211361



2x
4211395



8x
4211385



6x
4211639



4x
6256117



8x
6105964



6x
4211393



16x
4211438



2x
4612621



2x
4211837



2x
4527174



4x
6015349



35x
4211452



13x
4211795



4x
6225219



4x
4211425





2x
4211442

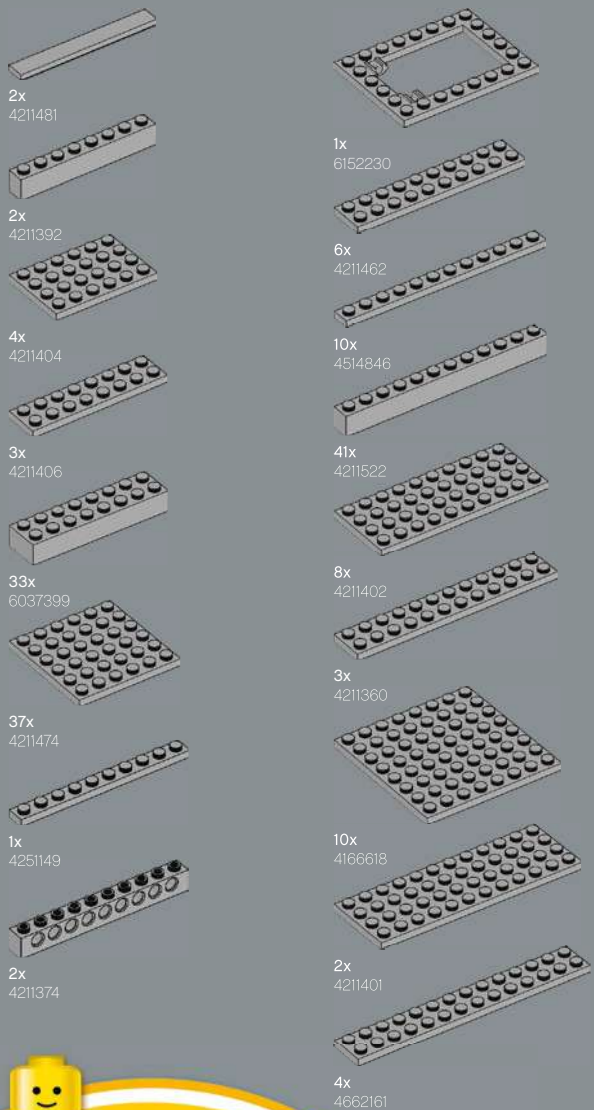

3

5





Customer Service
Kundenservice
Service Consommateurs
Servicio Al Consumidor

LEGO.com/service or dial

00800 5346 5555 : 

1-800-422-5346 : 





FEEDBACK AND WIN



FEEDBACK AND WIN

Your feedback will help shape the future development of this product series.

Please visit:

FEEDBACK UND GEWINNEN

Dein Feedback trägt zur Weiterentwicklung dieser Produktreihe bei.

Geh auf:

COMMENTEZ ET GAGNEZ

Vos commentaires nous aideront à concevoir les futurs produits de cette gamme.

Rendez-vous sur :

COMENTA Y GANA

Tu opinión nos ayudará a dar forma al desarrollo de esta serie de productos en el futuro.

Visita:

反馈有奖

您的反馈将有助于我们在今后改进本系列产品。

请访问：

[LEGO.com/productfeedback](https://www.lego.com/productfeedback)

By completing, you will automatically enter a drawing to win a LEGO® set.

Terms & Conditions apply.

Durch Ausfüllen nimmst du automatisch an der Verlosung eines LEGO® Preises teil.

Es gelten die Teilnahmebedingungen.

En envoyant vos commentaires, vous serez automatiquement inscrit(e) à un tirage au sort qui vous permettra de remporter un prix LEGO®.

Offre soumise à conditions.

Al contestar, participarás automáticamente en el sorteo y podrás ganar un set LEGO®.

Sujeto a Términos y Condiciones.

完成我们的反馈调查，即可自动进入抽奖环节，赢取乐高®套装。

适用《条款和条件》。

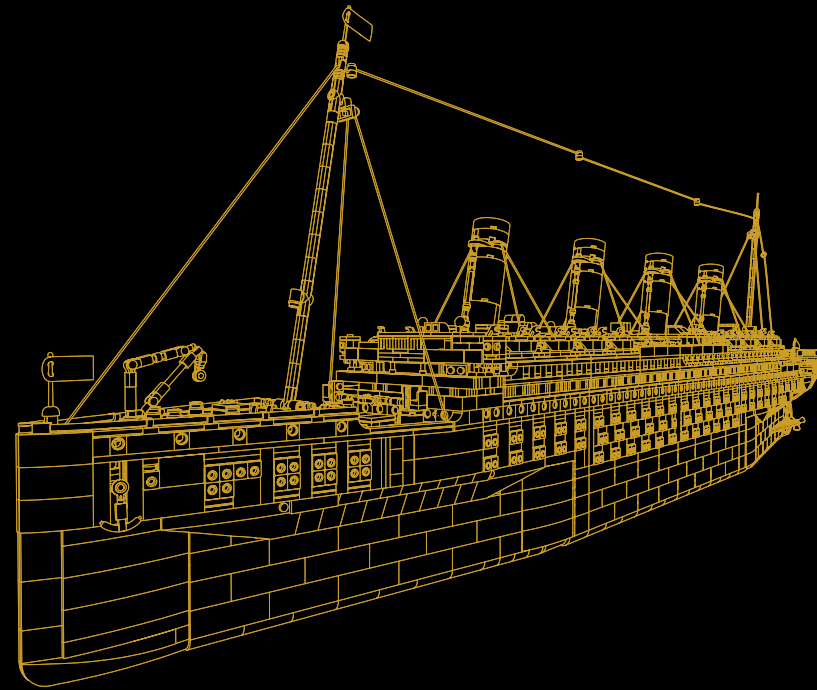

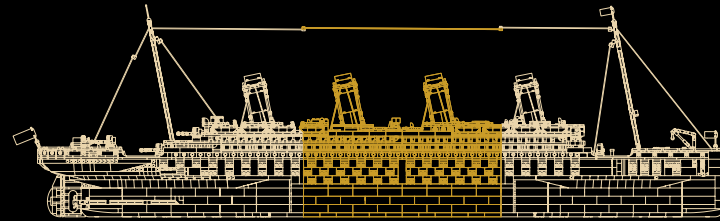

TITANIC

BOOK 2

THE WORLD'S MOST LUXURIOUS PASSENGER LINER

Designed to be the epitome of style, comfort and luxury, the *Titanic* aimed to convey the impression of being a floating hotel rather than a ship. It offered its 833 first-class passengers a vast range of facilities including an onboard gymnasium, squash court, swimming pool, libraries and exquisite restaurants and cabins. The ship's most distinctive feature was the *Grand Staircase*, built in solid oak, that descended in a sweeping curve down through seven decks of the liner.



↑ The Aft First-Class staircase leading to the a la carte restaurant.

→ 2nd-Class dinner menu dated 14 April 1912, the date that Titanic struck the iceberg that caused her to sink.

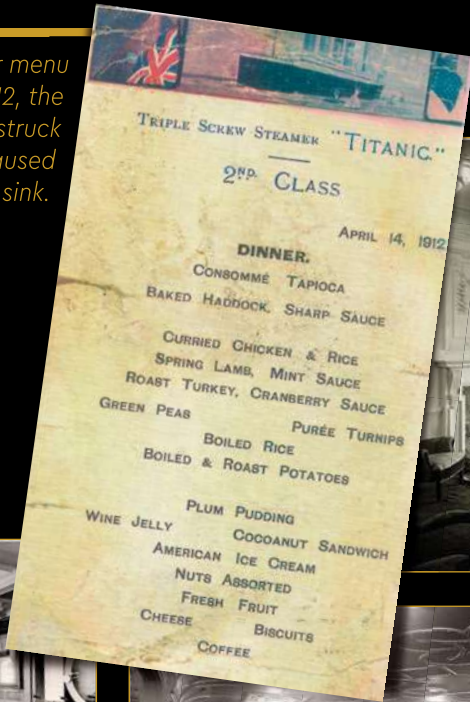

↓ Reading room on the upper promenade.



↓ The First-Class Lounge.



↓ The First-Class gymnasium.

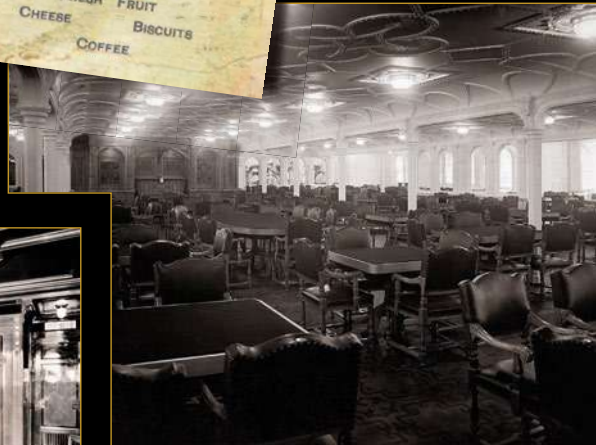

↑ Main dining room.



↑ Café Parisien, an extension to the First-Class restaurant.



↑ The elegant splendour of First-Class parlour suite B57.

BUILDING THE TITANIC

What started out as a concept model during a free-build session for LEGO® designers quickly developed into one of the largest LEGO sets ever created. The impressive size was, however, never the goal in itself; instead, it grew in scale as the design team came up with a host of intricate details they felt had to be included in the model. For veteran LEGO Designer Mike Psiaki, this included creating replica steam engines with moving pistons using LEGO Technic elements. Once the initial design was in place, the team sat for an entire week building different versions of the model, deciding what needed to be strengthened or simplified.



↑ Some of the LEGO® team on this model (from left to right): Senior Model Coach, Torben Kidde Skov, Design Master, Mike Psiaki, Senior Building Instruction Specialist, Martin Højen Holm Buk



[LEGO.com/brickseparator](https://www.lego.com/brickseparator)

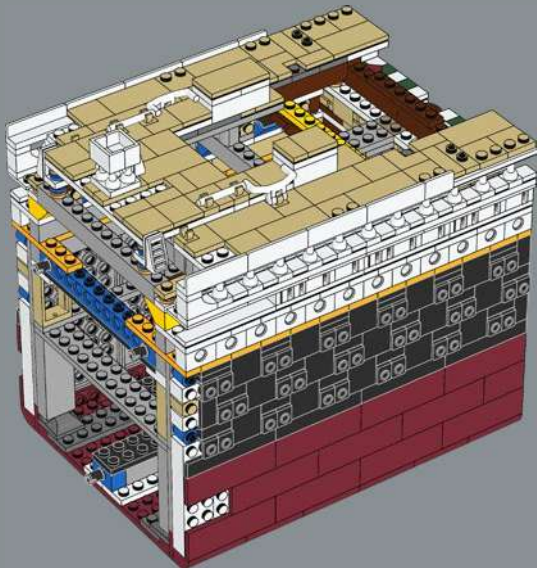
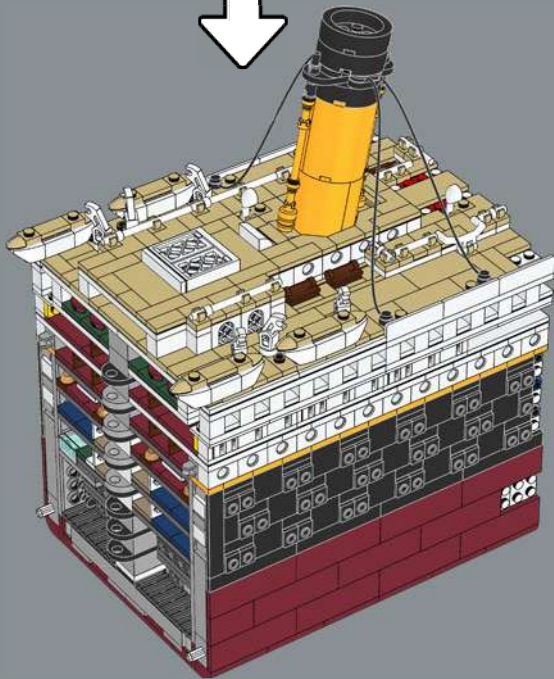

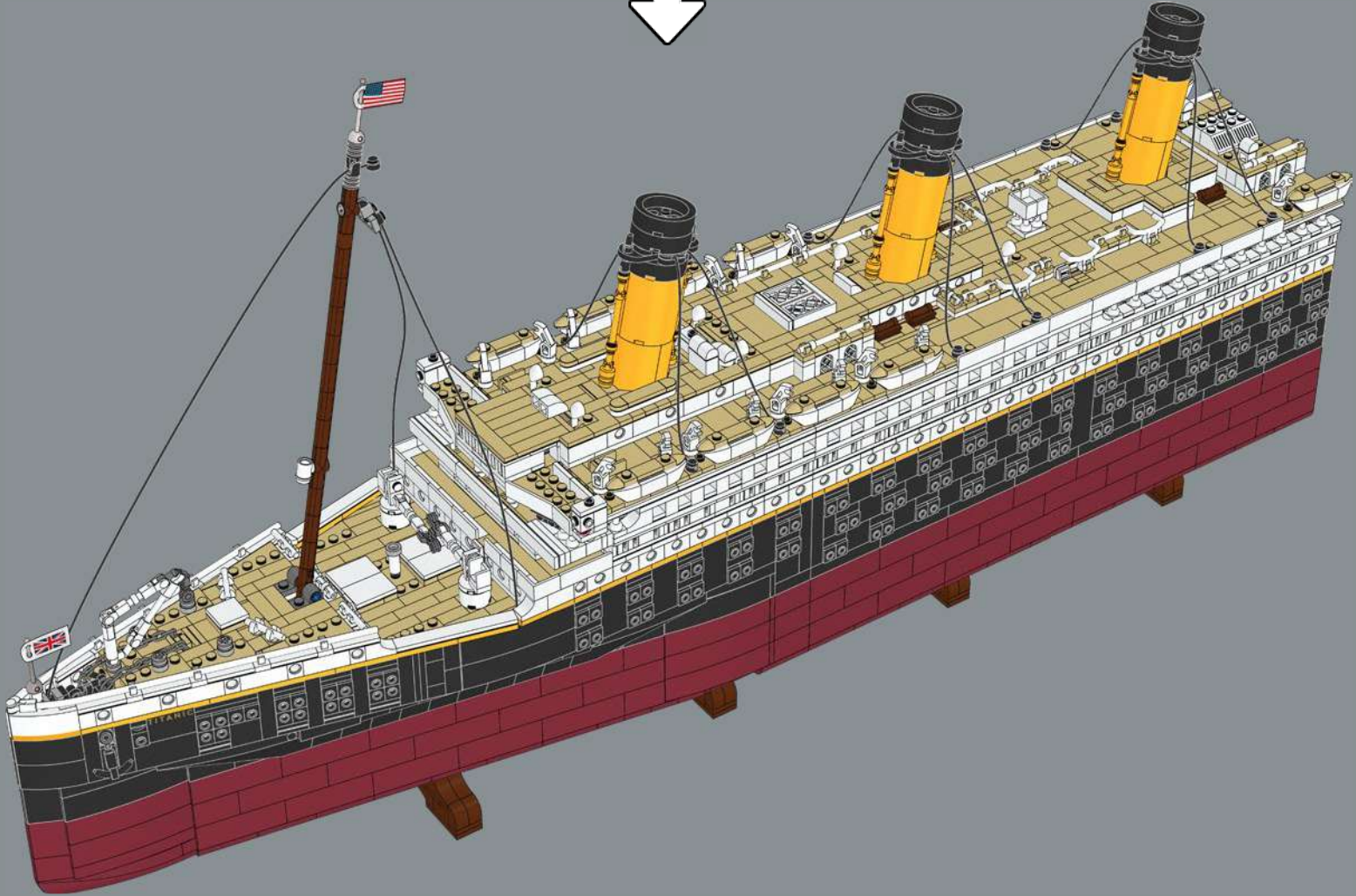
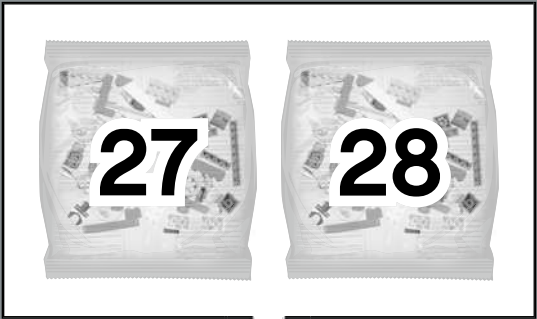

↓ The second half of the locking mechanism that holds the 3 main sections of the ship together is built here.

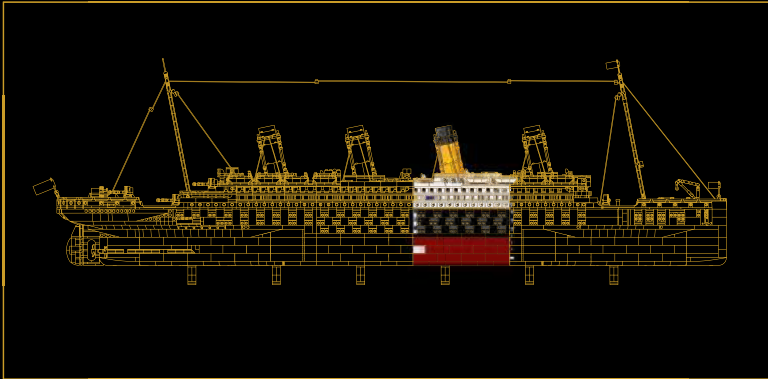

SECTION 3:

FUNNEL & MAIN CABINS

Here you will build another cross section of the ship, including some of its coal bunkers in the lowest decks, plus numerous cabins of various classes. The superstructure of this section contains the beginnings of the ship's promenade decks as well as the skylight for the grand staircase and second funnel.



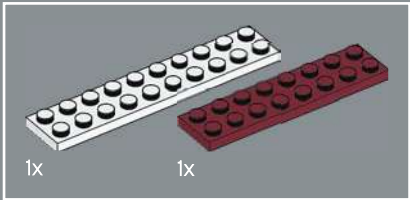
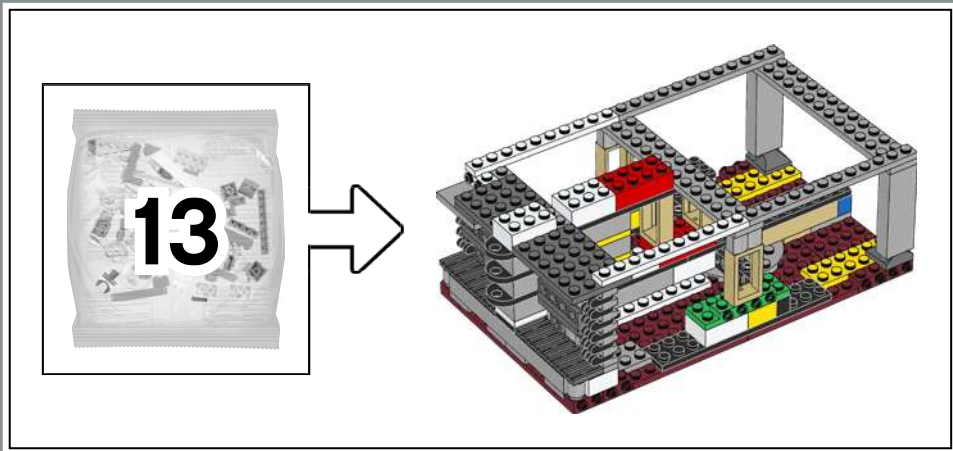

1

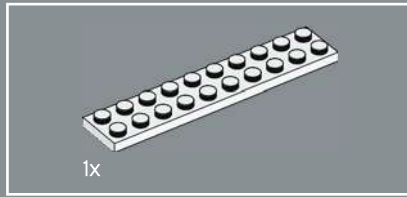
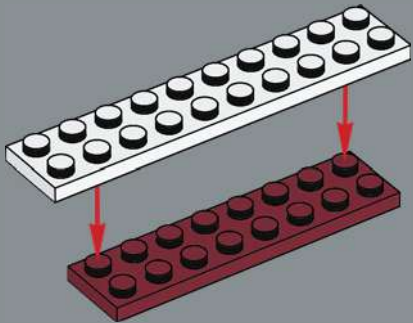

2

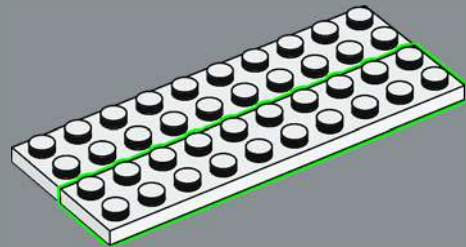

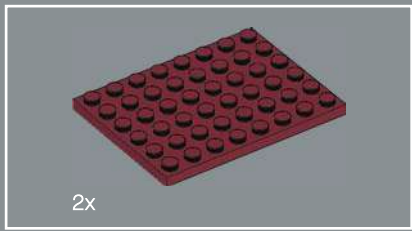

3

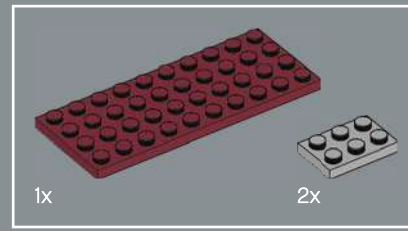
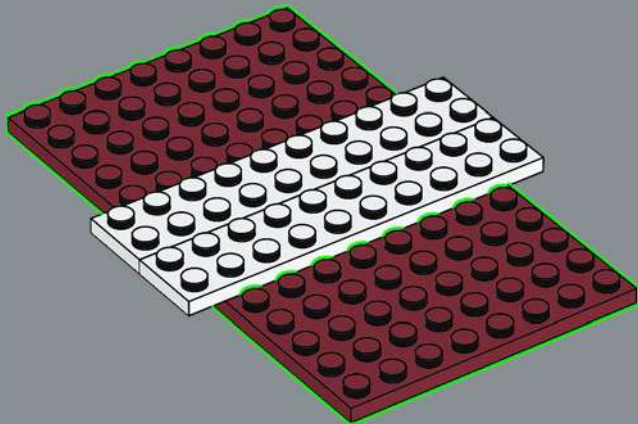

4

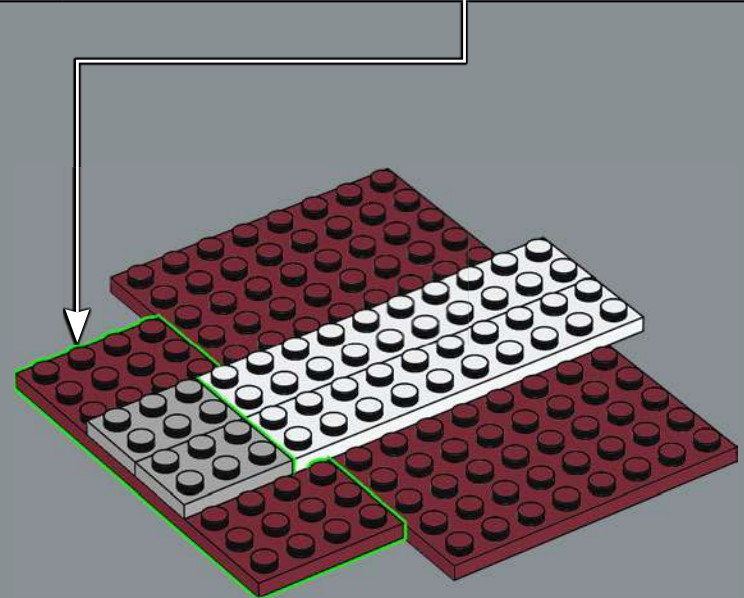
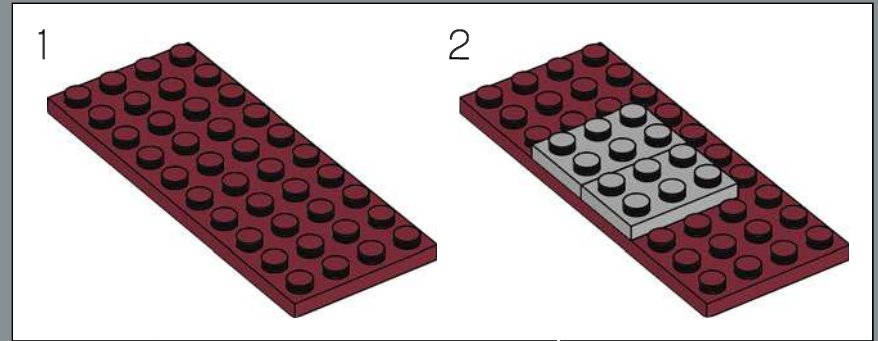

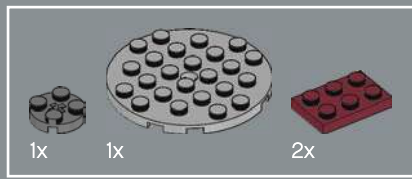

5

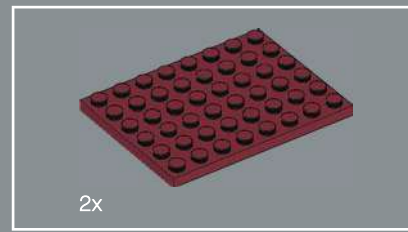
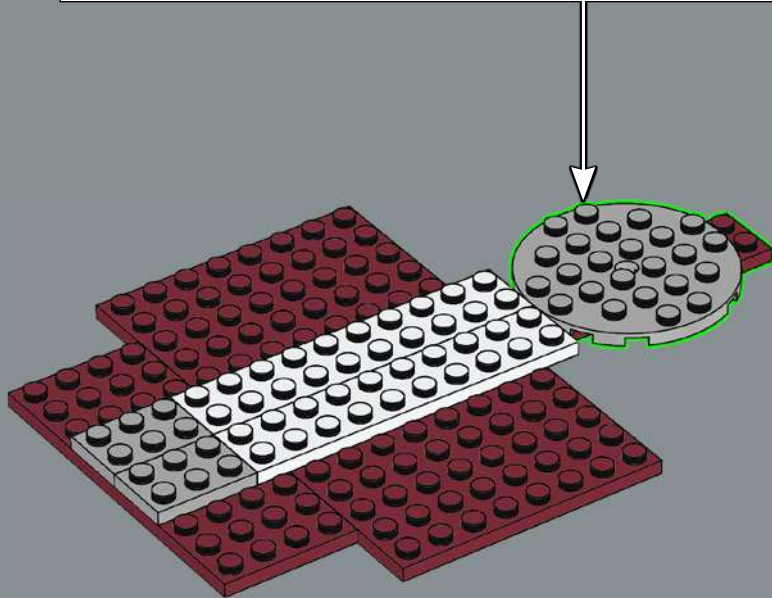
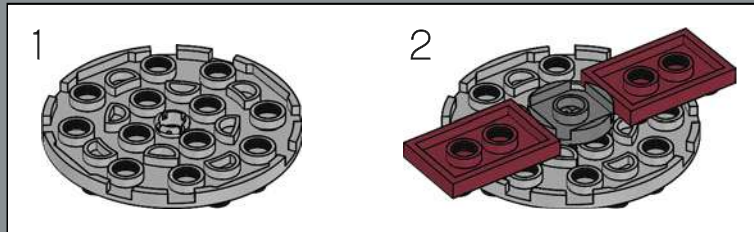

6

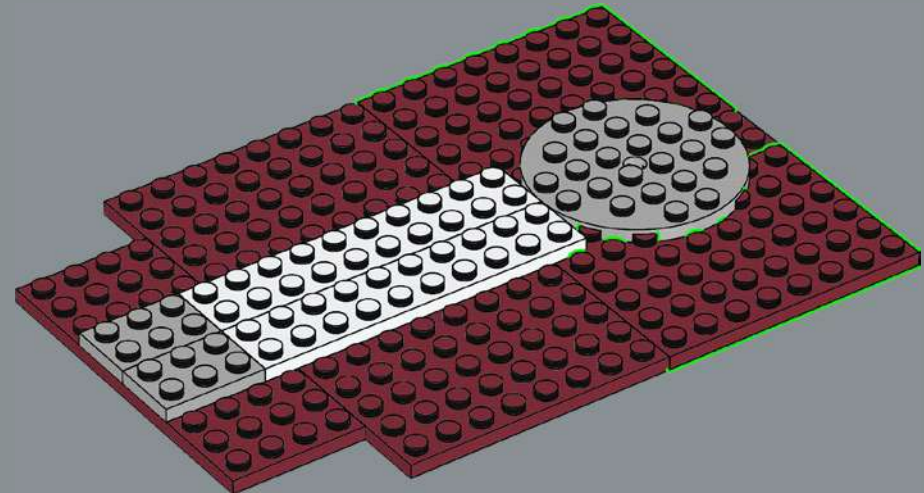

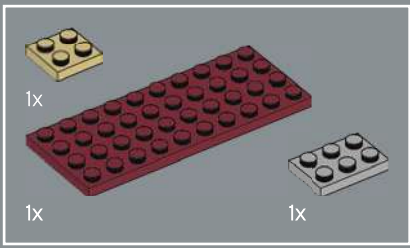

7

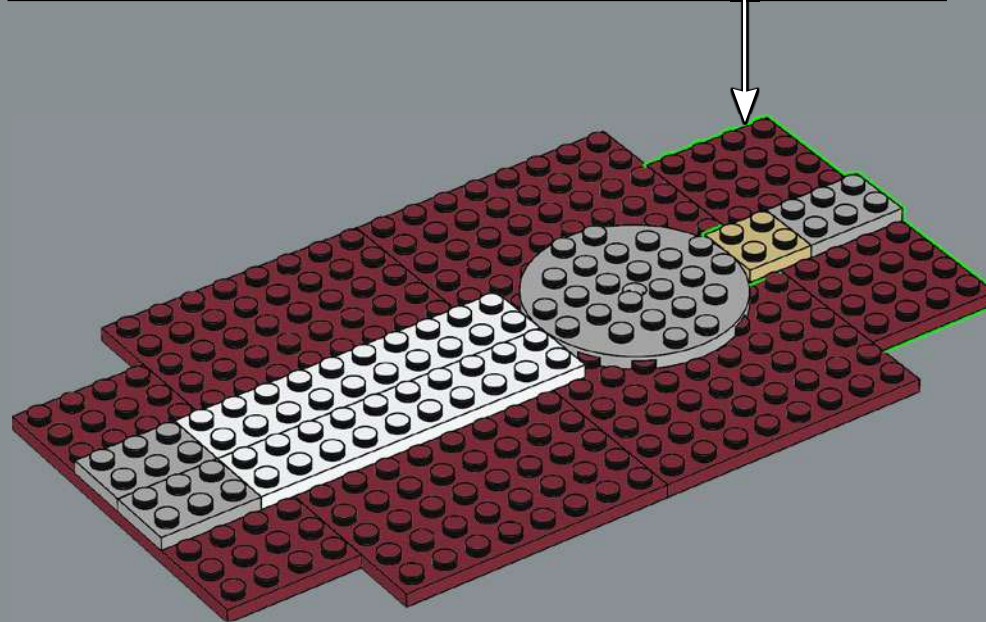
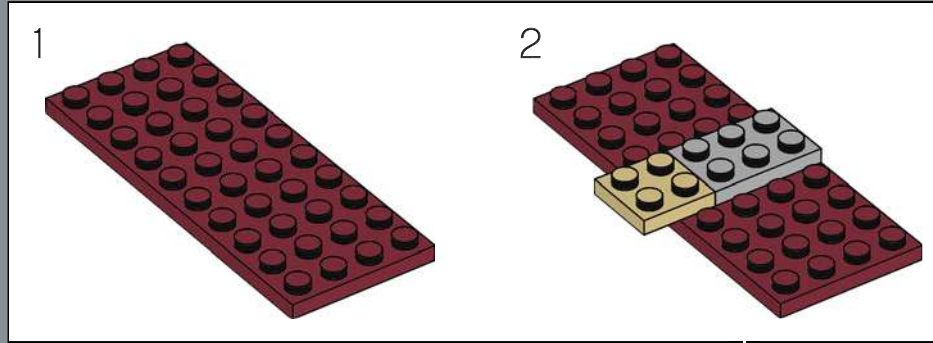

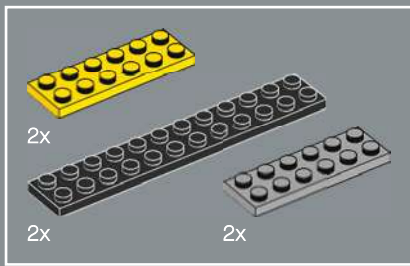

8

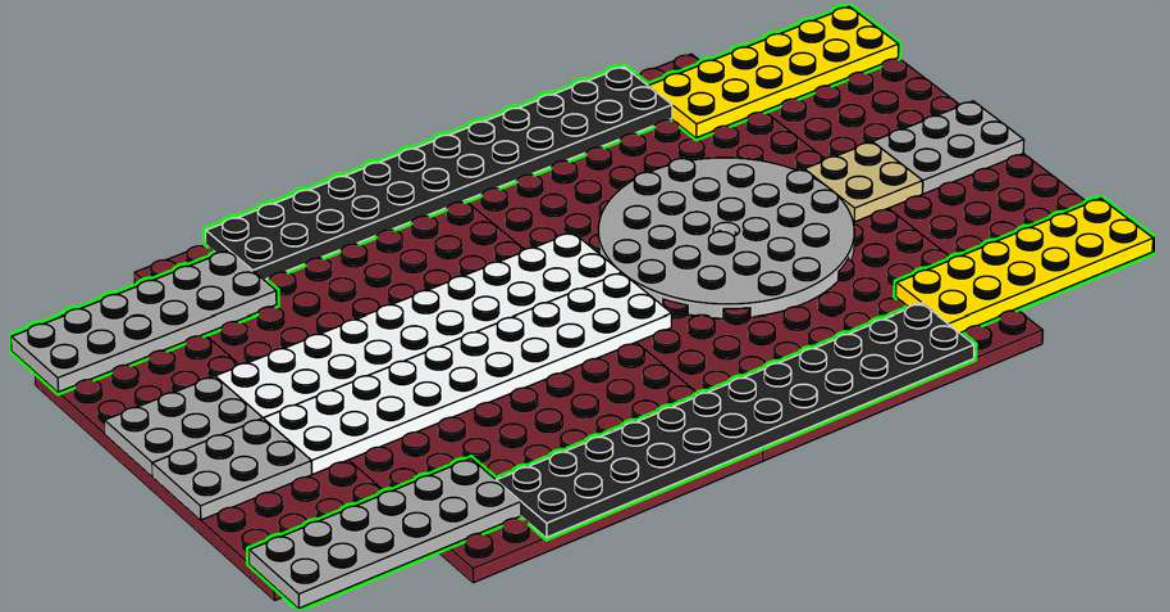

9

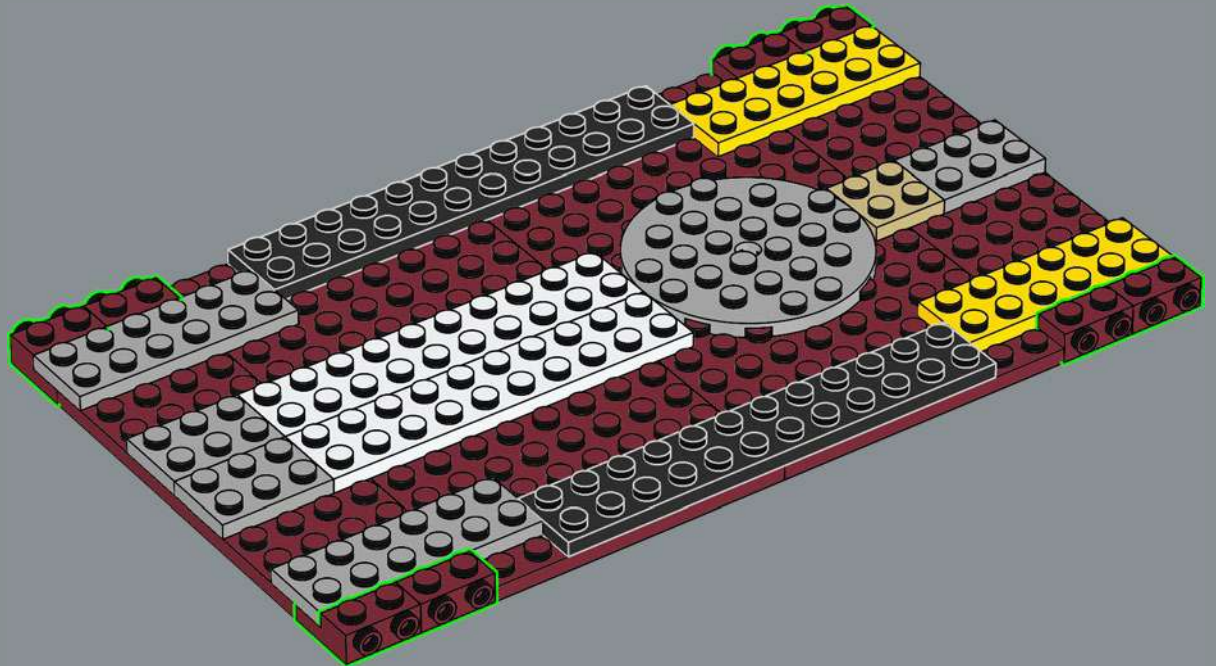

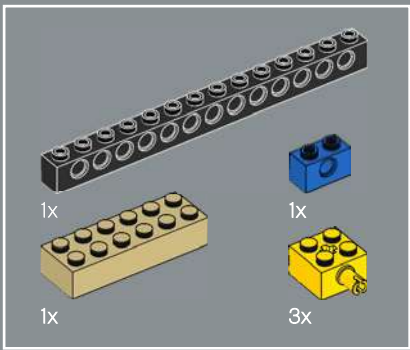

10

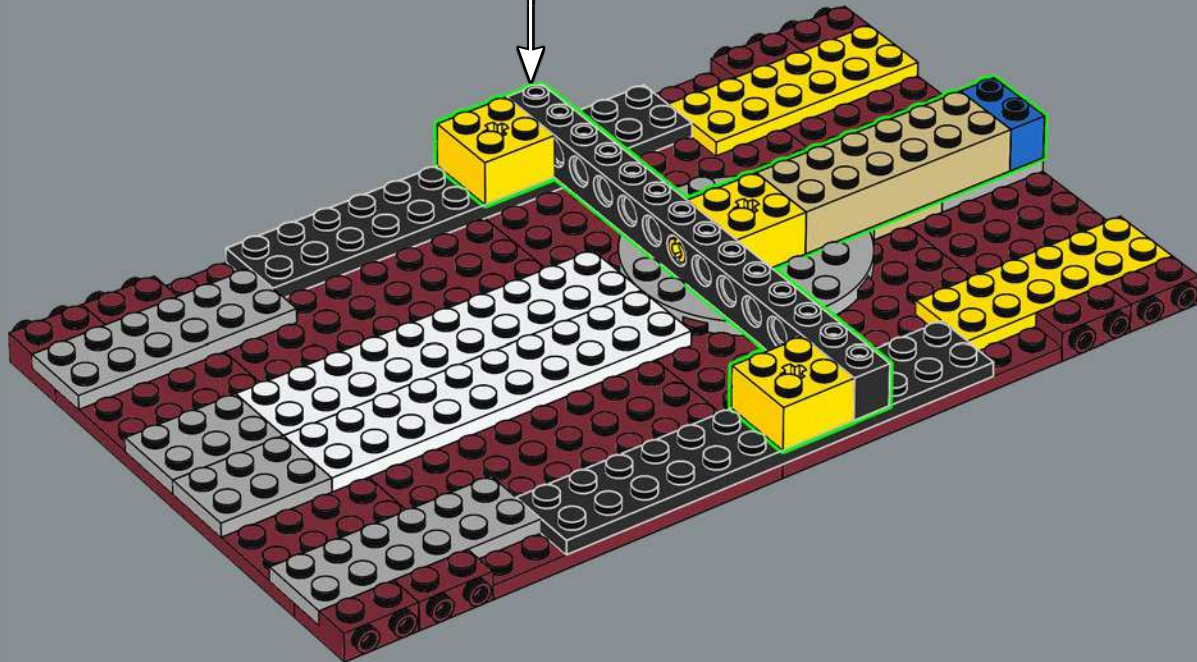
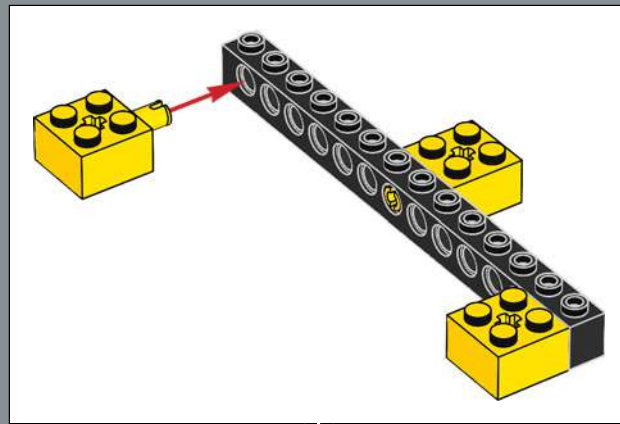

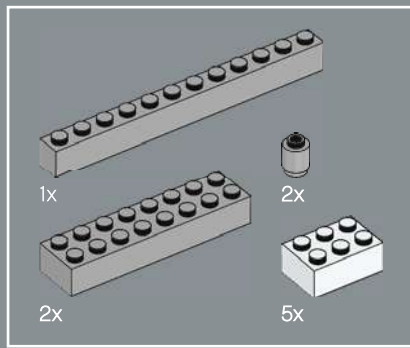

11

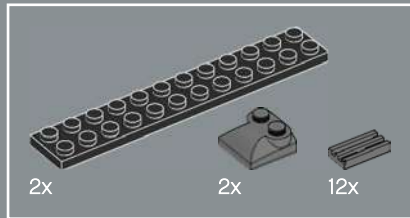
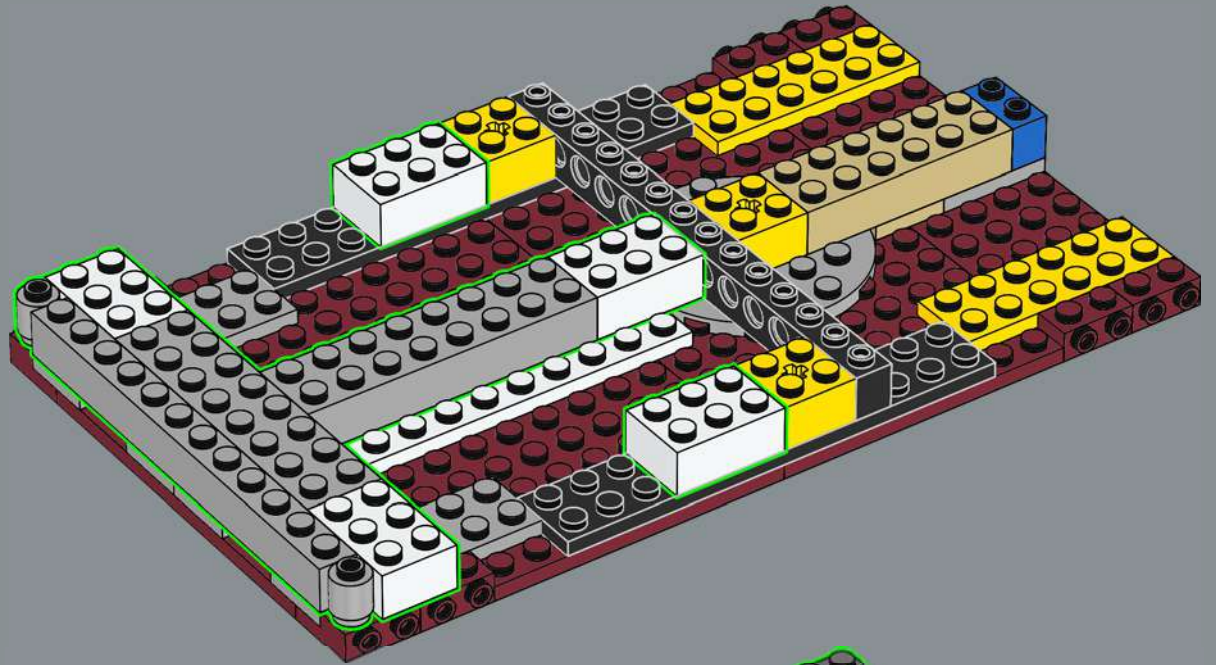

12

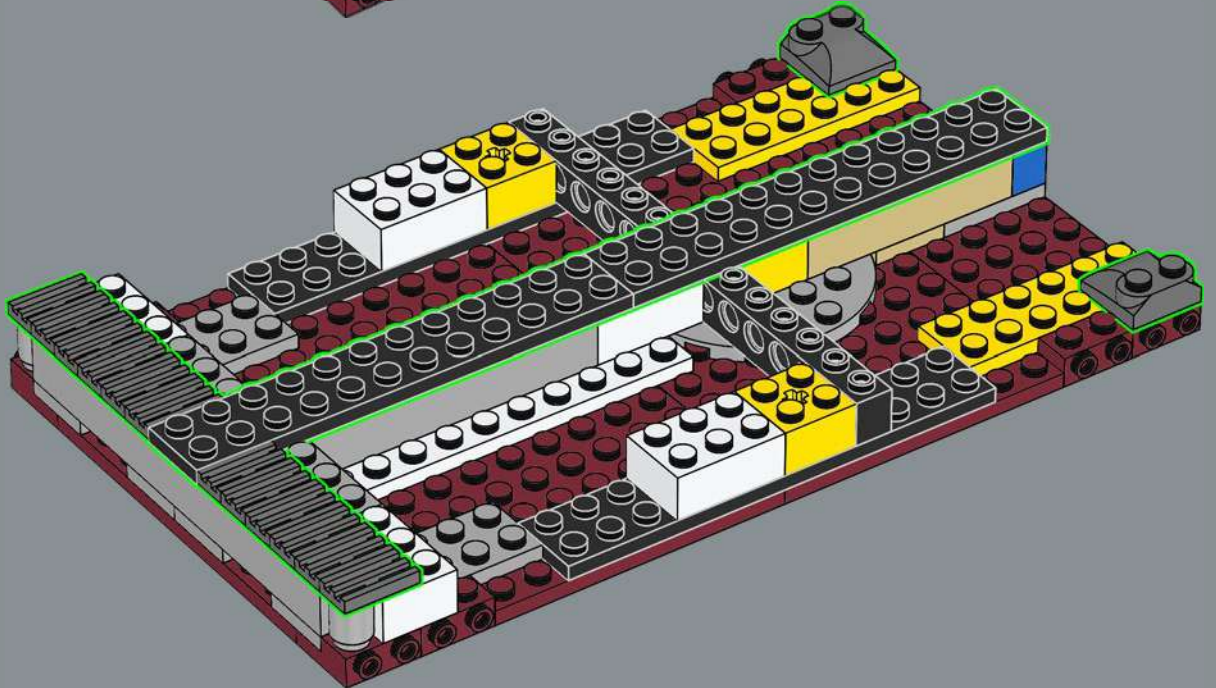

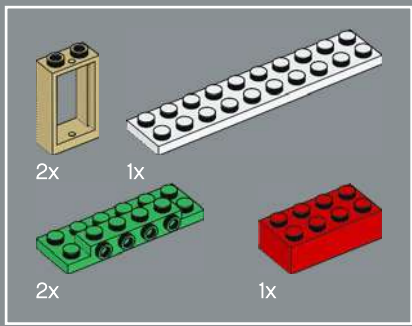

13

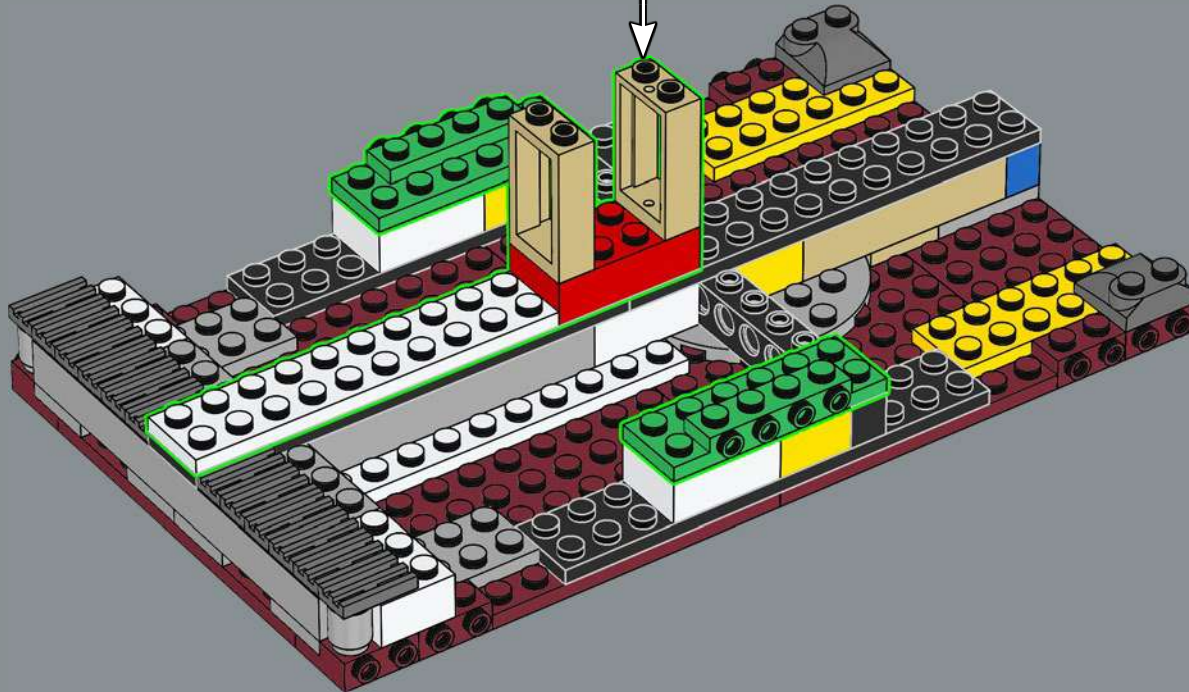
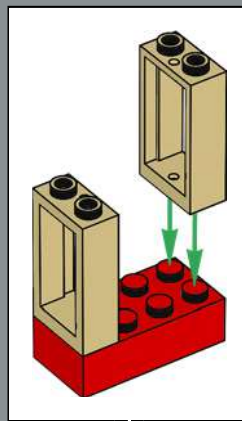

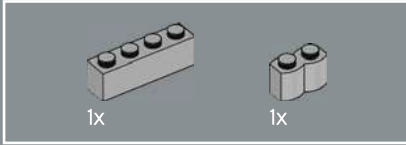
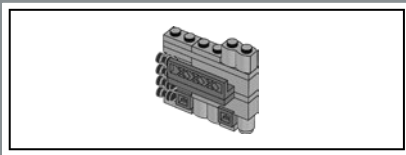

14

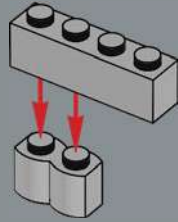

15

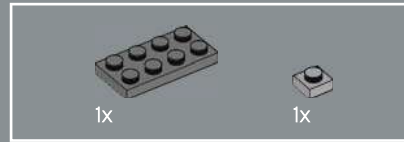
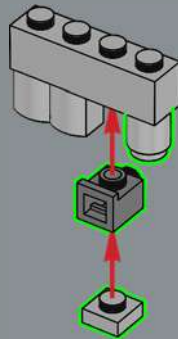

16

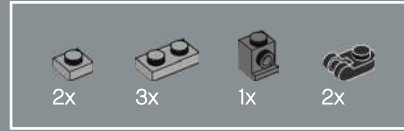
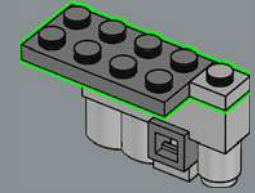

17

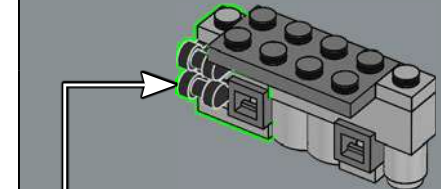
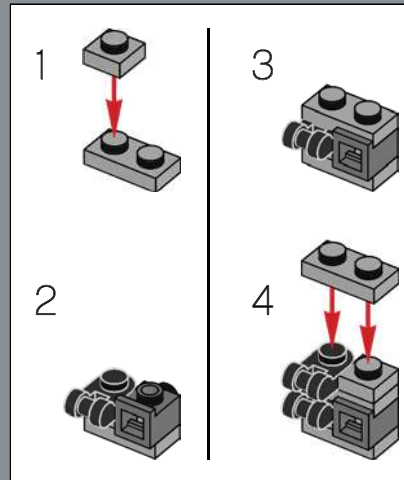



18

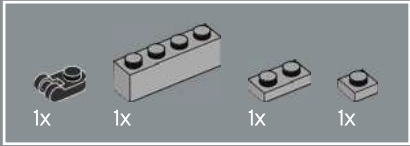
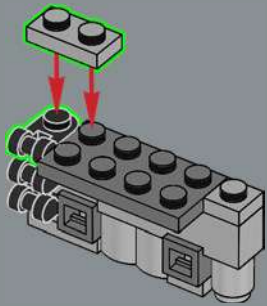

19

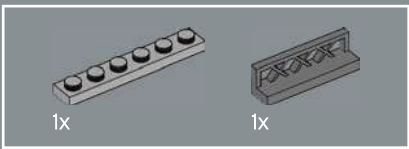
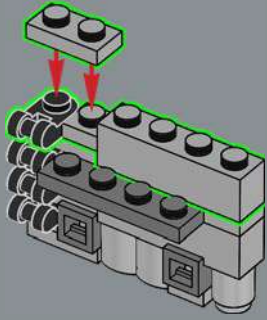

20

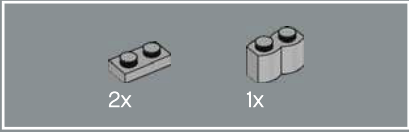
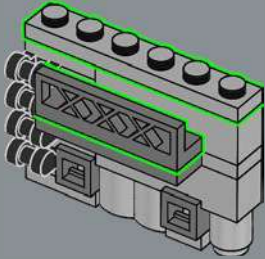

21

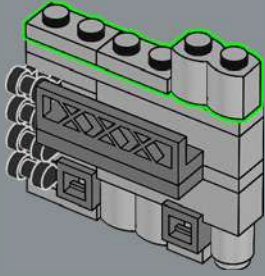

22

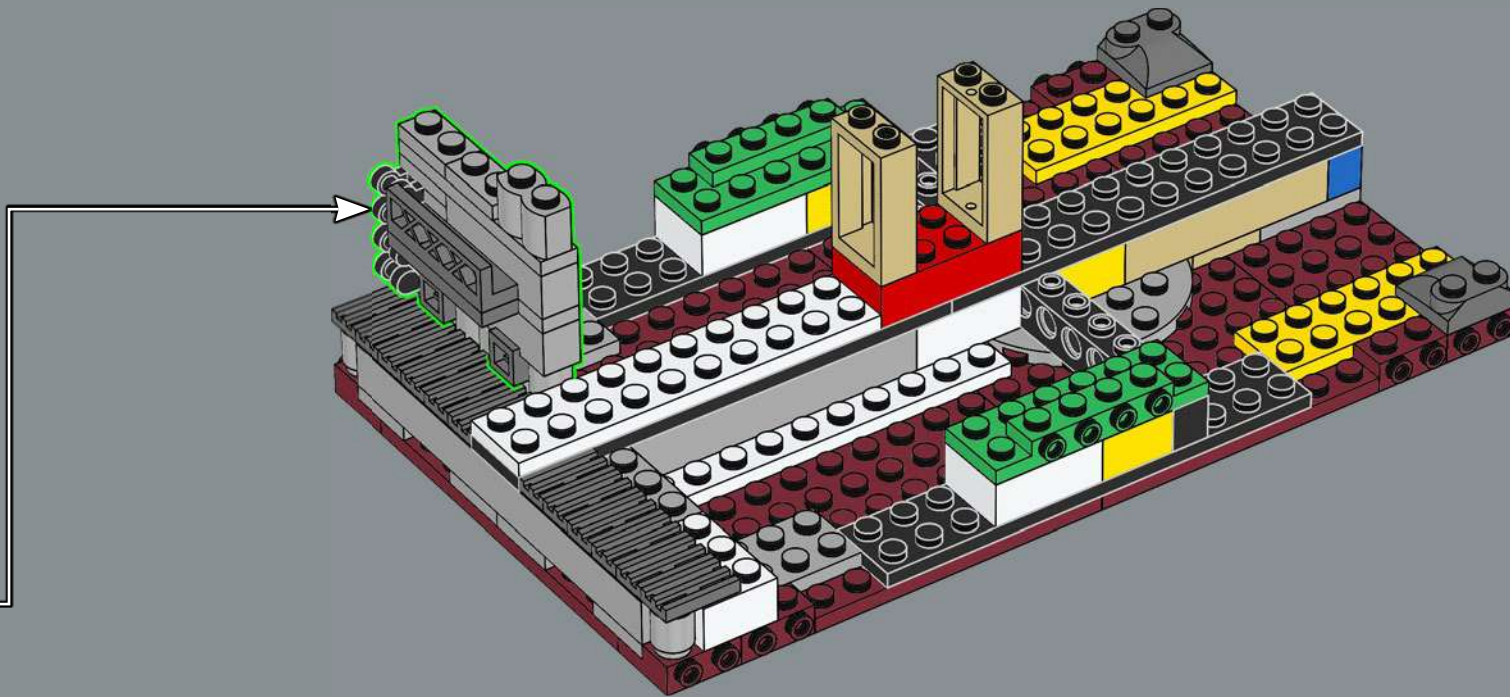

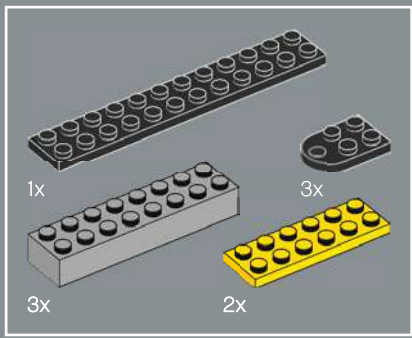

23

1

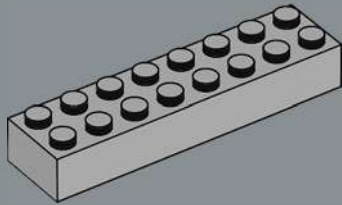

2

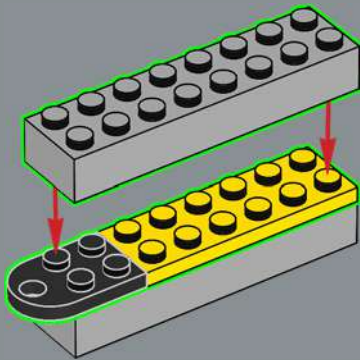

3

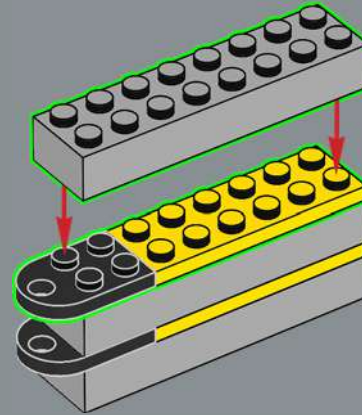

4

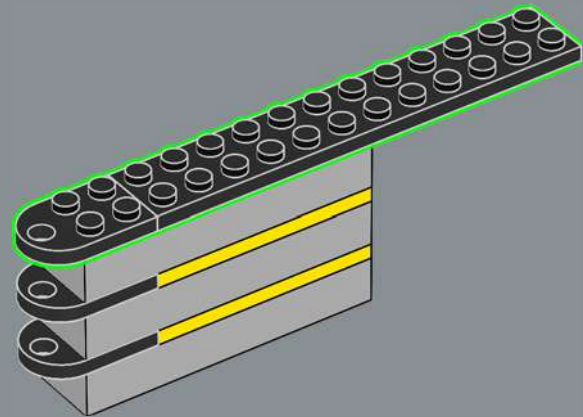

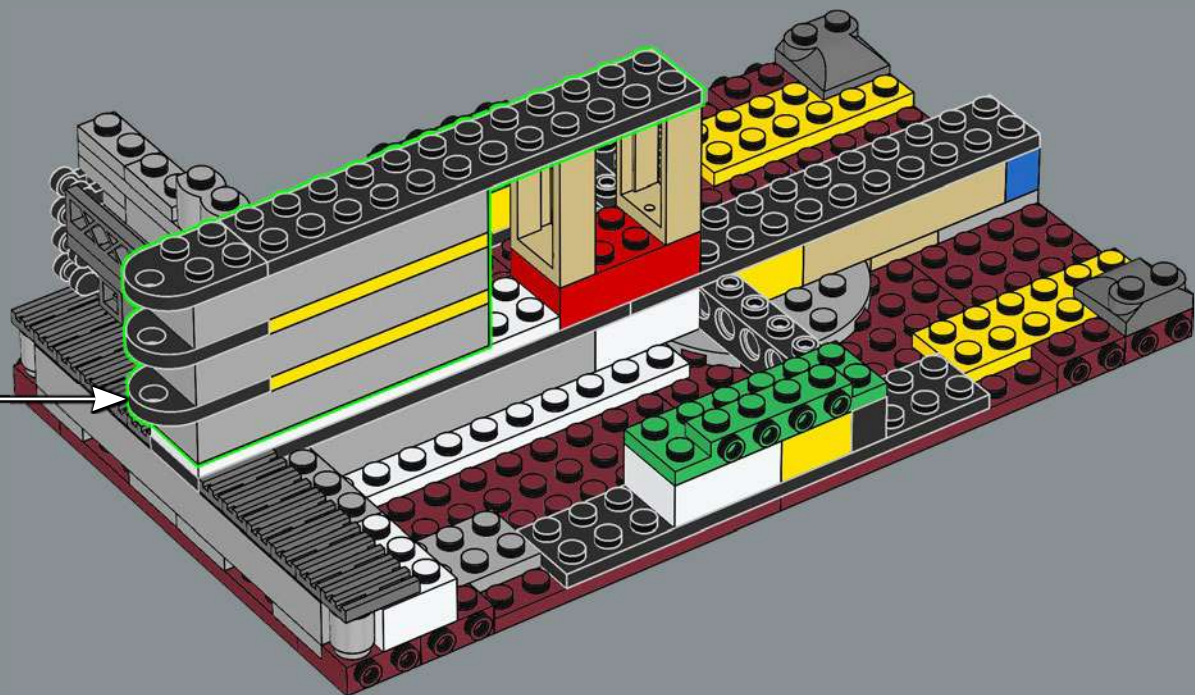

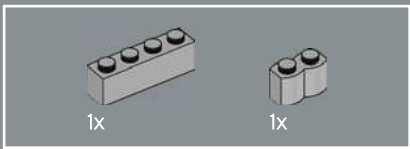

24

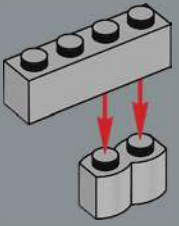

25

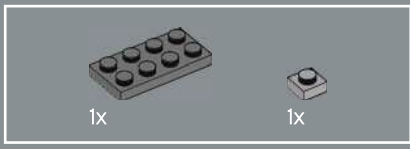
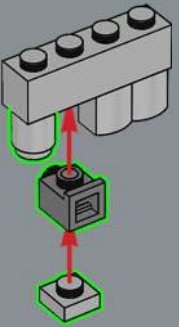

26

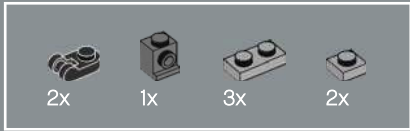
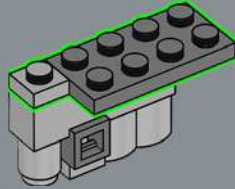

27

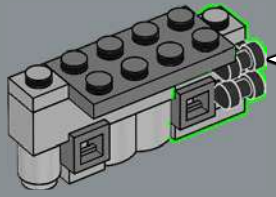
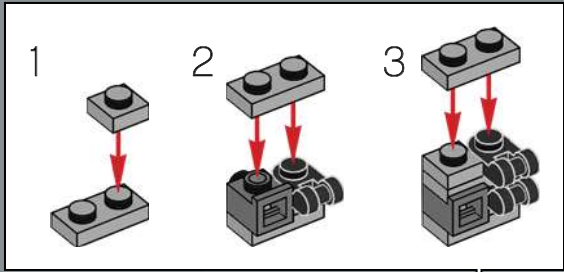

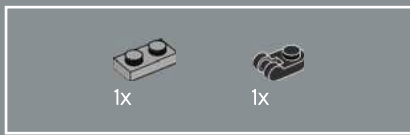

28

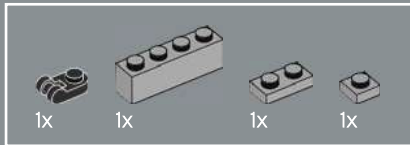
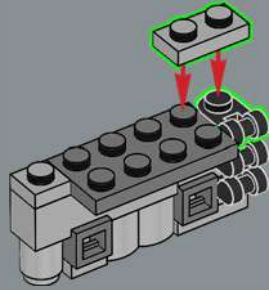

29

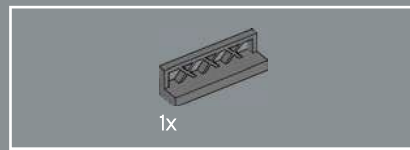
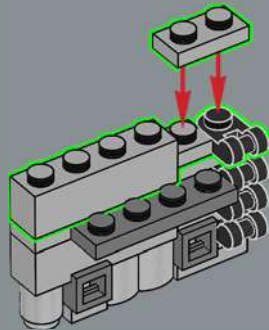

30

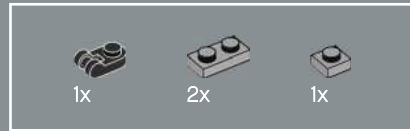
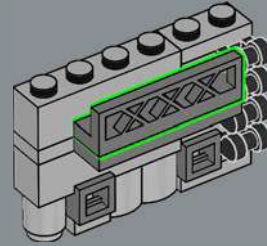

31

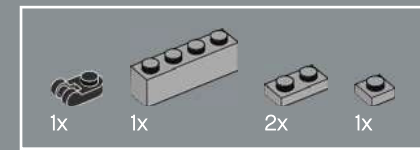
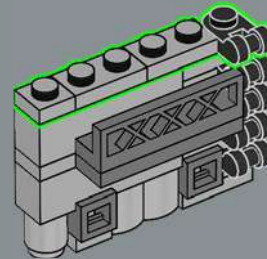

32

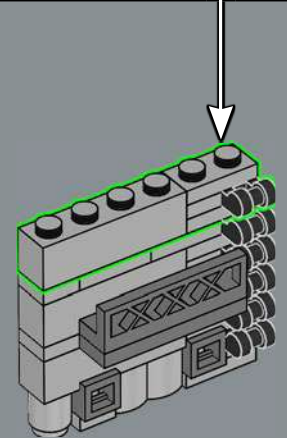
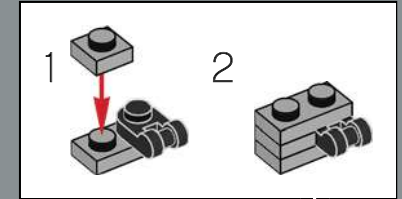

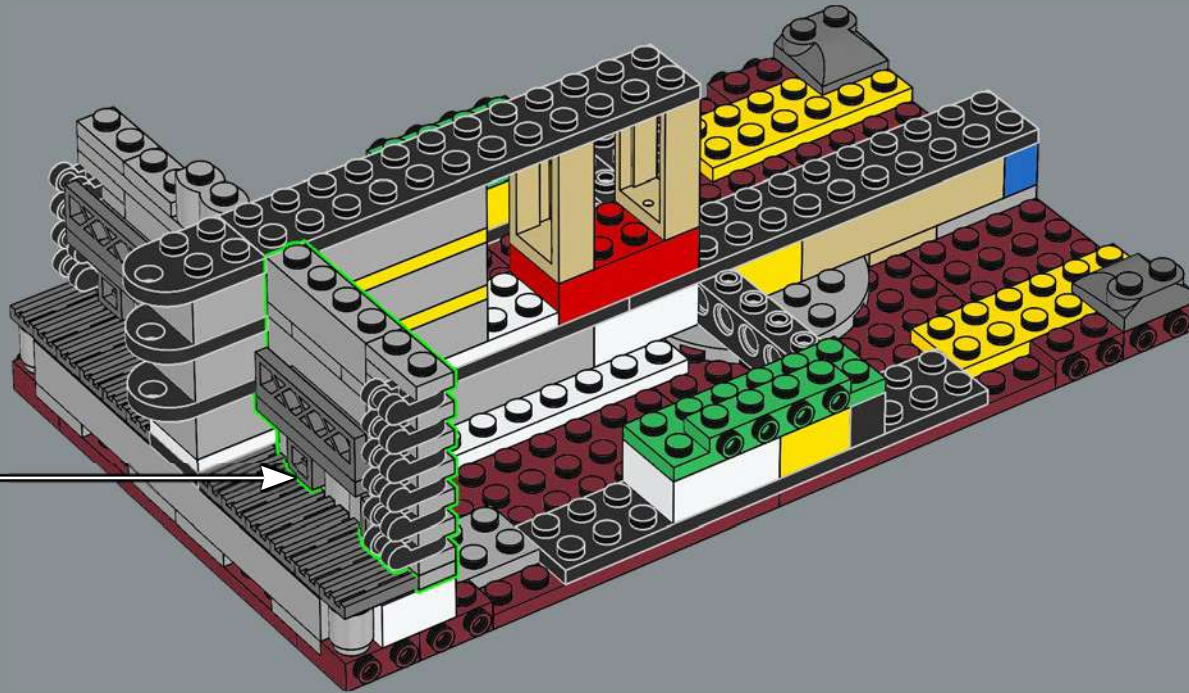

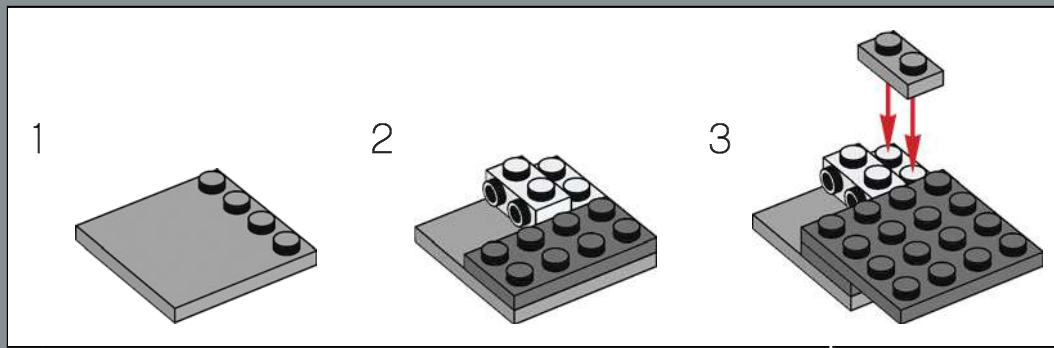
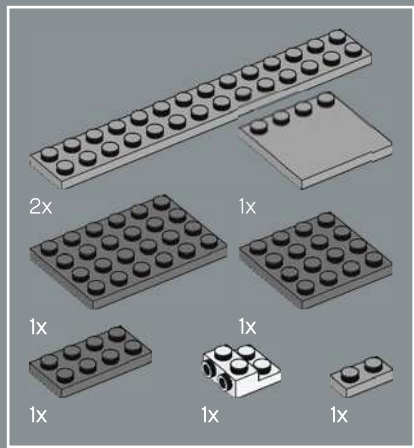

35

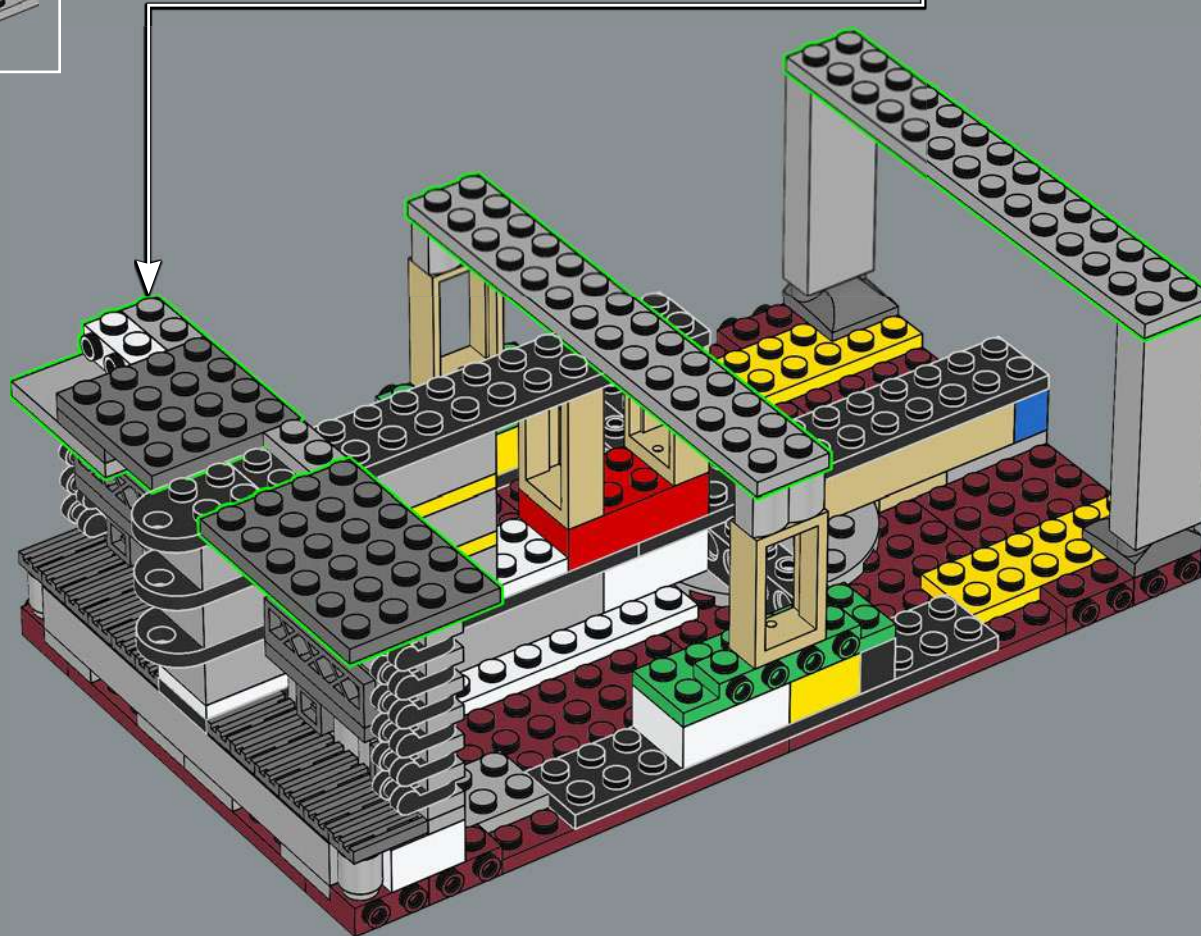

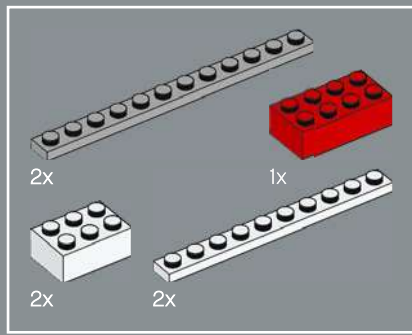

36

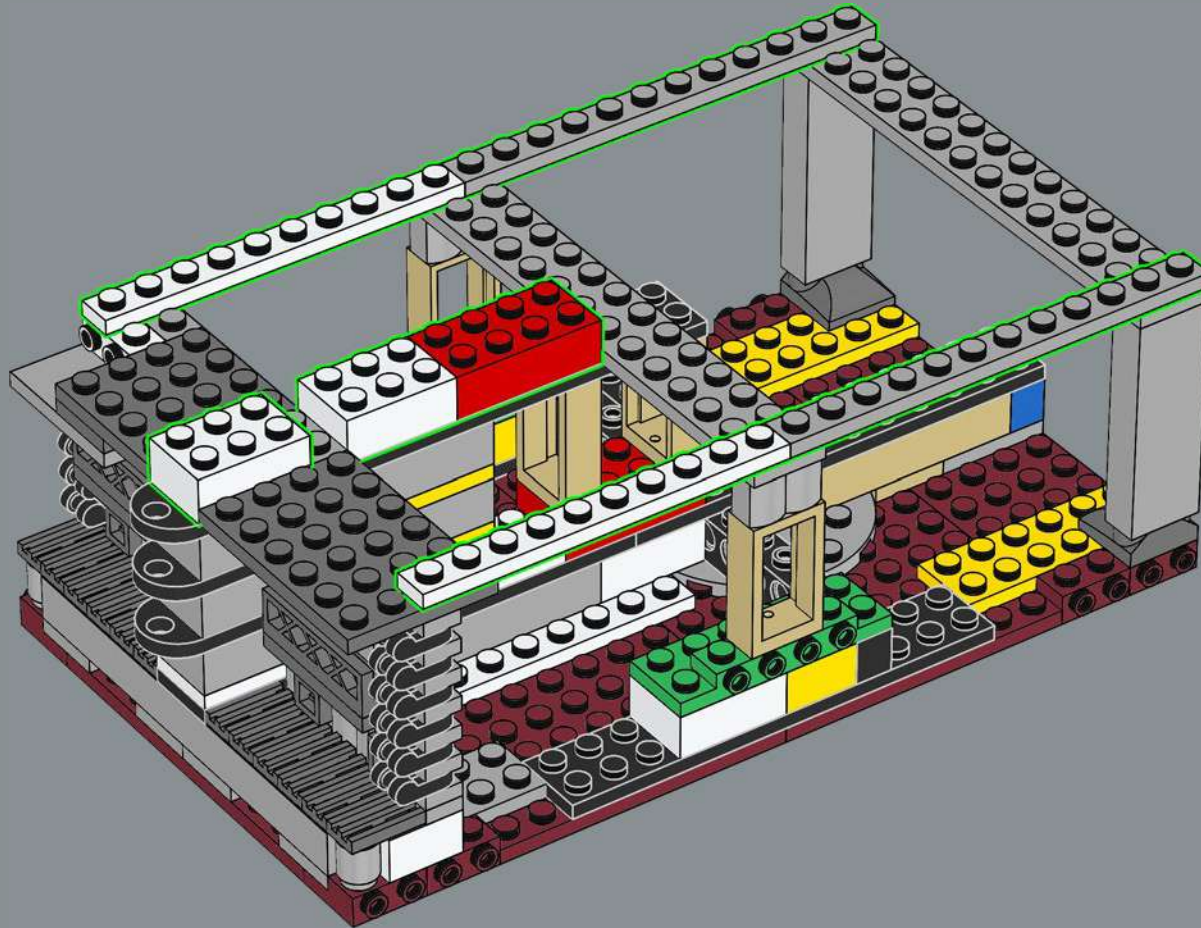

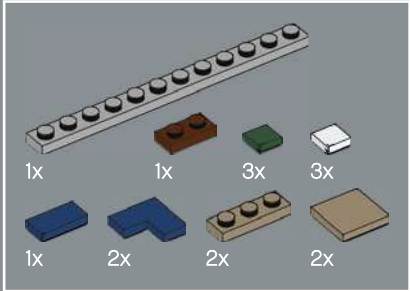
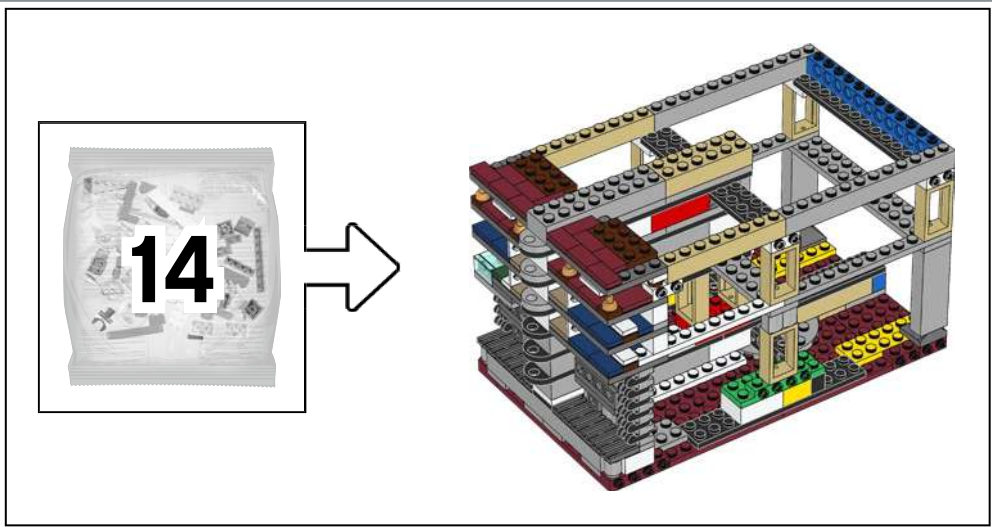

37

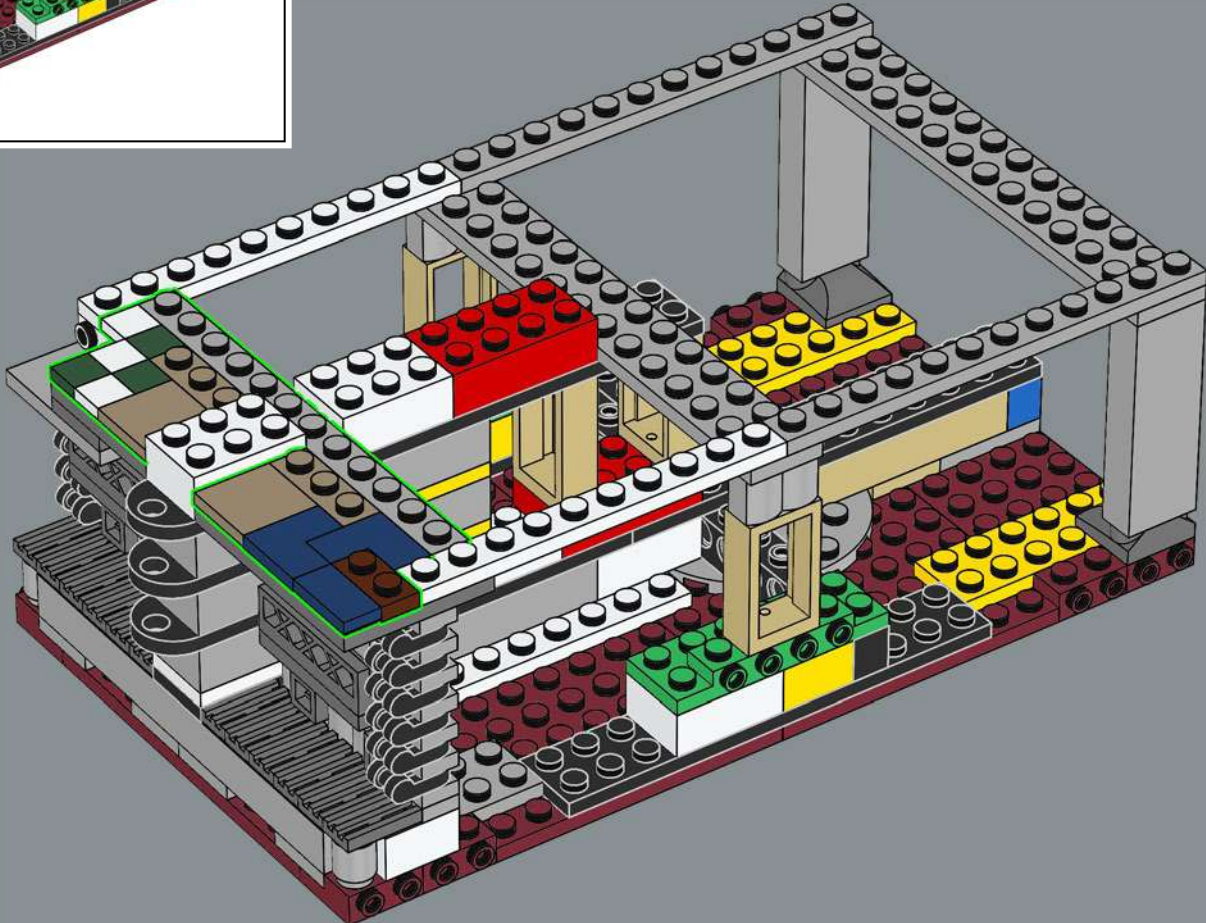

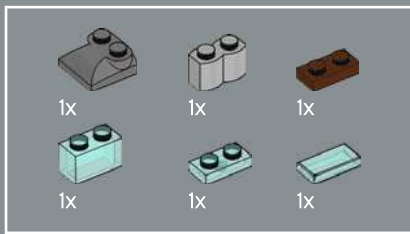

38

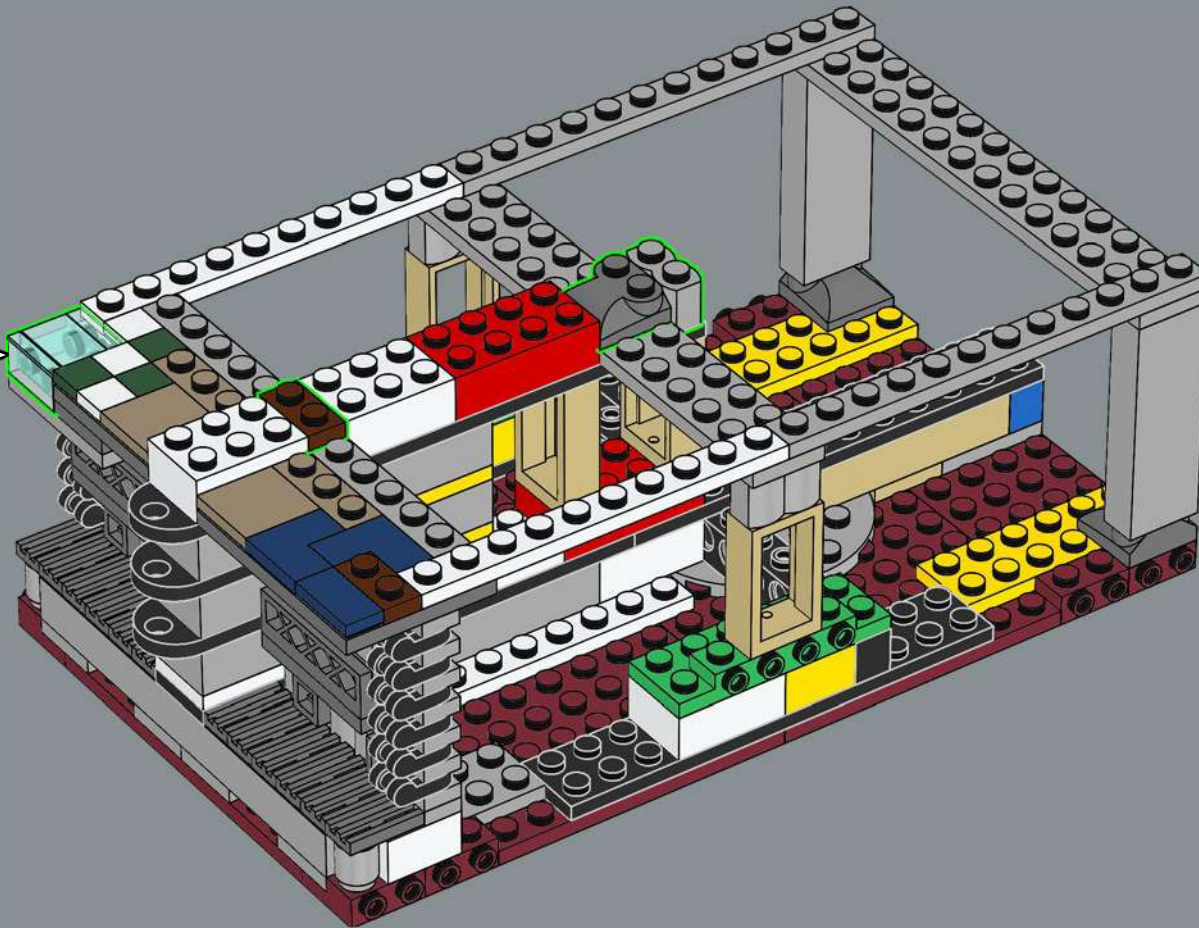
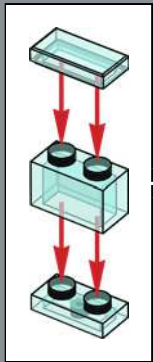

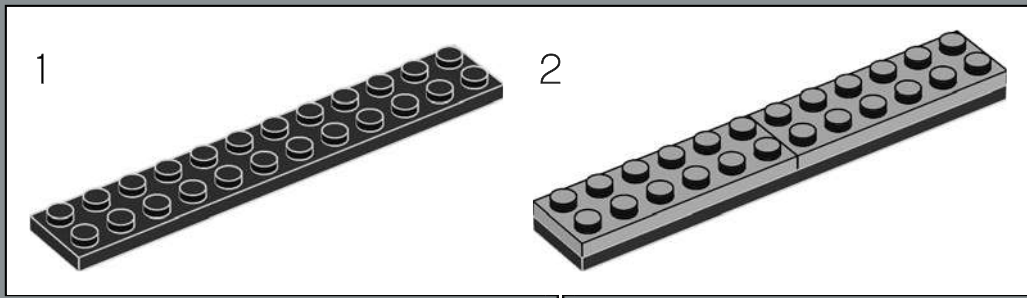
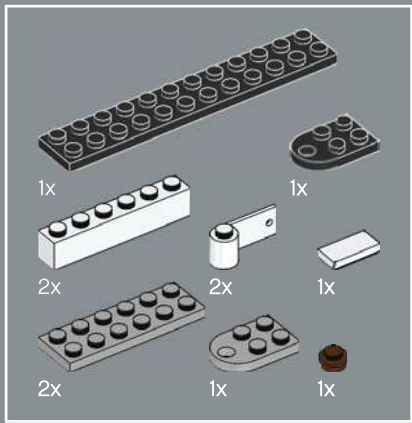

39

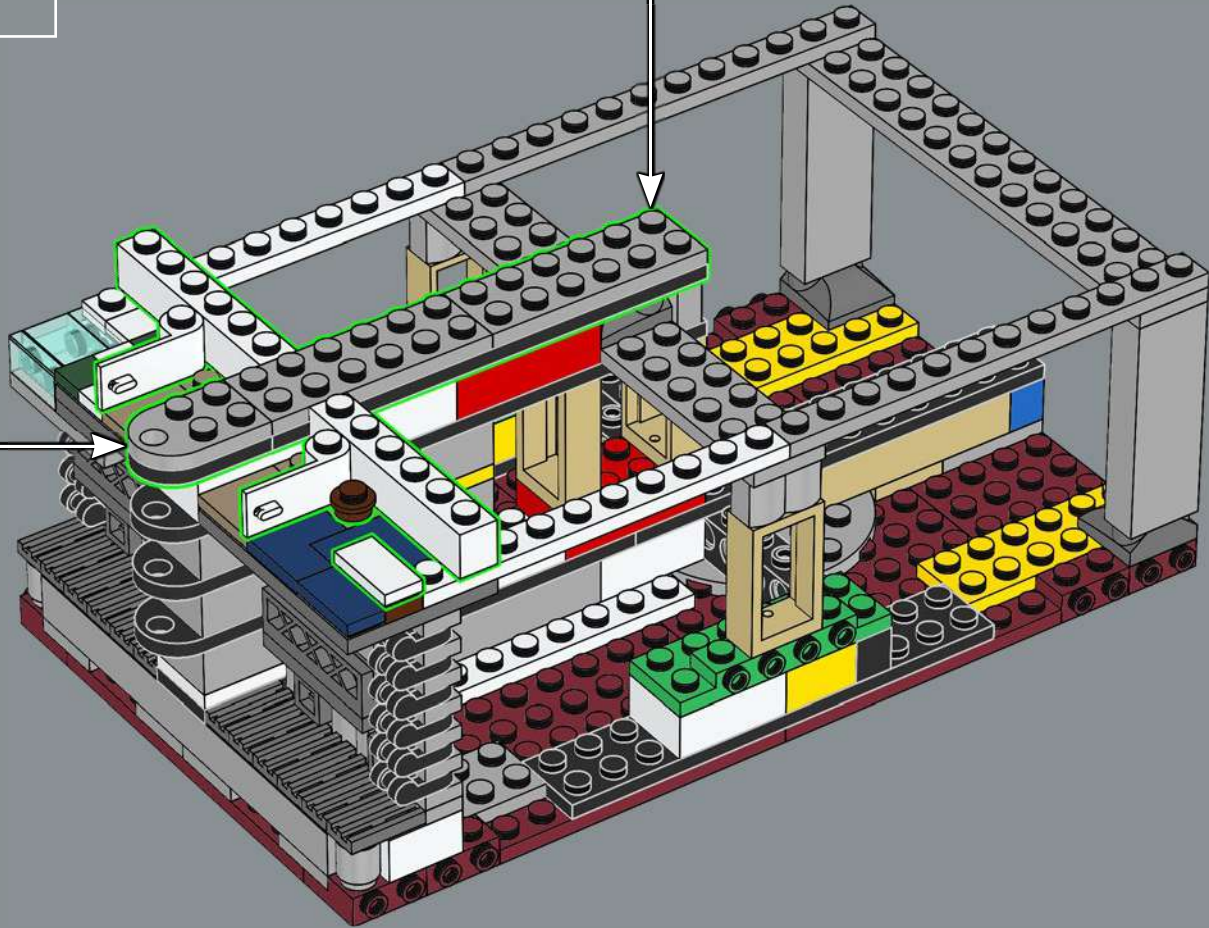
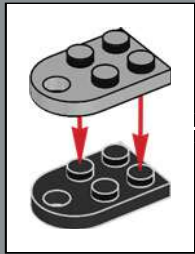

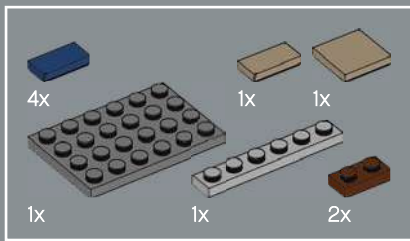

40

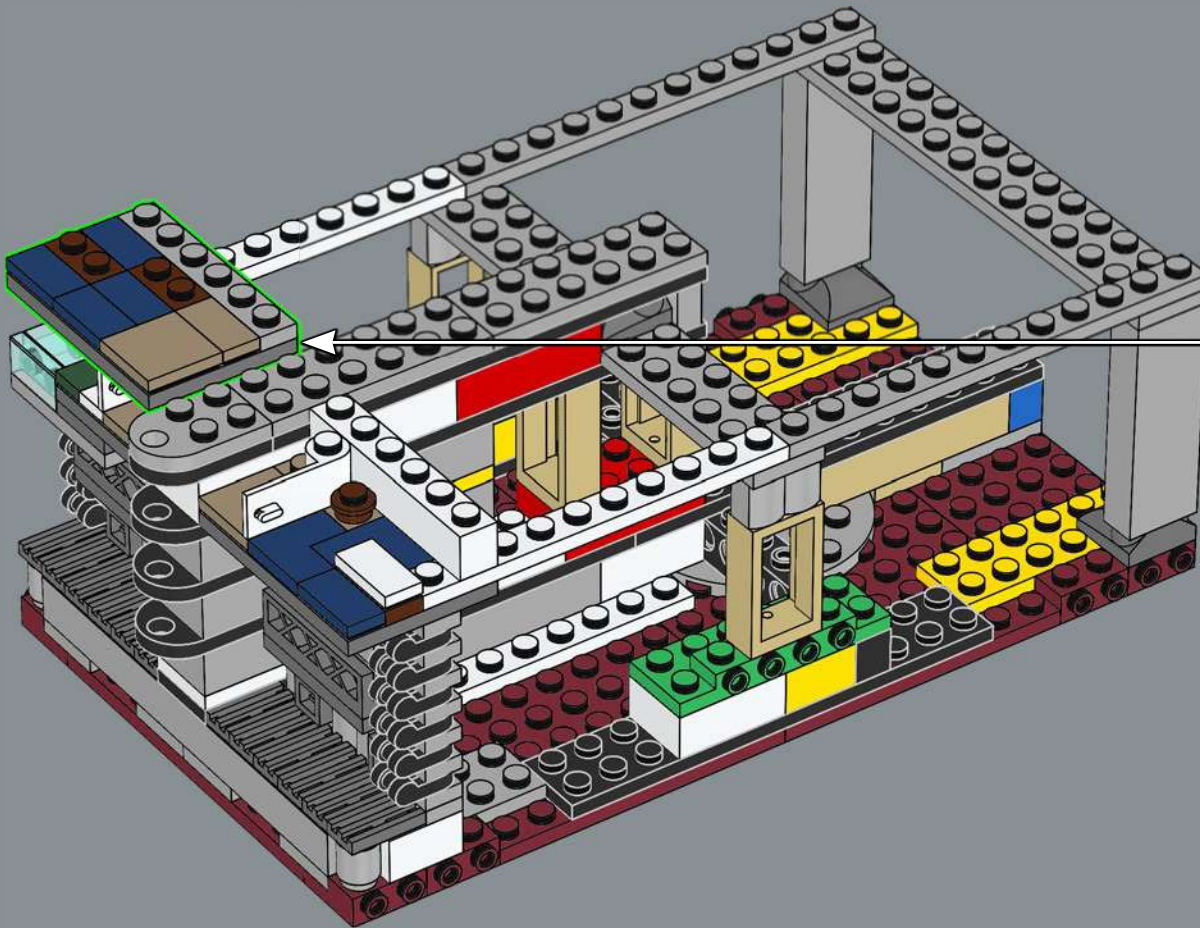
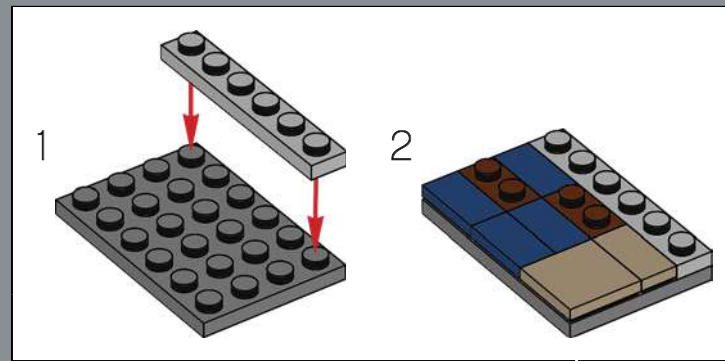

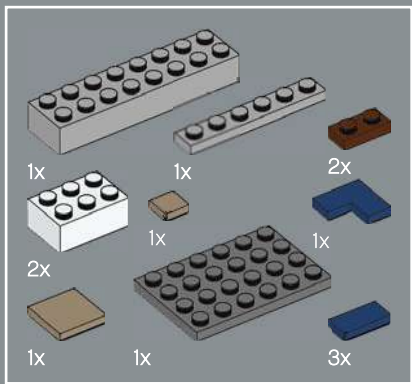

41

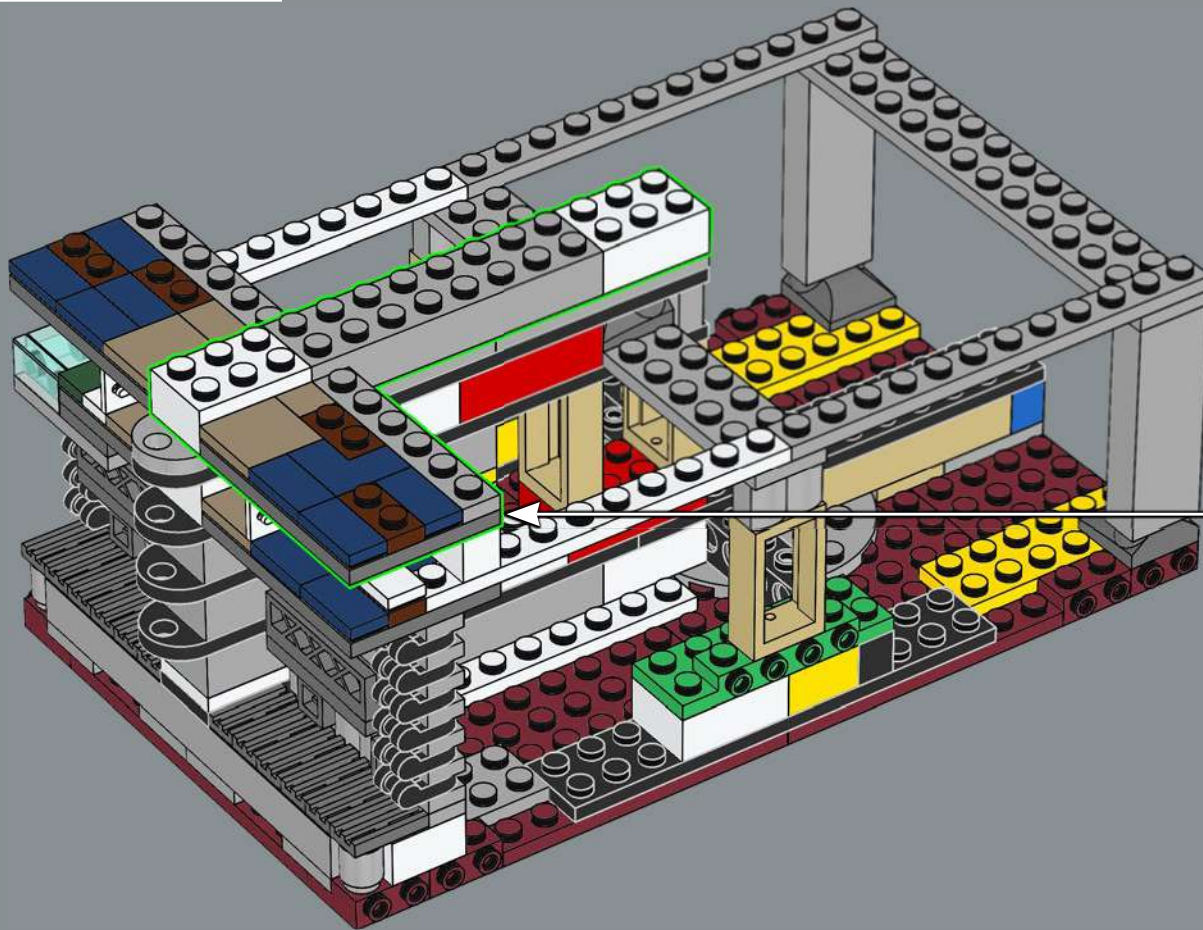
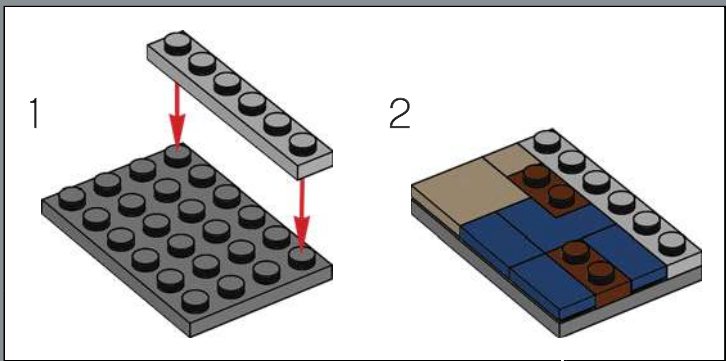

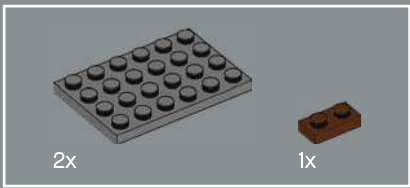

43

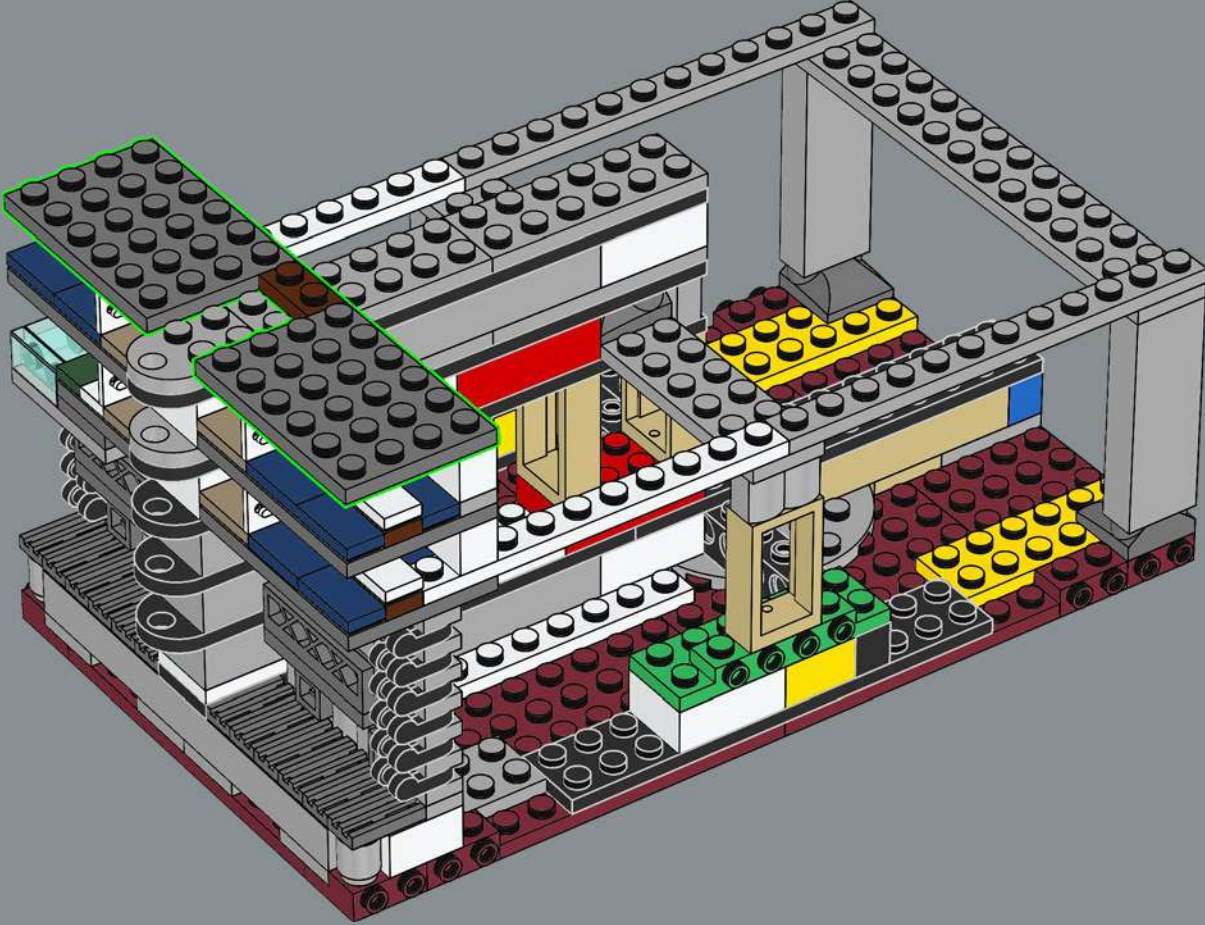

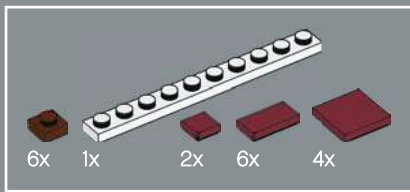

44

The ship was equipped with her own waterworks, capable of heating and pumping water to all parts of the vessel.

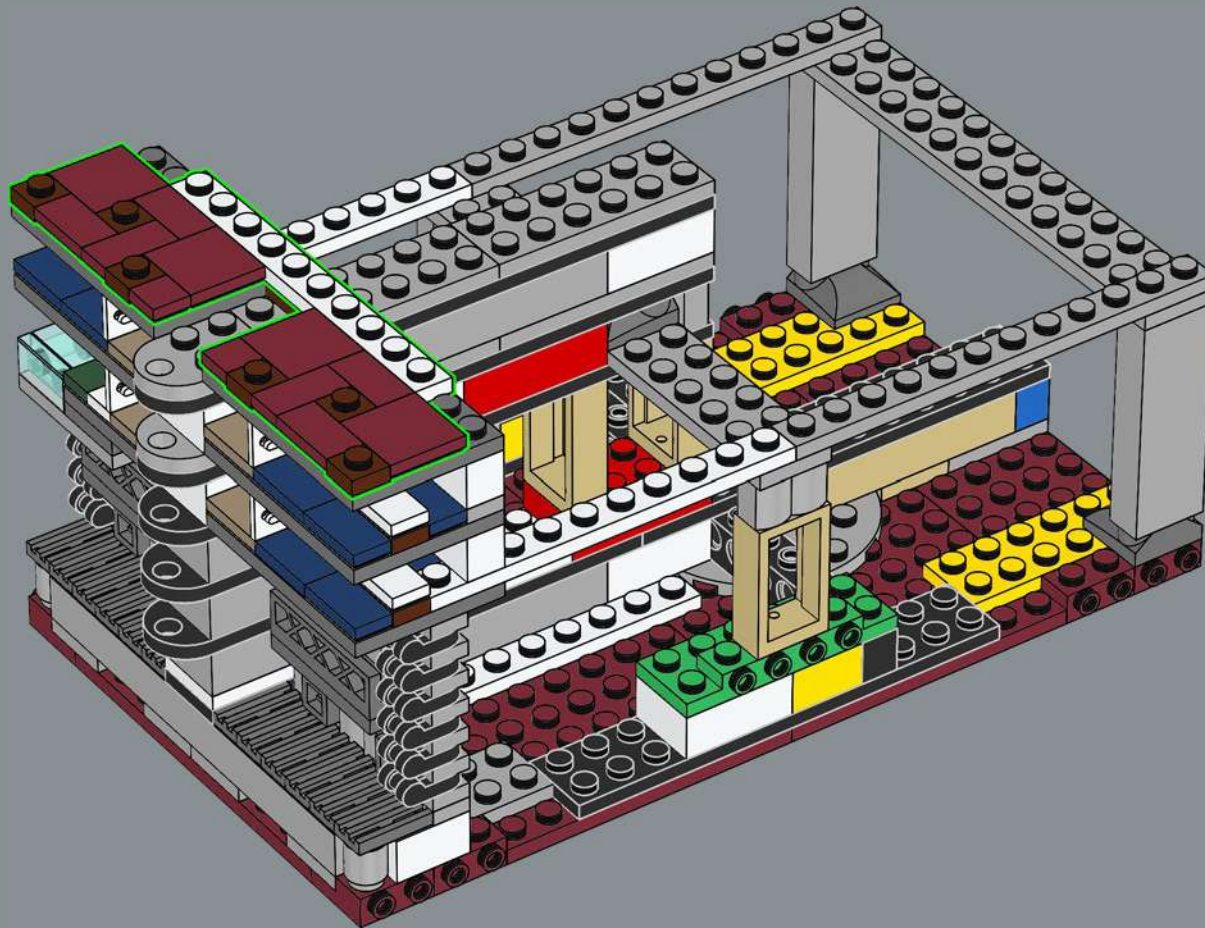

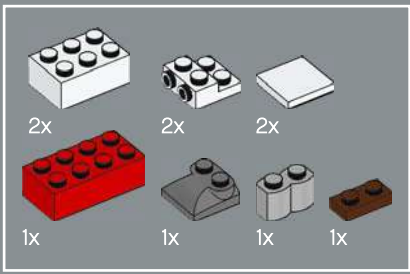

45

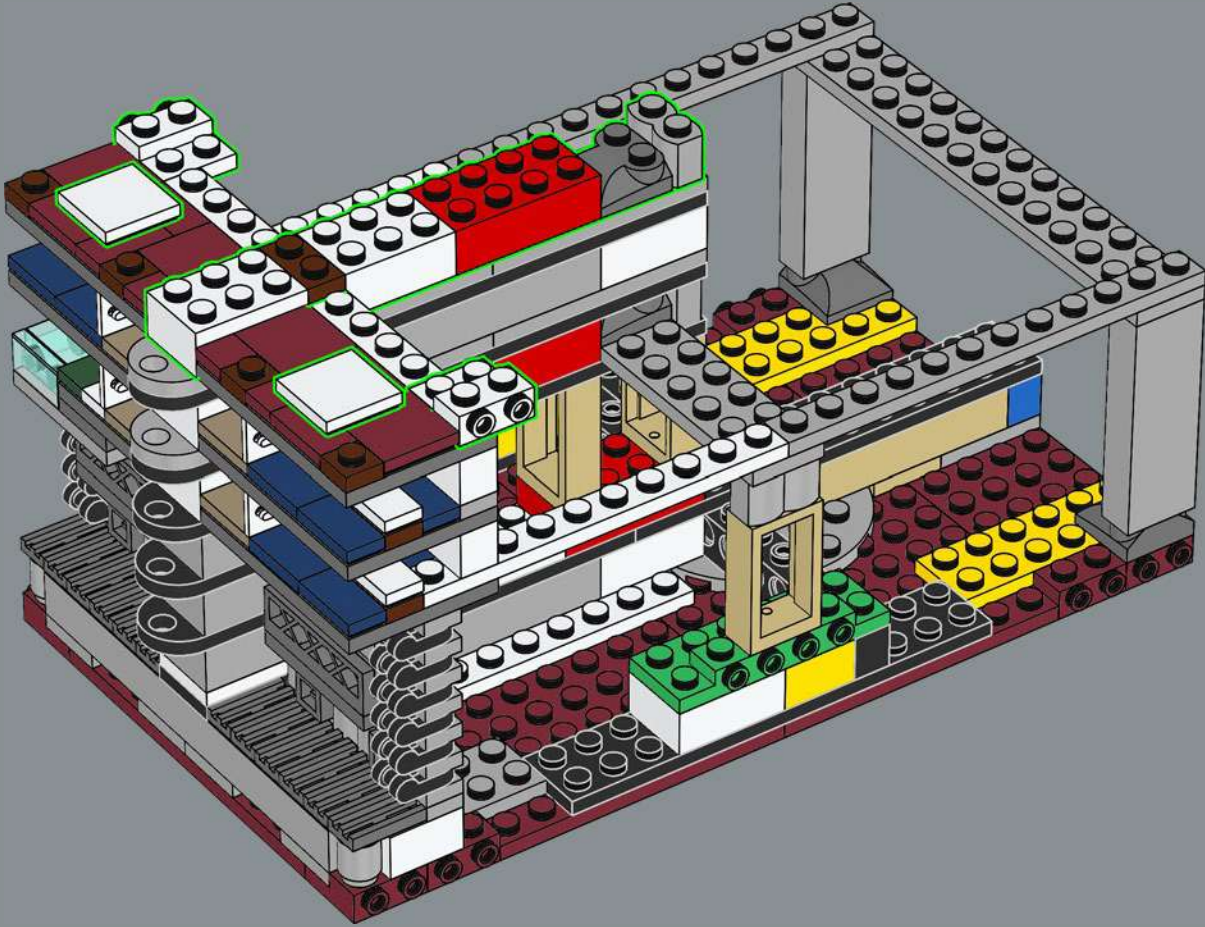

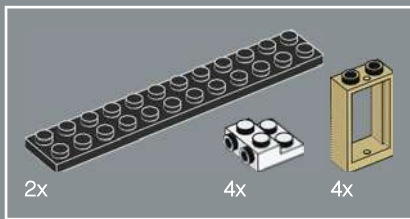

46

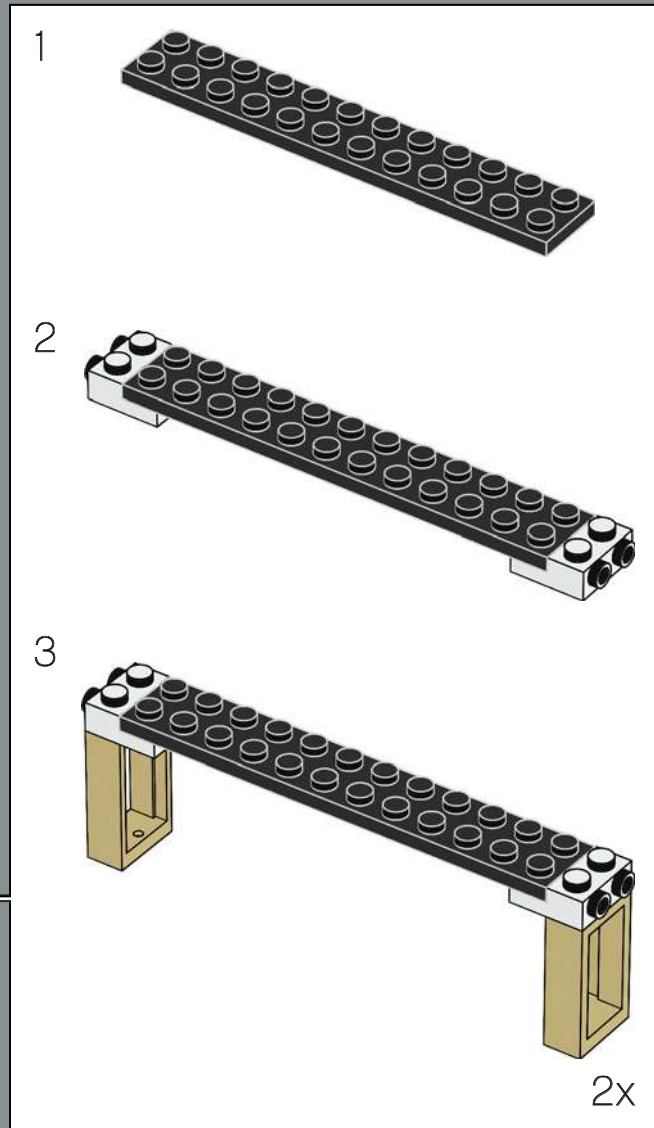
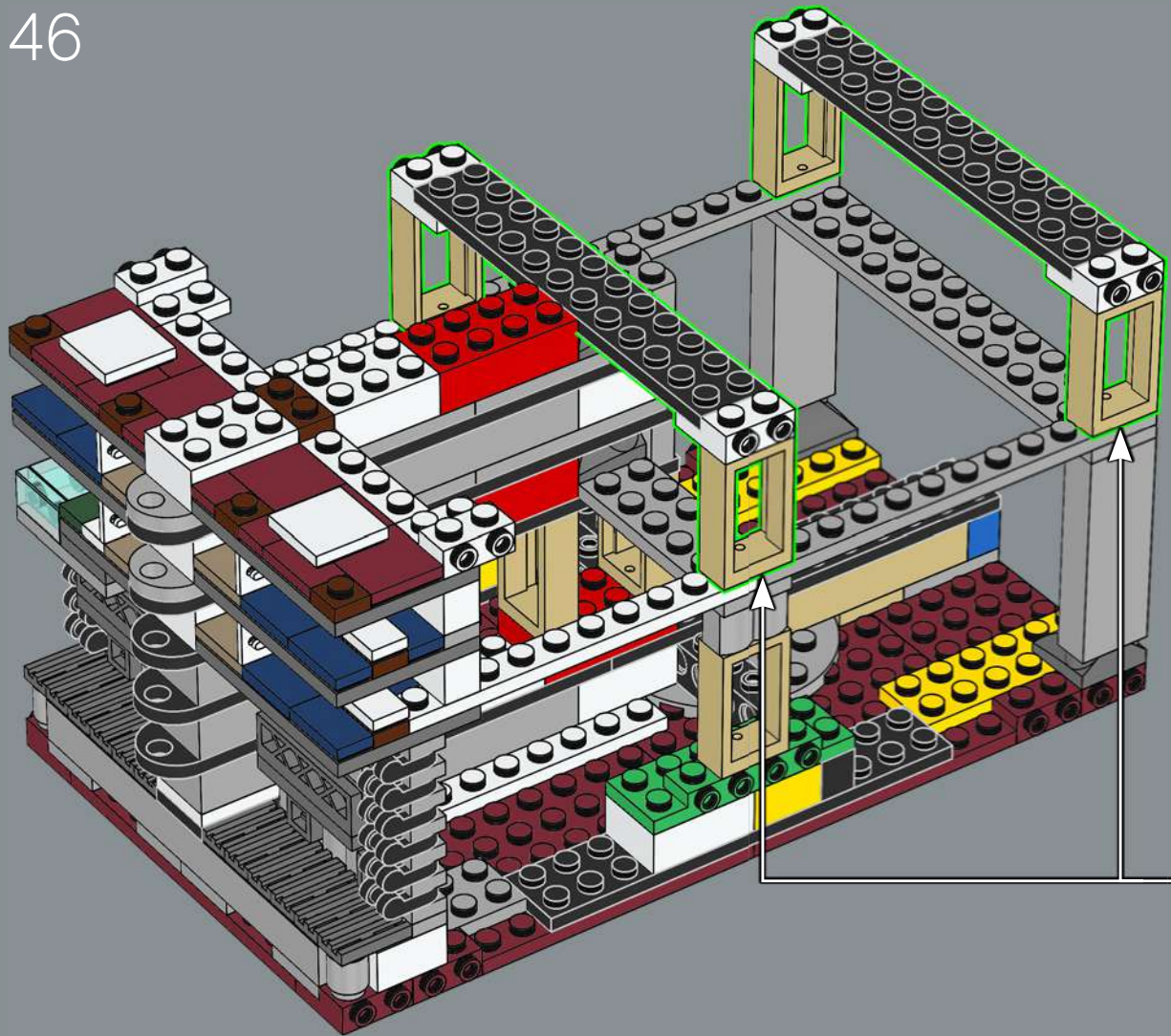

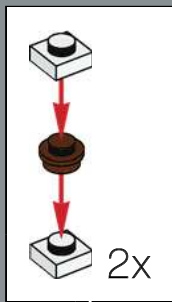
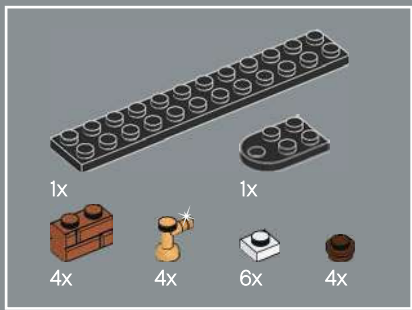

47

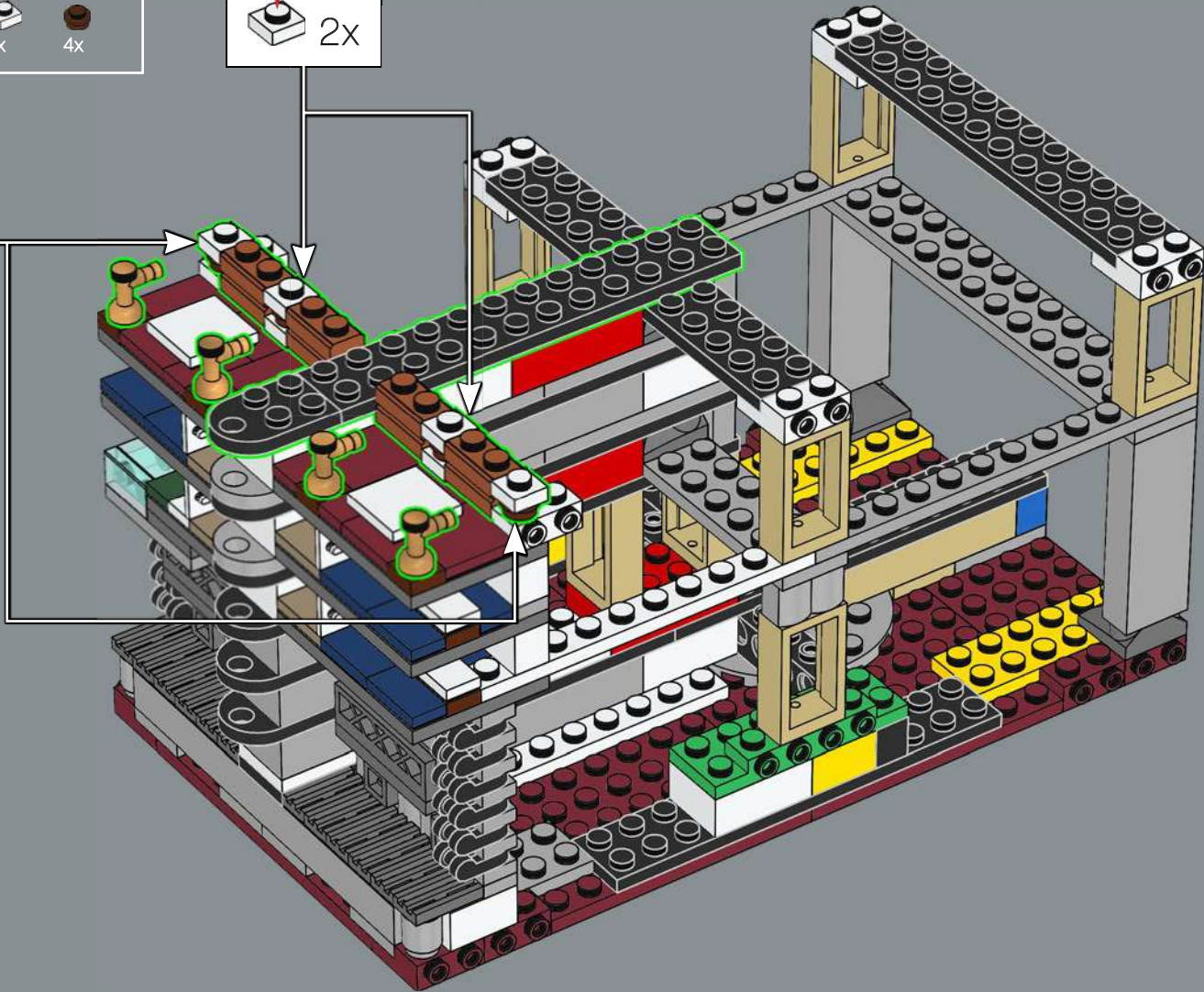
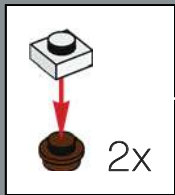

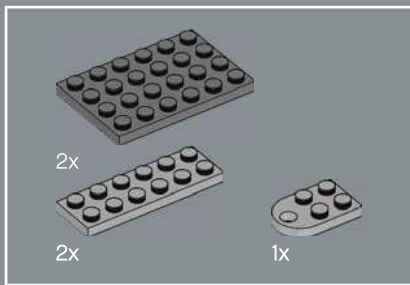

48

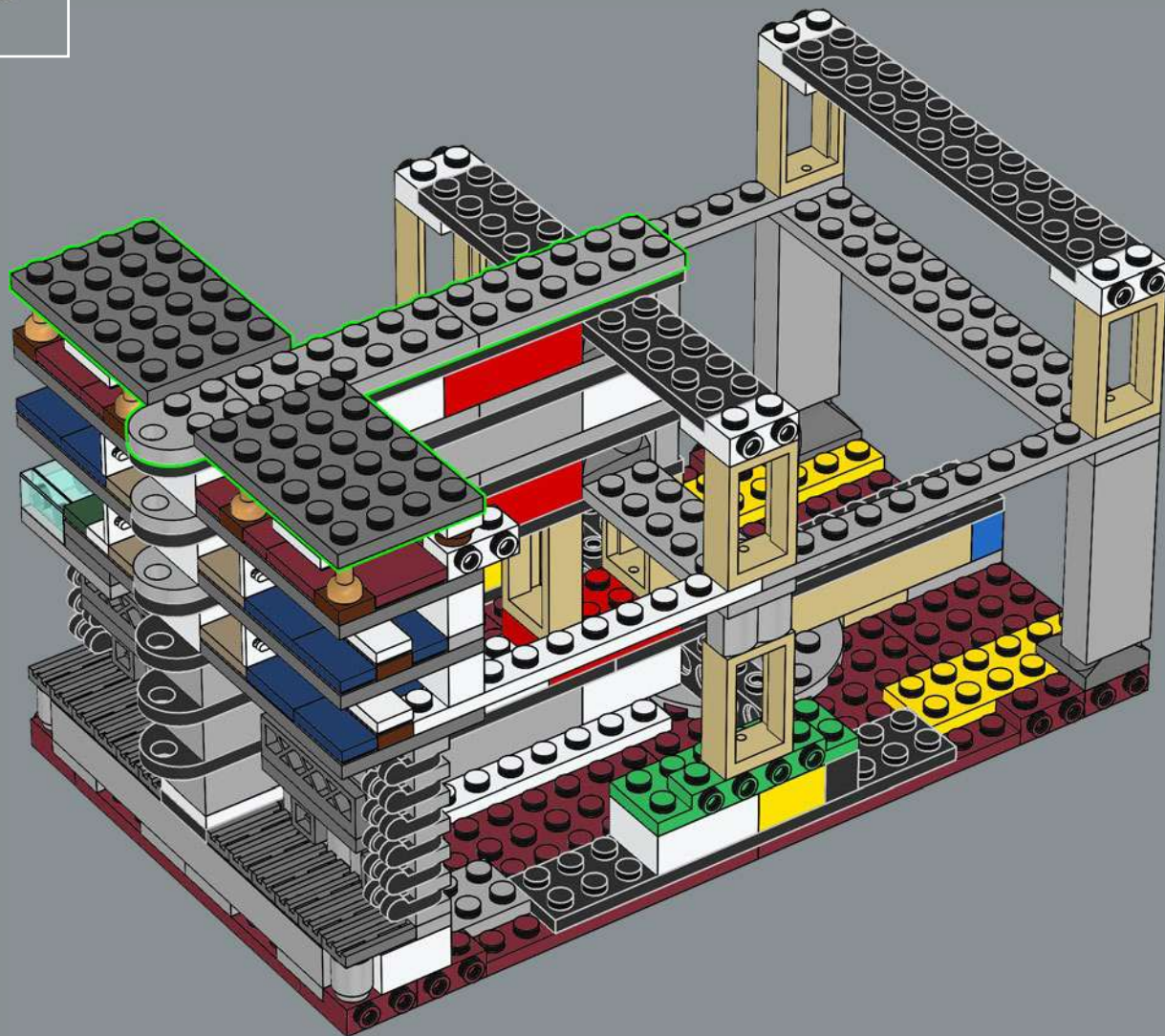



49

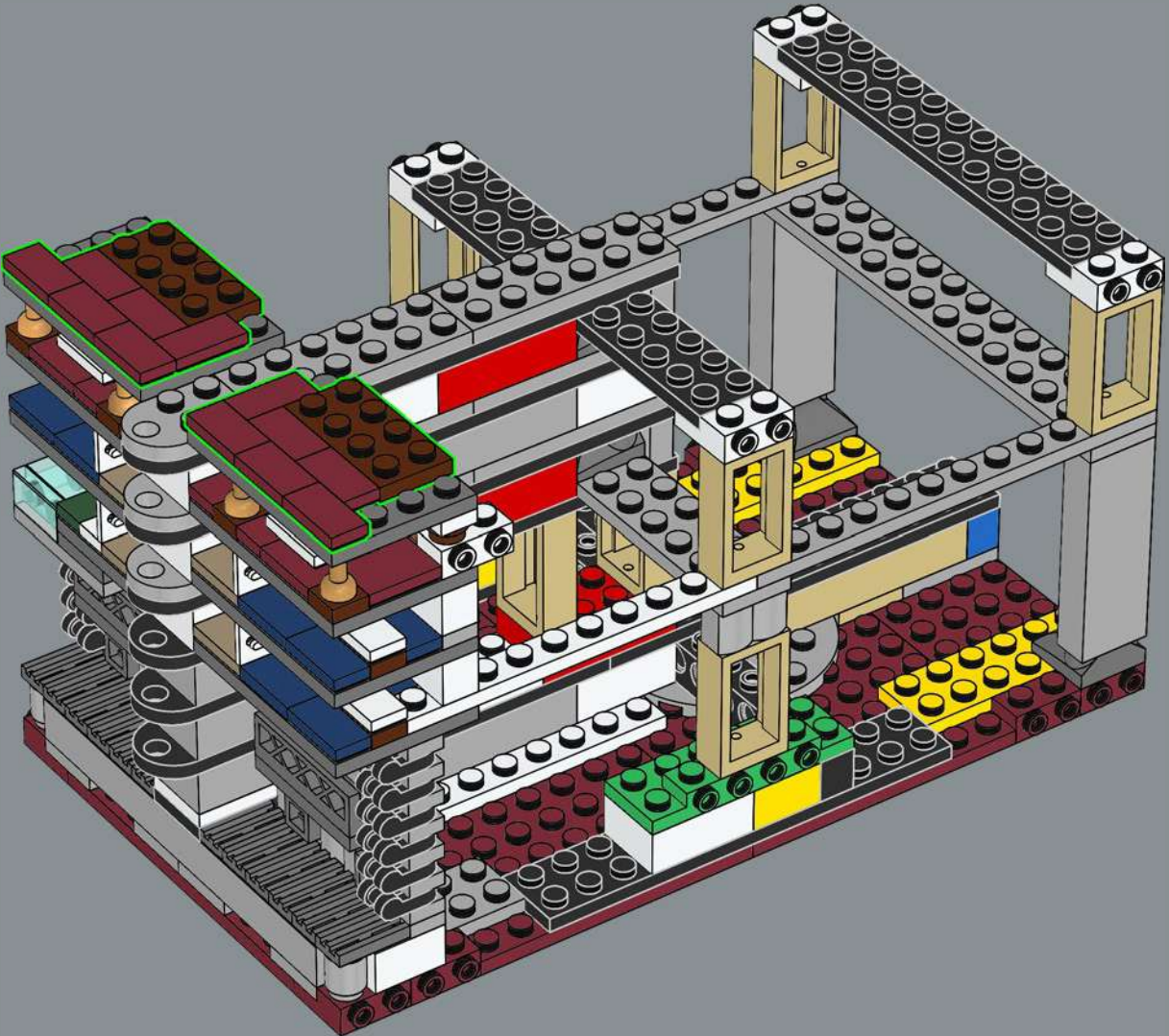

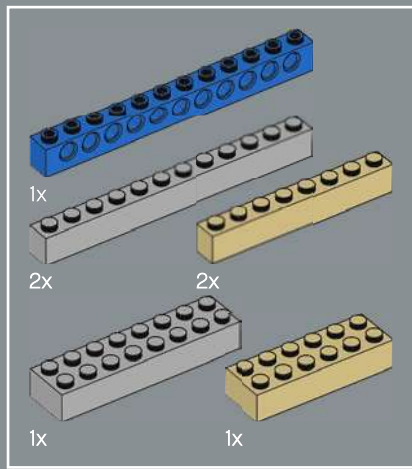

50

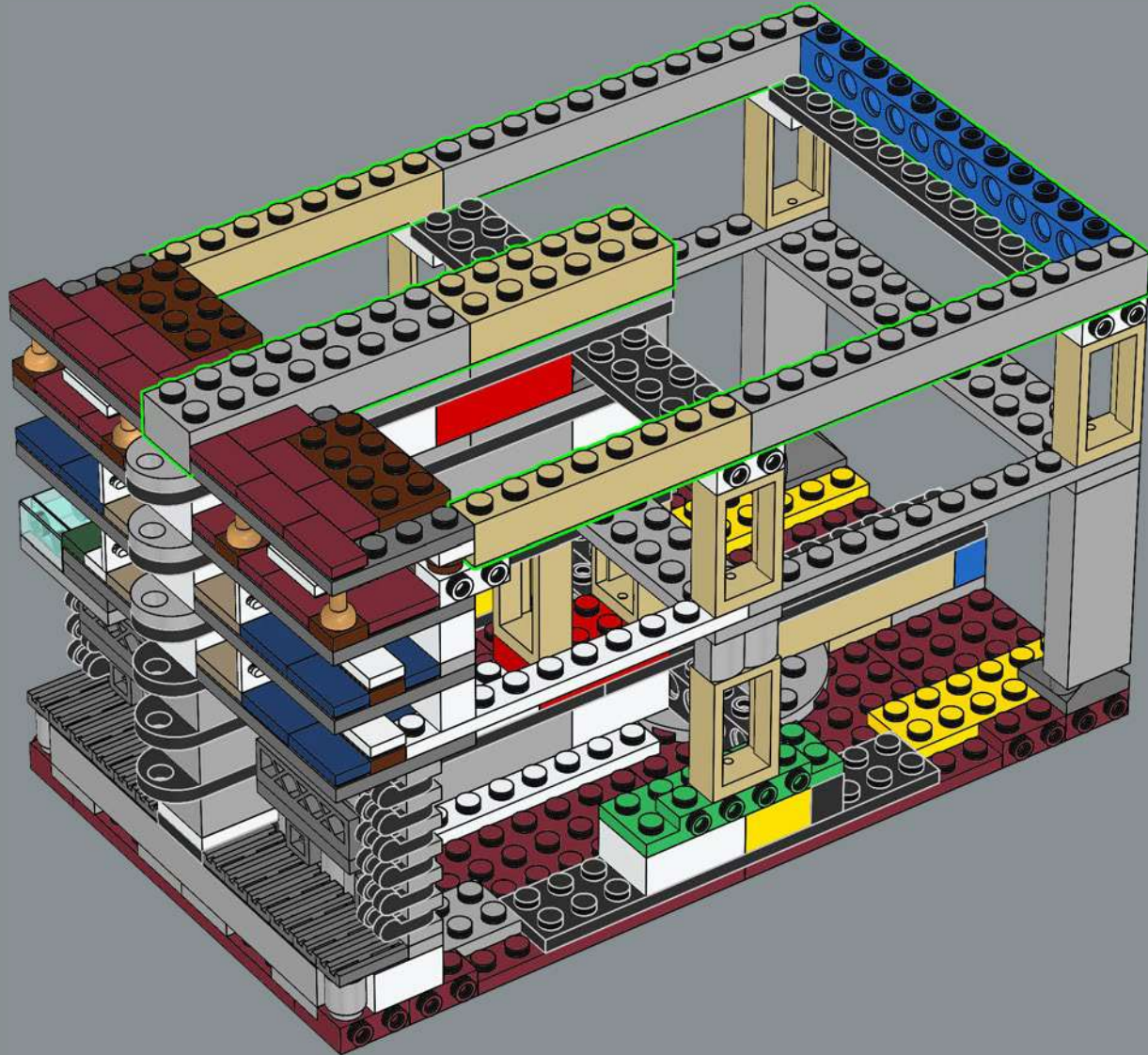

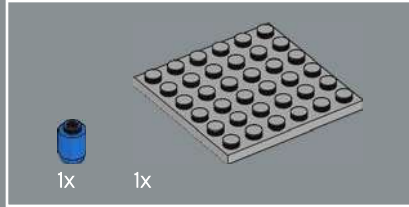
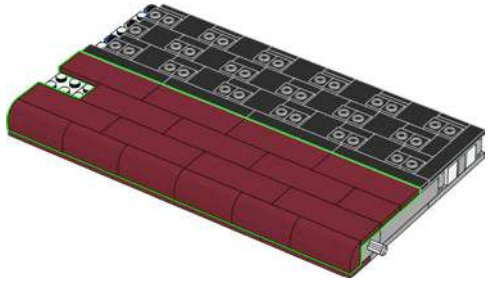
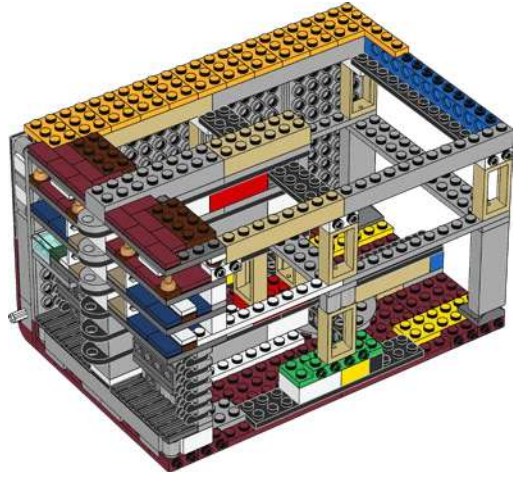
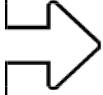

51

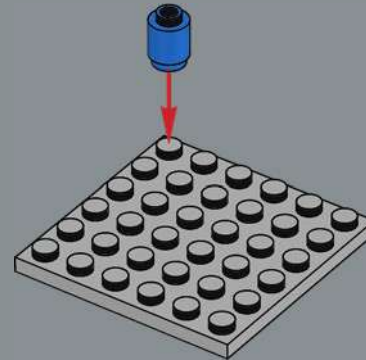

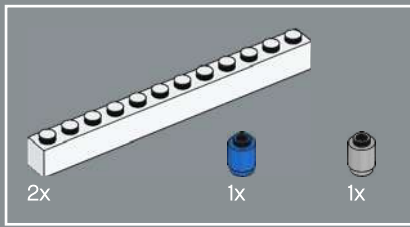

52

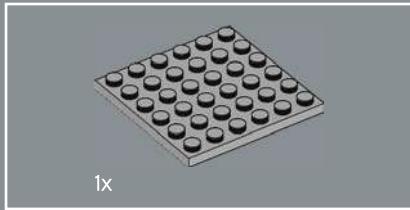
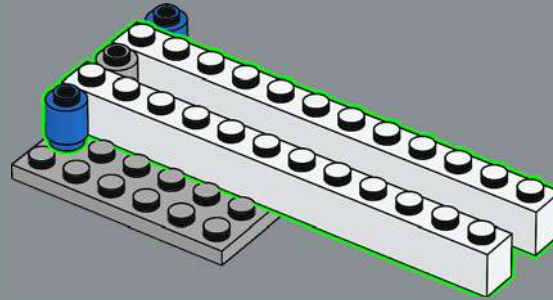

53

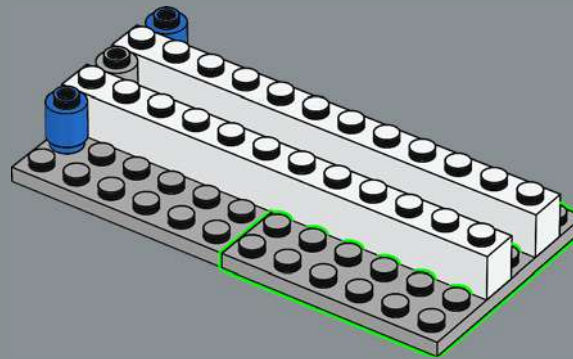

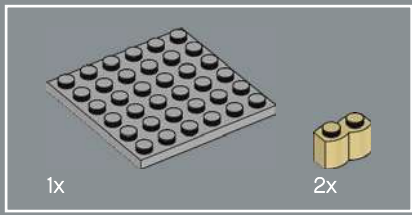

54

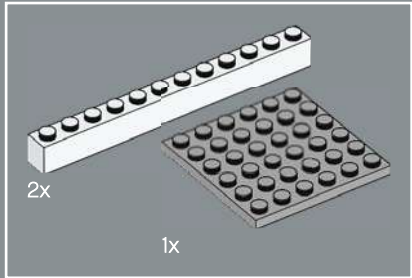
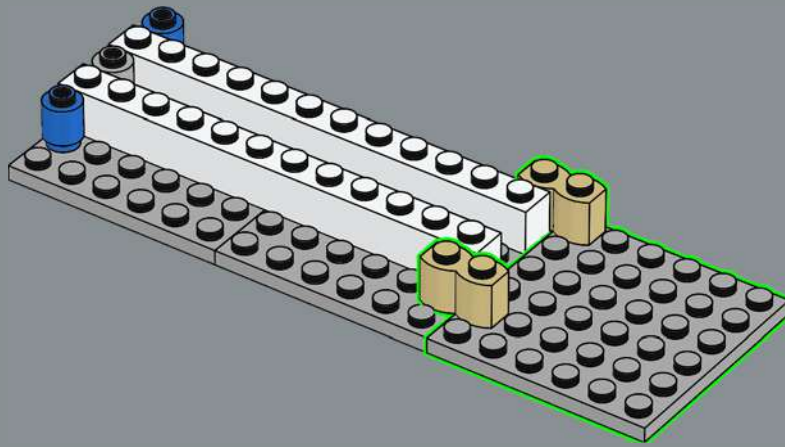

55

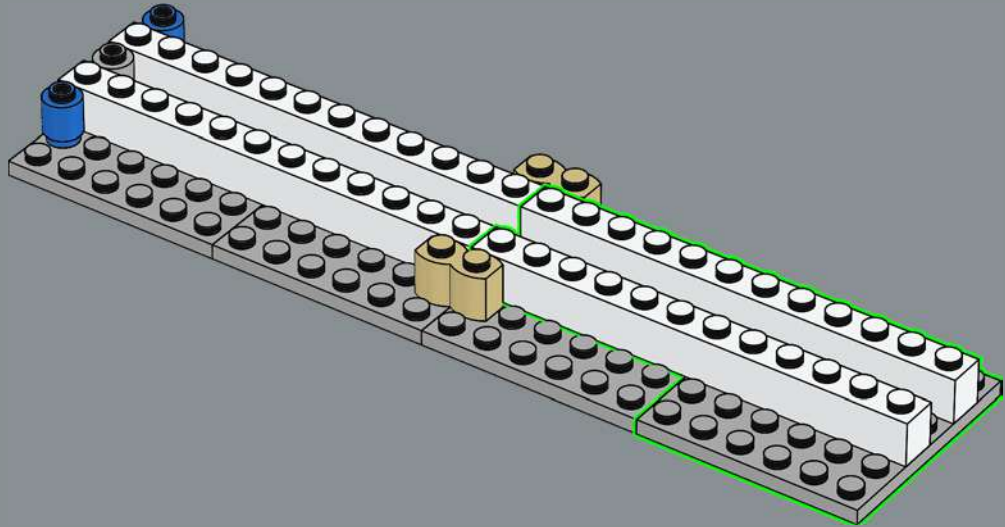

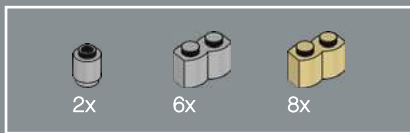

56

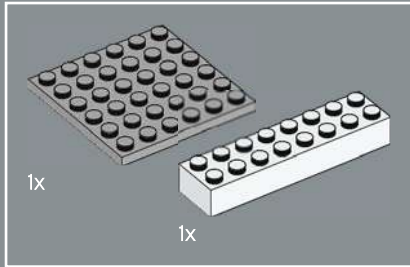
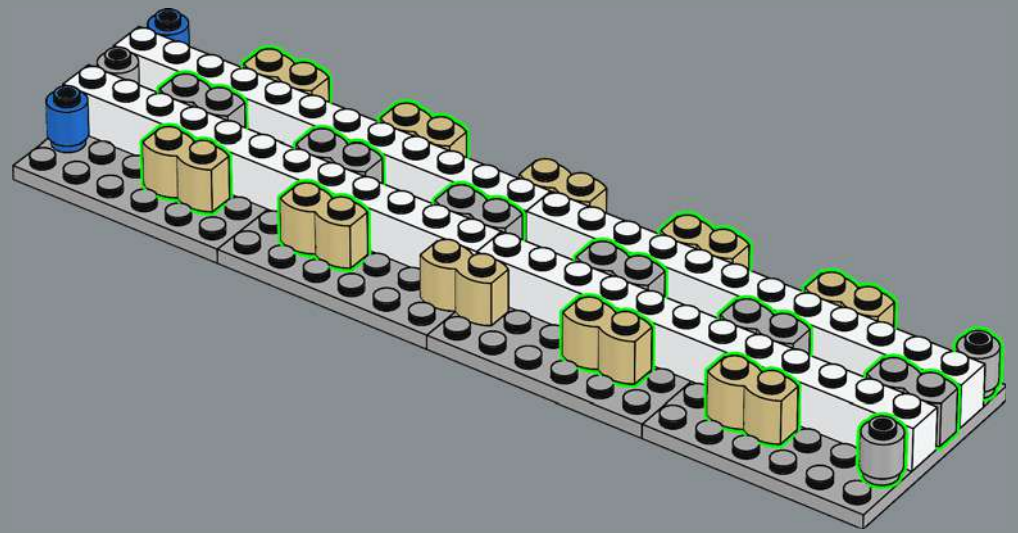

57

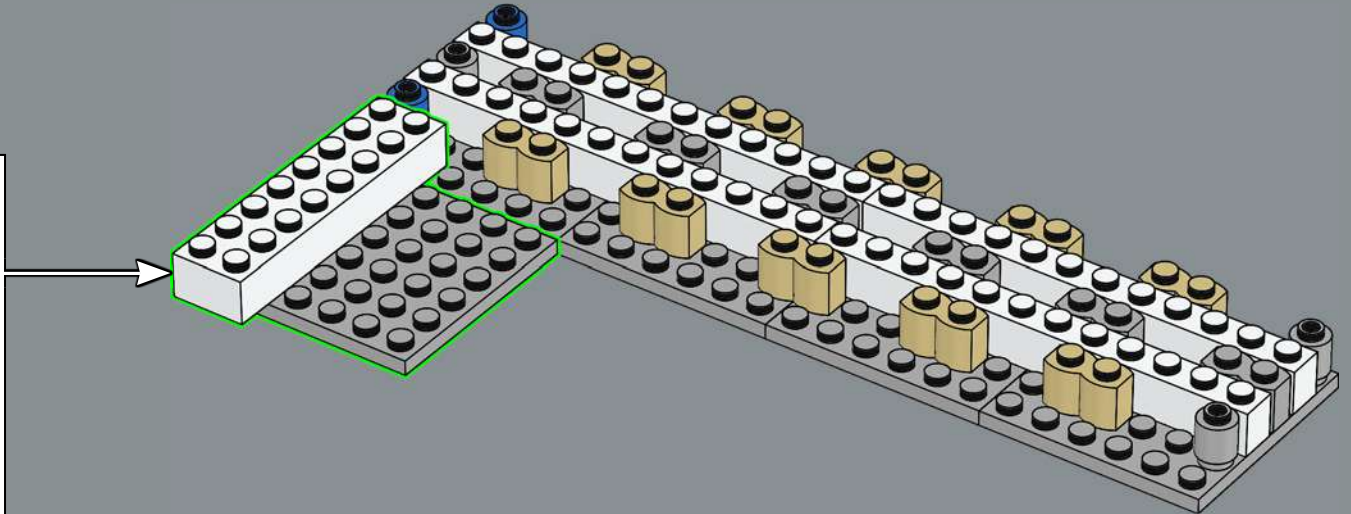
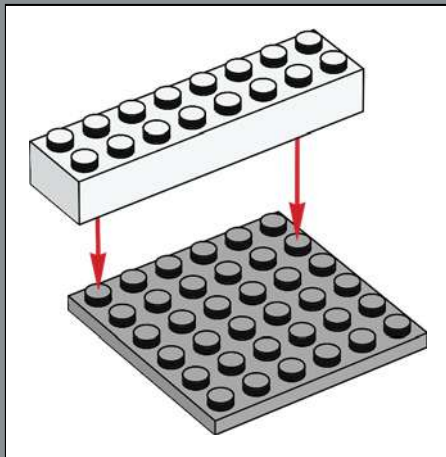

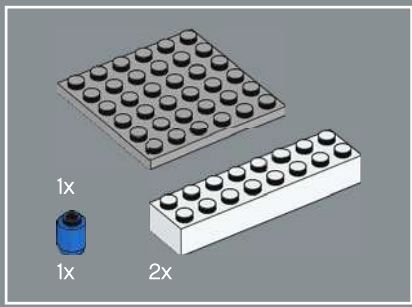

58

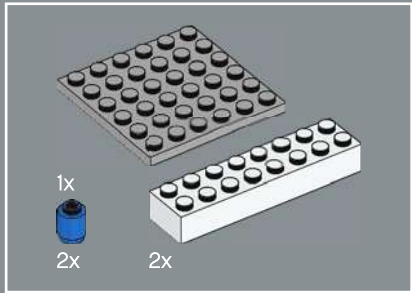
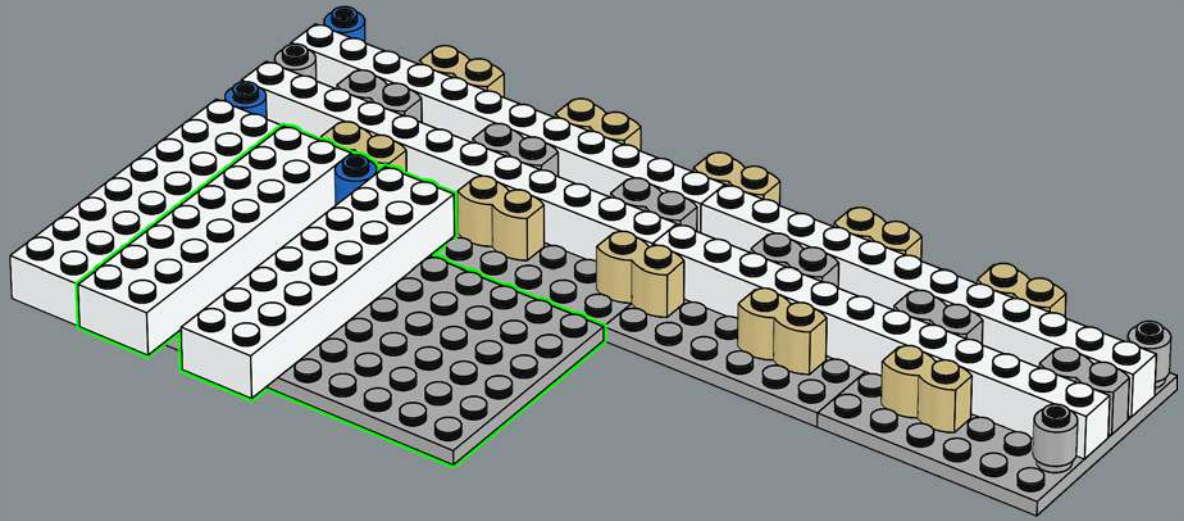

59

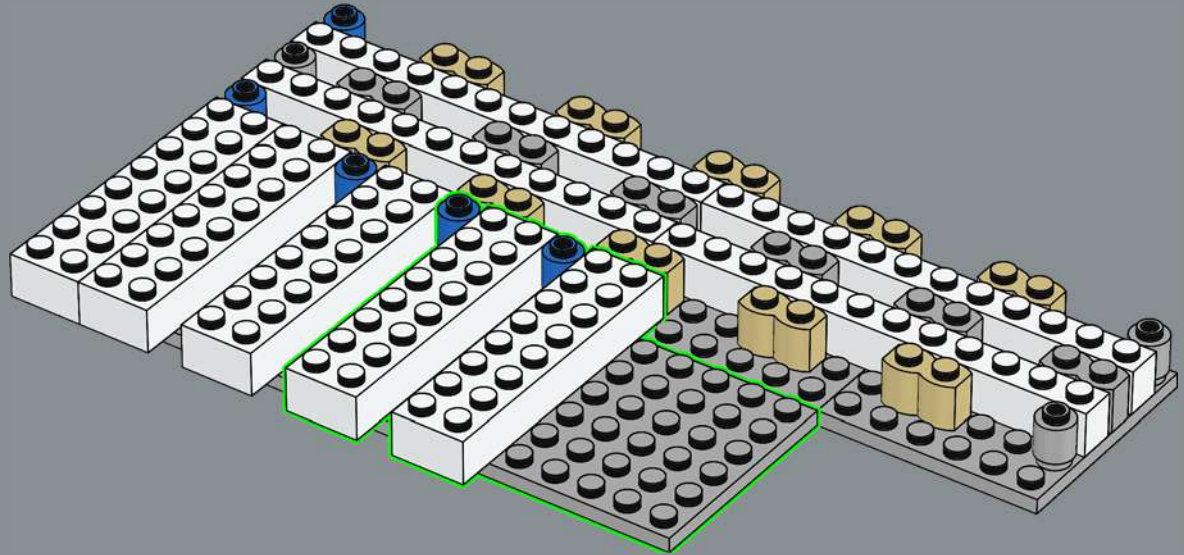

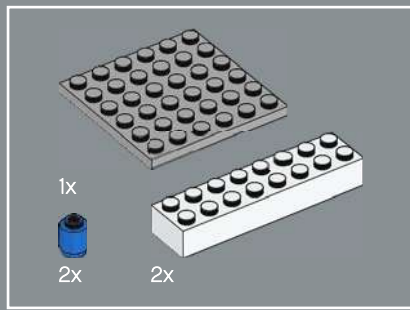

60

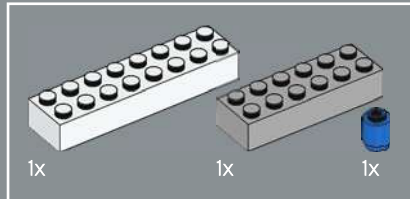
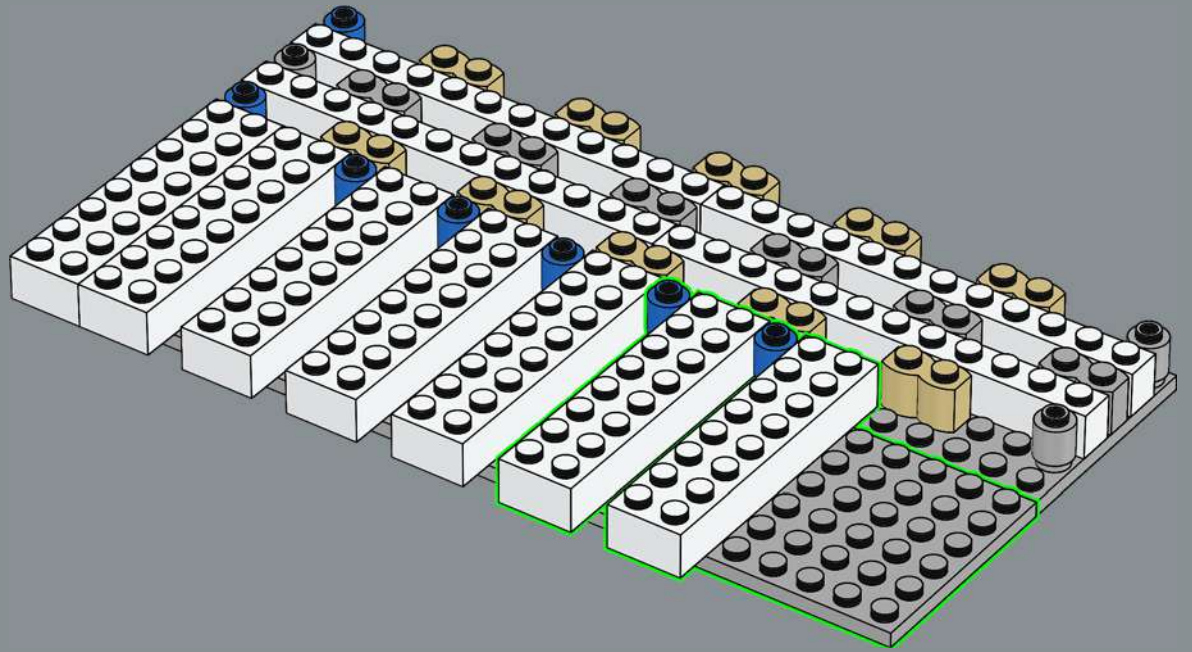

61

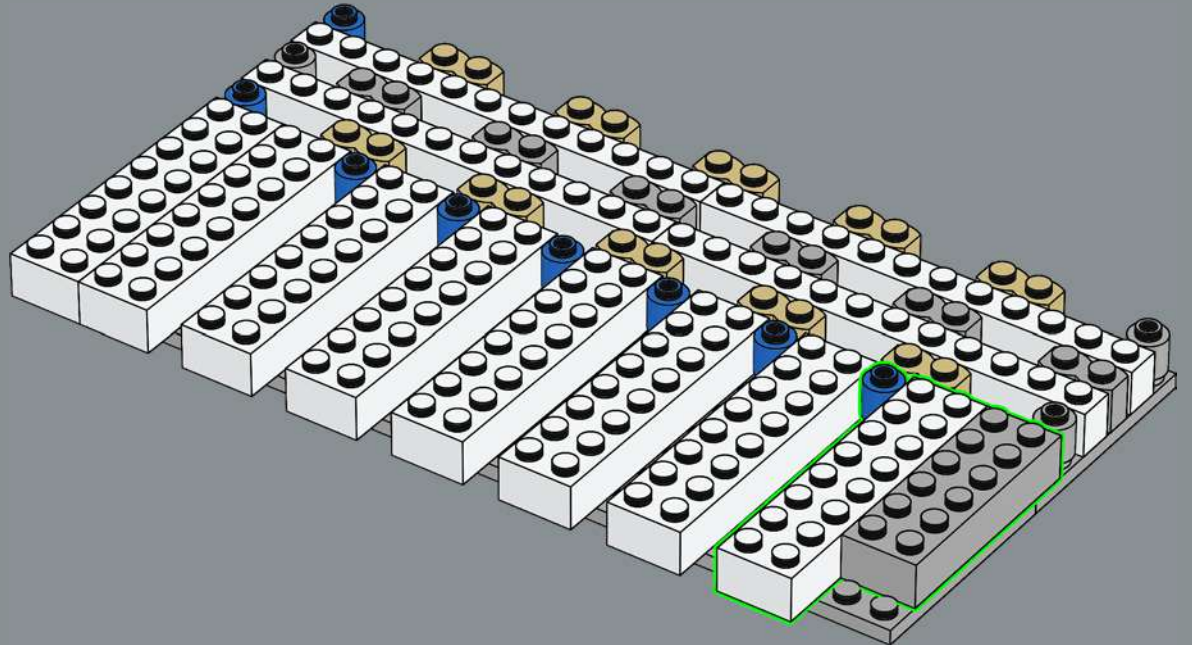

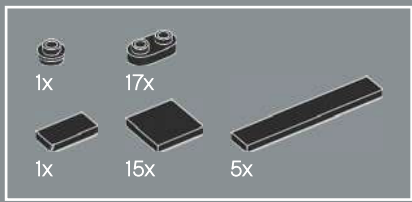

62

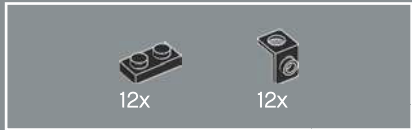
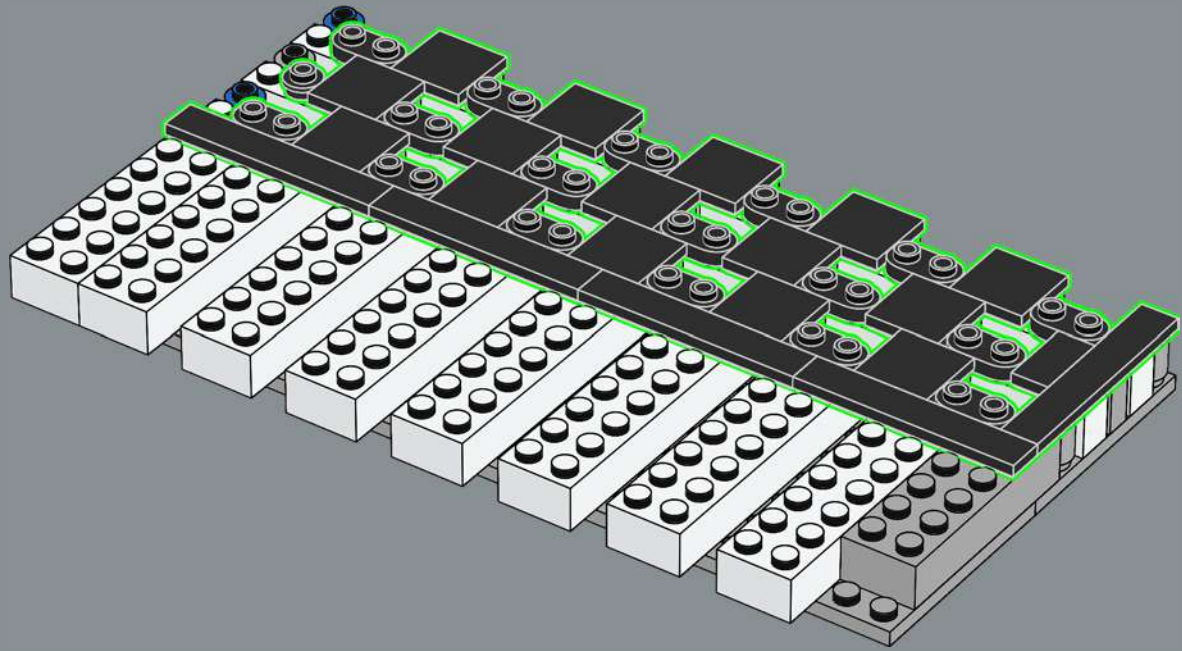

63

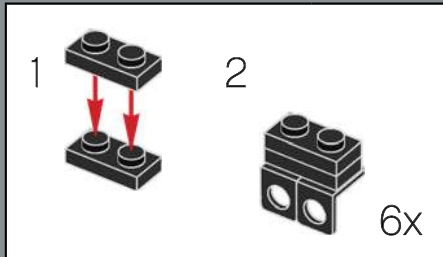
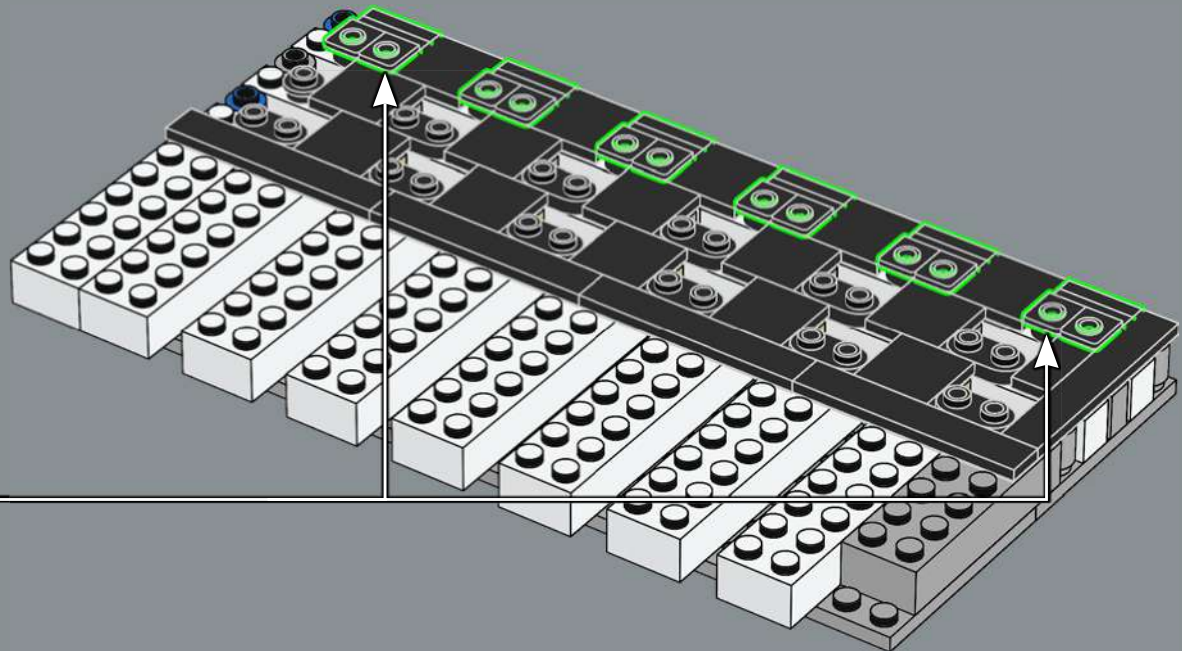



64

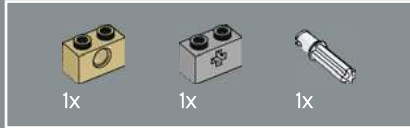
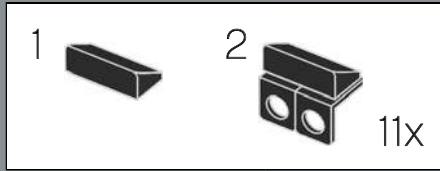
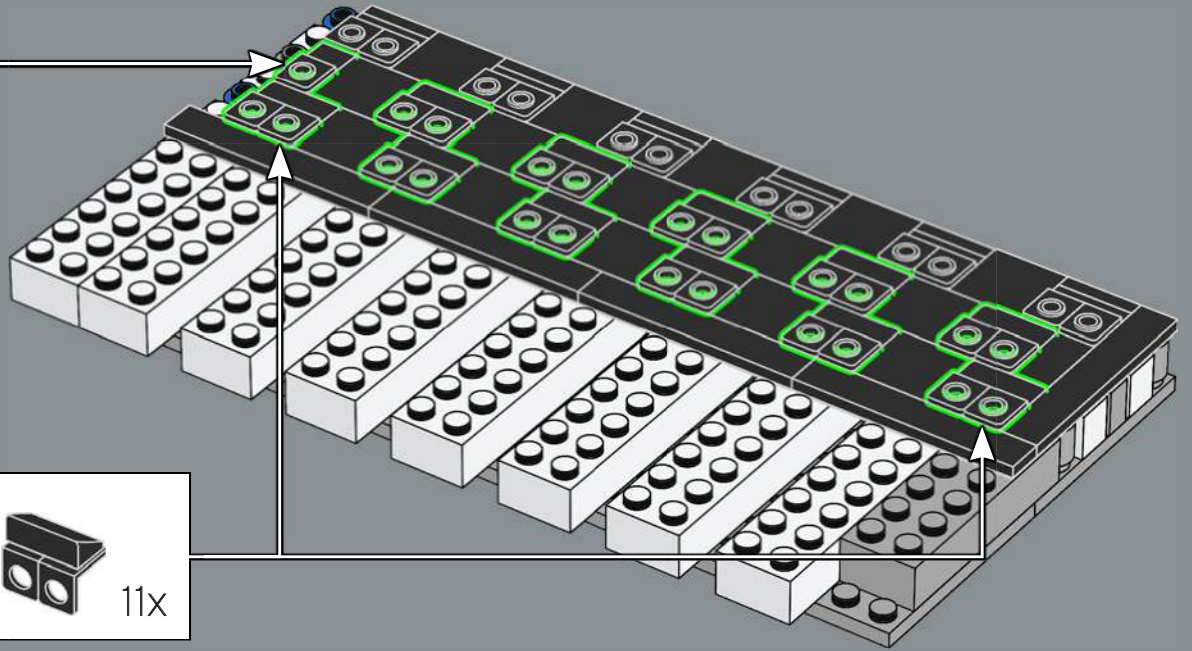

65

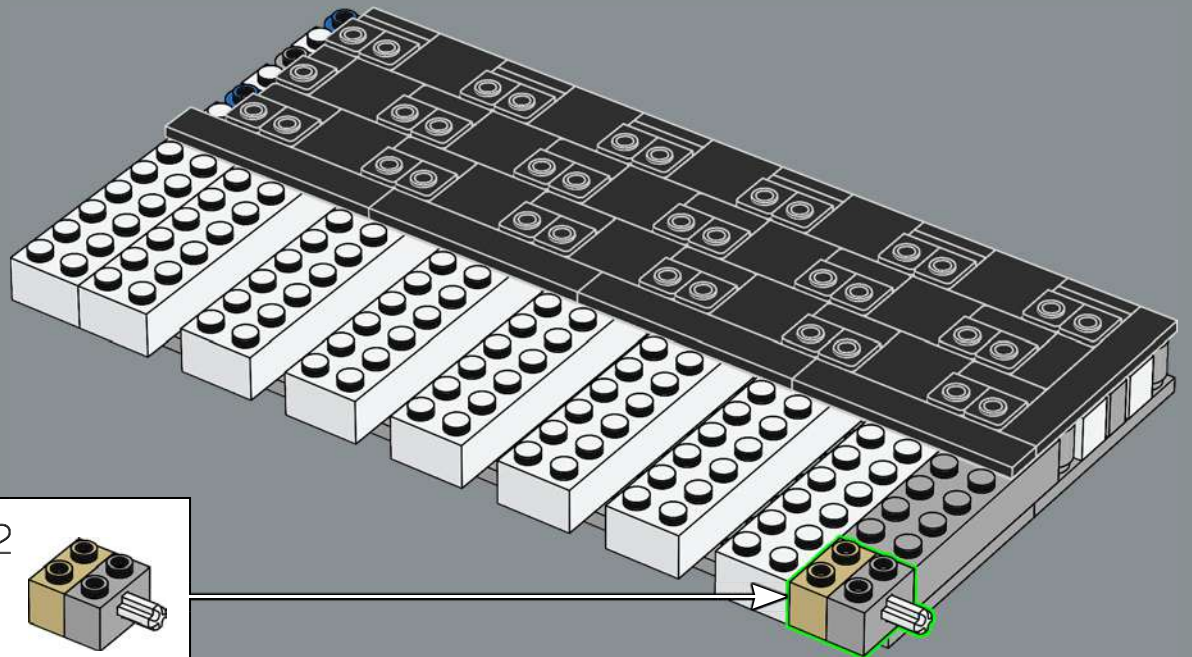
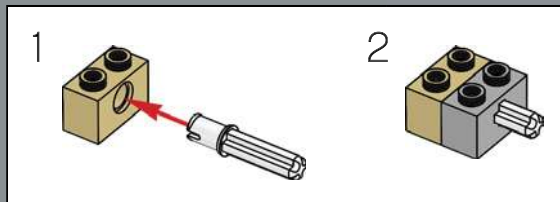

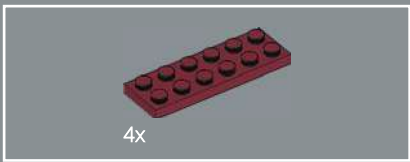

66

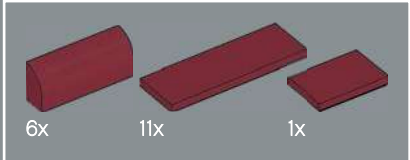
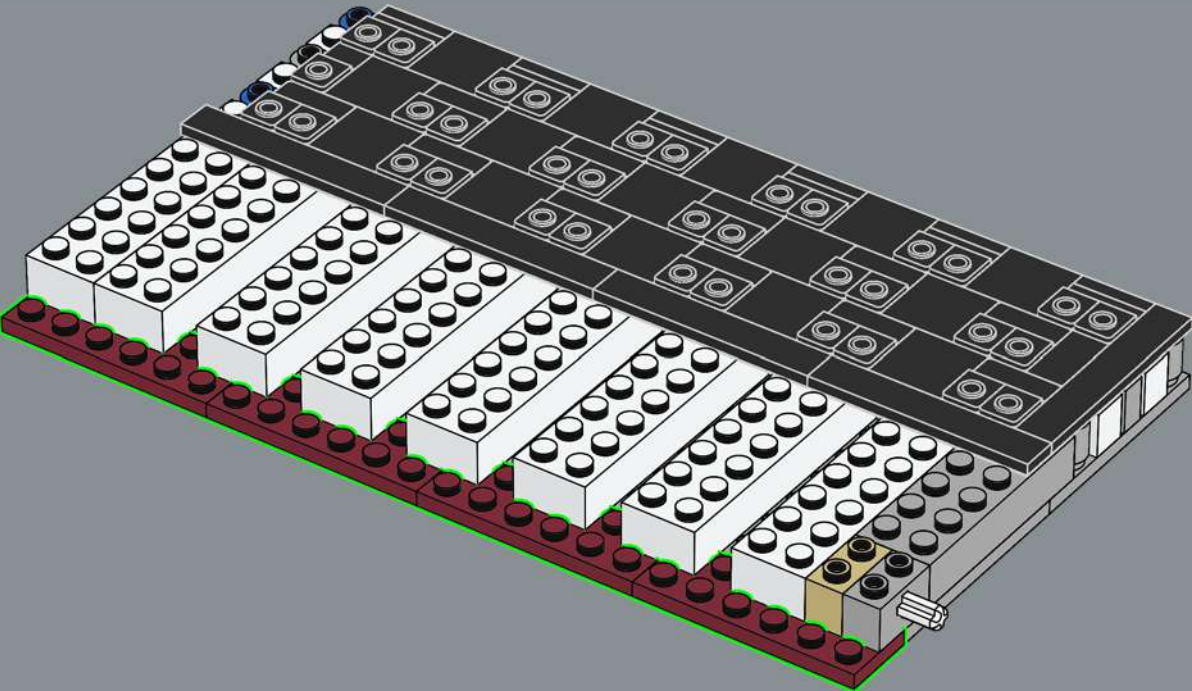

67

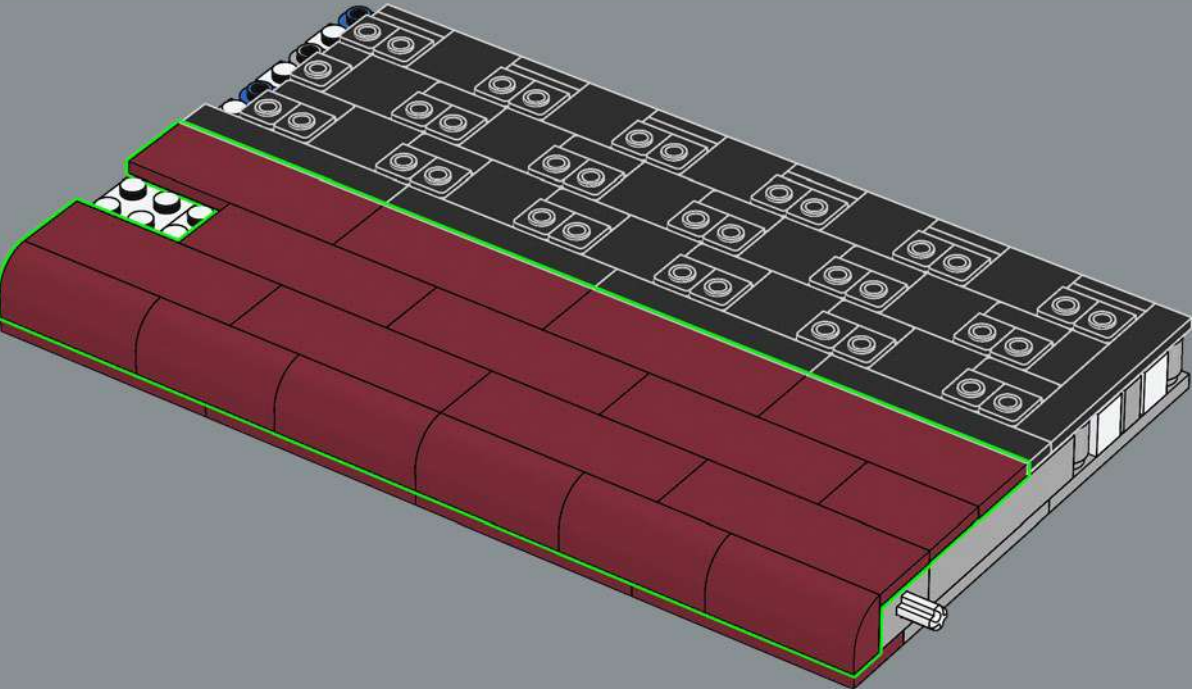

68

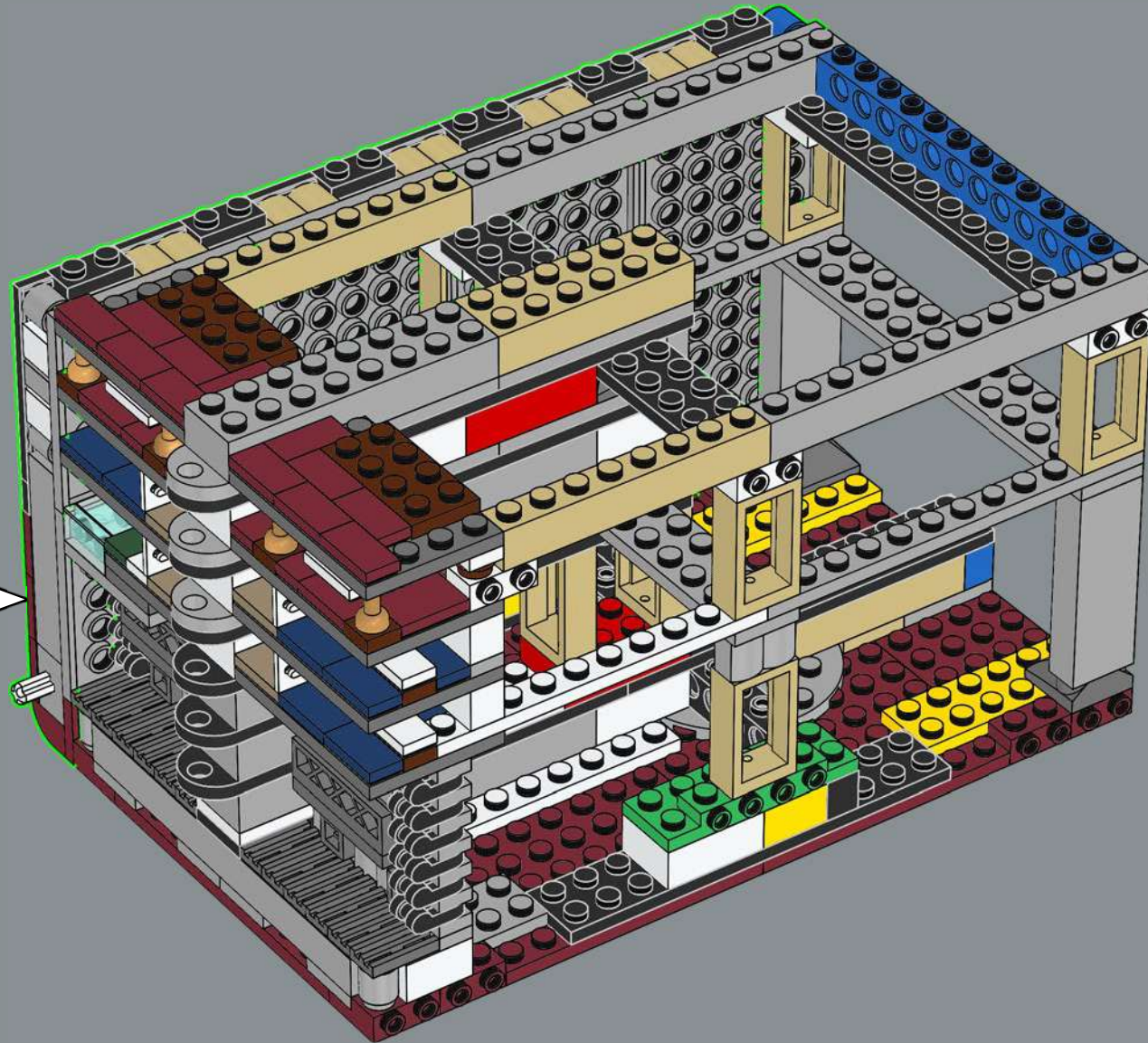

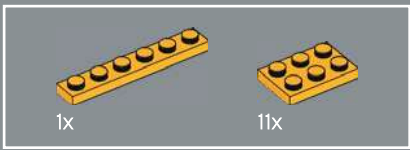

69

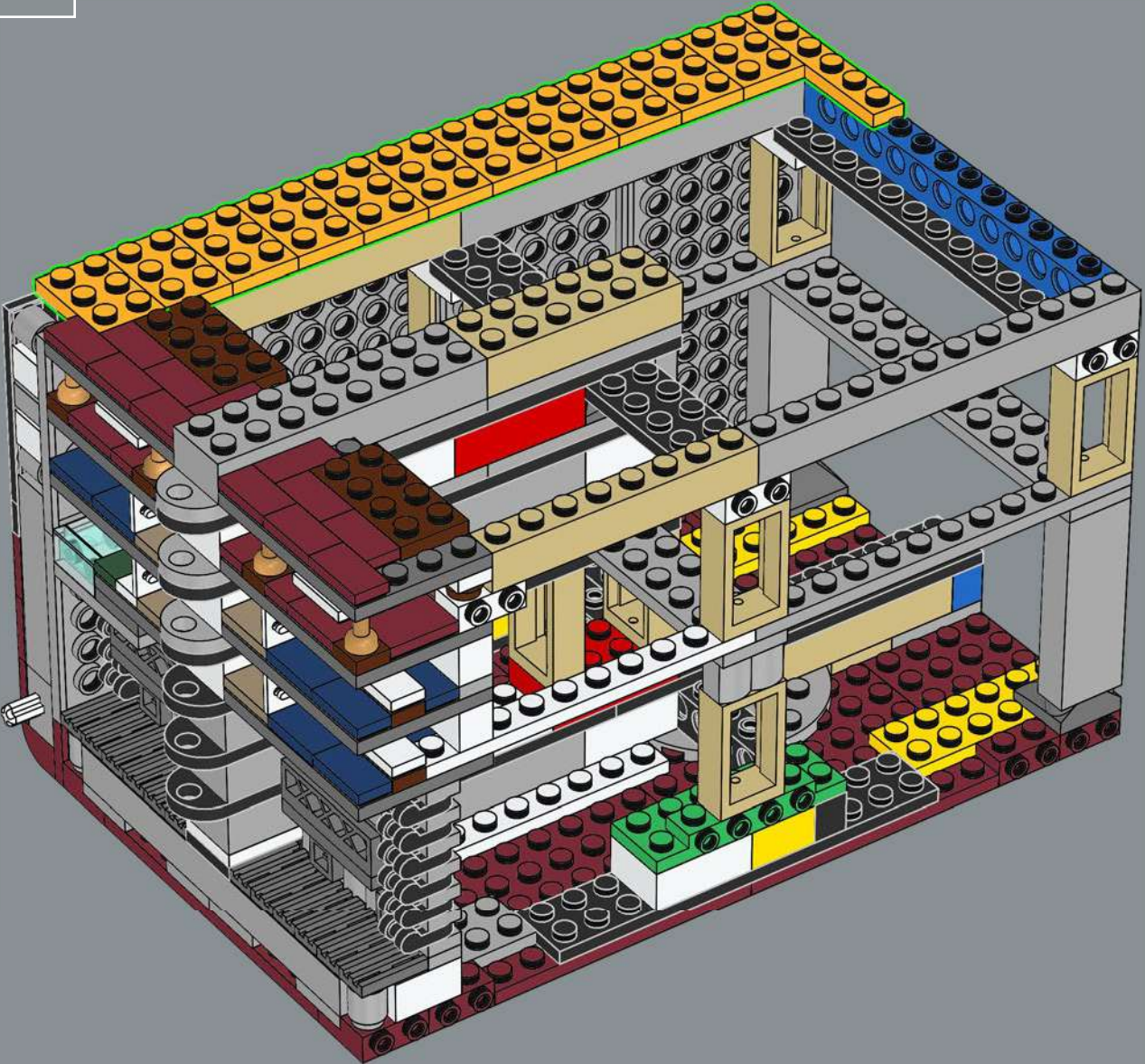

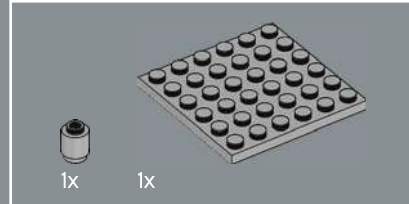
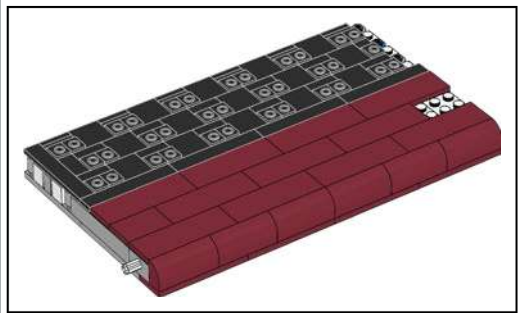
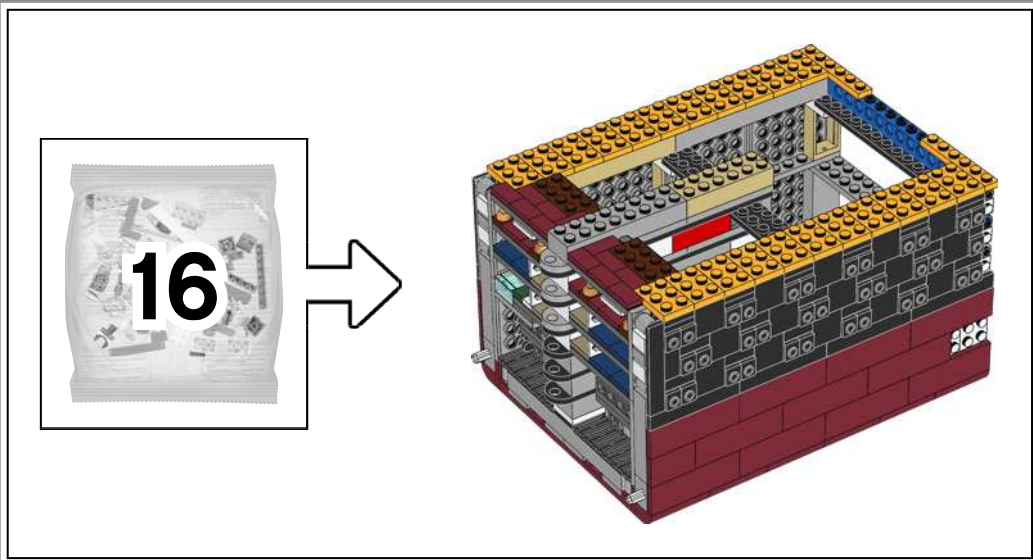

70

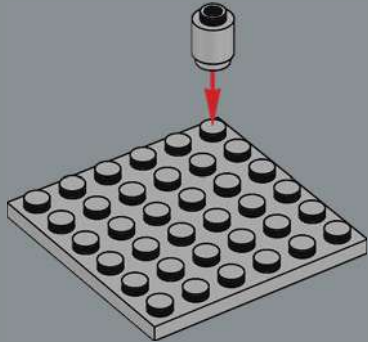

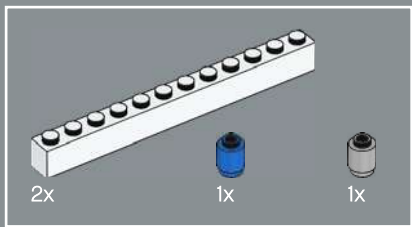

71

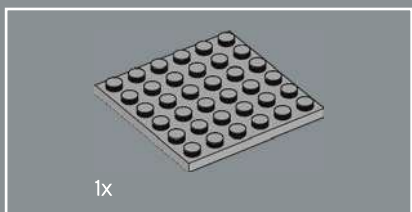
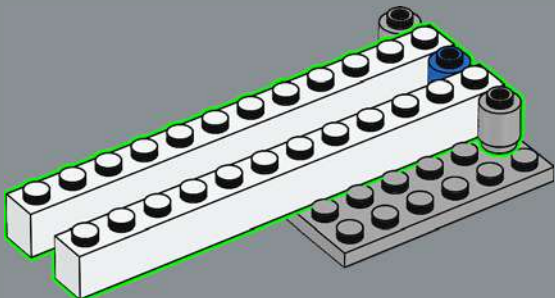

72

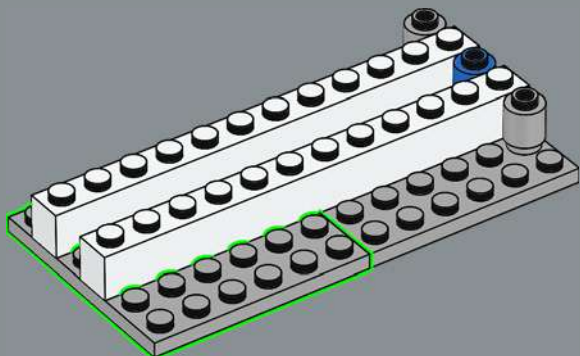

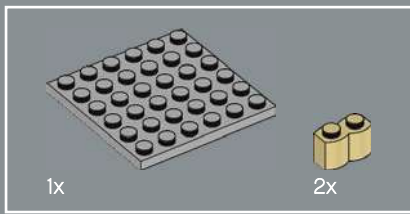

73

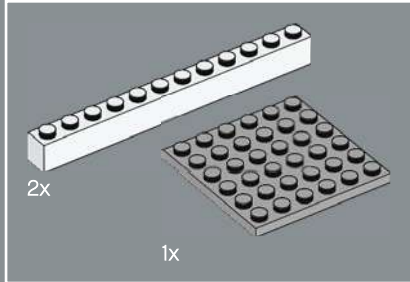
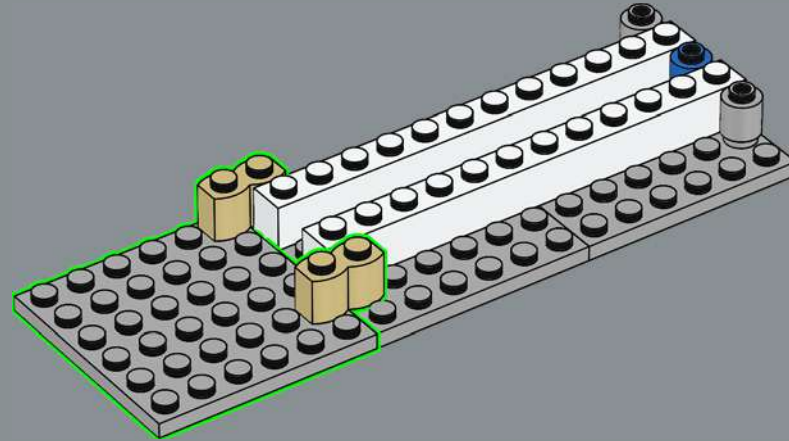

74

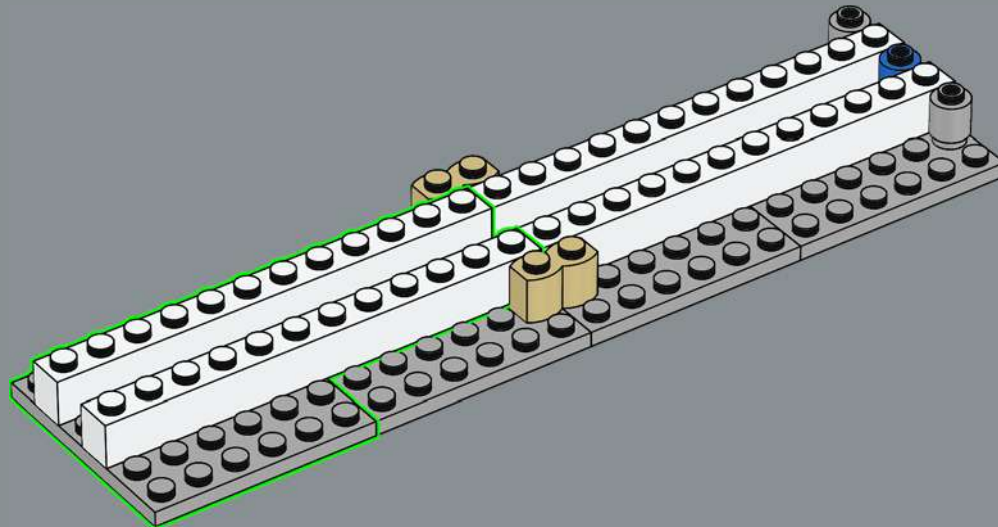

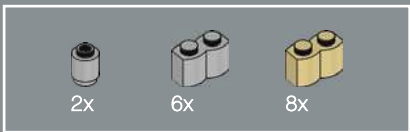

75

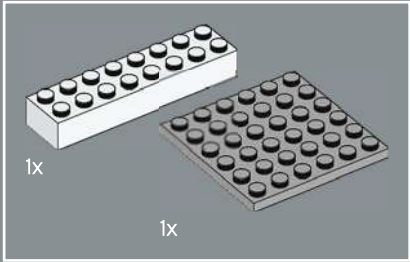
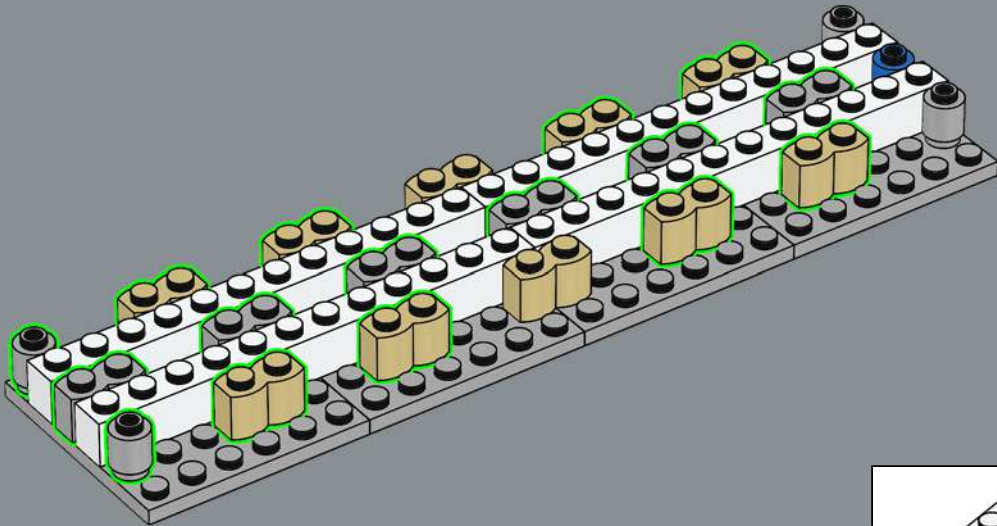

76

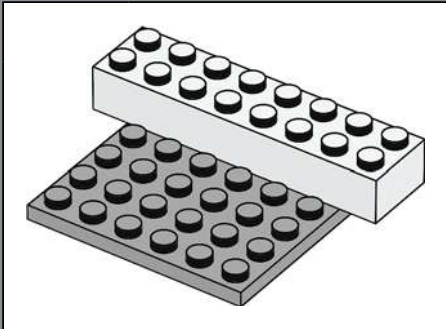
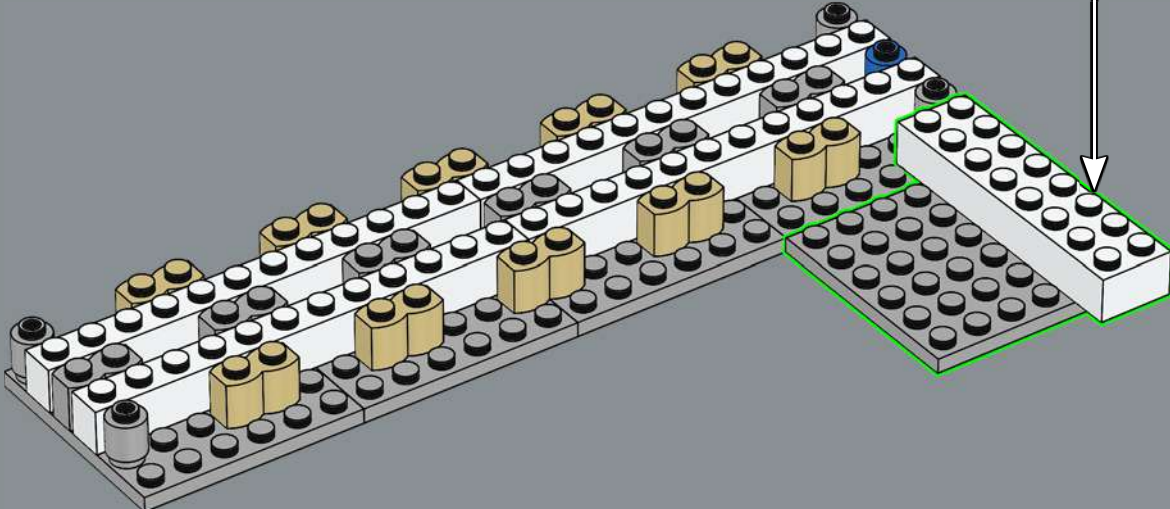

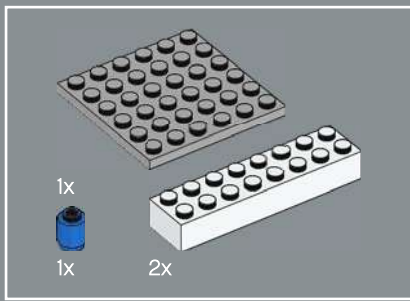

77

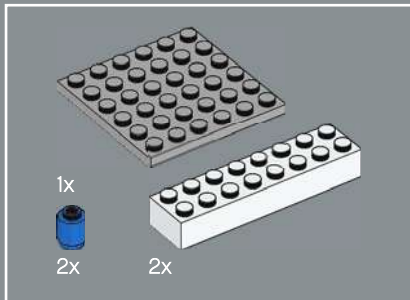
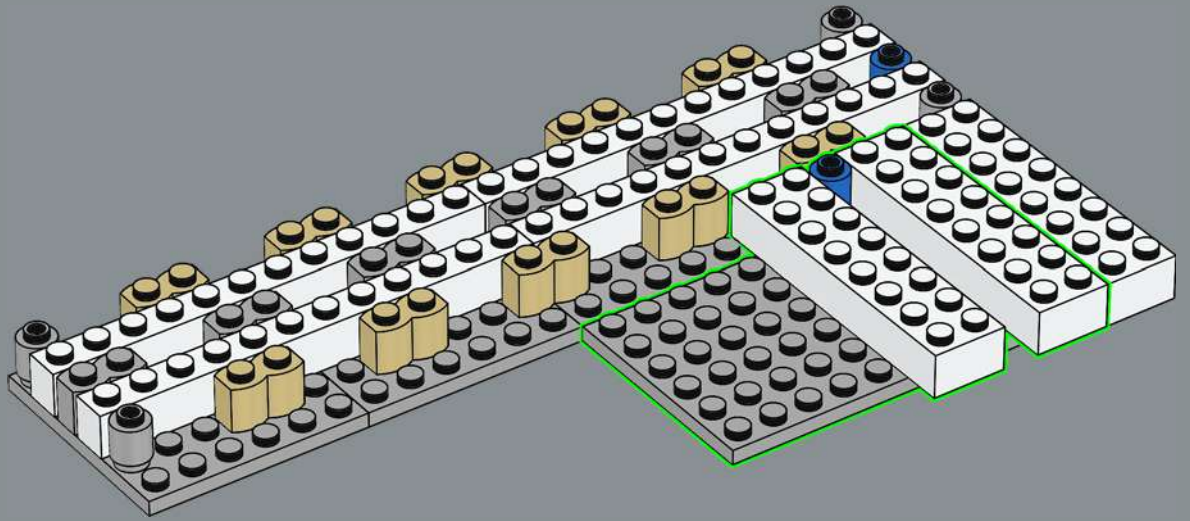

78

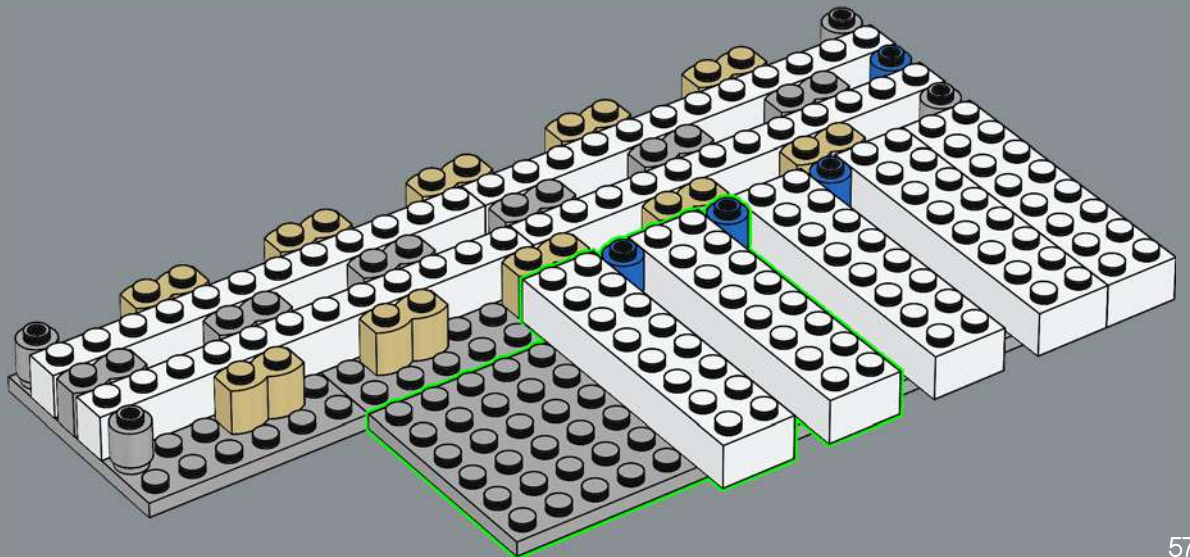

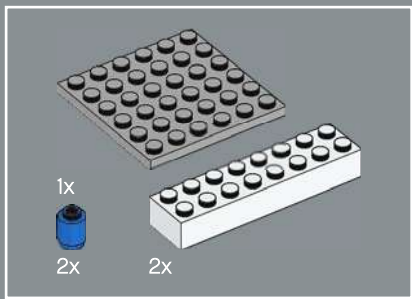

79

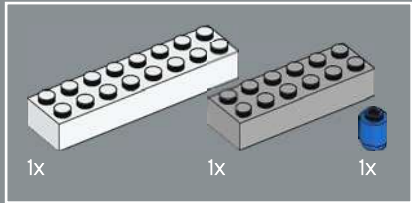
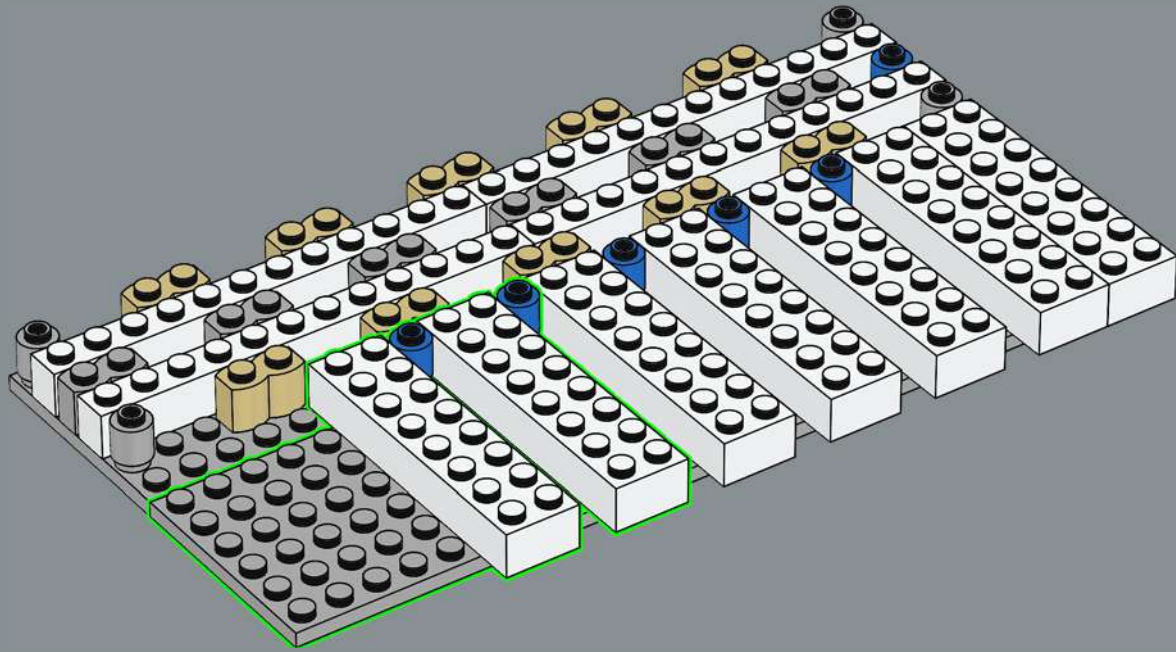

80

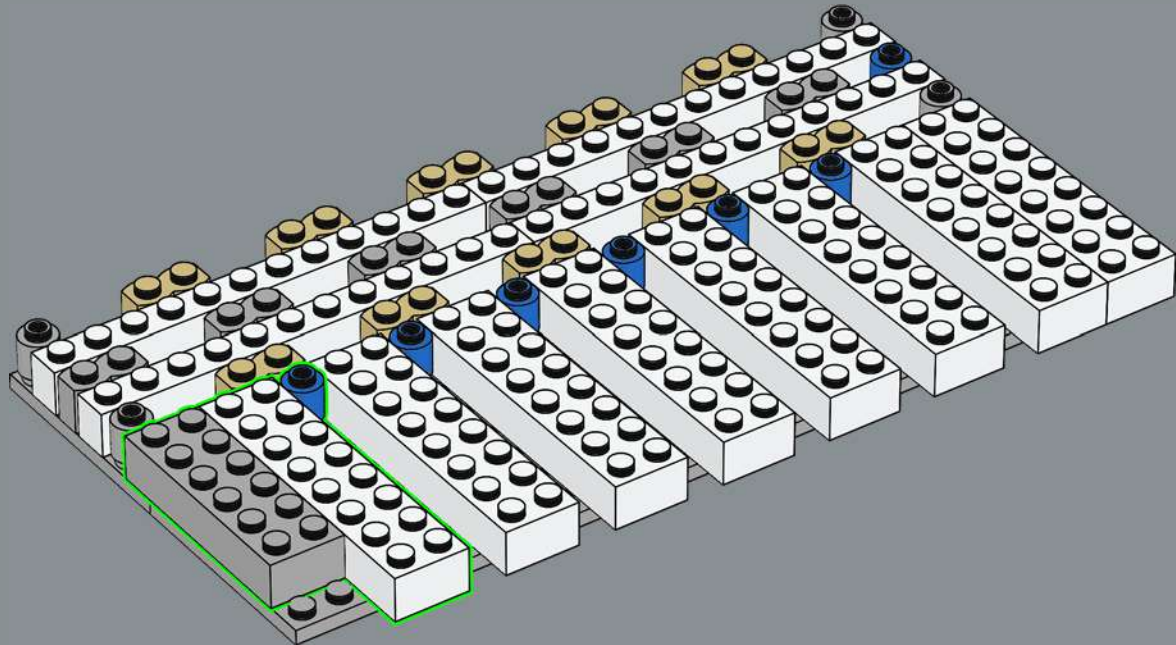

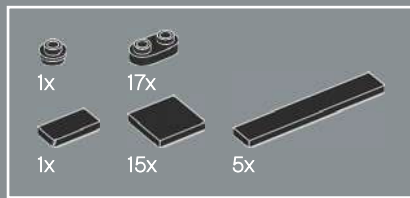

81

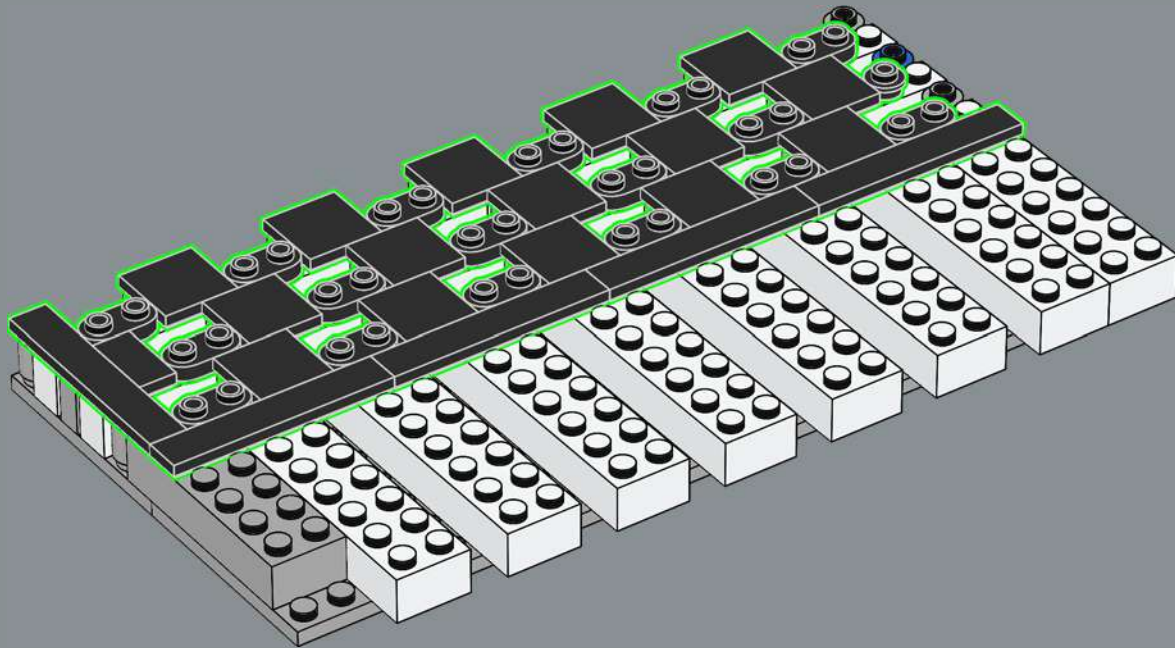

82

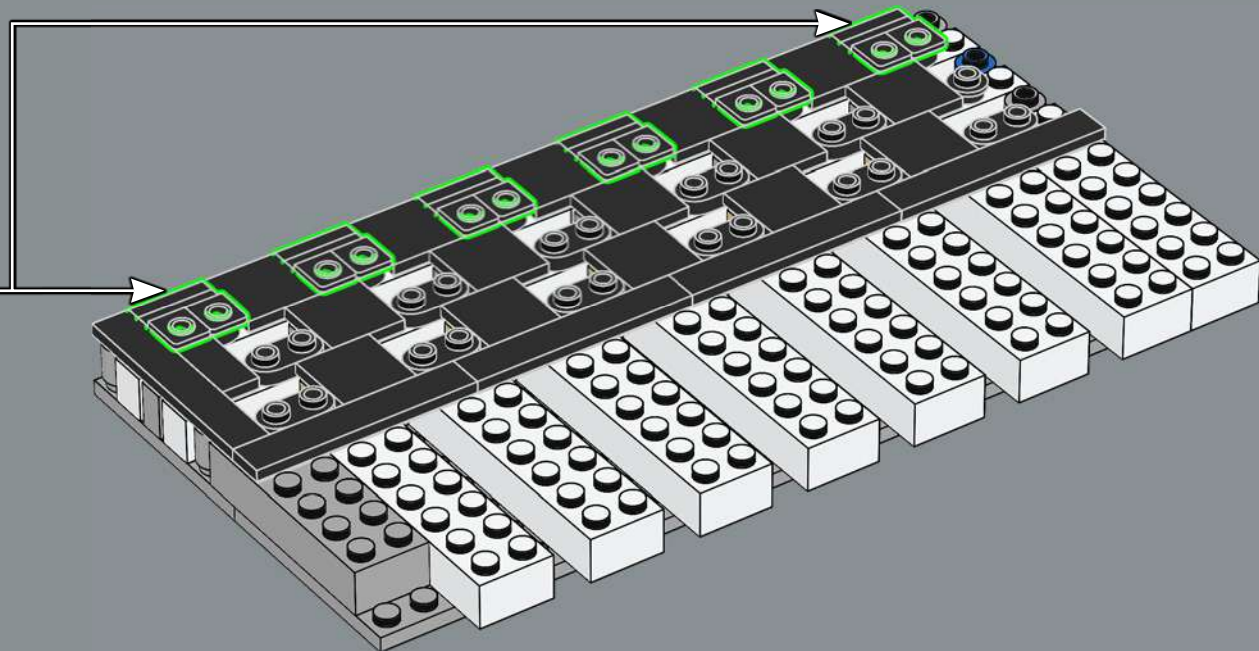
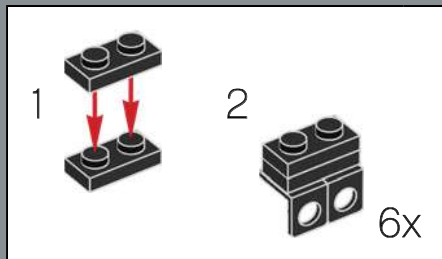



83

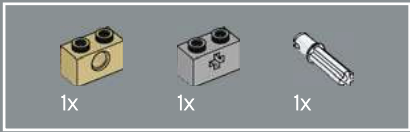
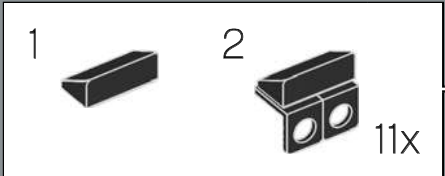
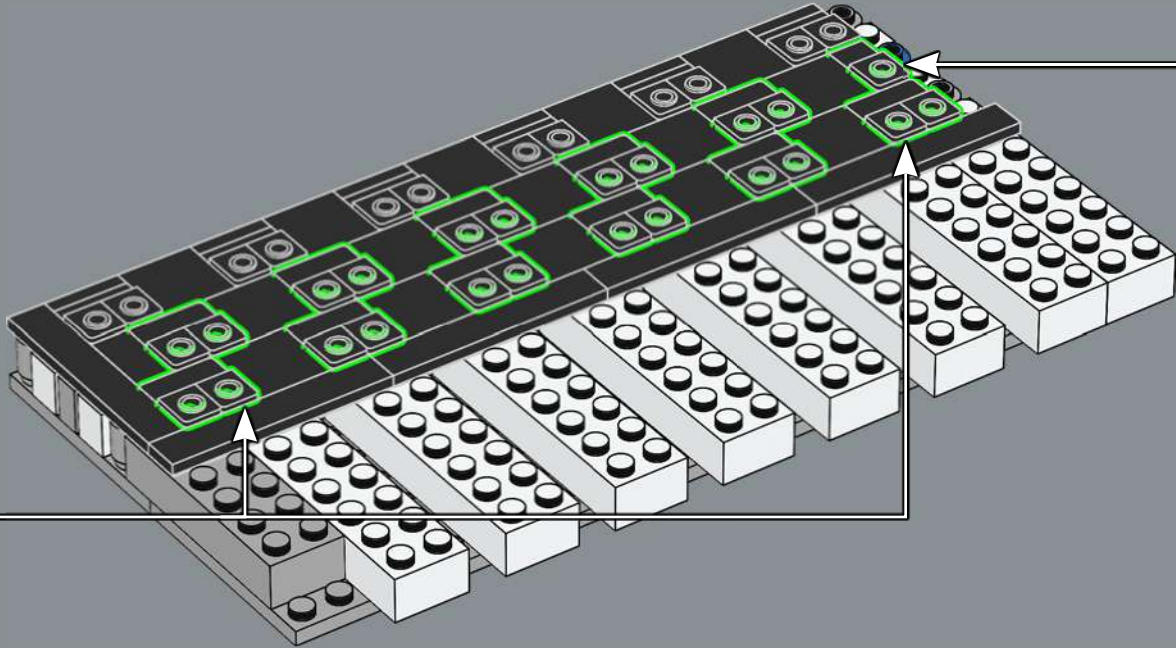
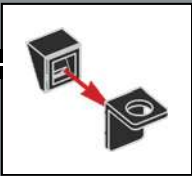

84

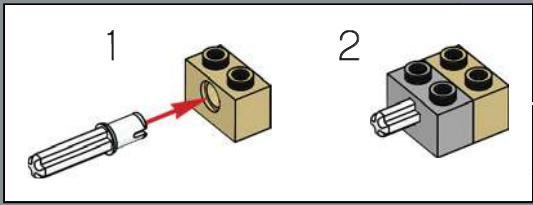
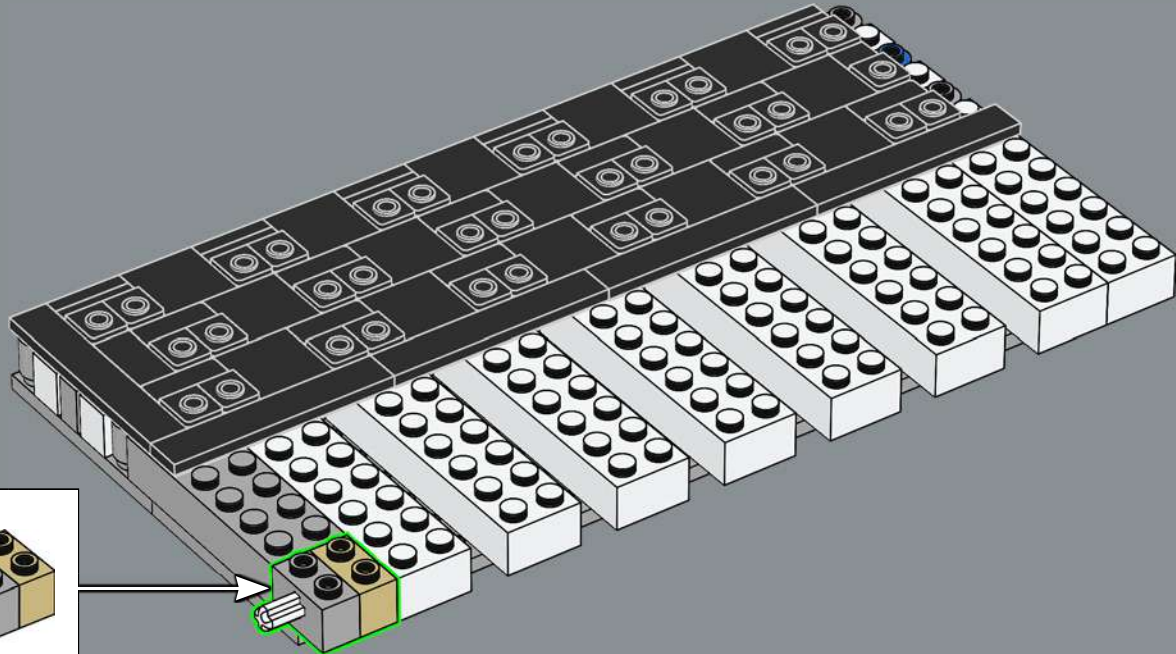

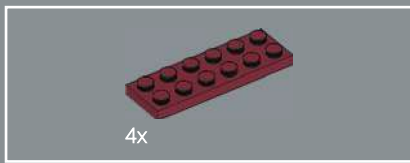

85

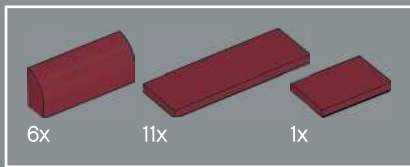
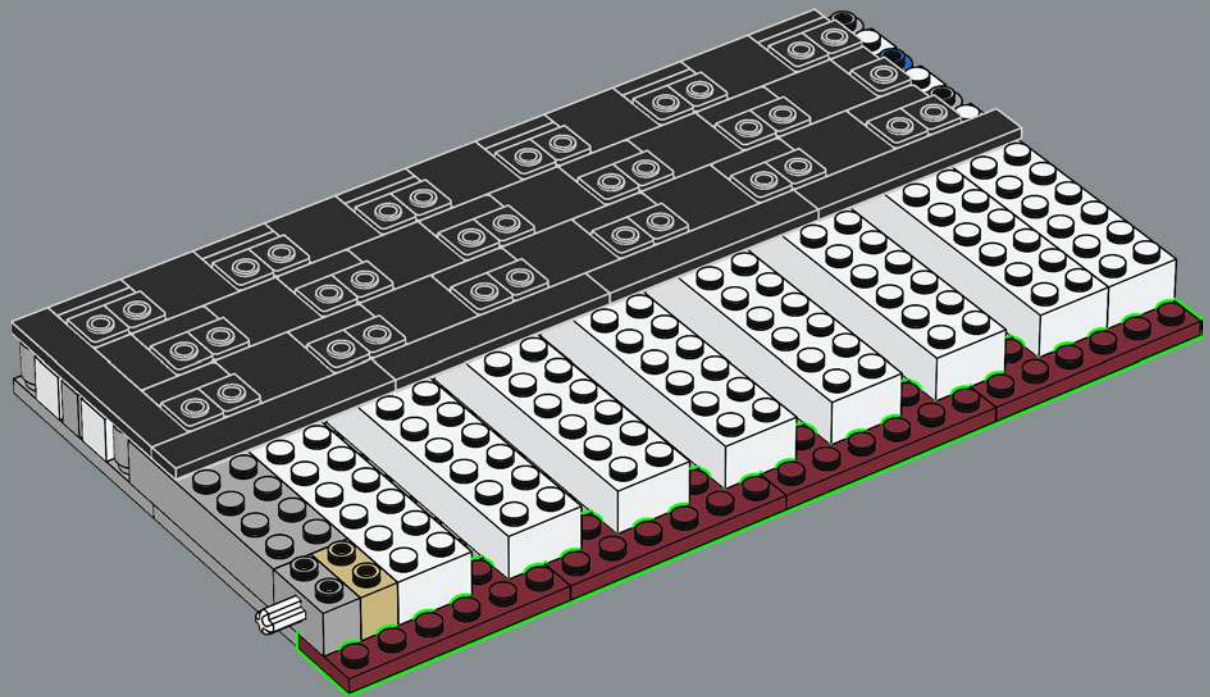

86

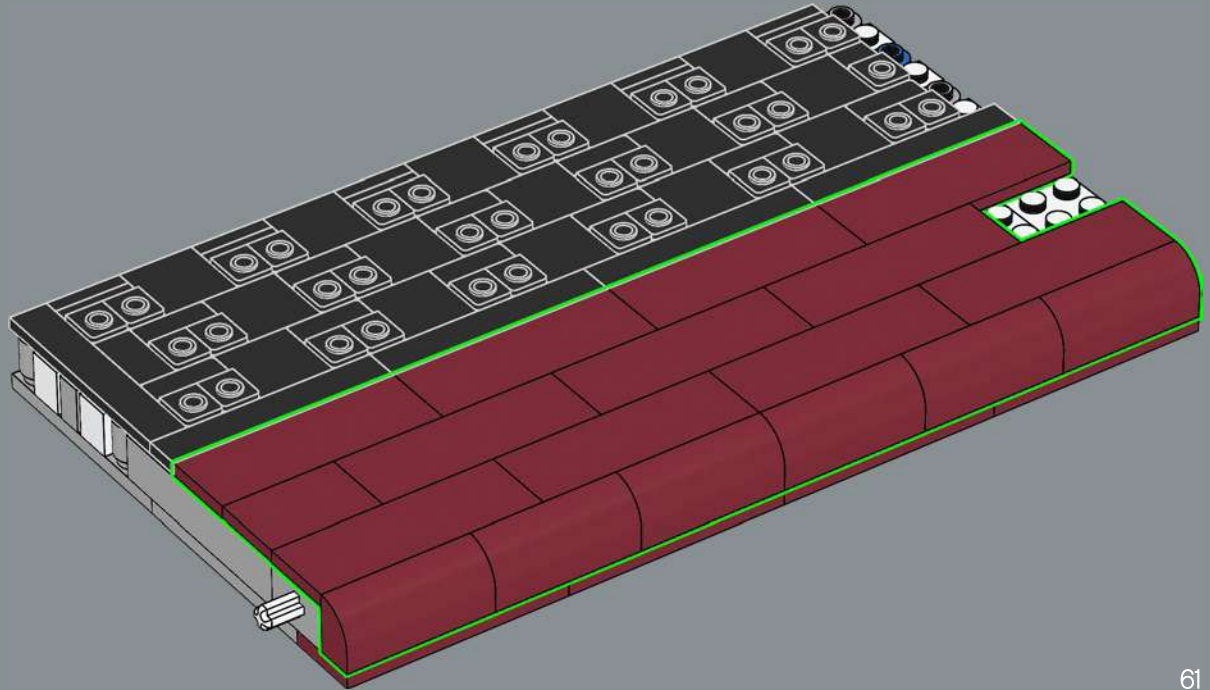

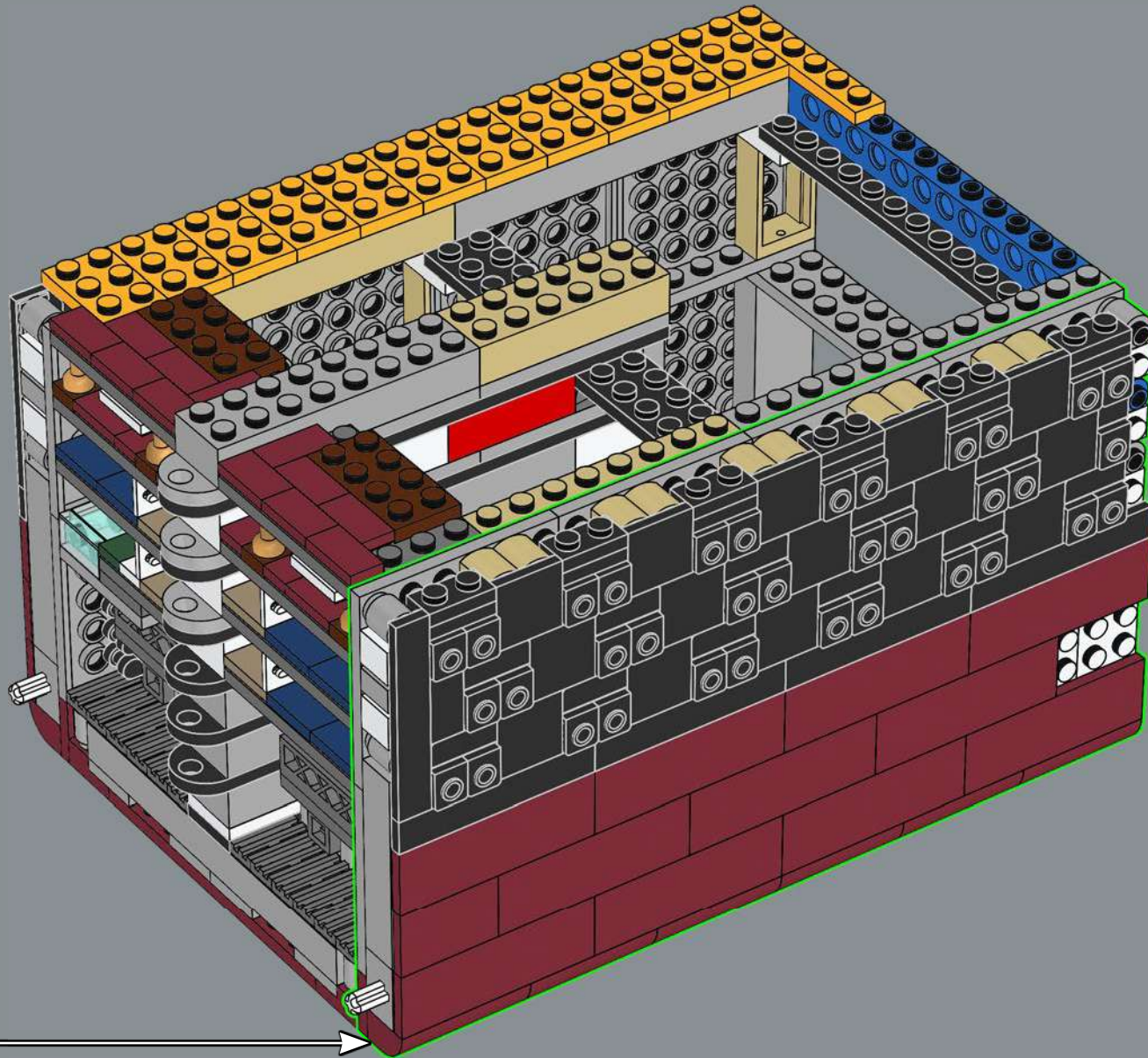

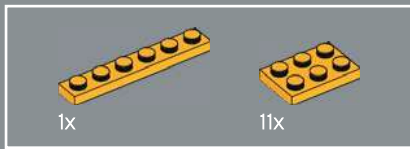

88

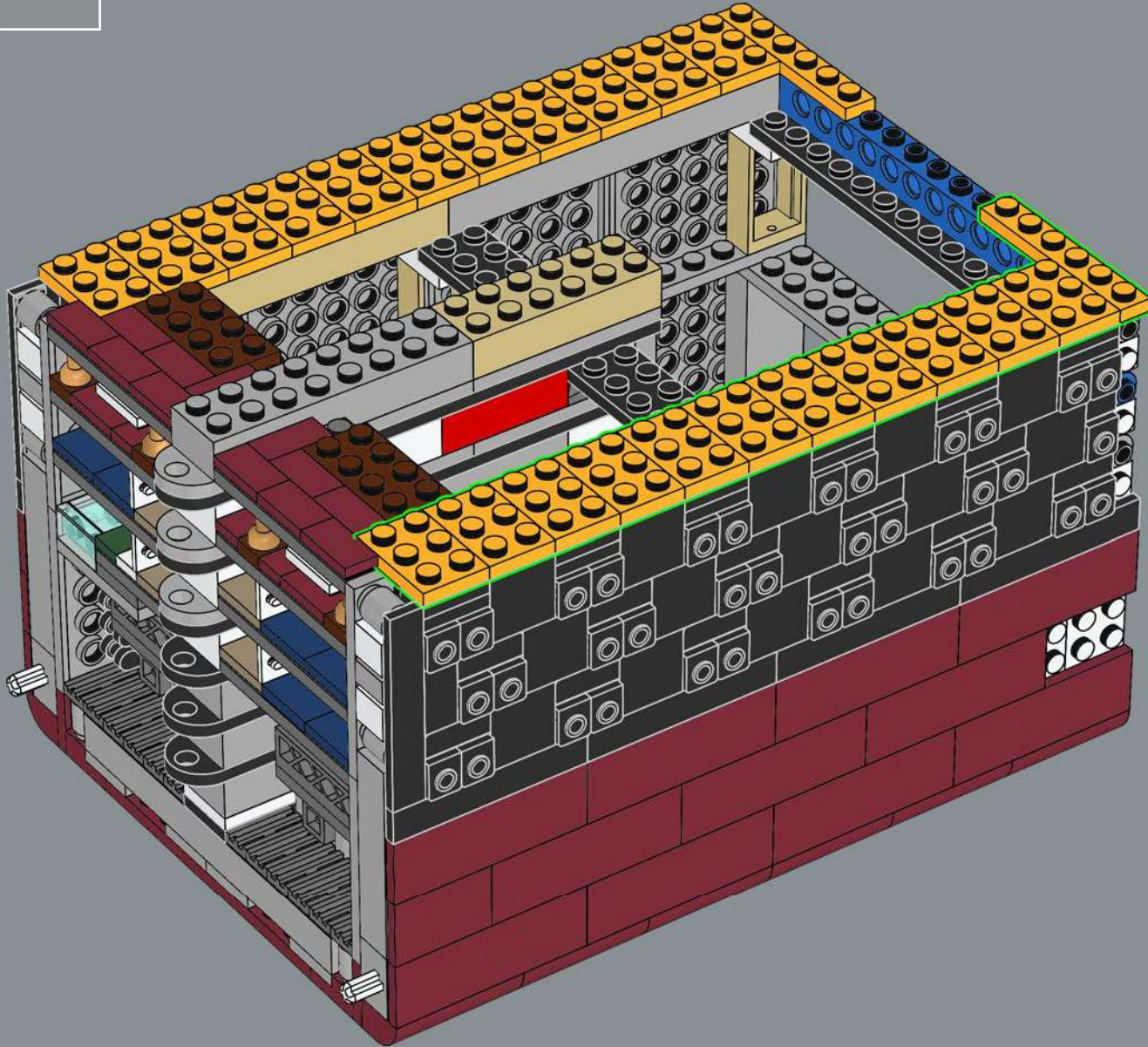

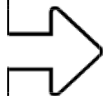

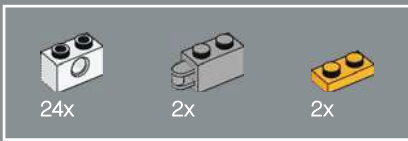

89

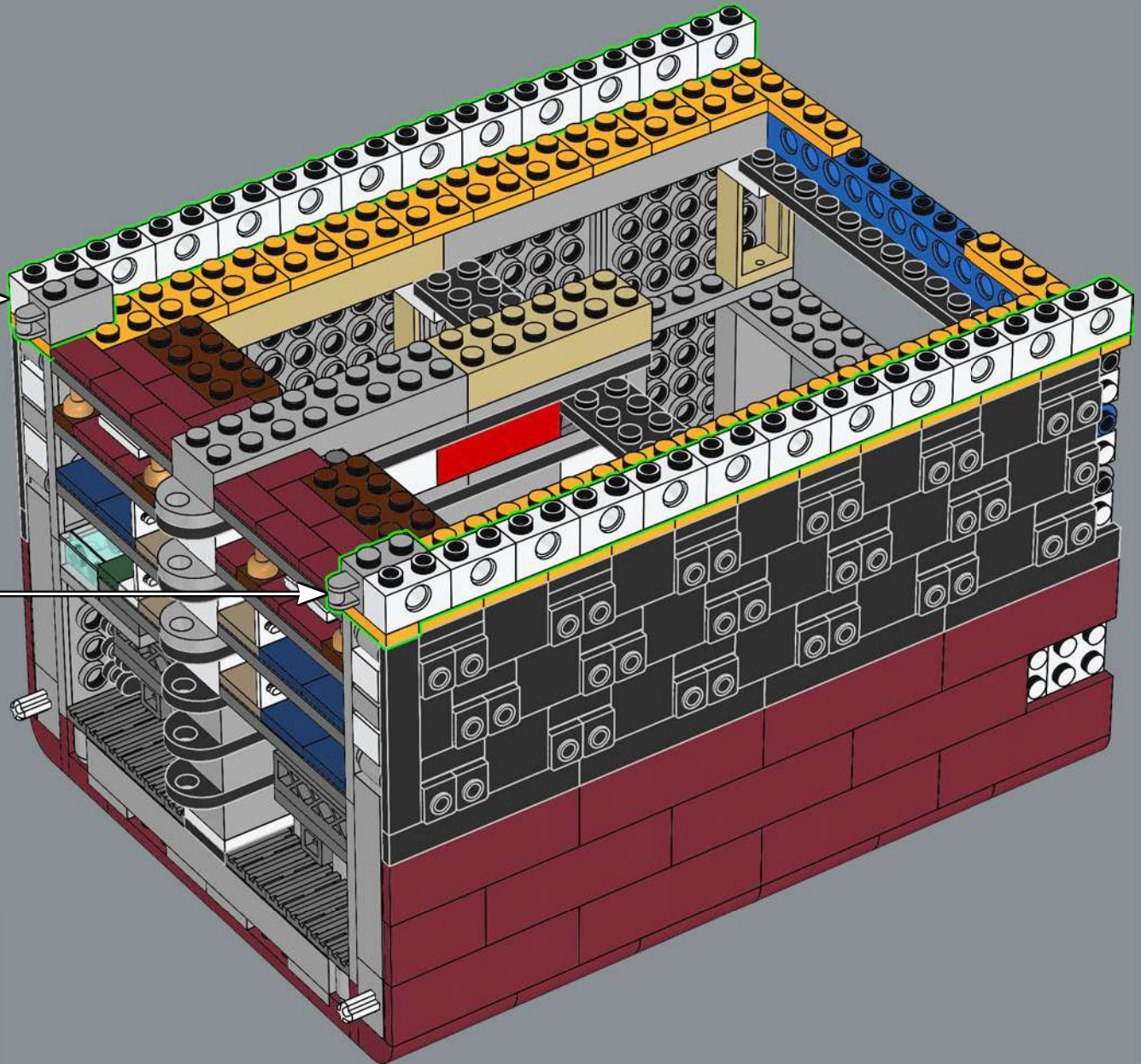
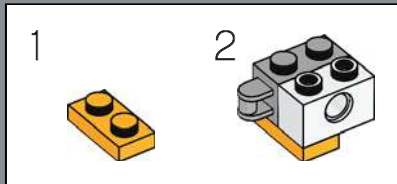
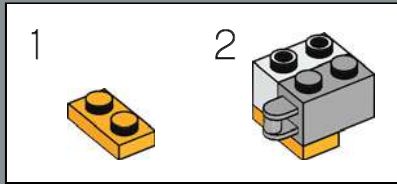

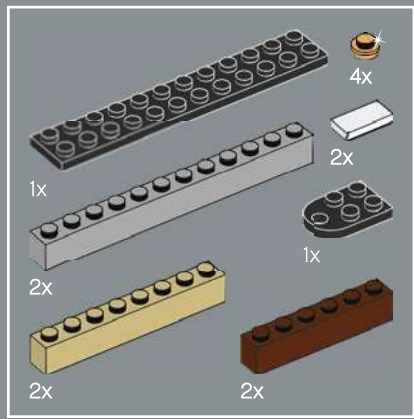

90

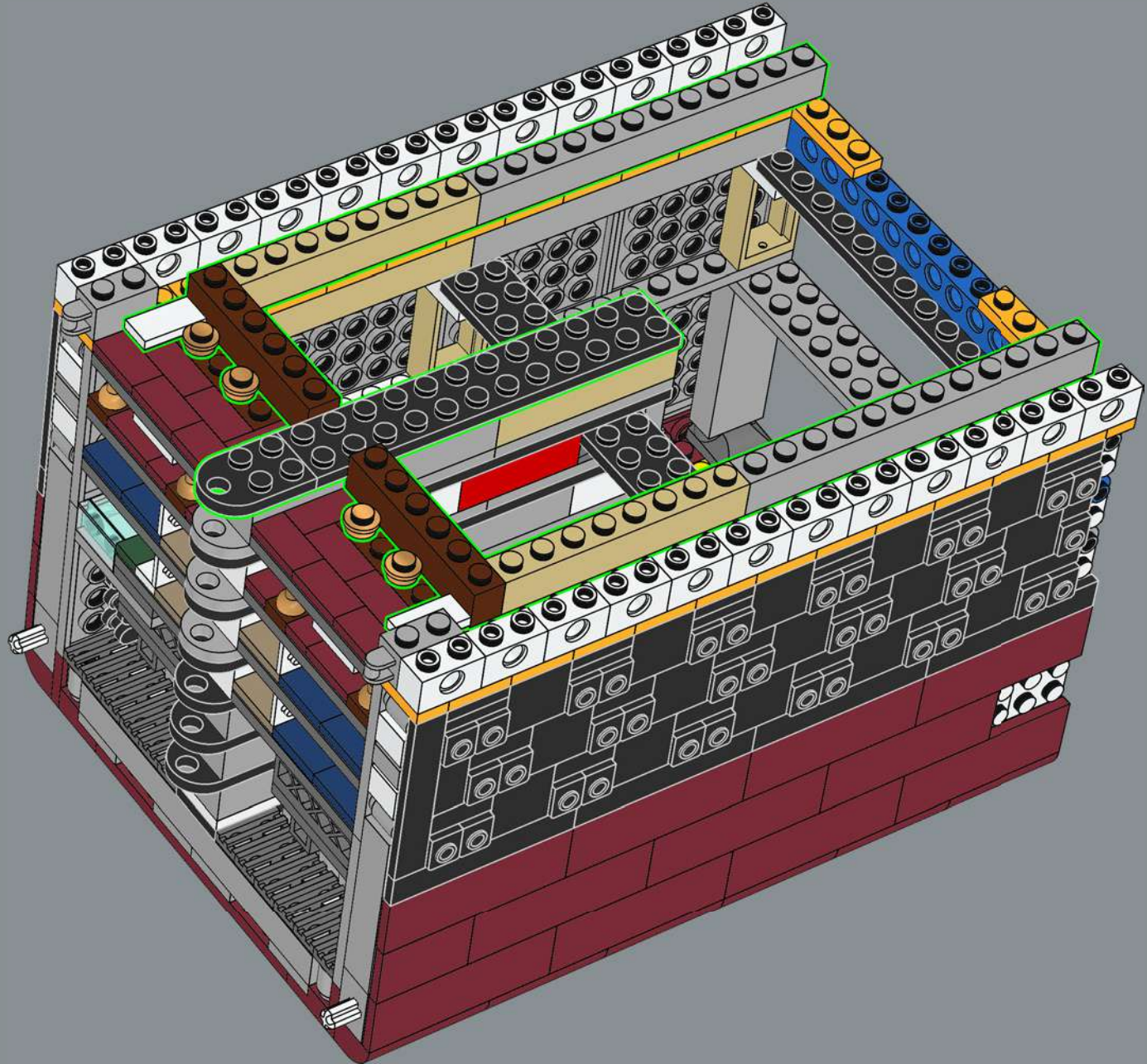

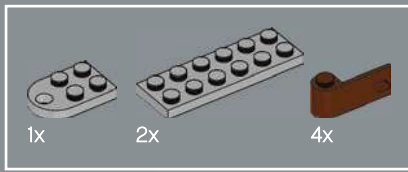

91

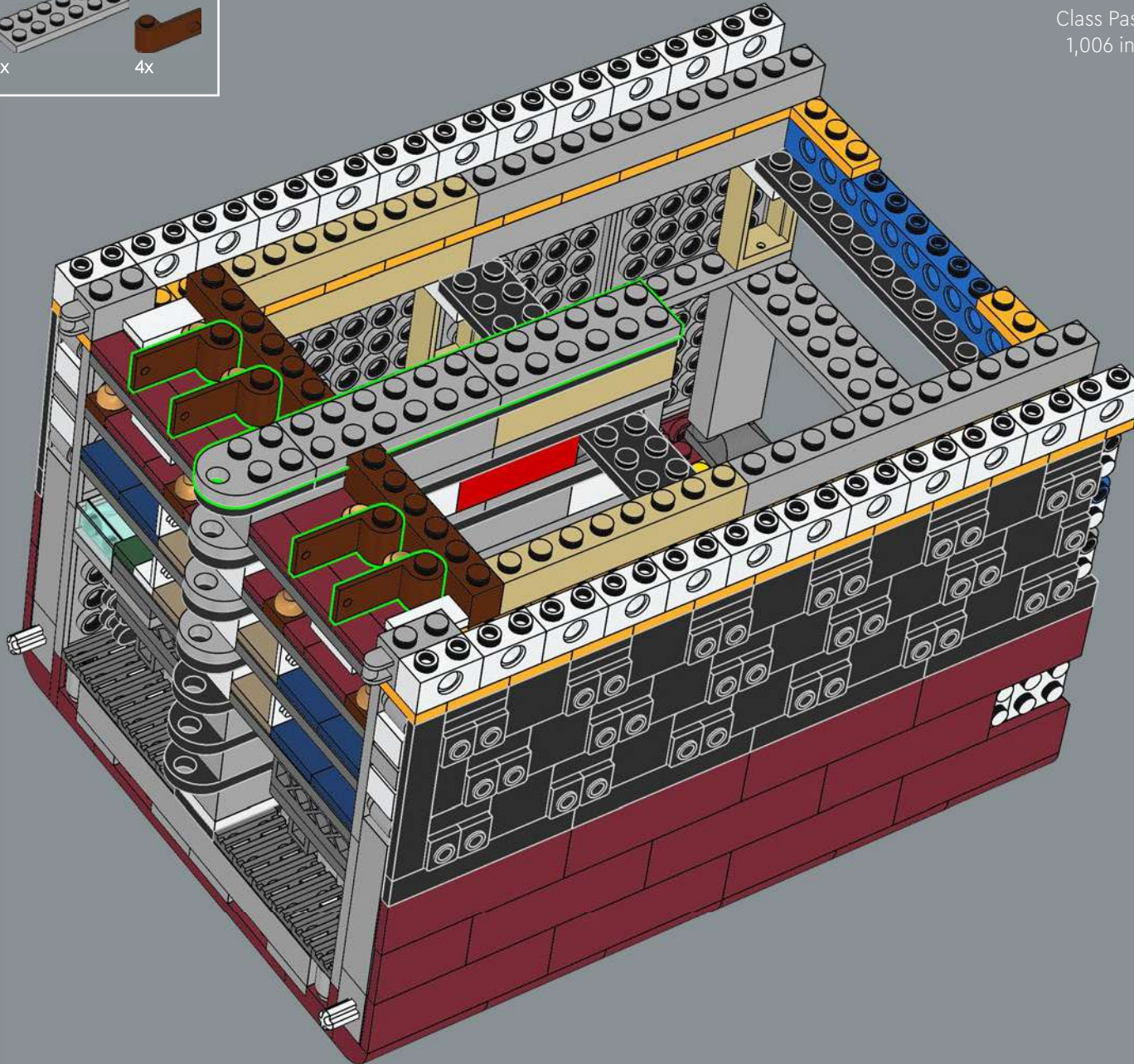

The *Titanic* could accommodate 833 First-Class Passengers, 614 in Second Class and 1,006 in Third Class, for a total passenger capacity of 2,453.

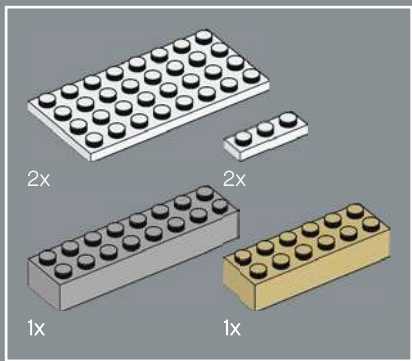

92

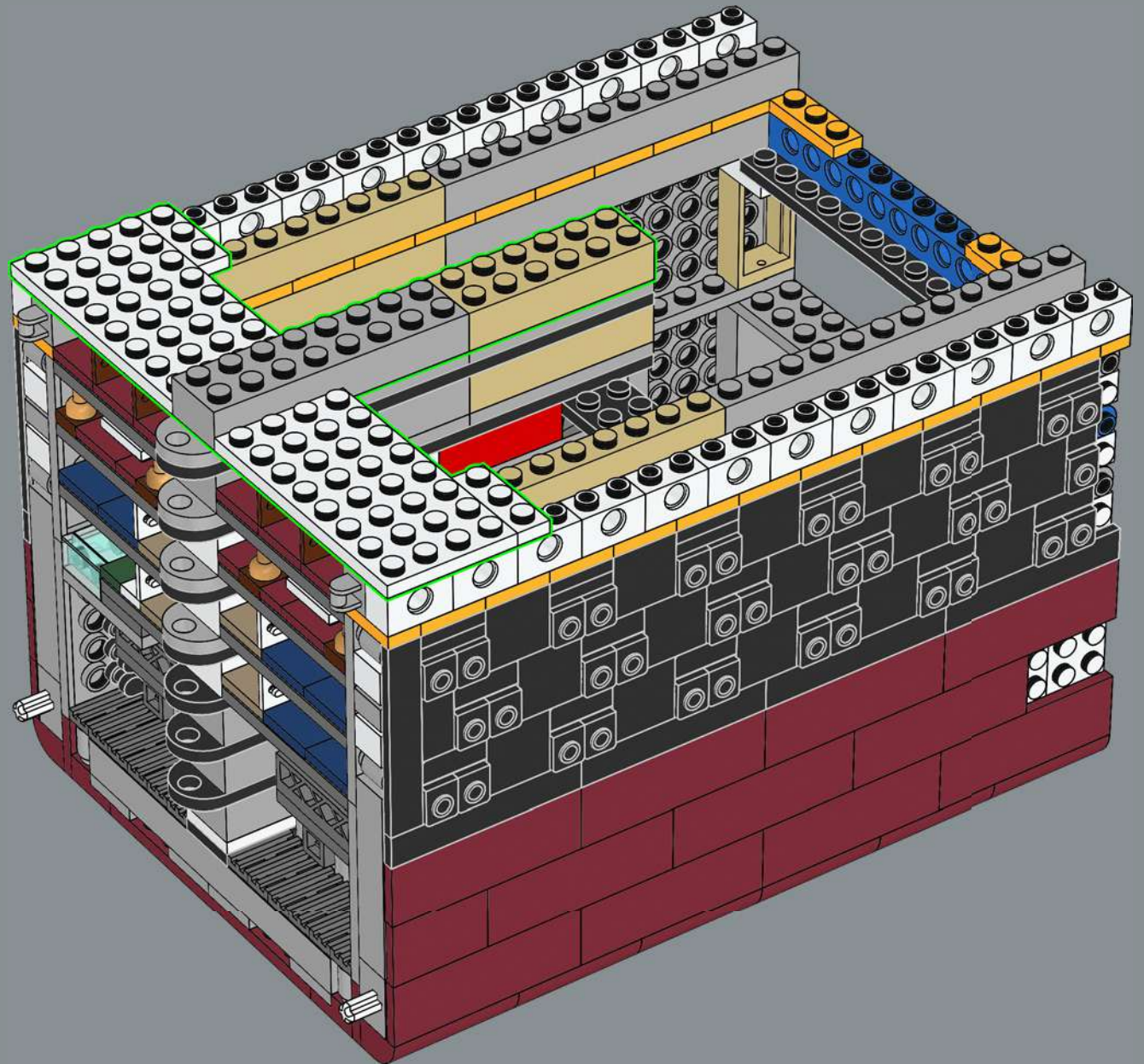



93

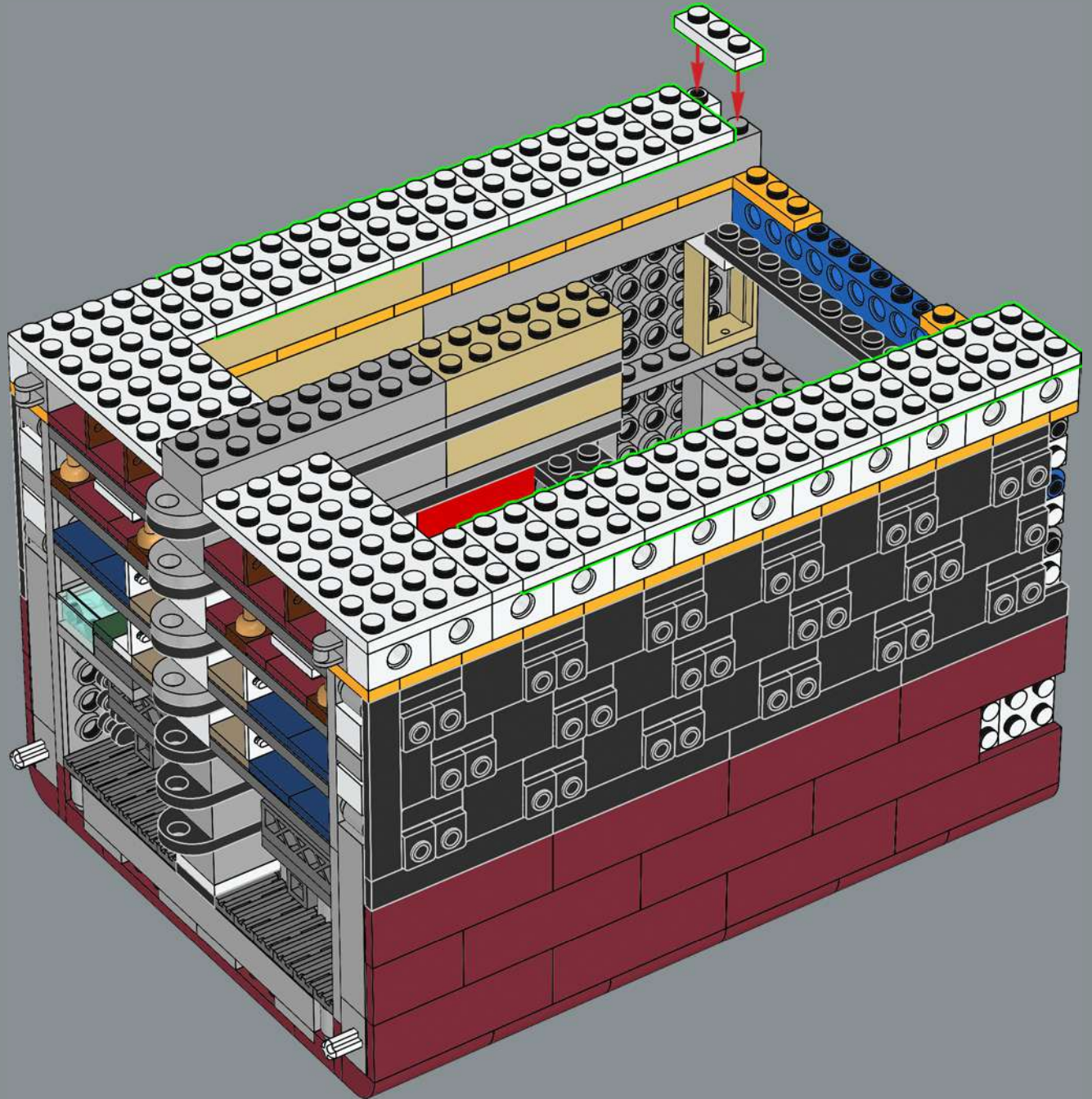

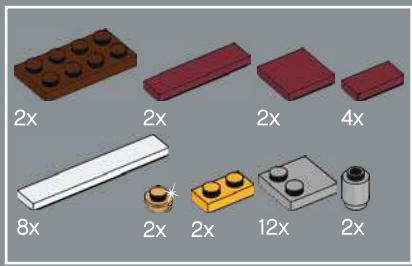

94

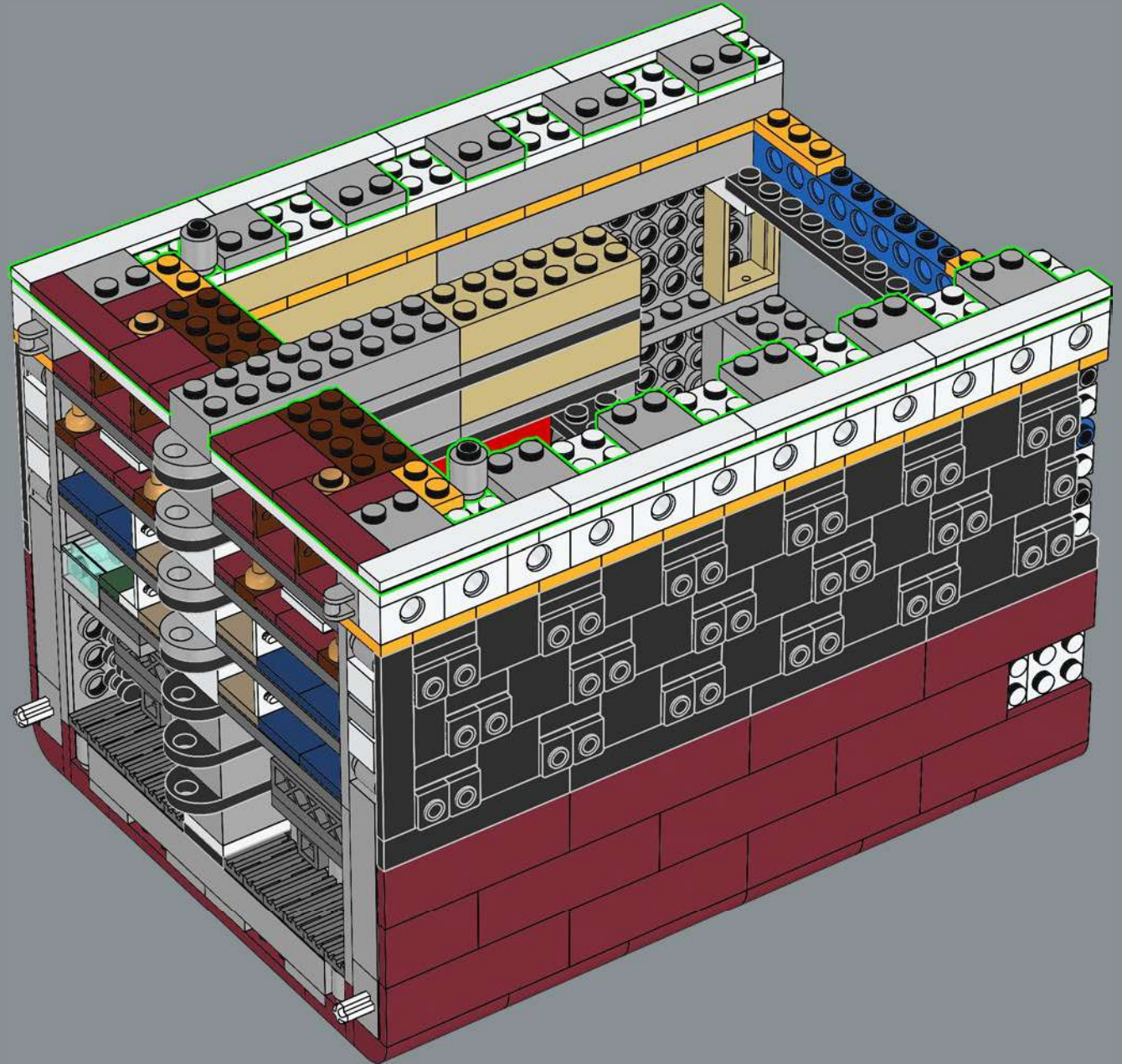

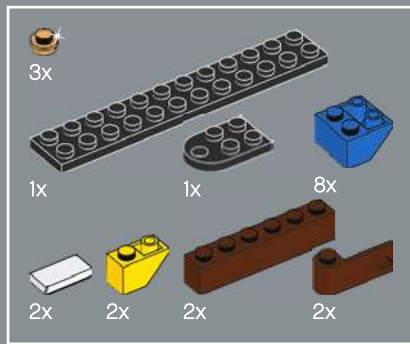

95

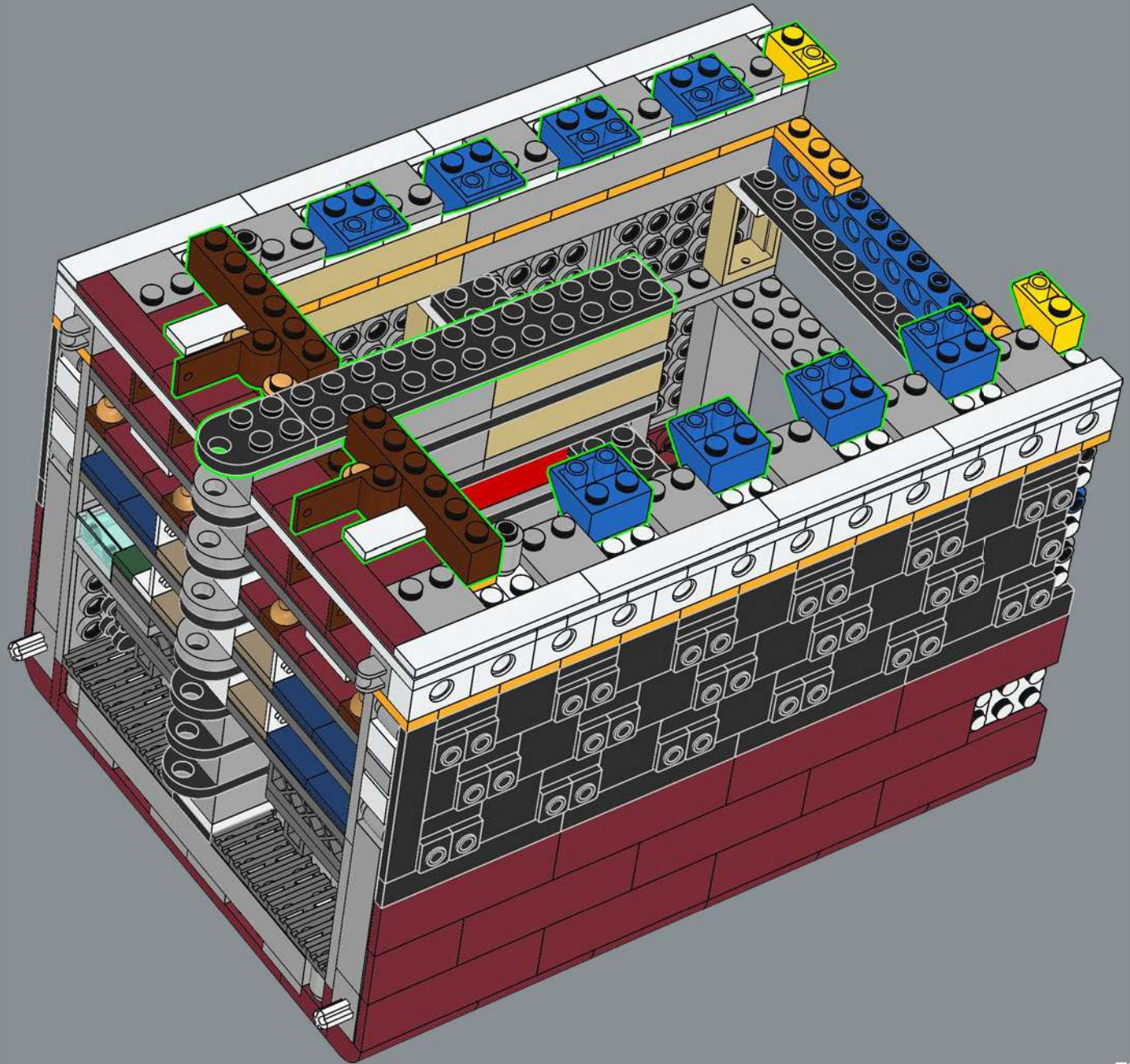

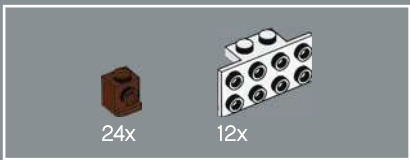

96

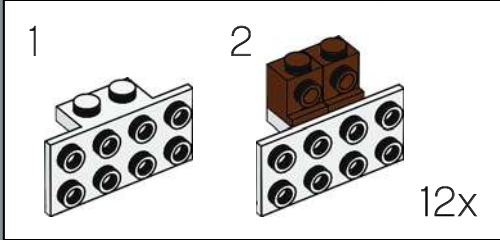
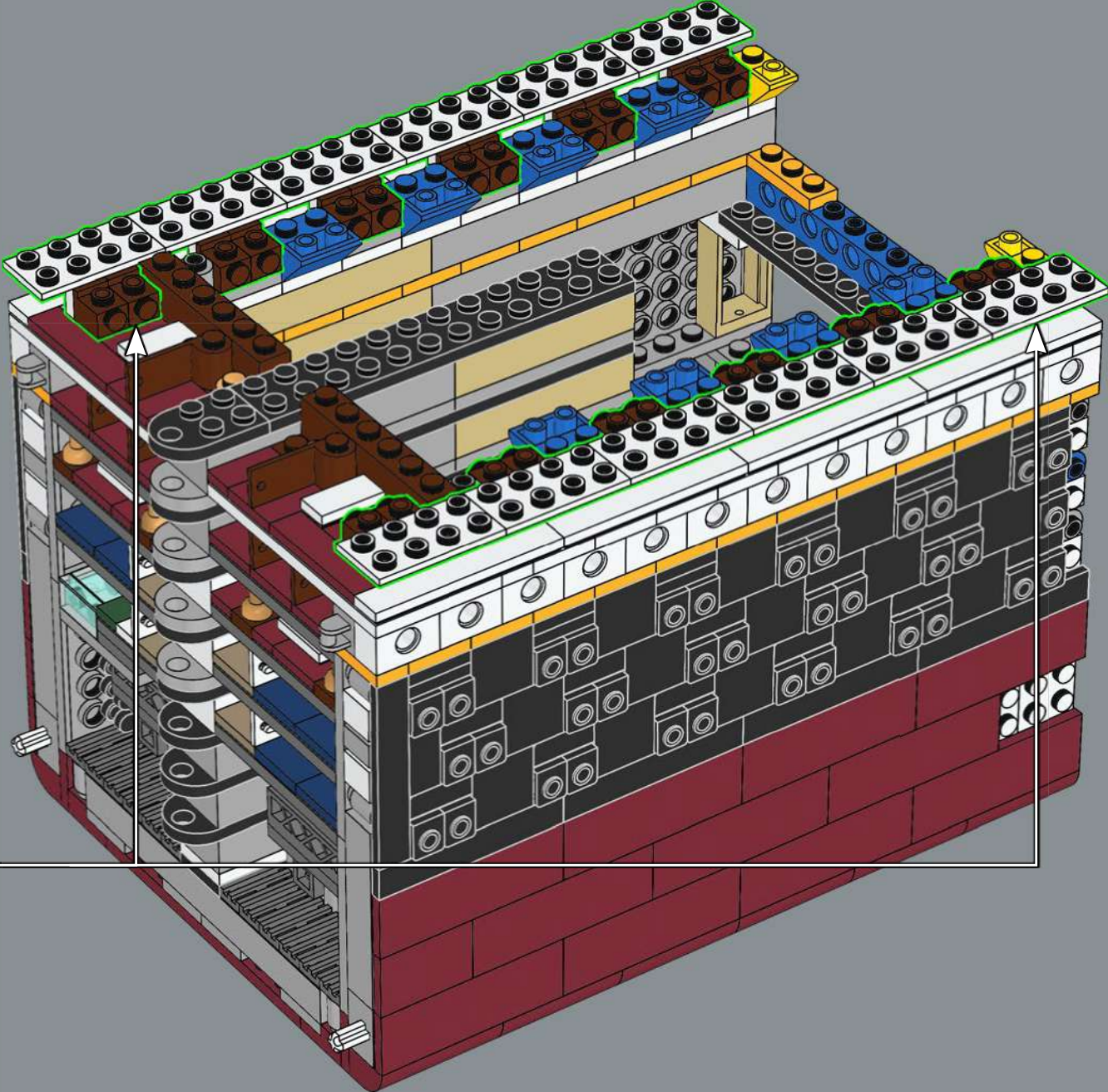

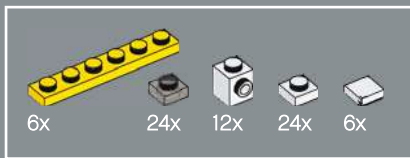

97

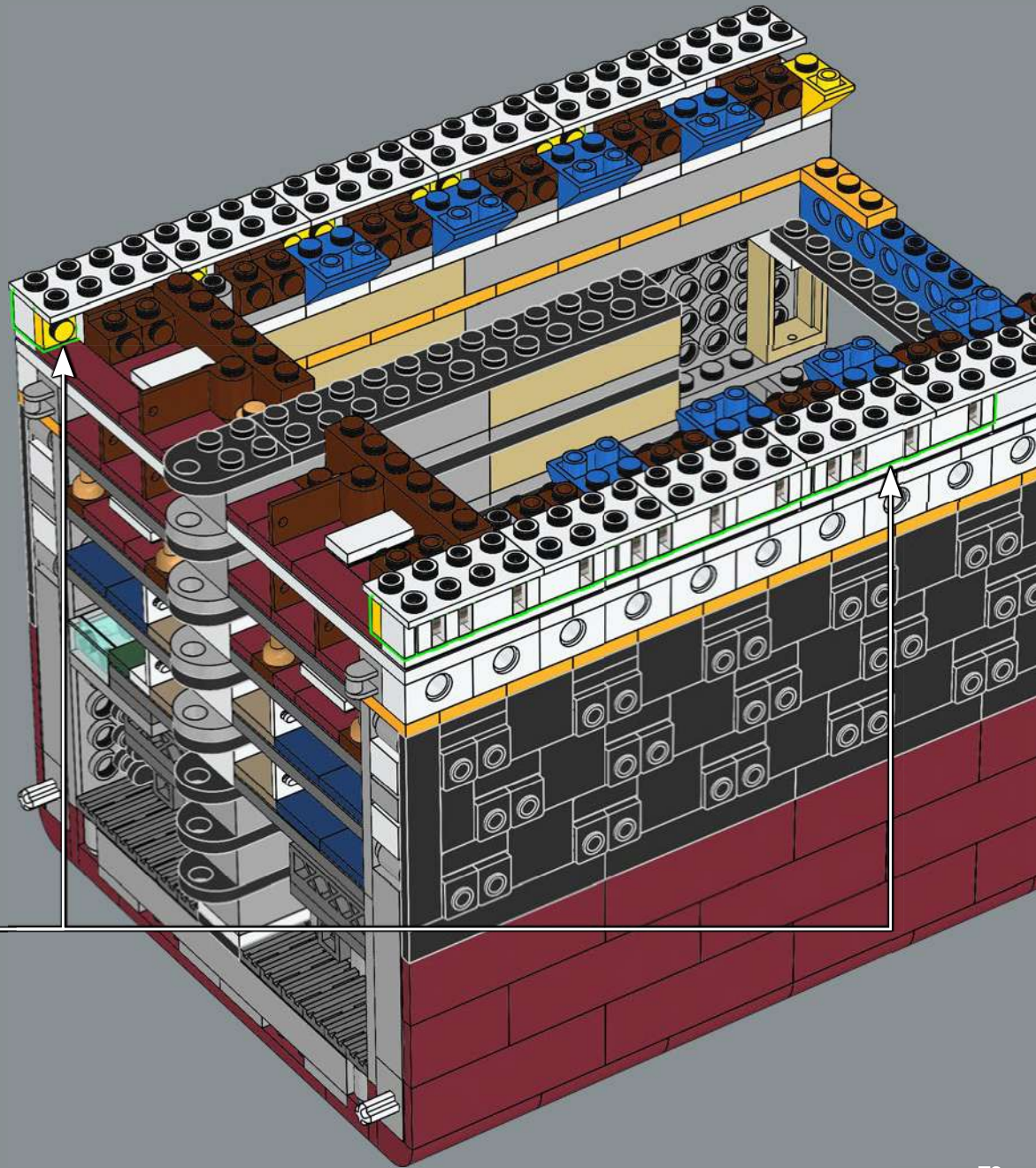
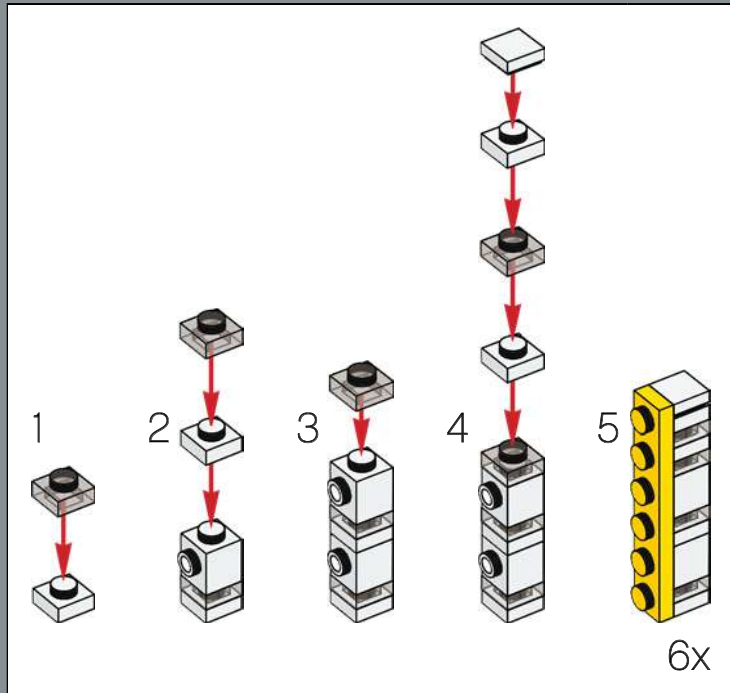

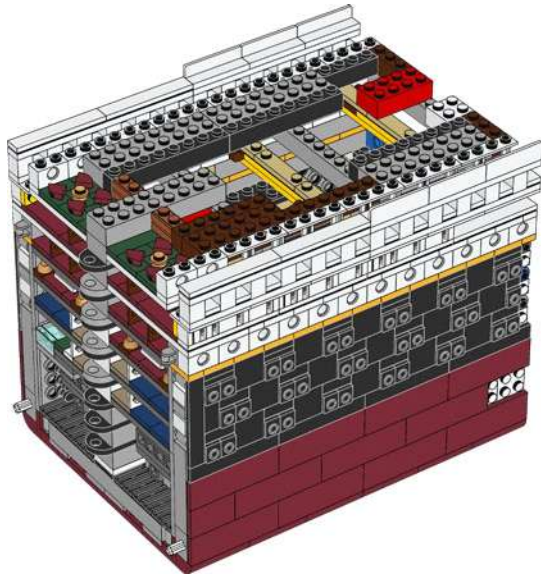
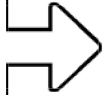

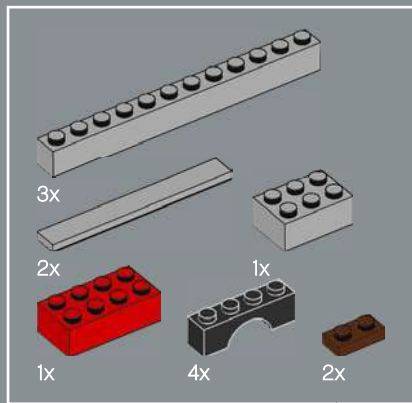

98

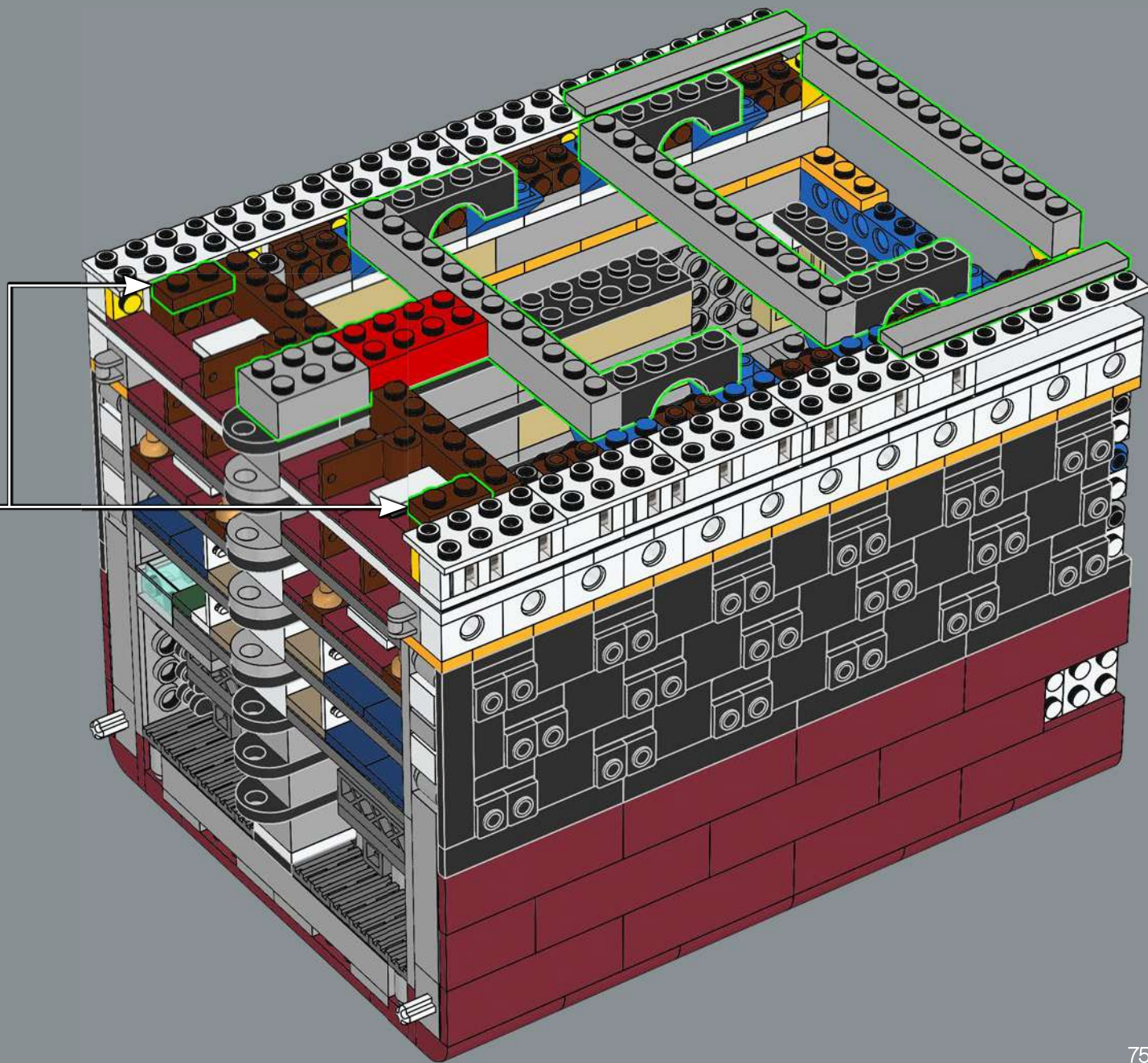

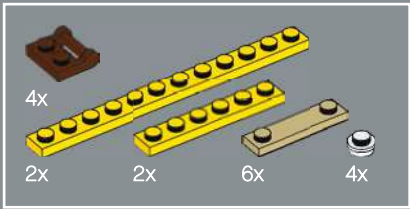

99

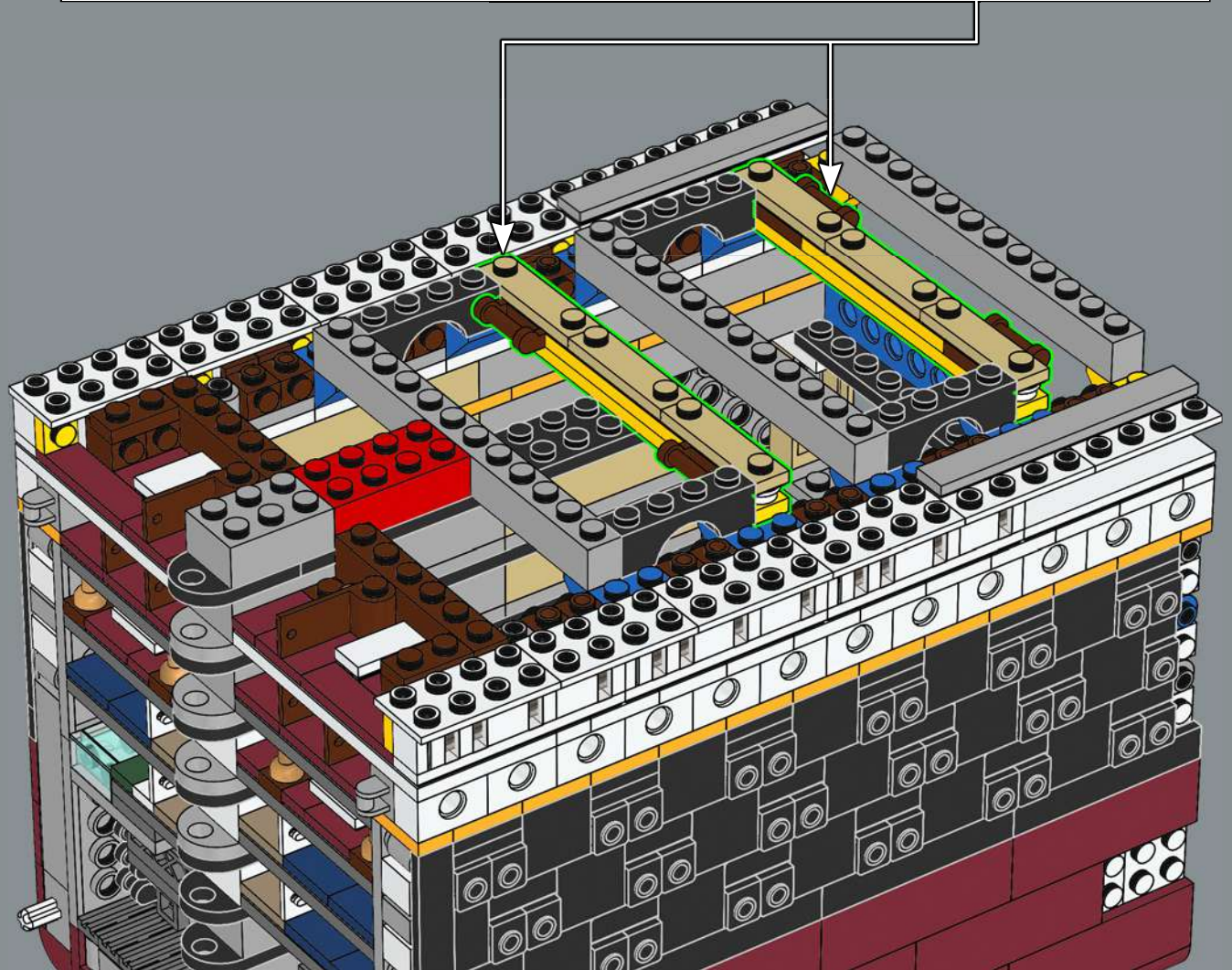
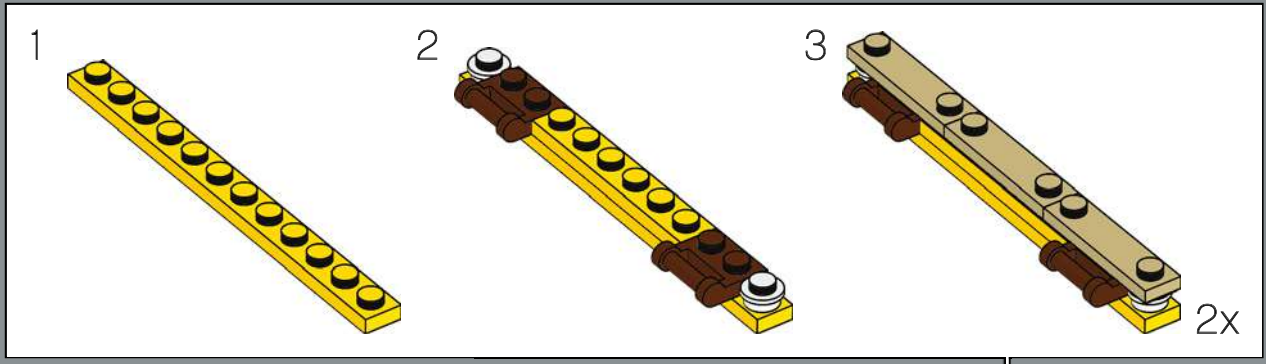

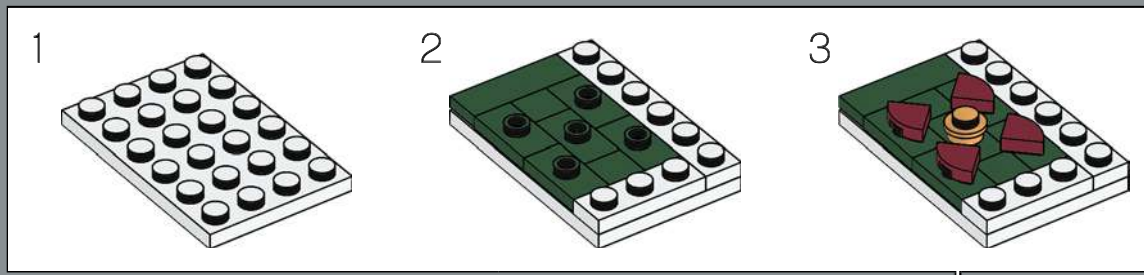
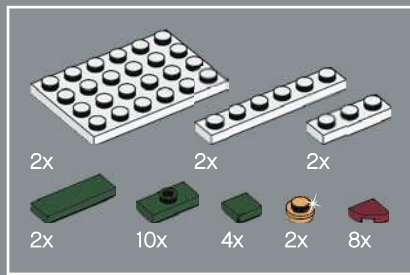

100

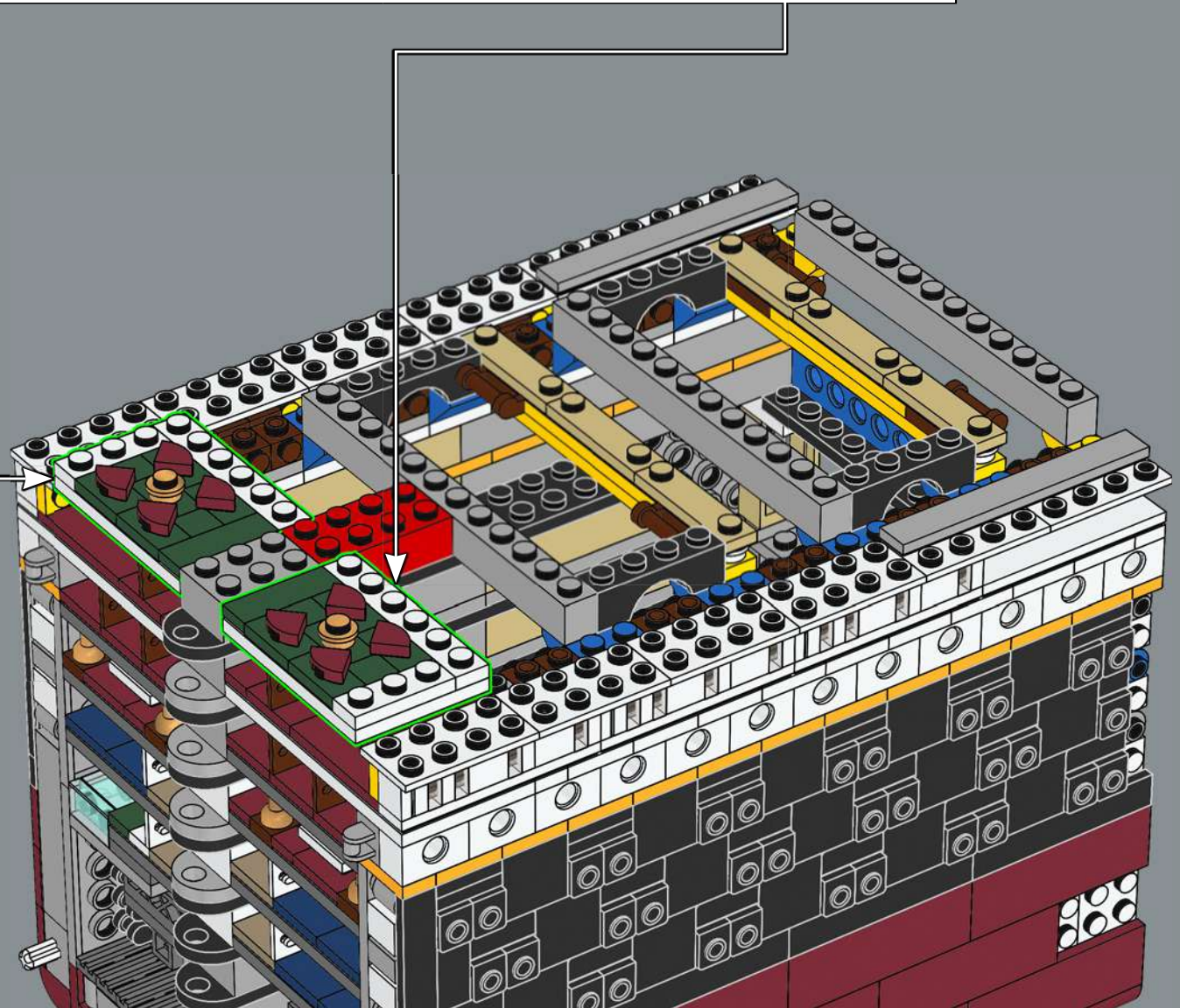
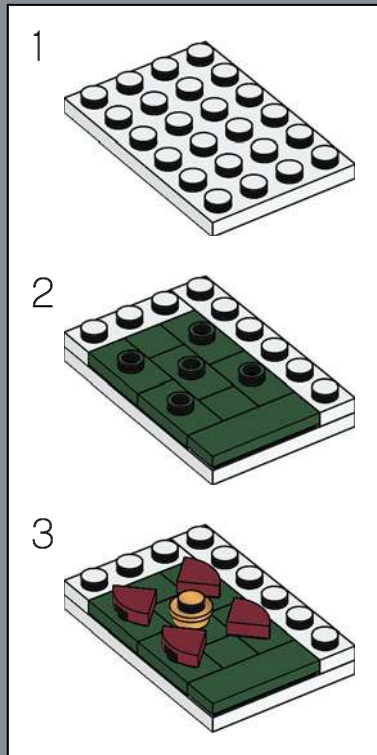

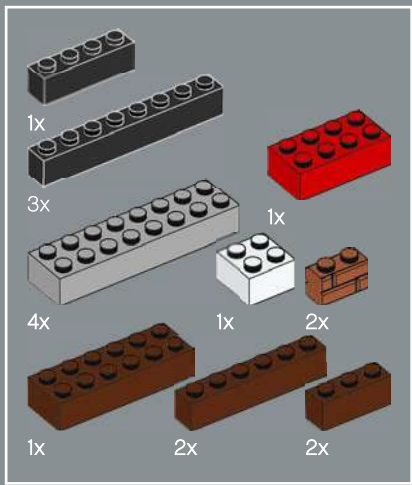

101

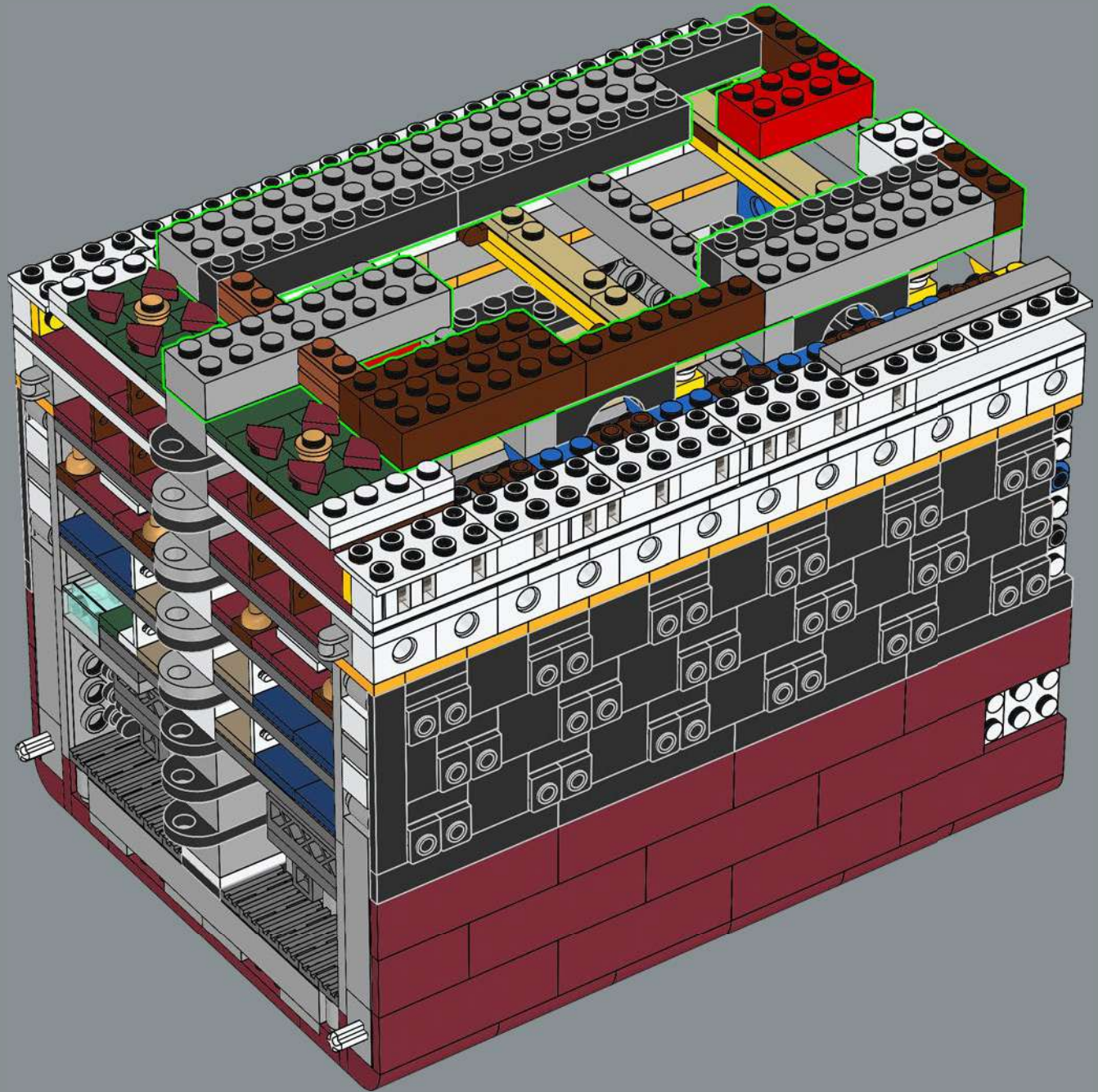

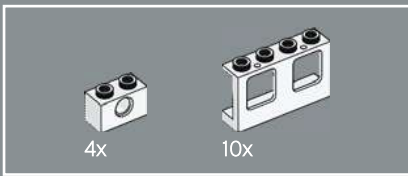

102

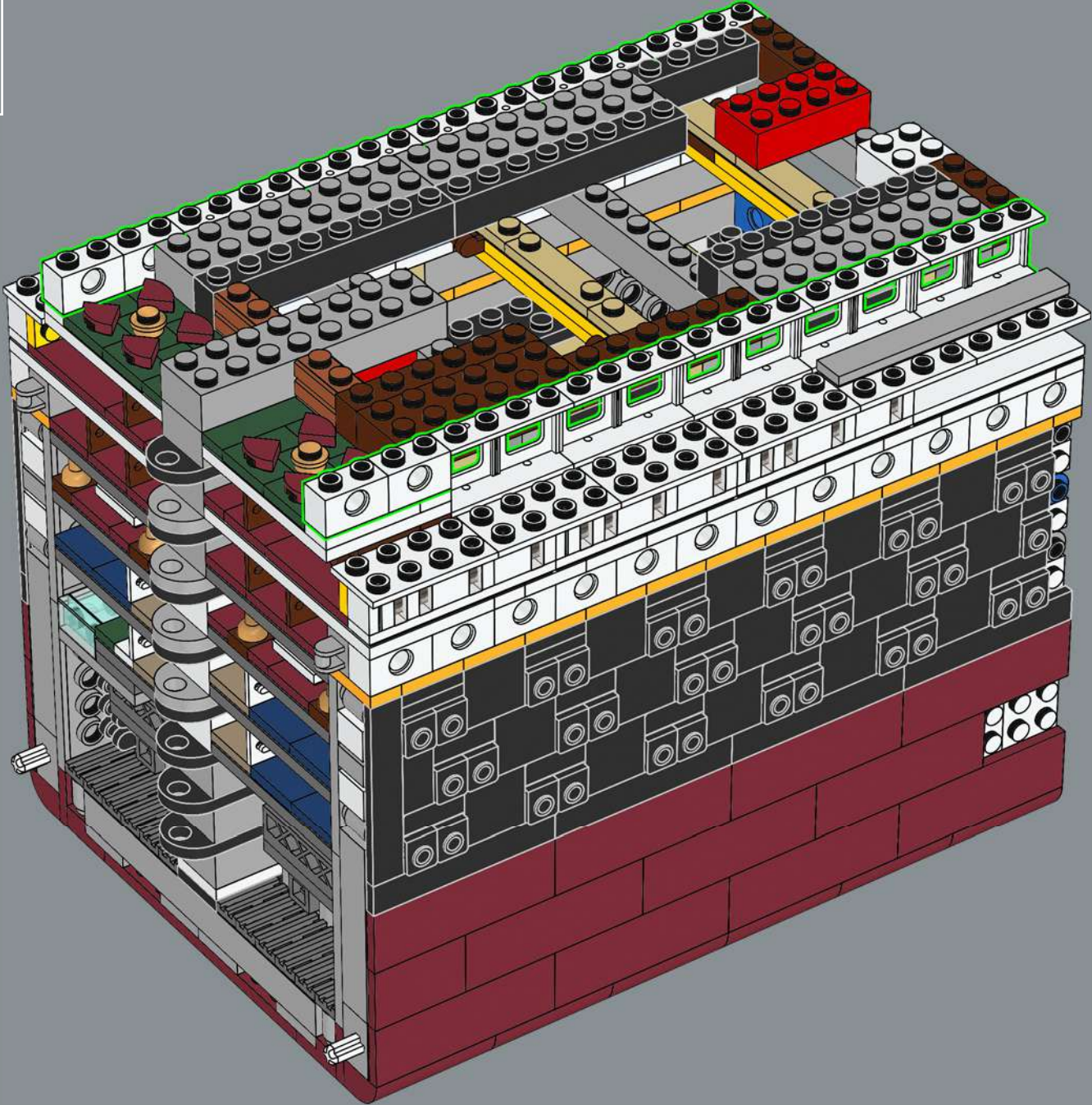

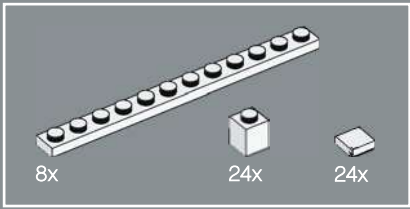

103

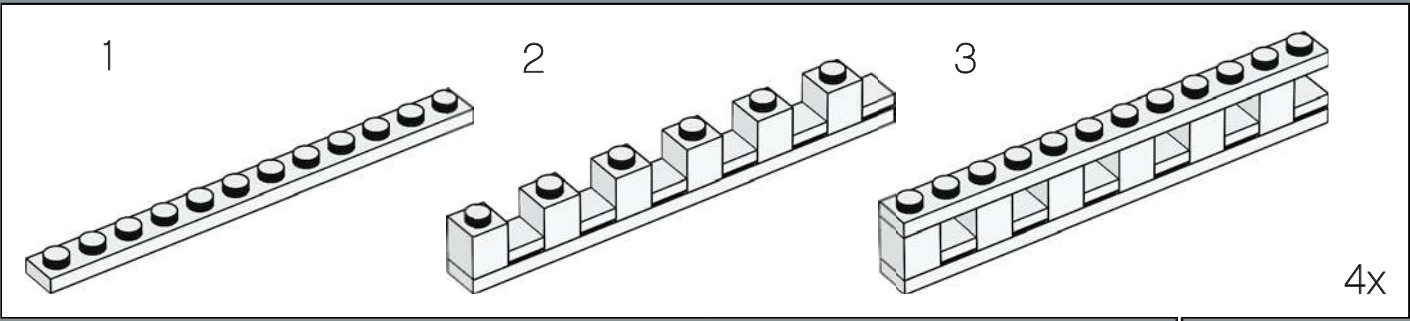

4x

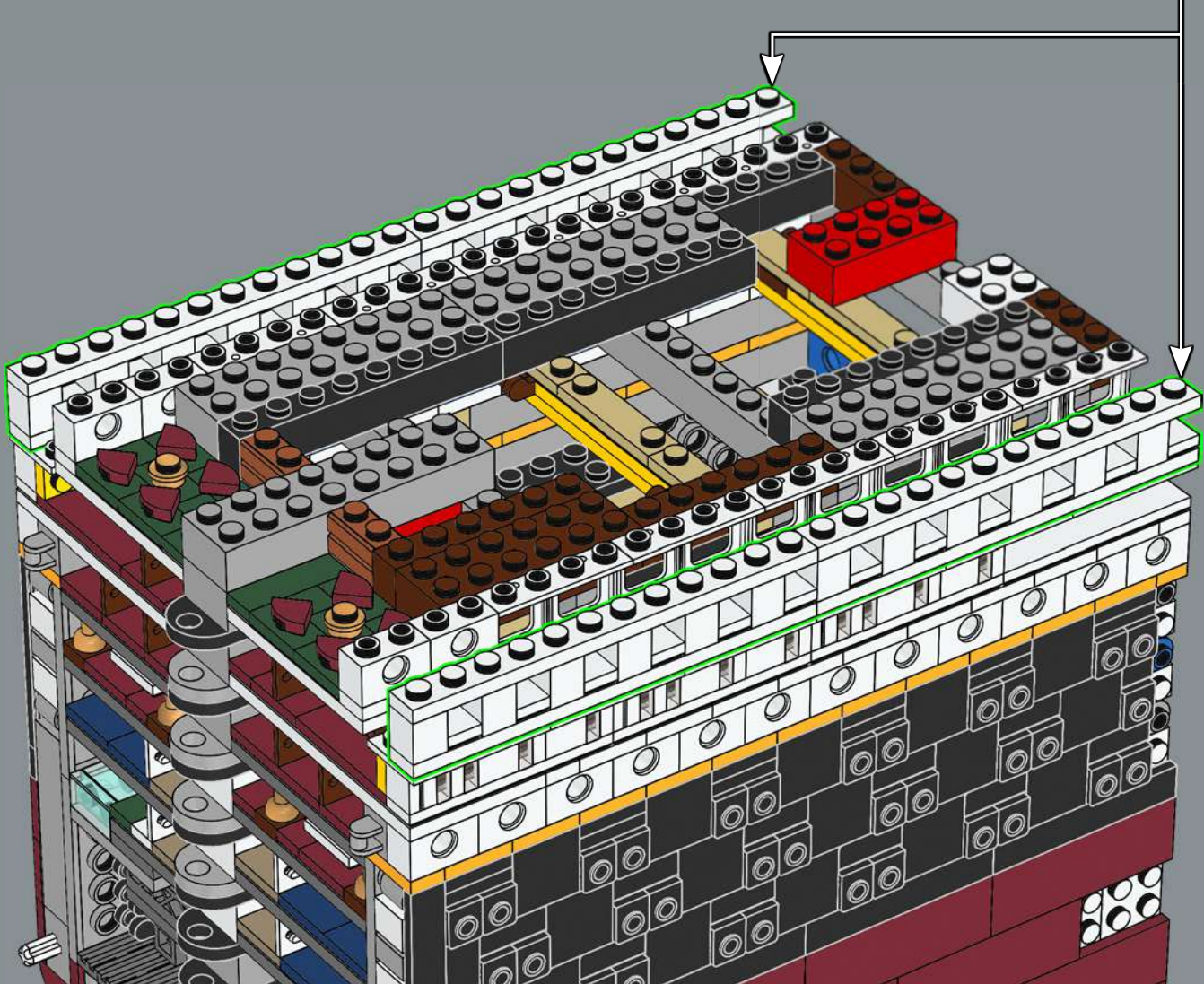

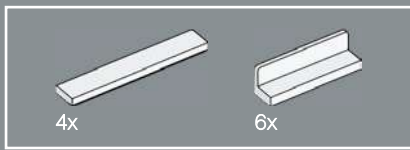

104

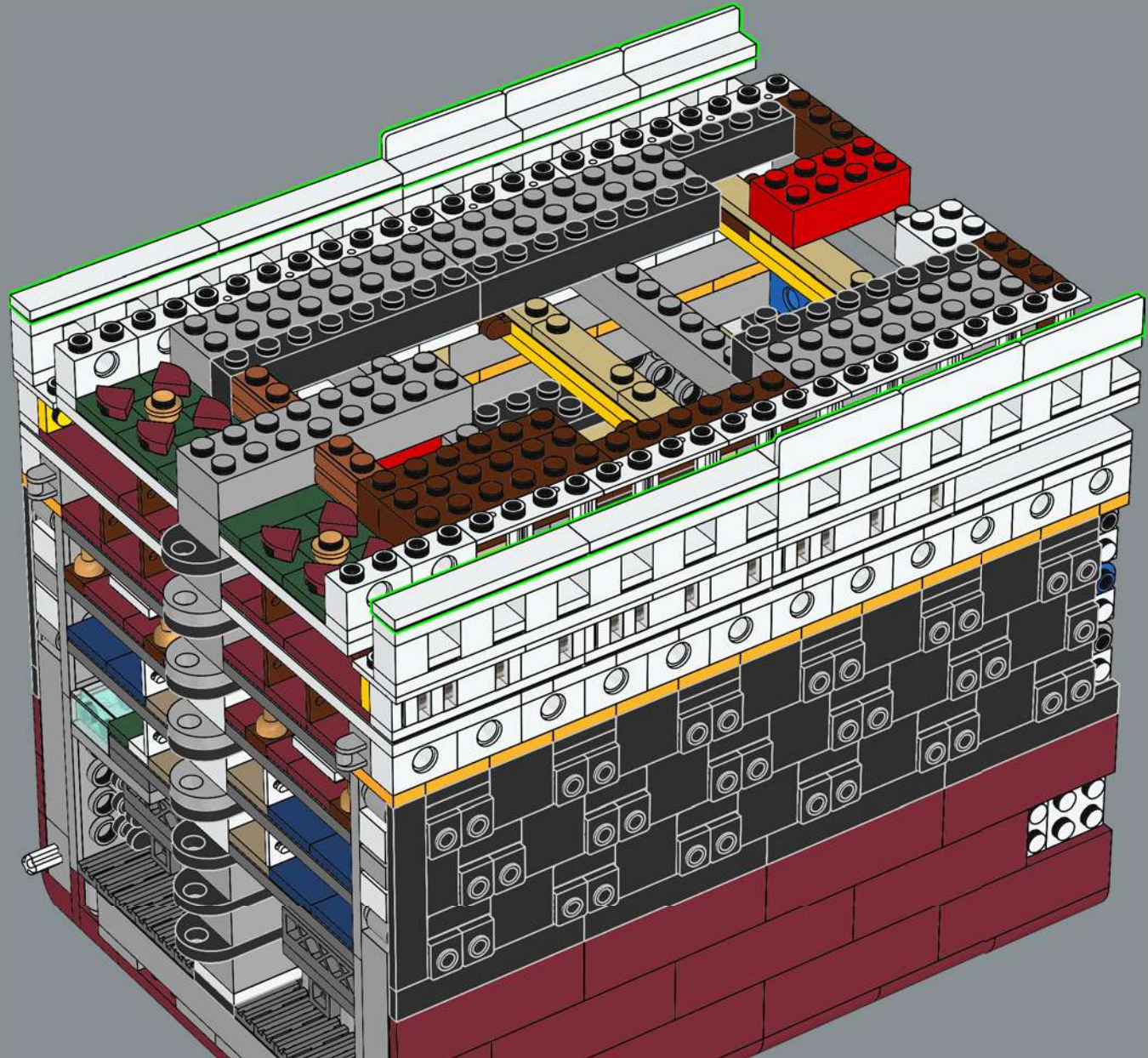

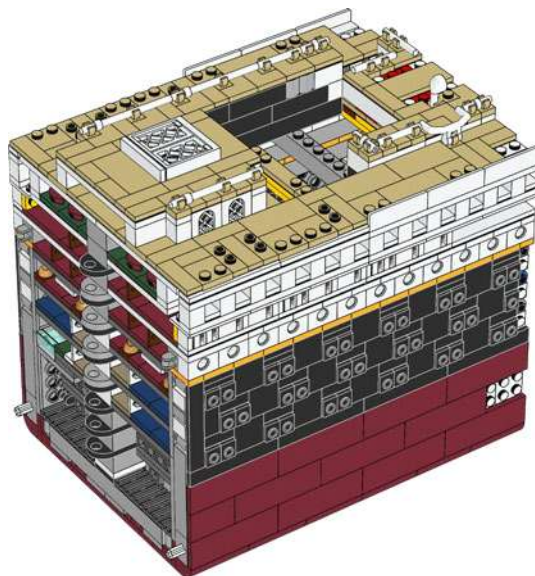
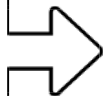

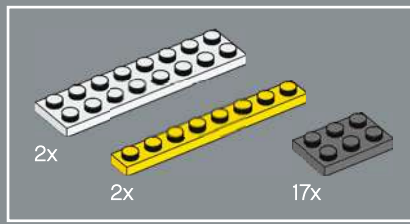

105

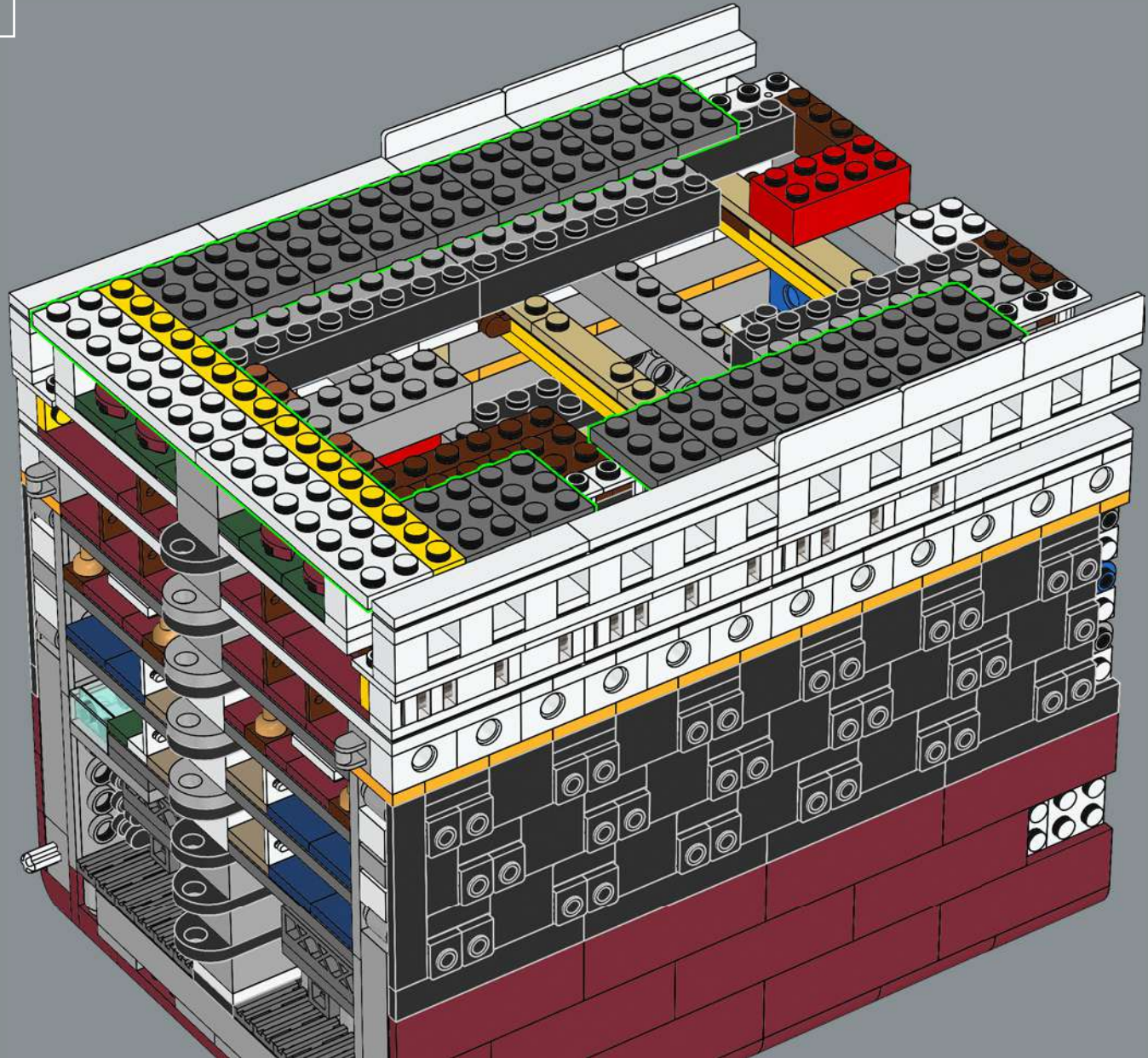

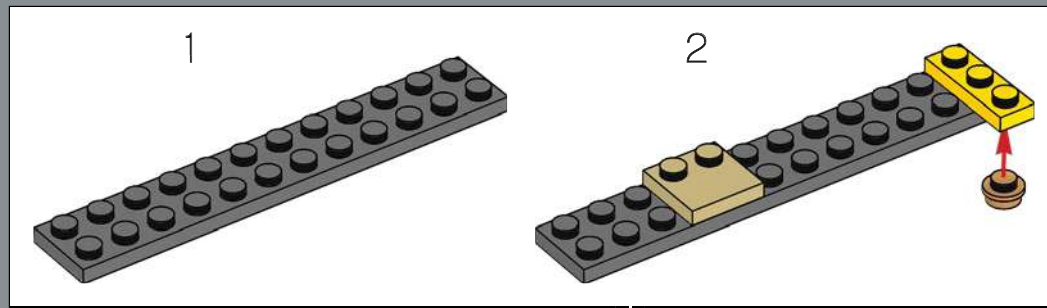
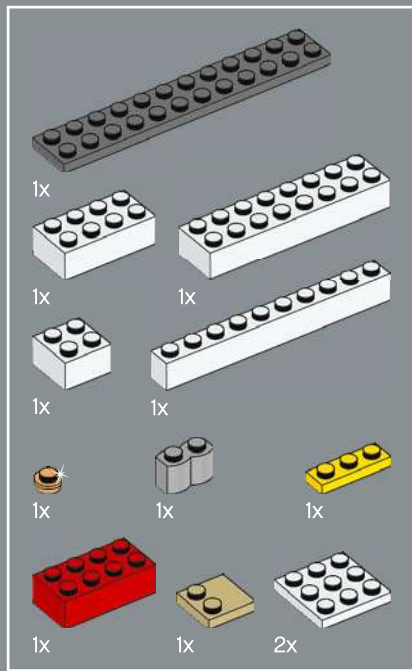

106

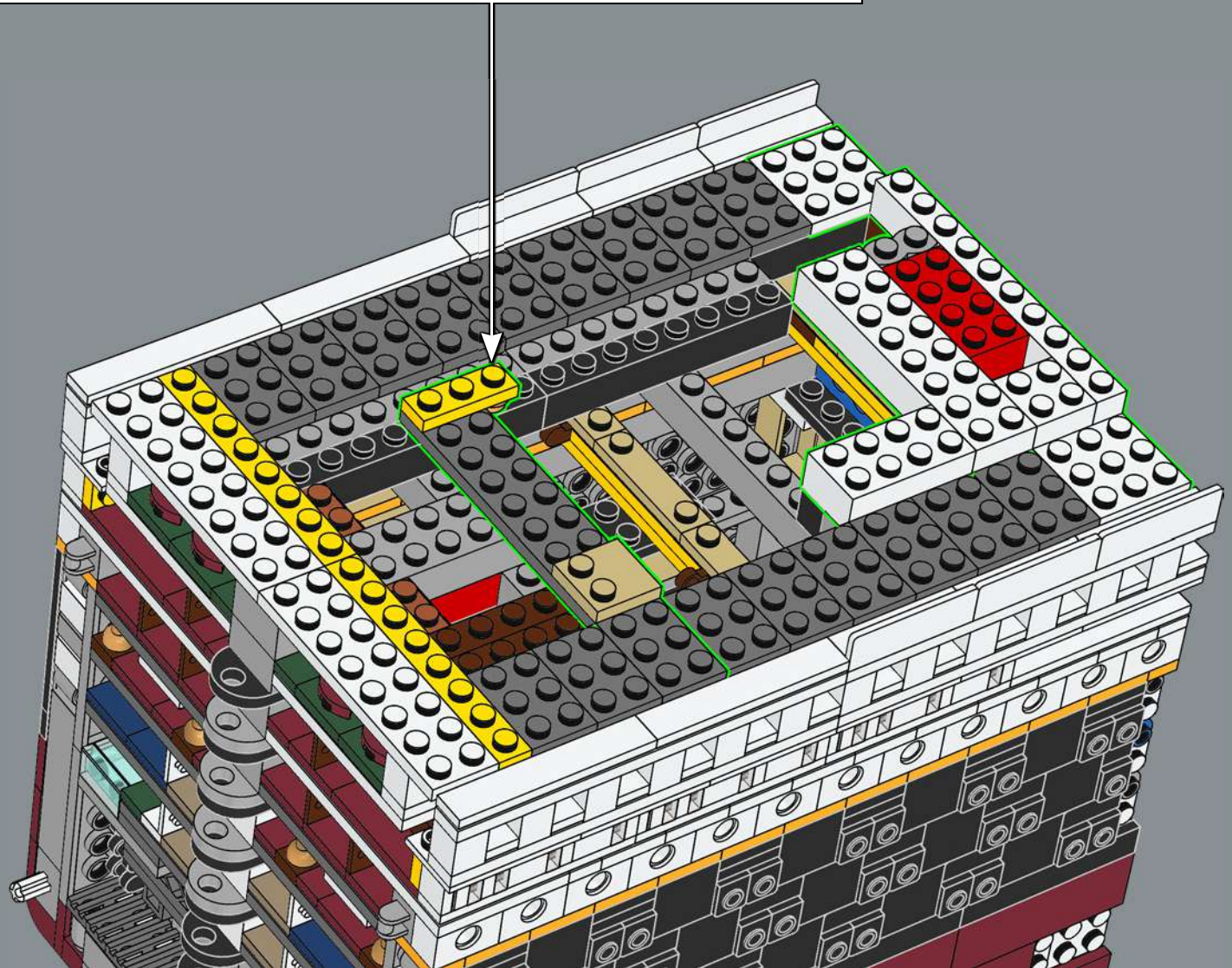

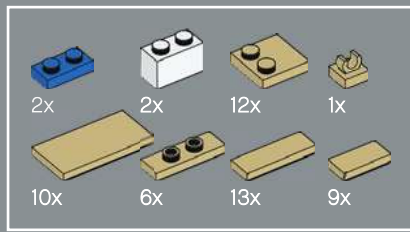

107

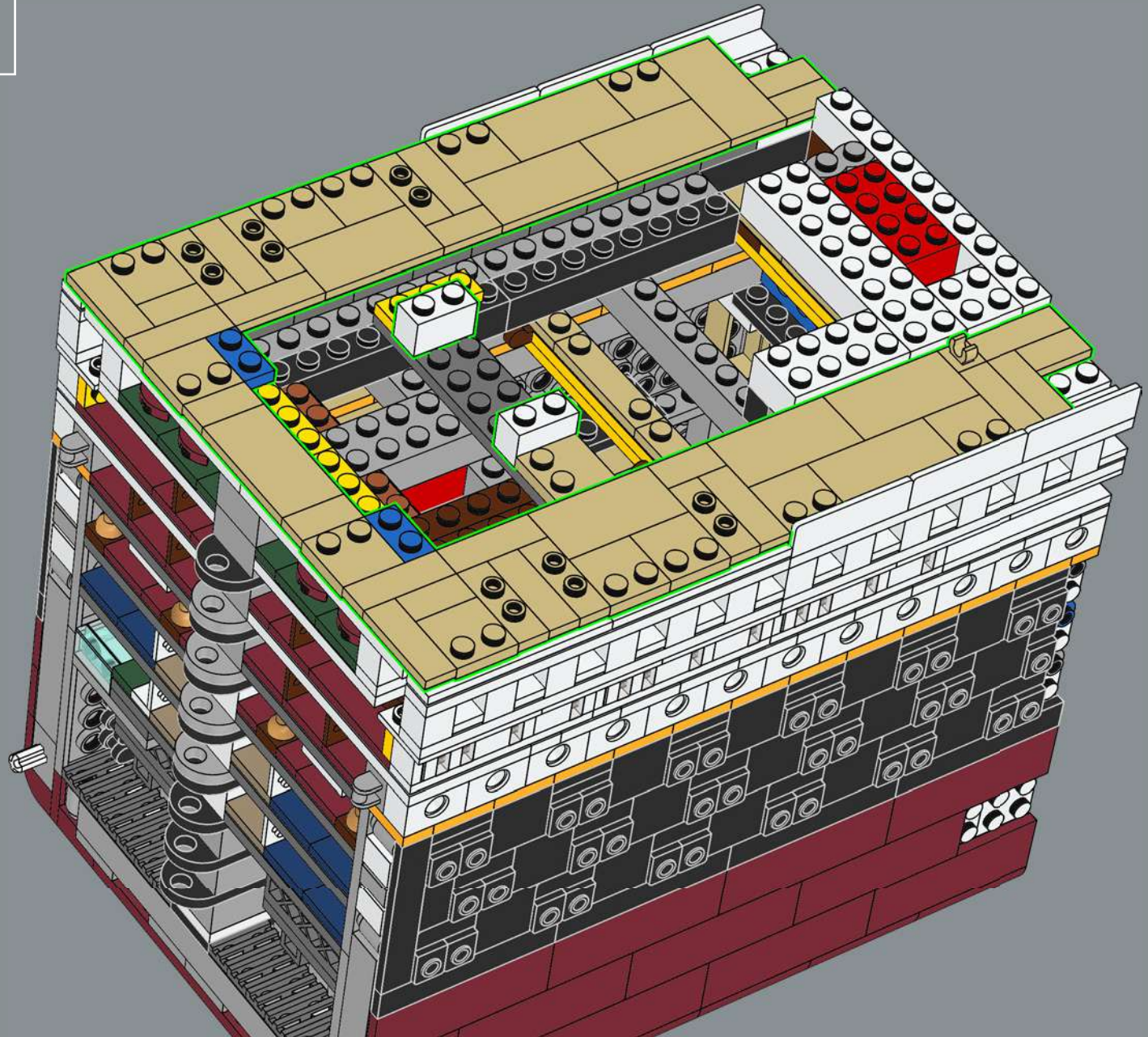

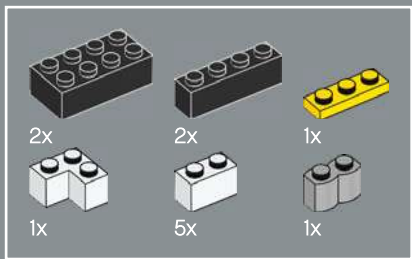

108

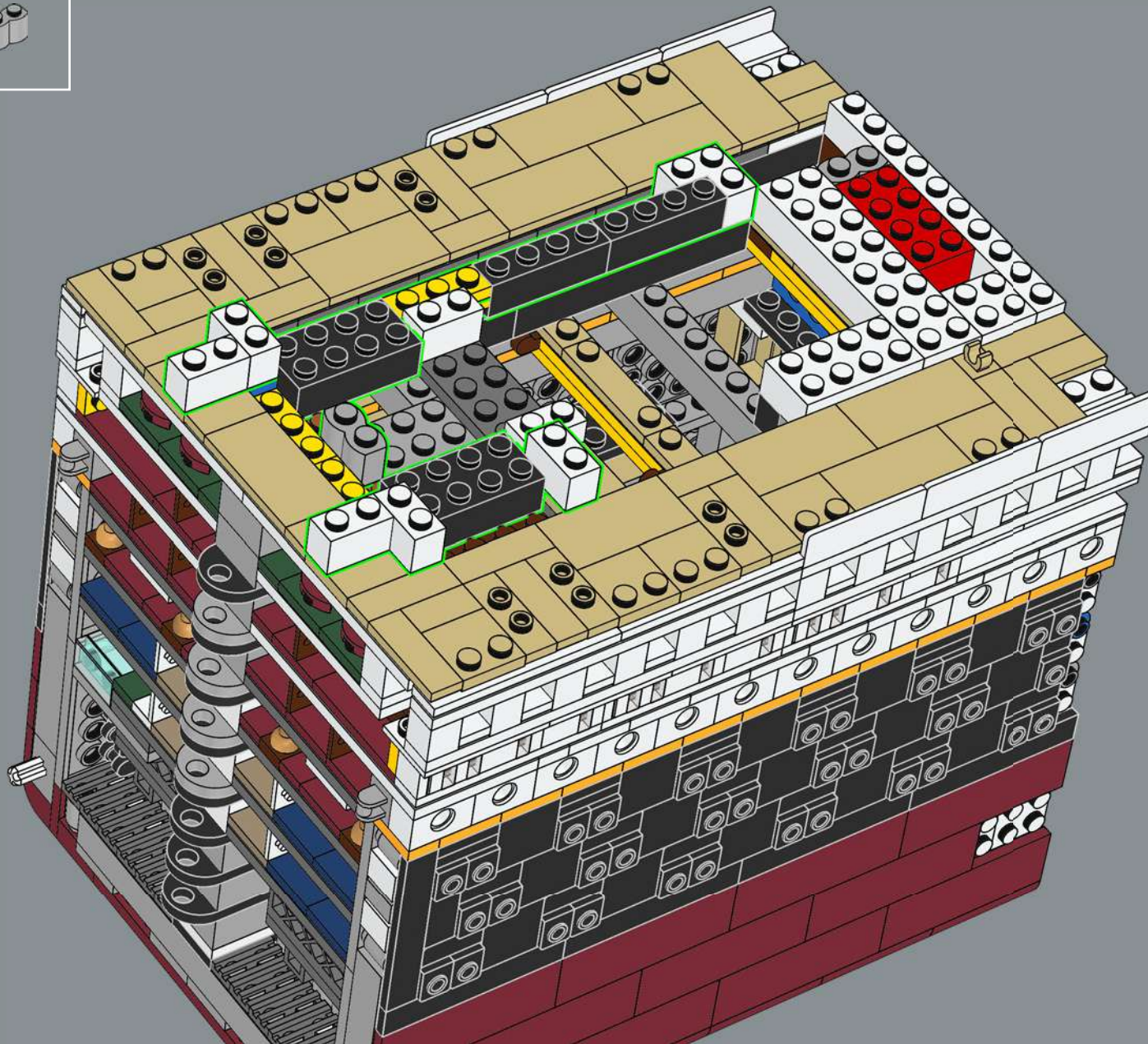

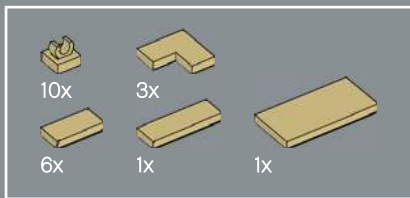

109

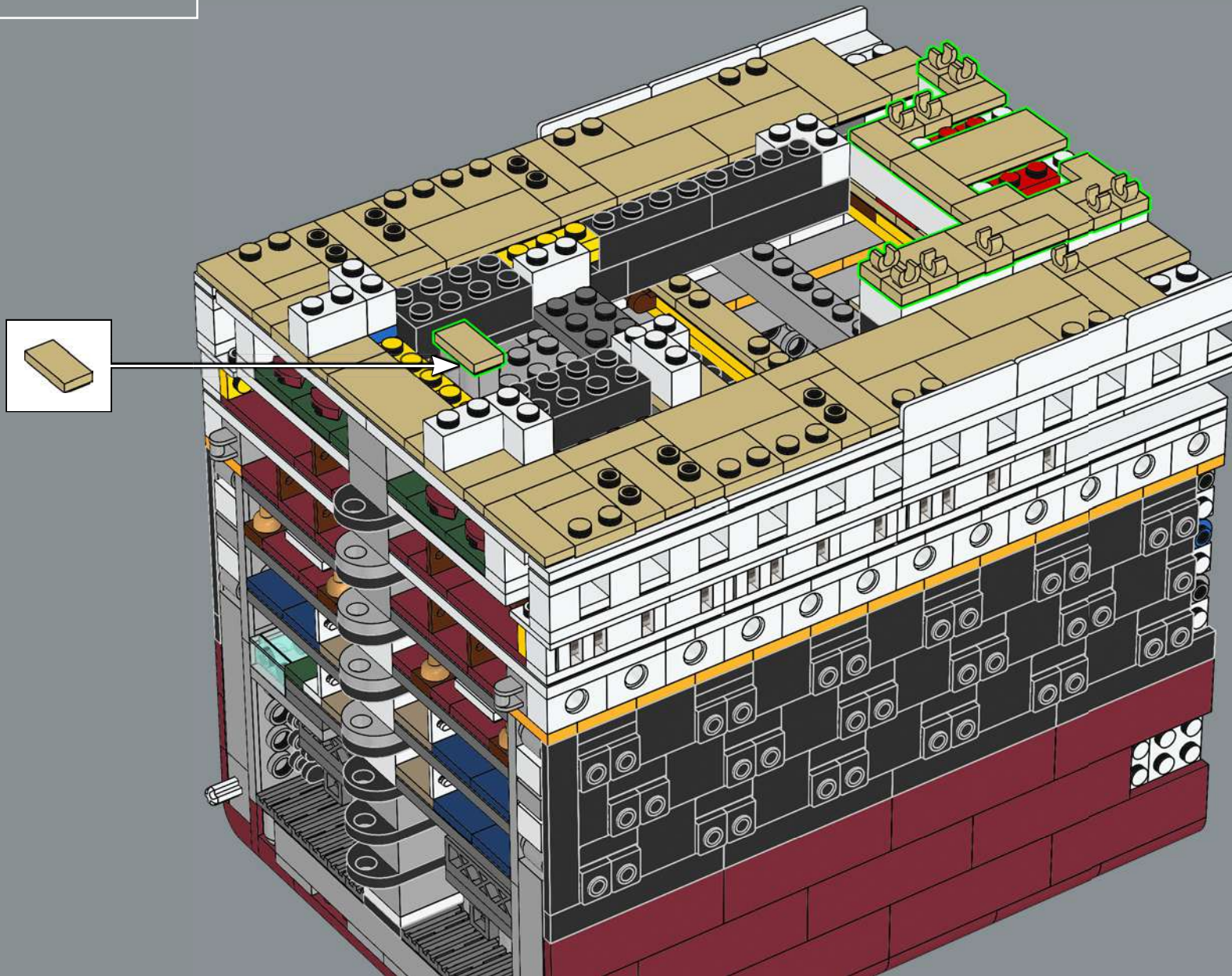

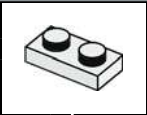
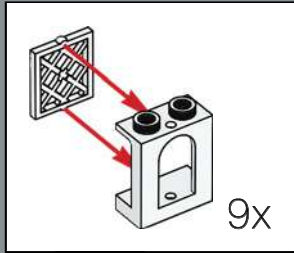
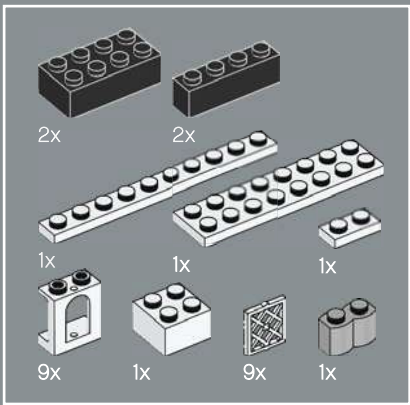

110

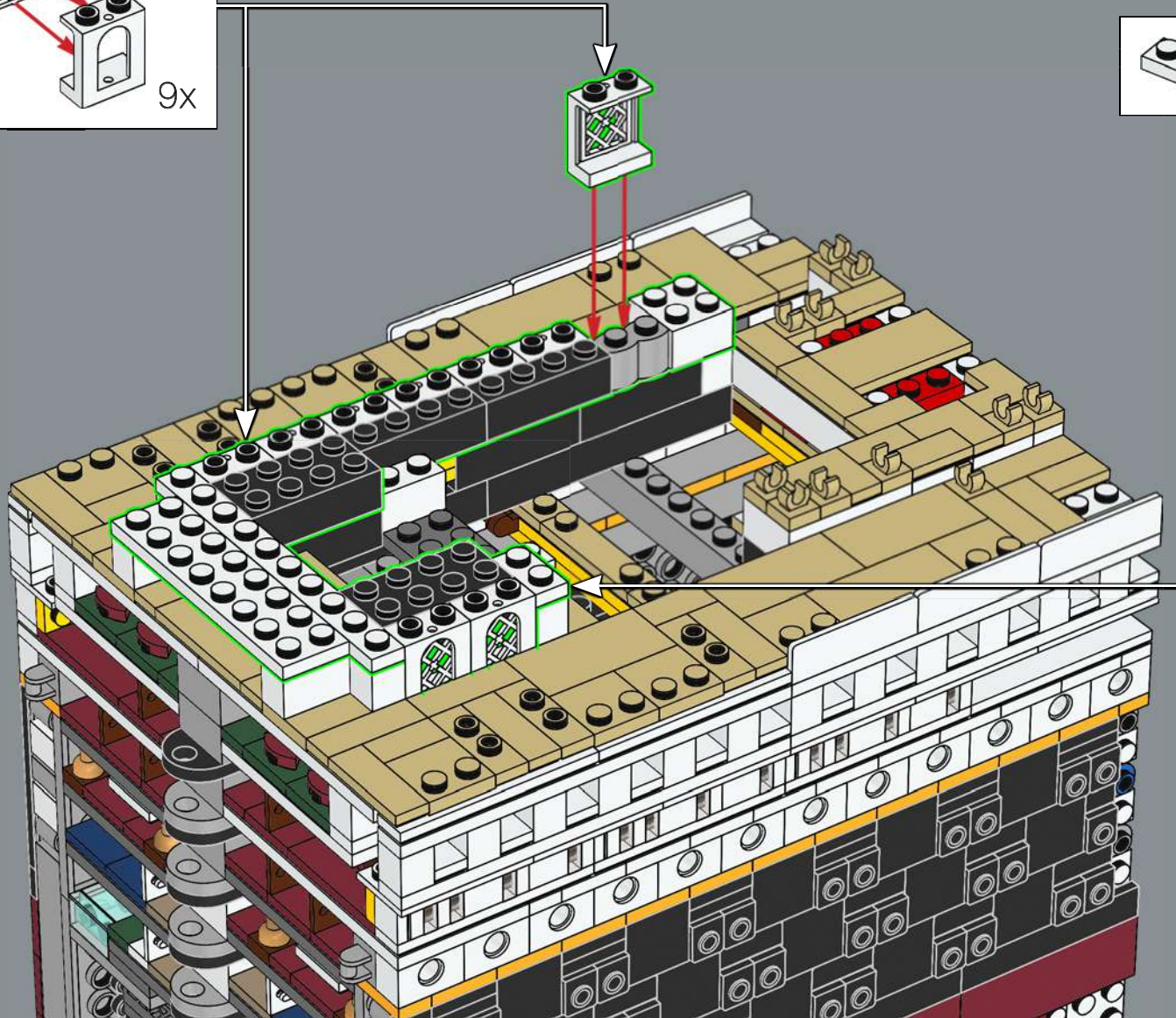

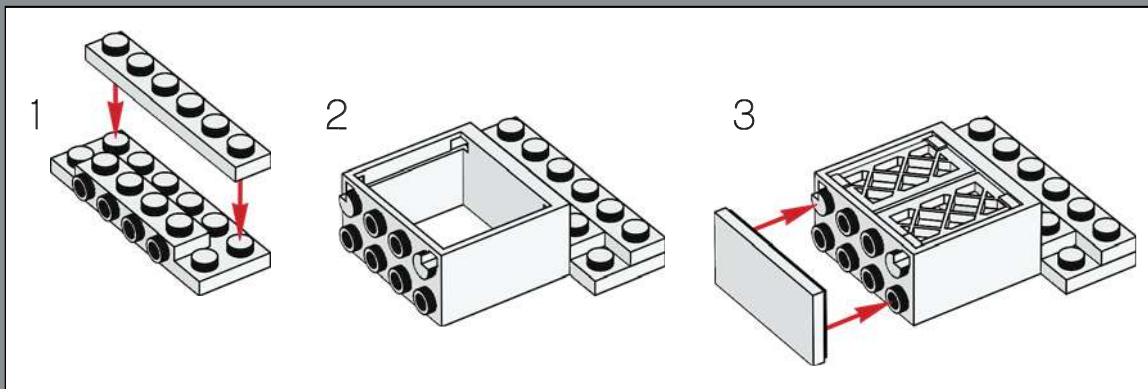
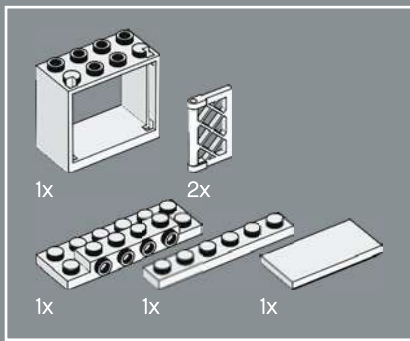

111

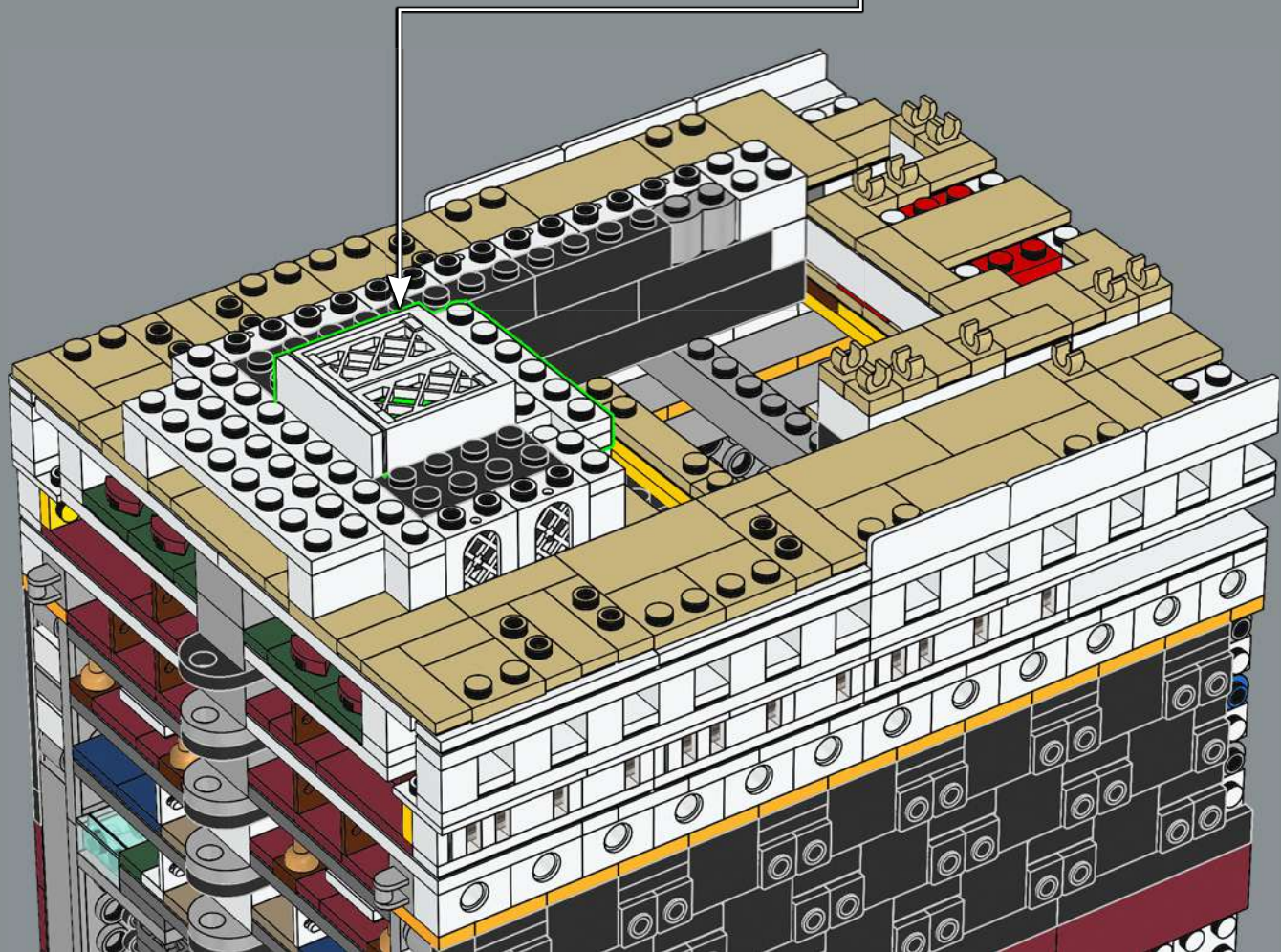

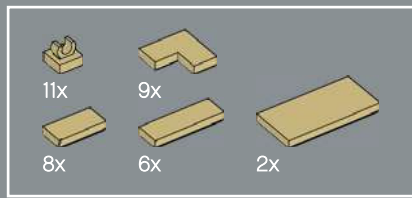

112

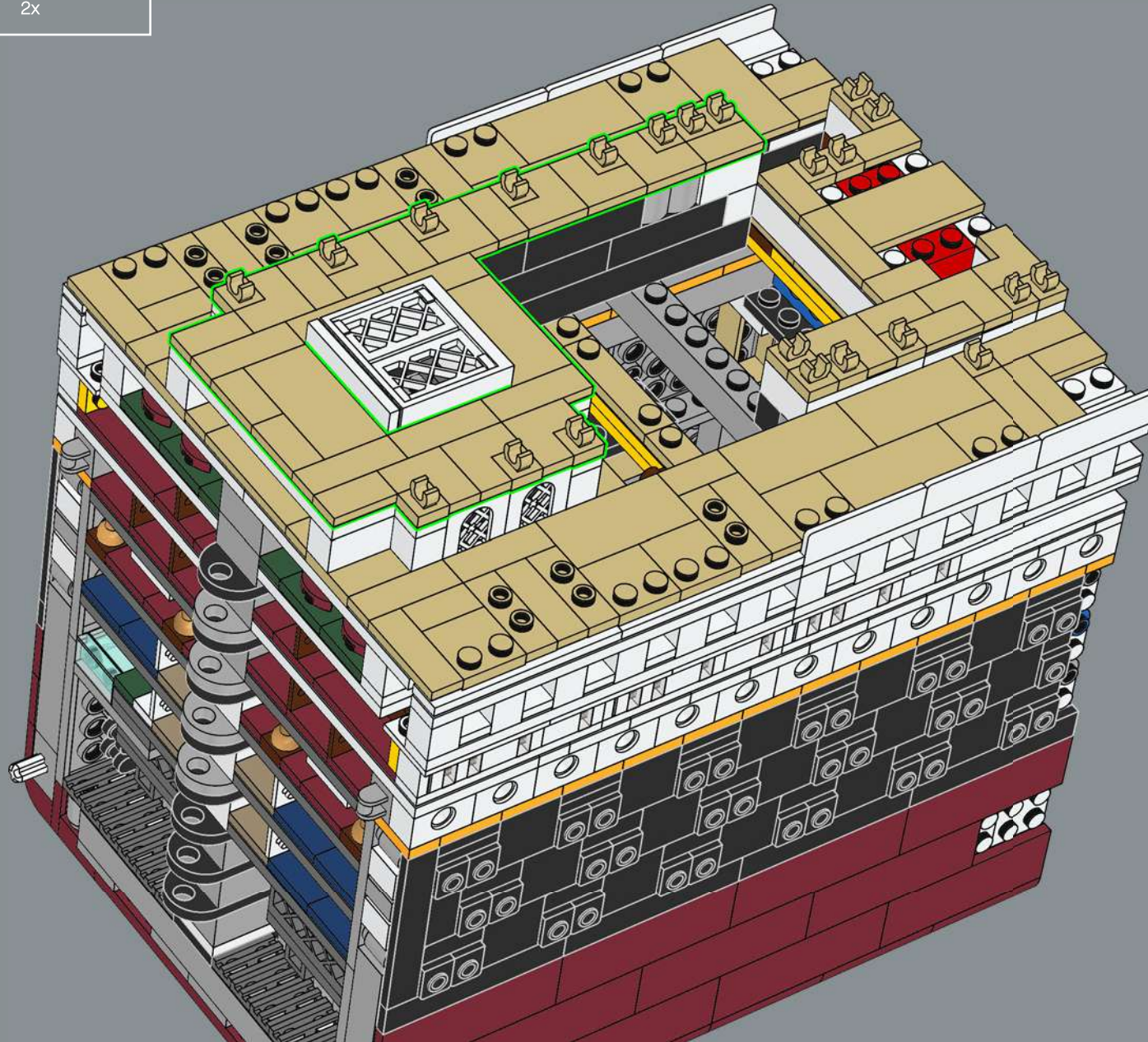

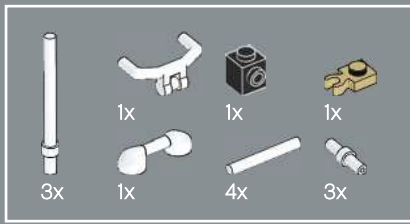

113

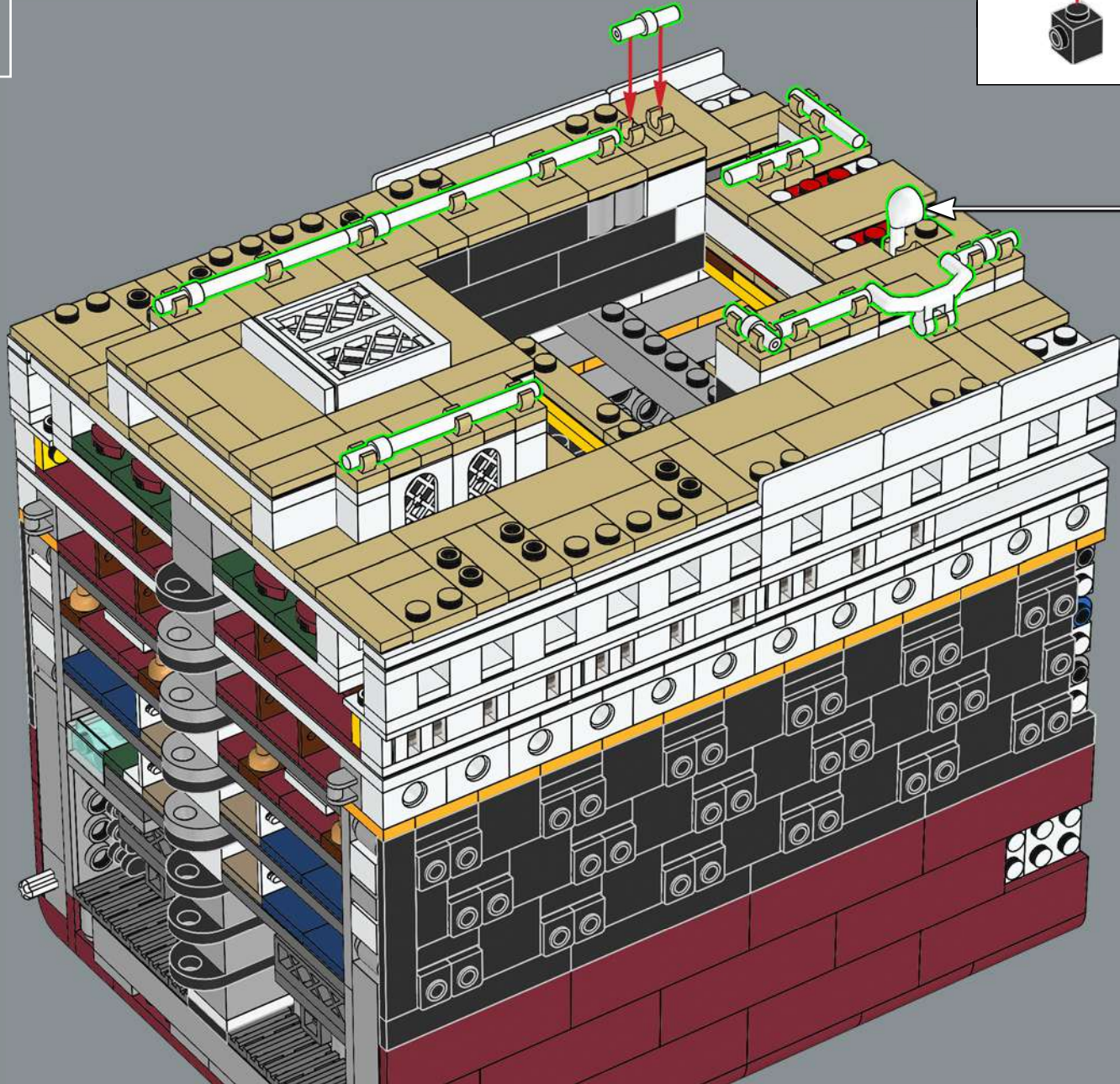
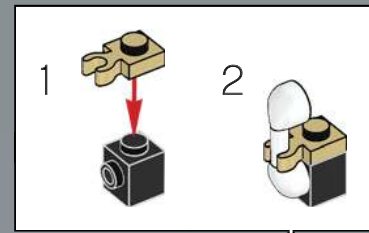

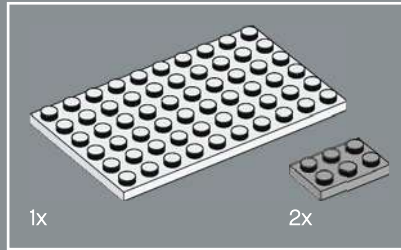
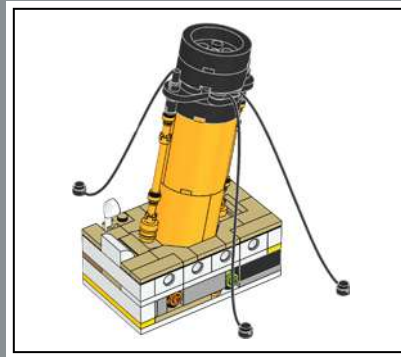
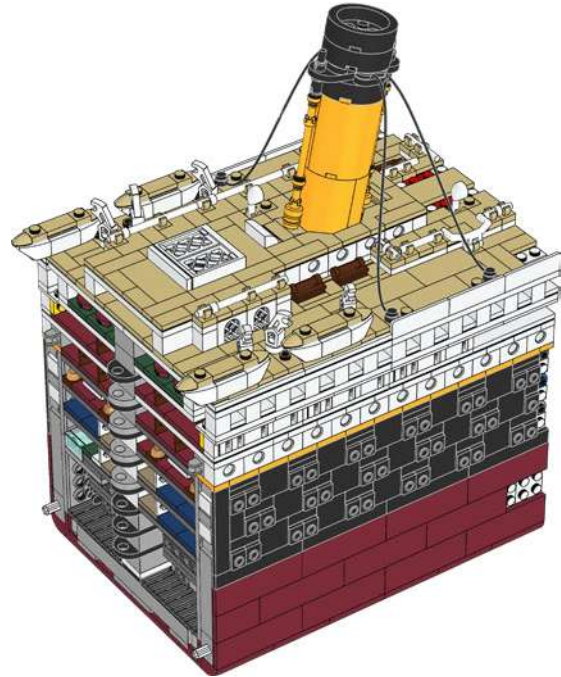
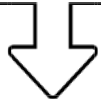

114

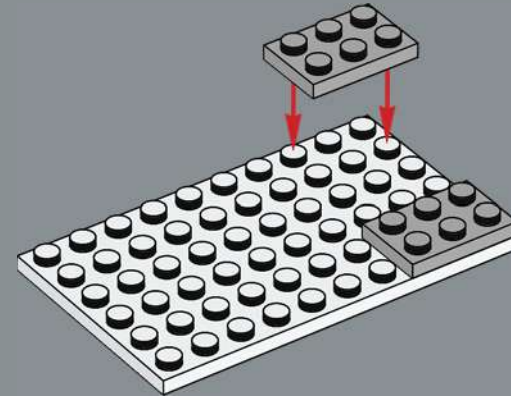

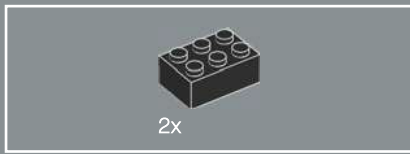

115

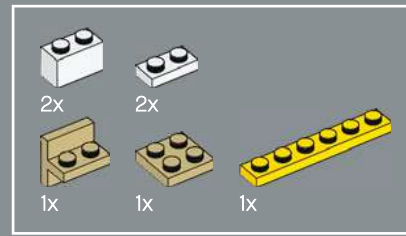
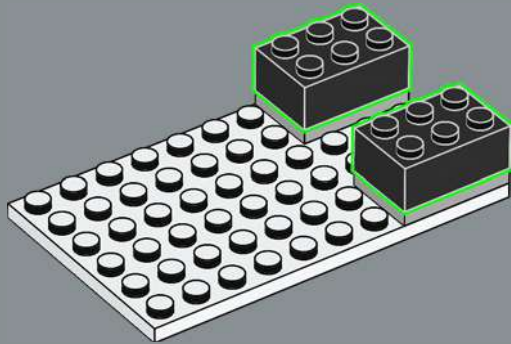

116

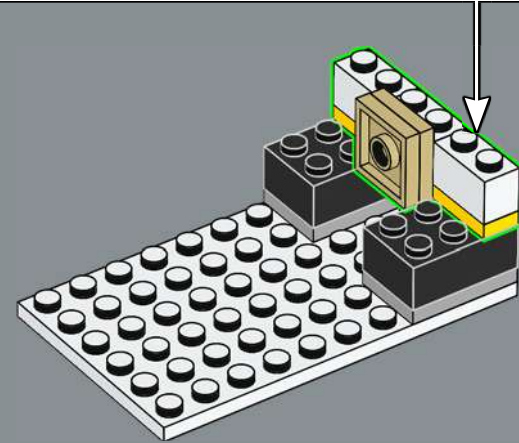
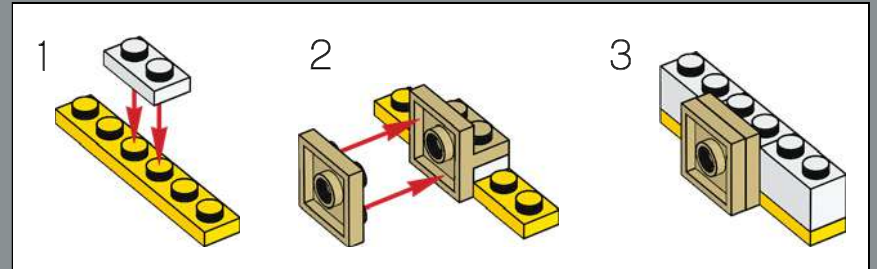

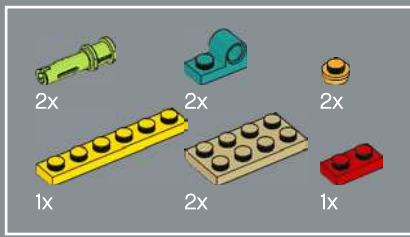

117

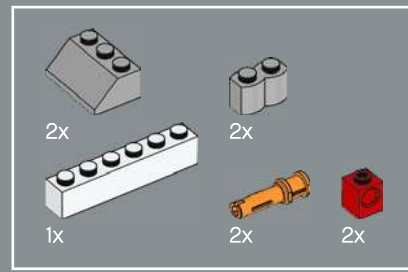
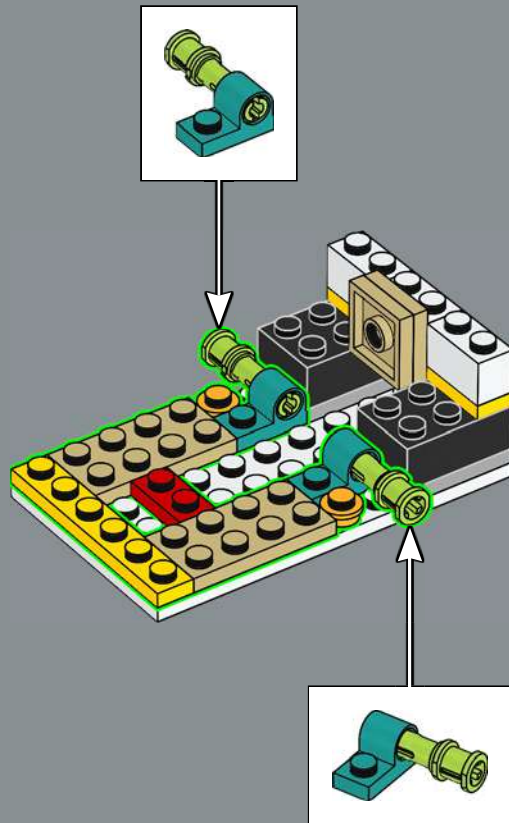

118

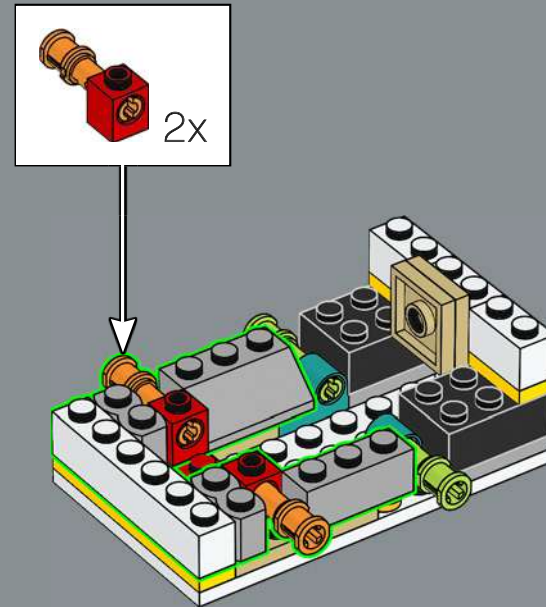

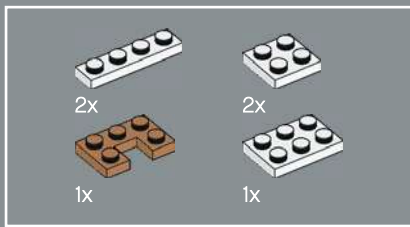

119

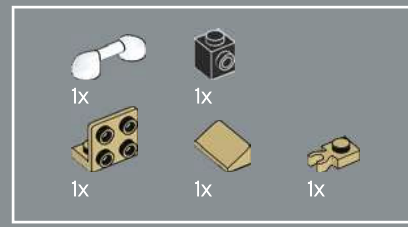
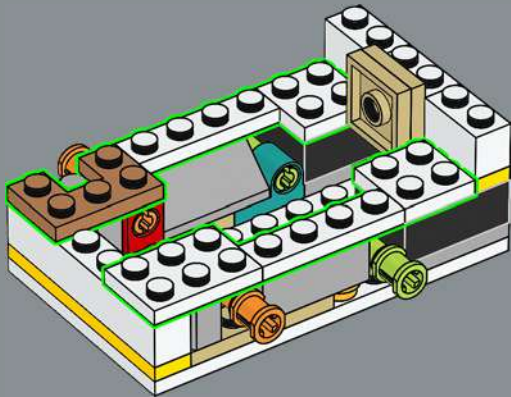

120

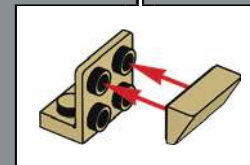
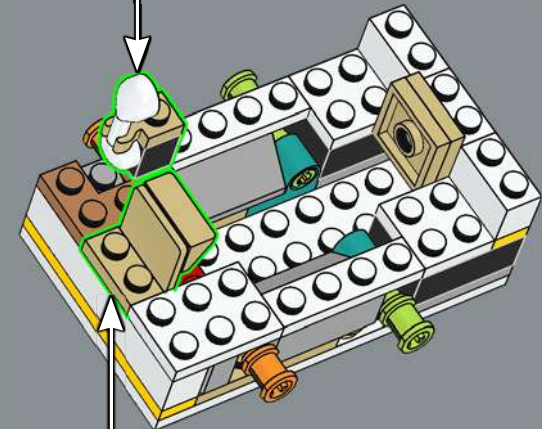
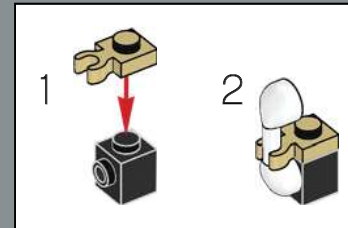

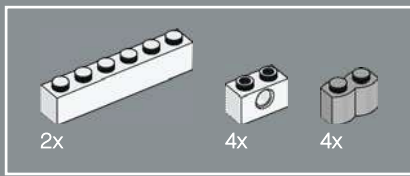

121

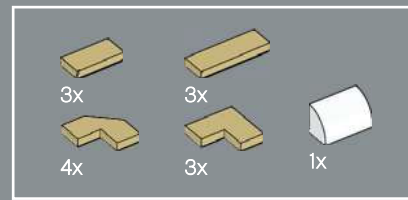
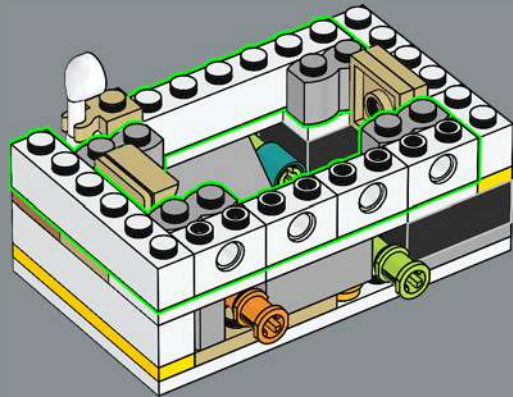

122

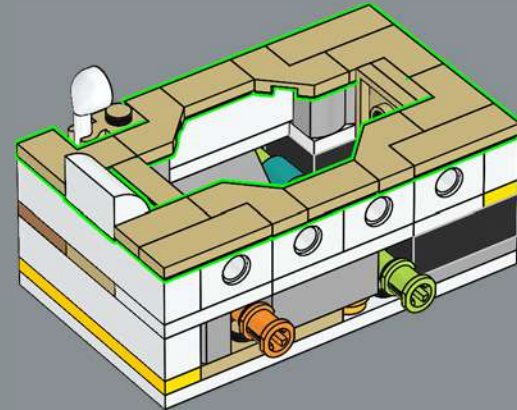

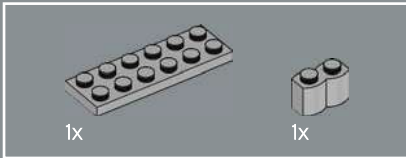
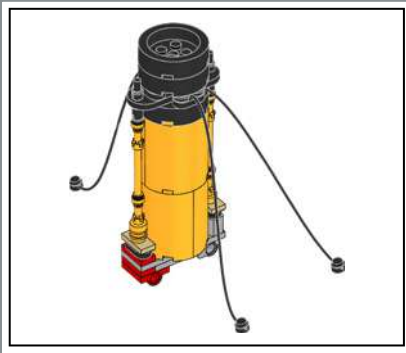

123

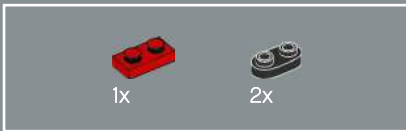
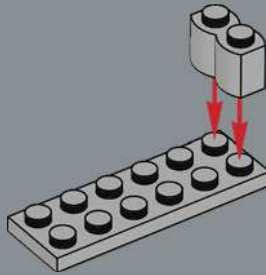

124

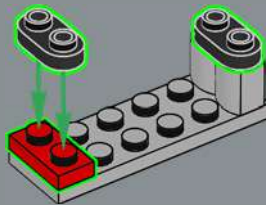

125

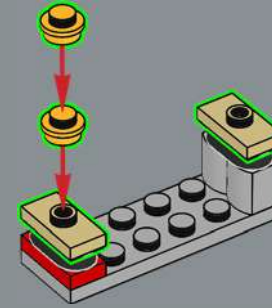

126

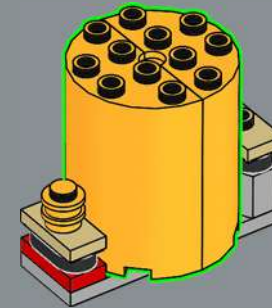

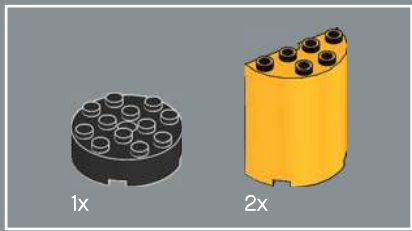

127

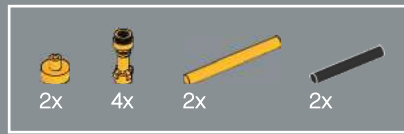
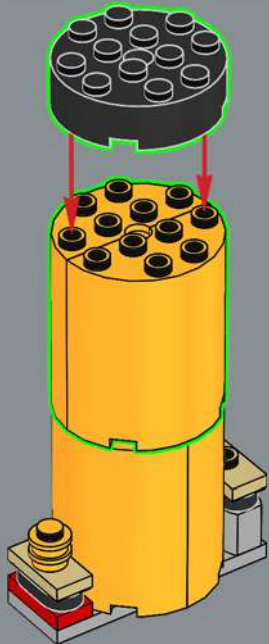

128

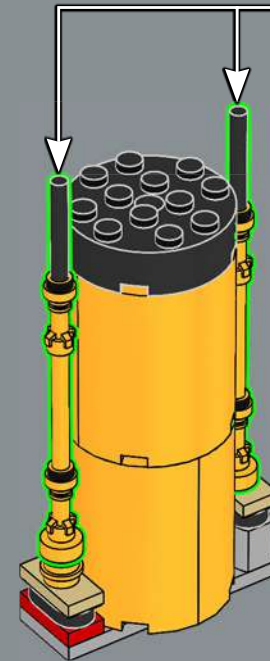
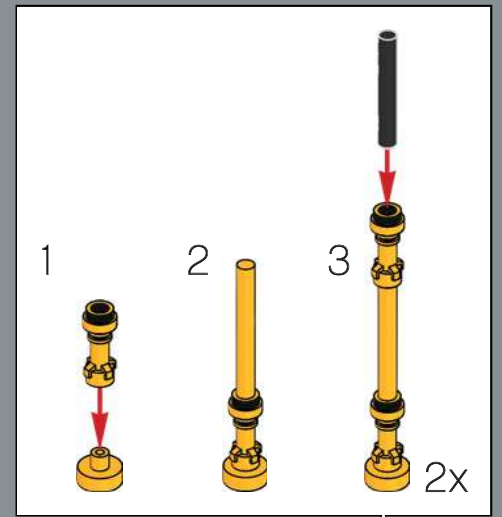



129

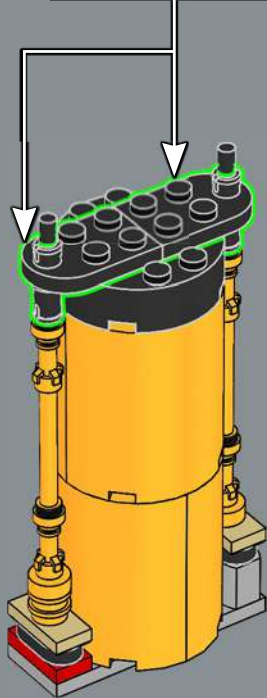
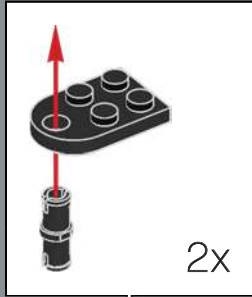

130

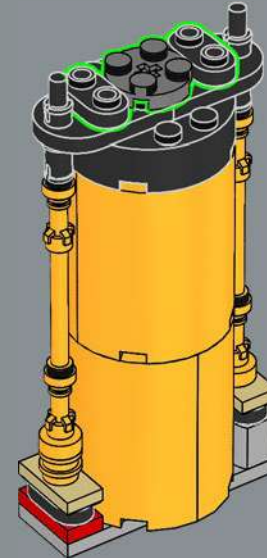

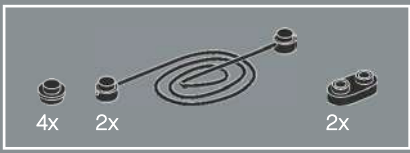

131

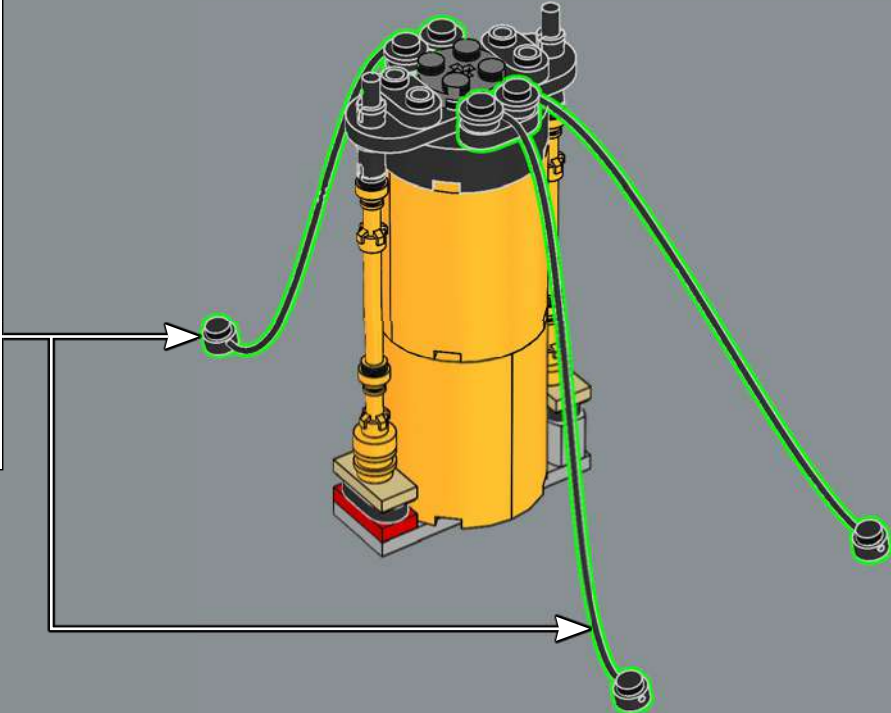
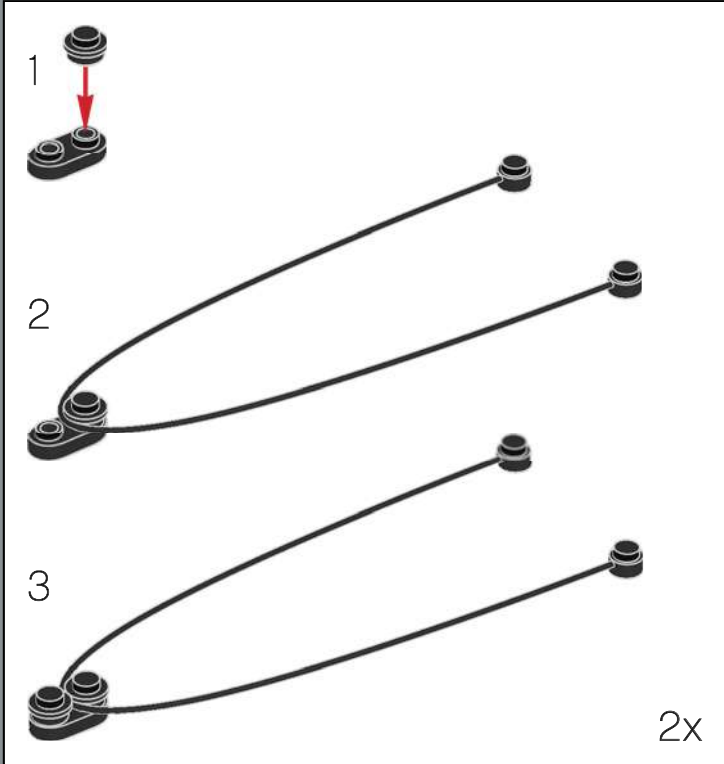

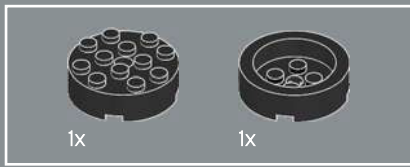

132

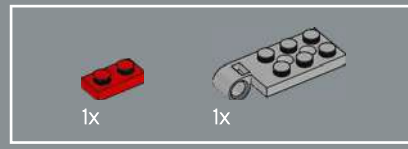
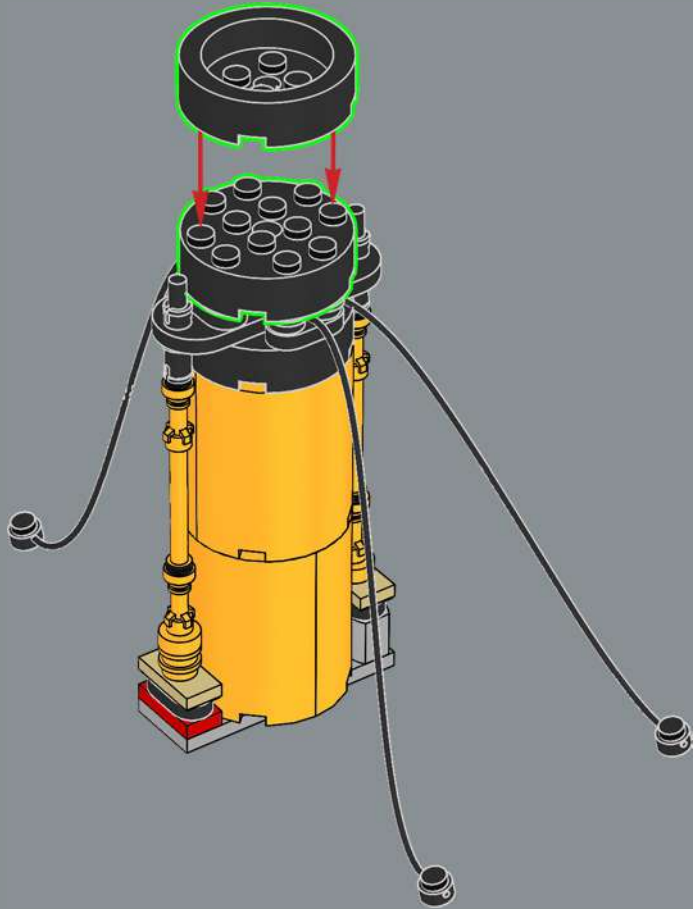

133

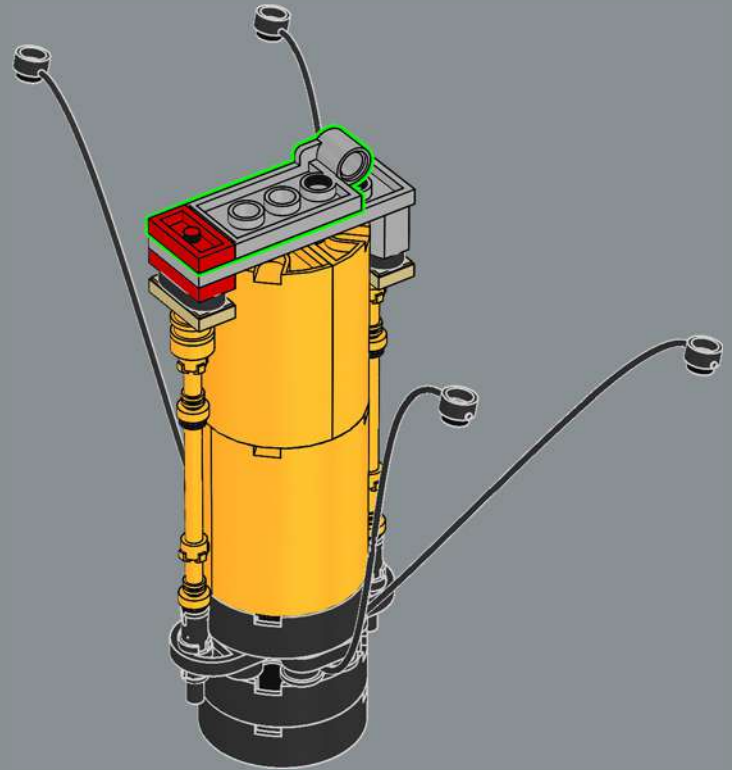

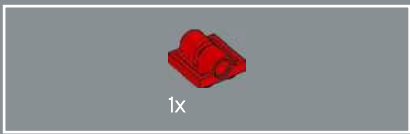

134

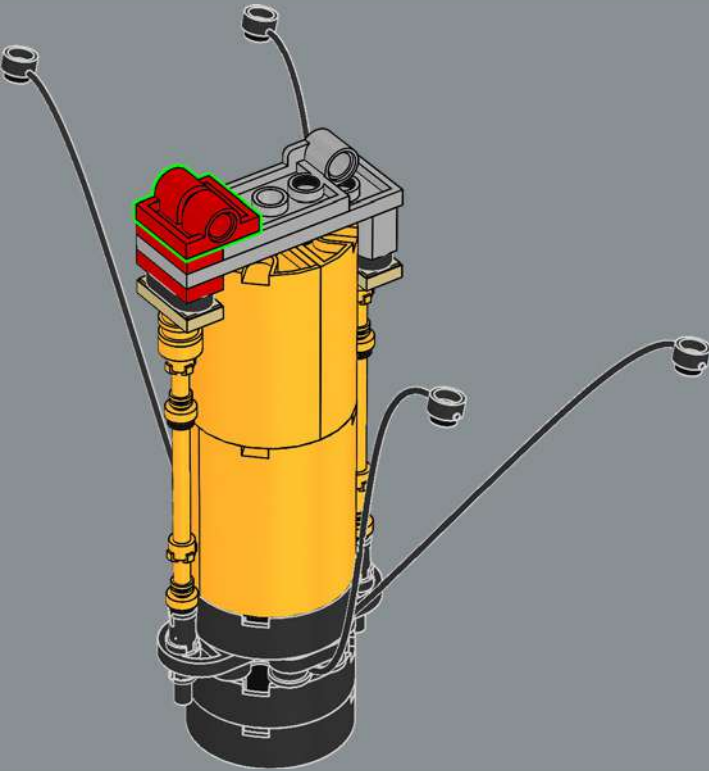

135

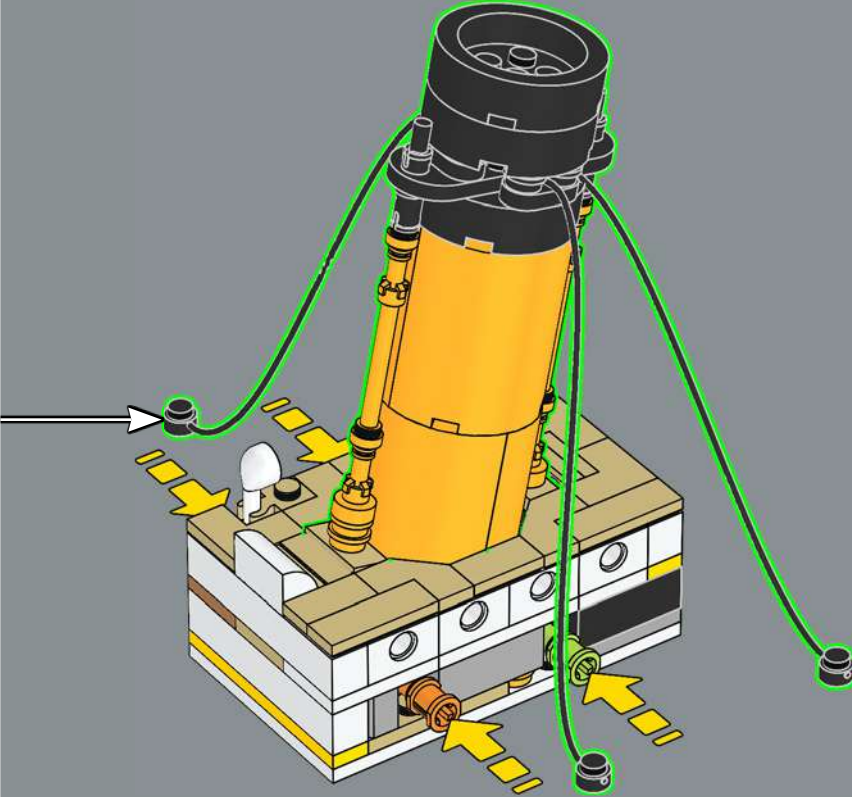

136

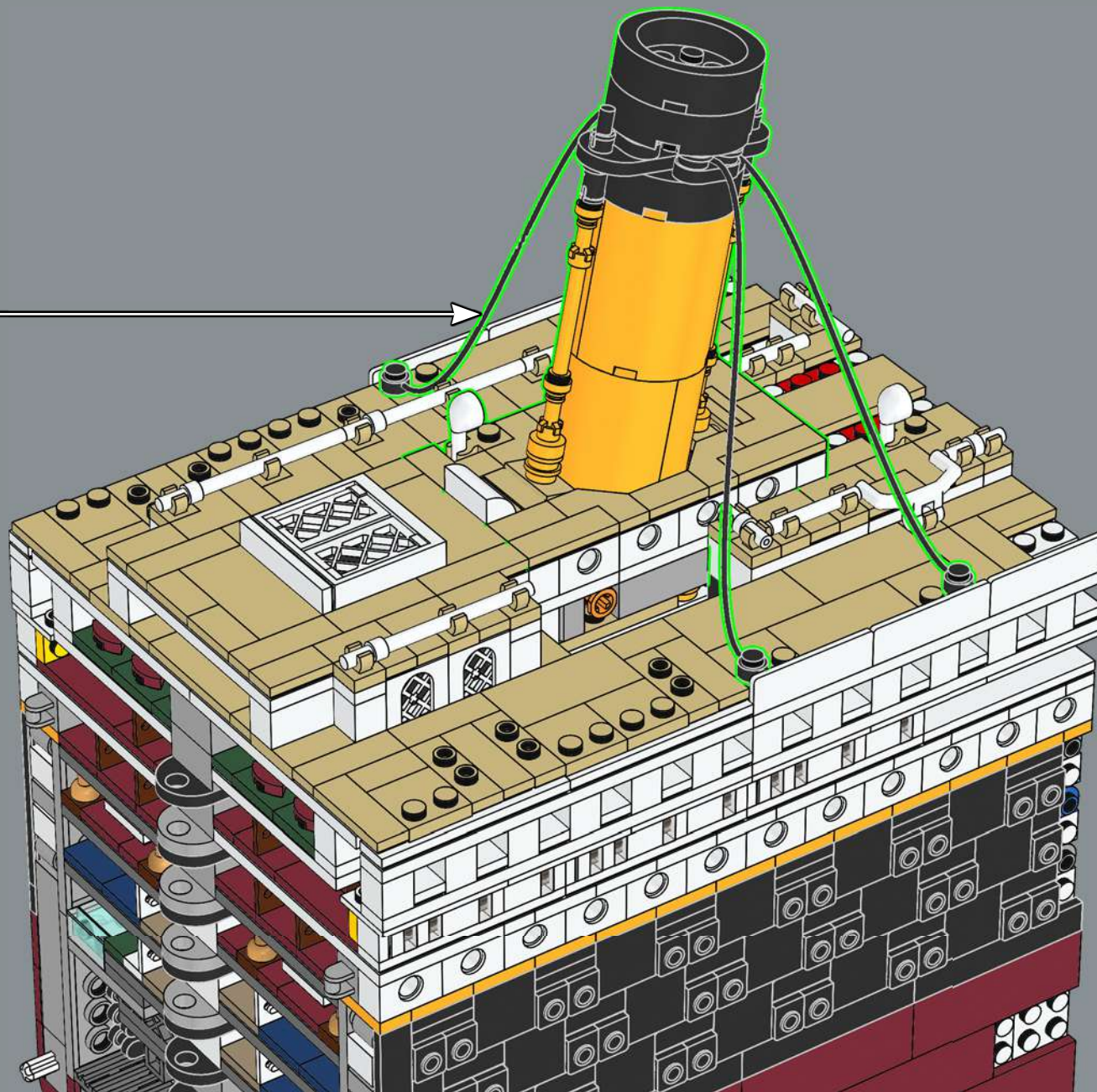

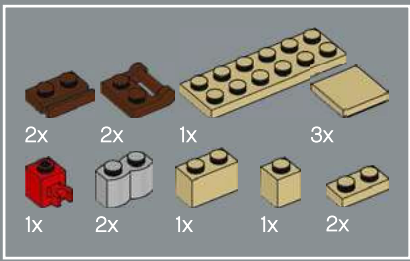

137

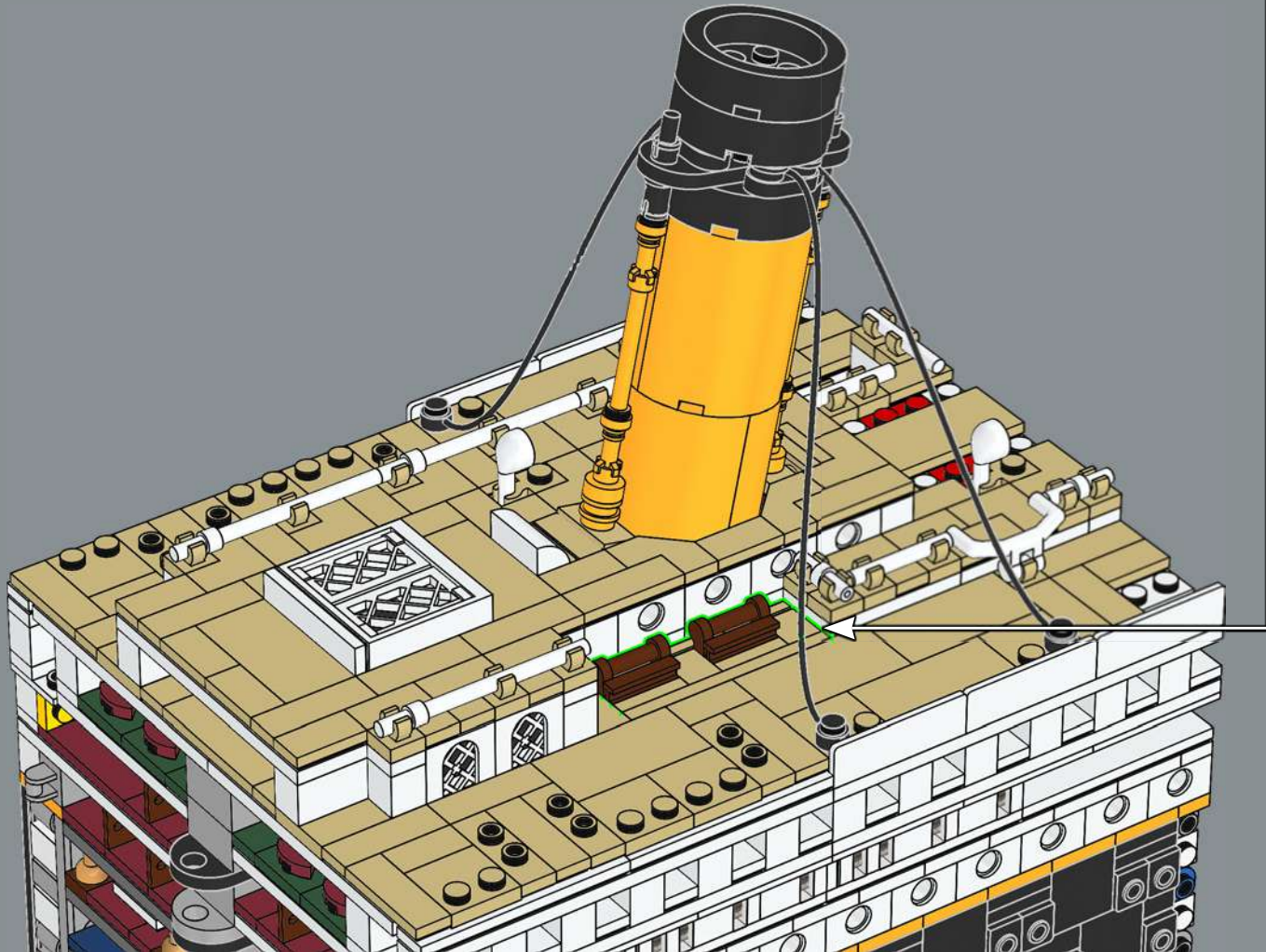
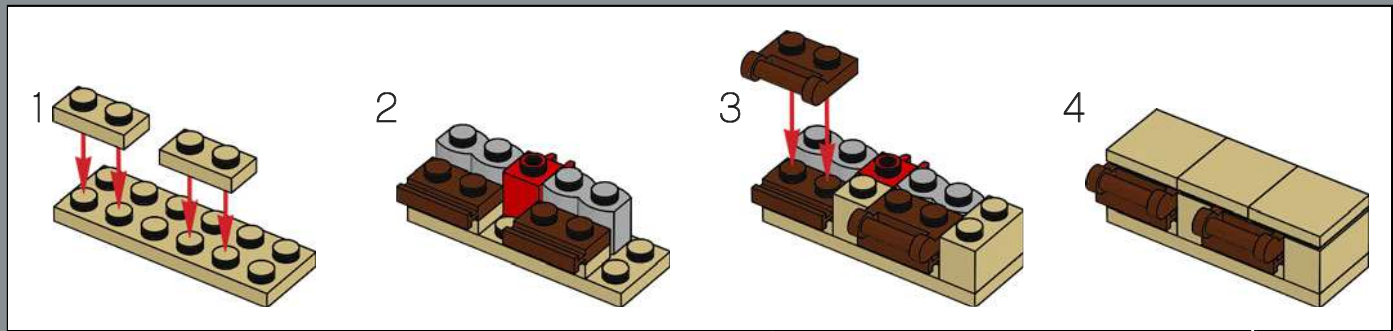

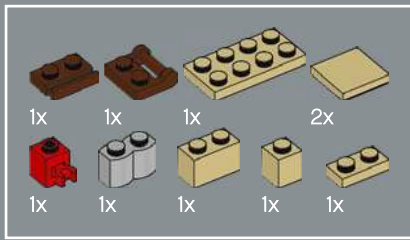

138

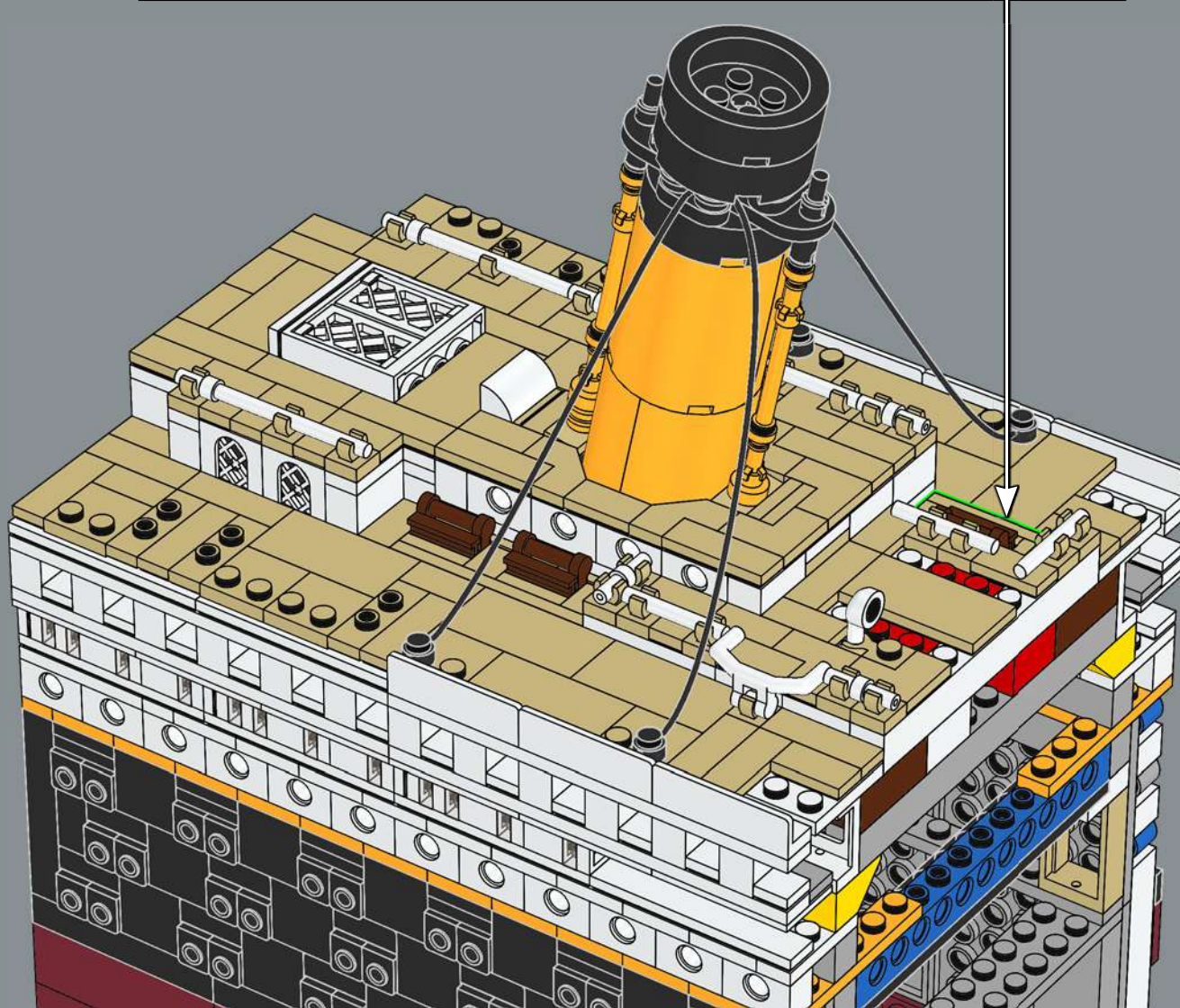
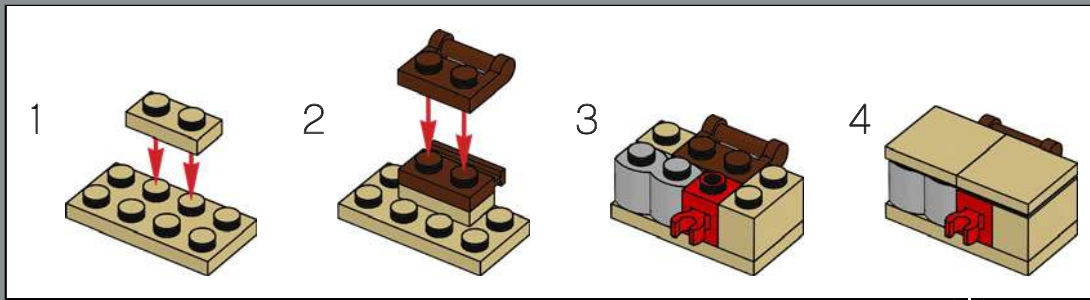

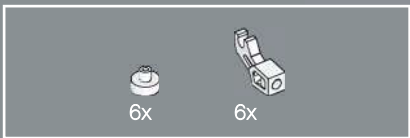

139

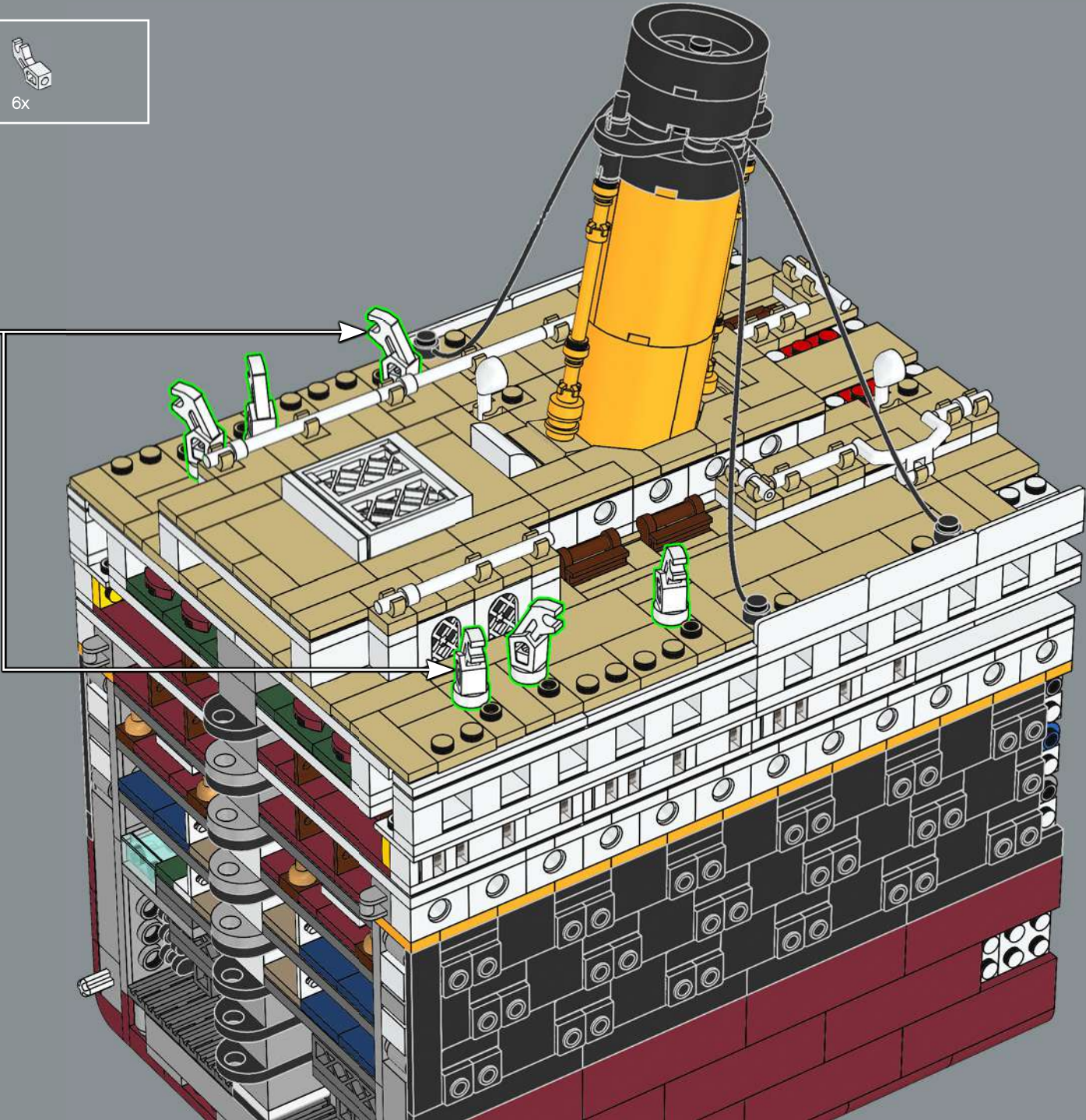
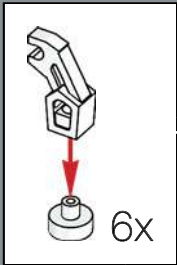

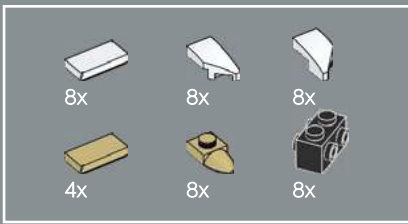

140

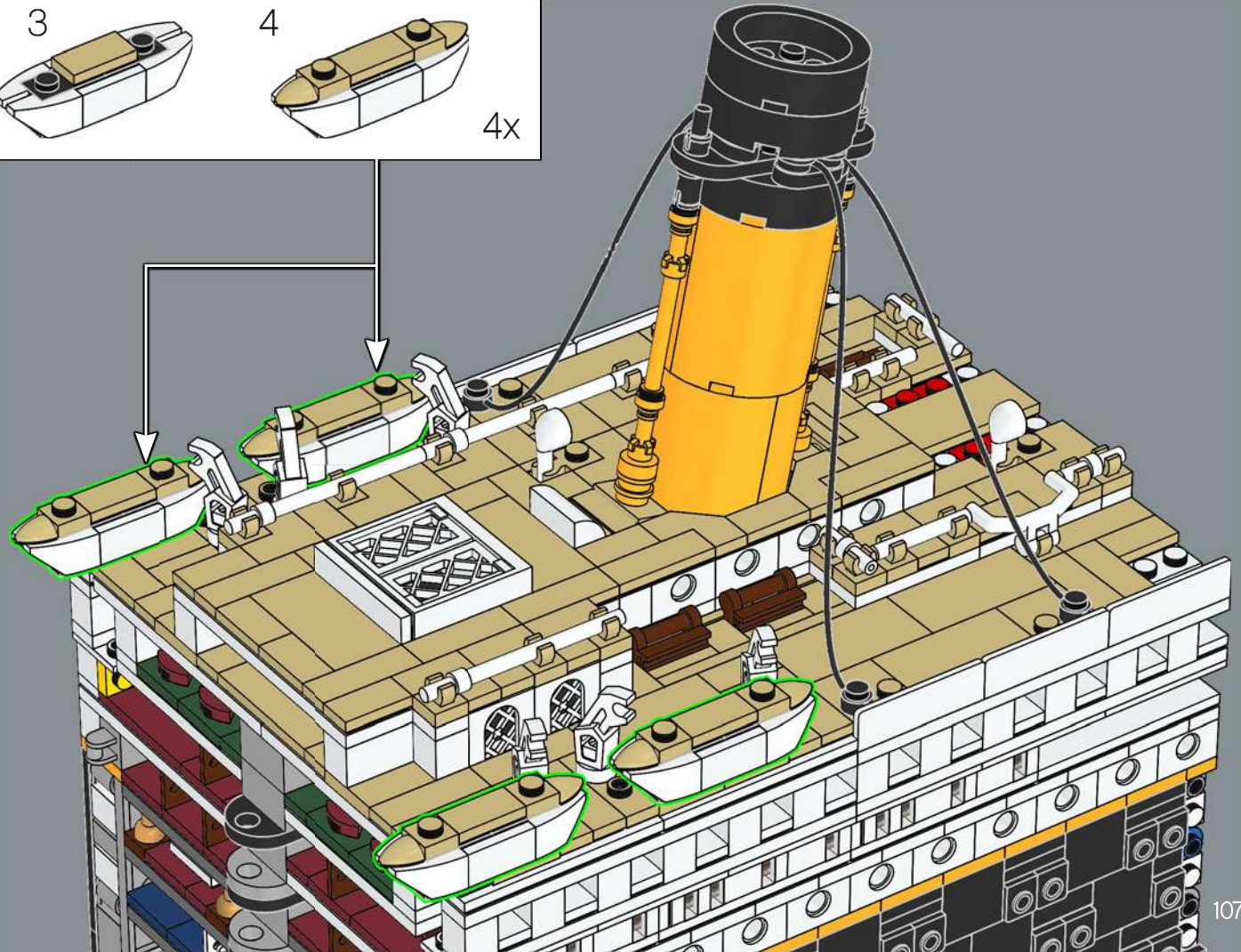
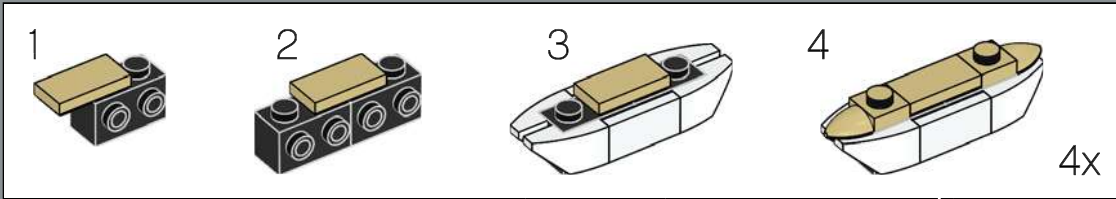

Of the 20 lifeboats onboard, 14 were standard wooden lifeboats with a capacity of 65 people each and four "collapsible" boats holding 47 people in each.

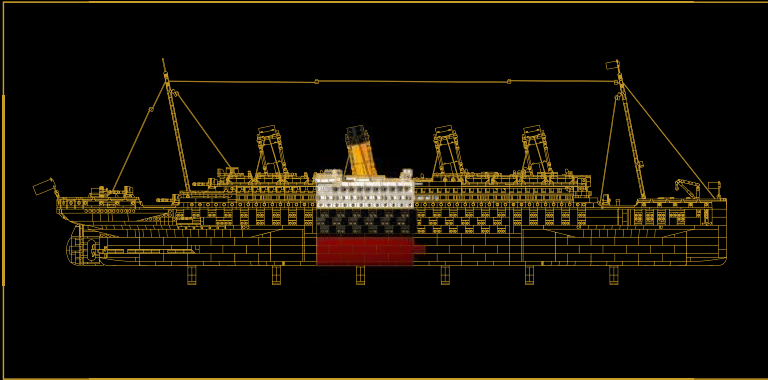

SECTION 4:

FUNNEL & COMPASS

This section includes a portion of the *Titanic's* massive engine rooms and the elevated structure in the centre that housed the main compass. It was elevated to ensure the least amount of interference from the massive amount of iron in the ship's hull. There is also a small sub-assembly that represents a bench used by passengers enjoying the upper decks of the ship.



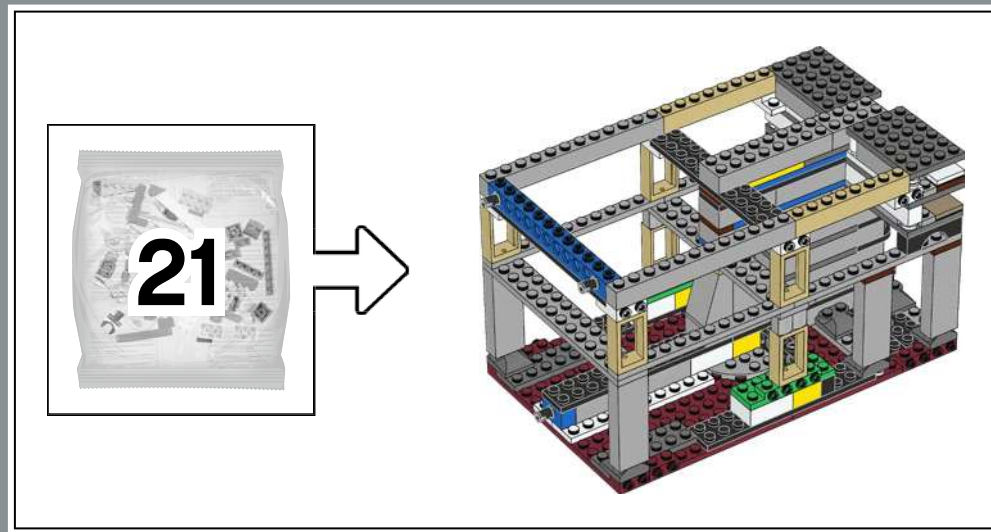

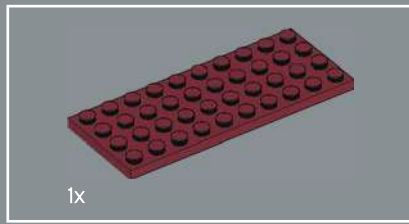
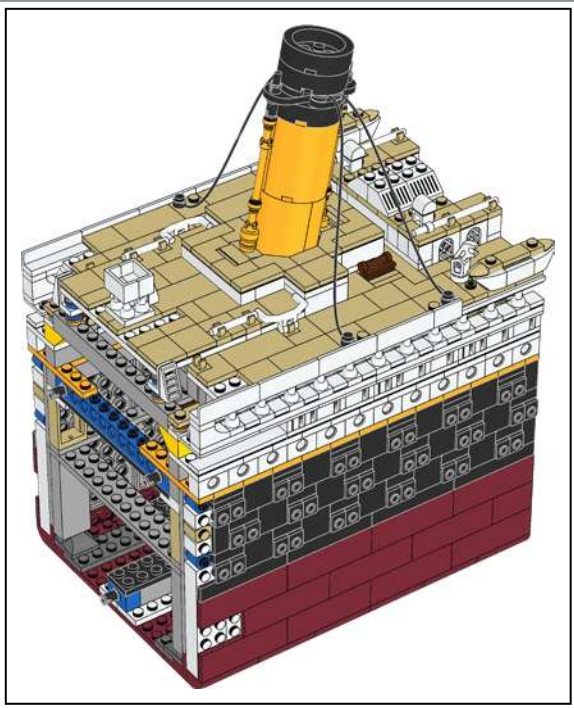

141

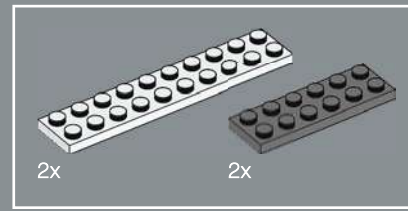
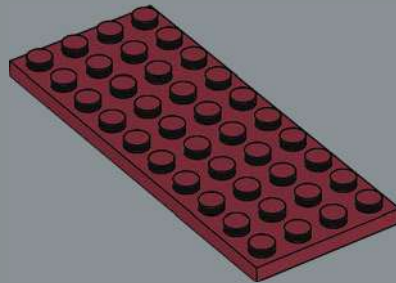

142

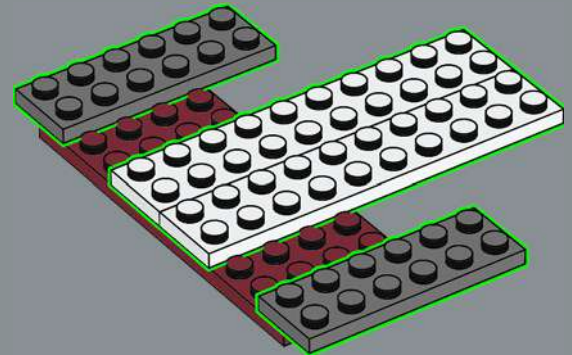

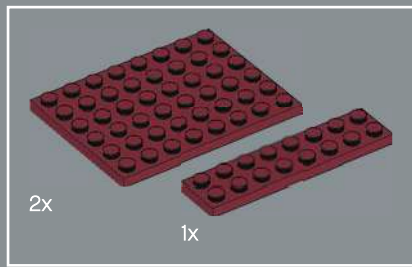

143

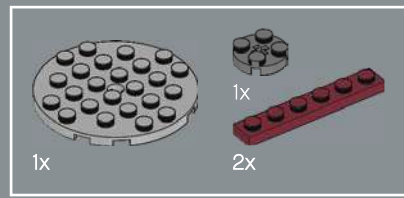
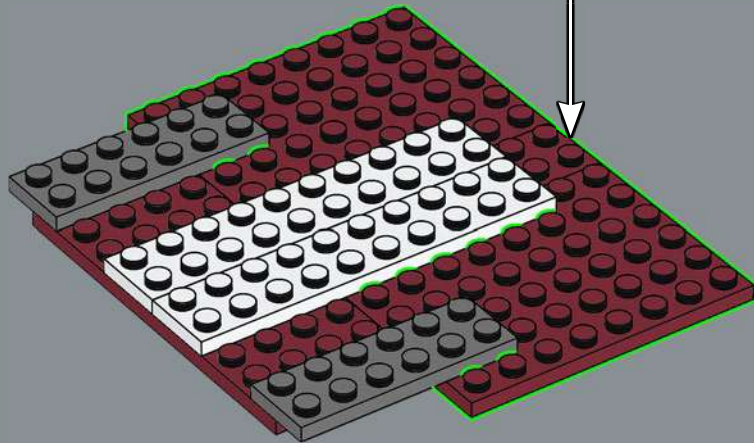
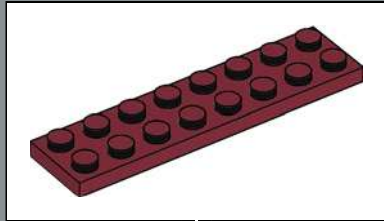

144

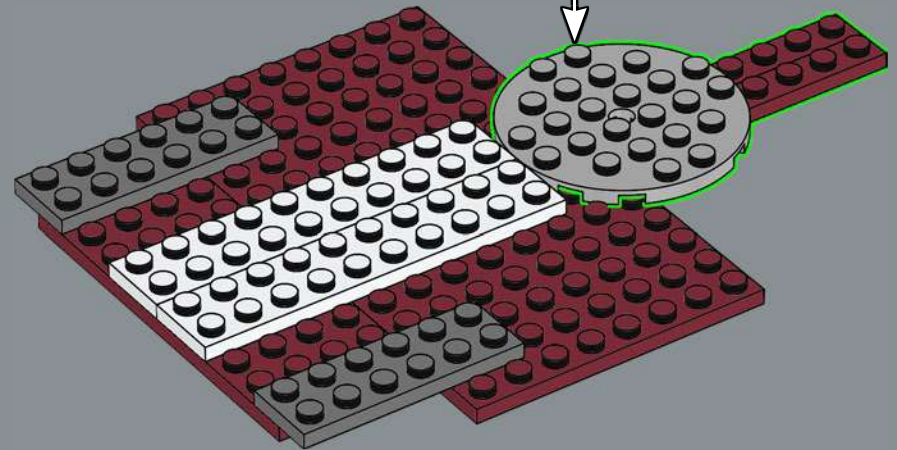
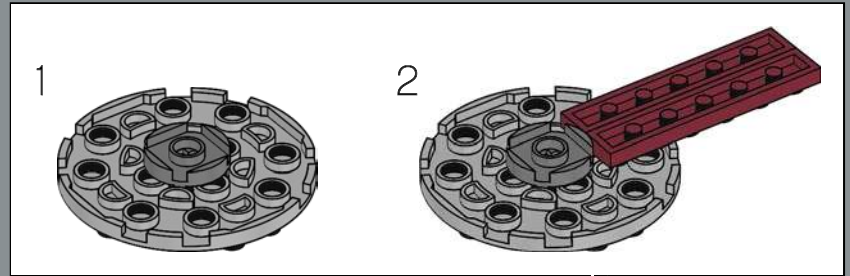

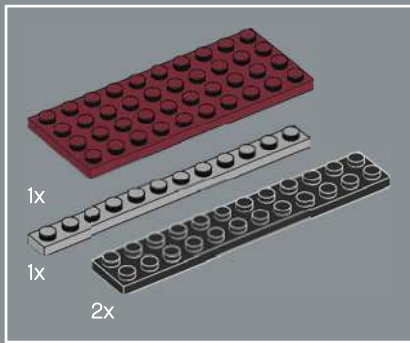

147

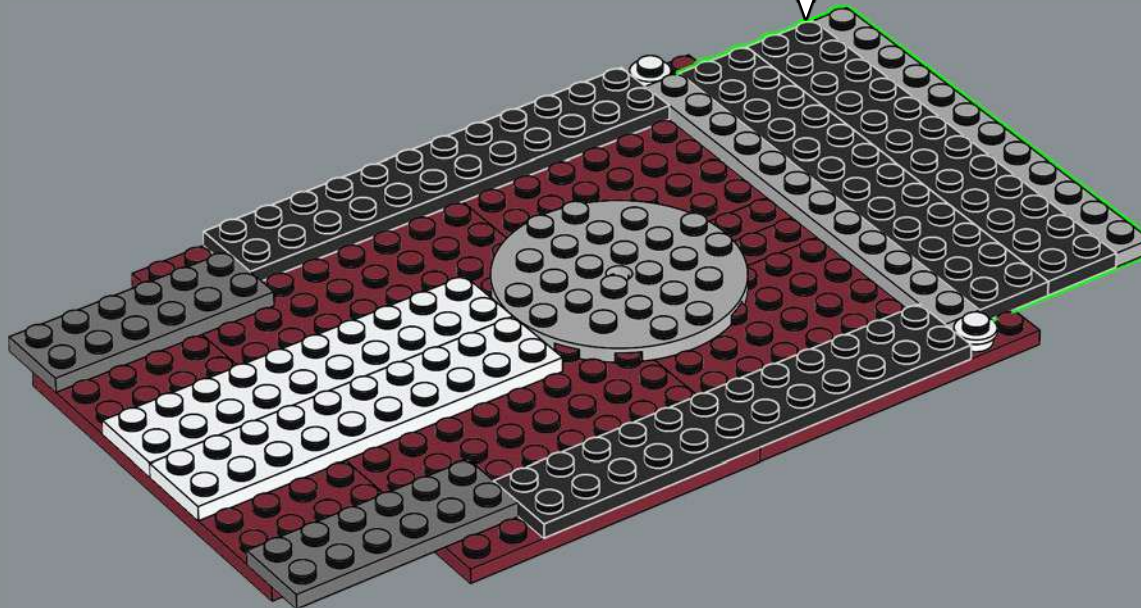
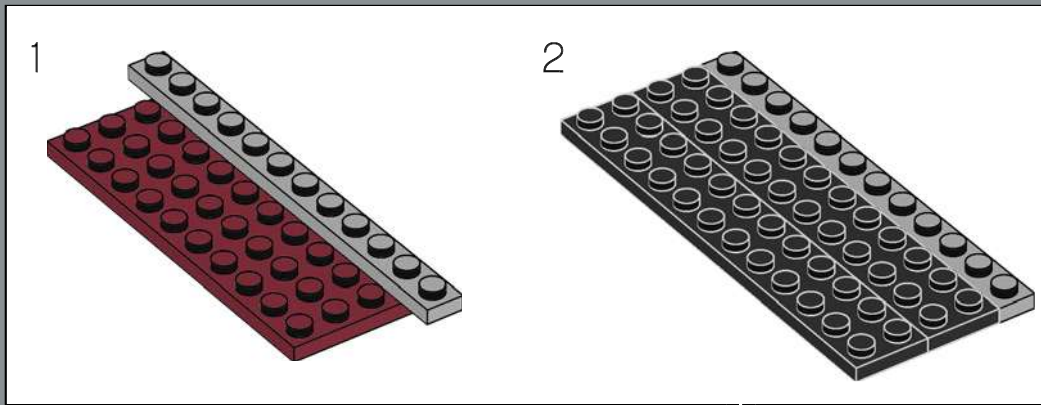



148

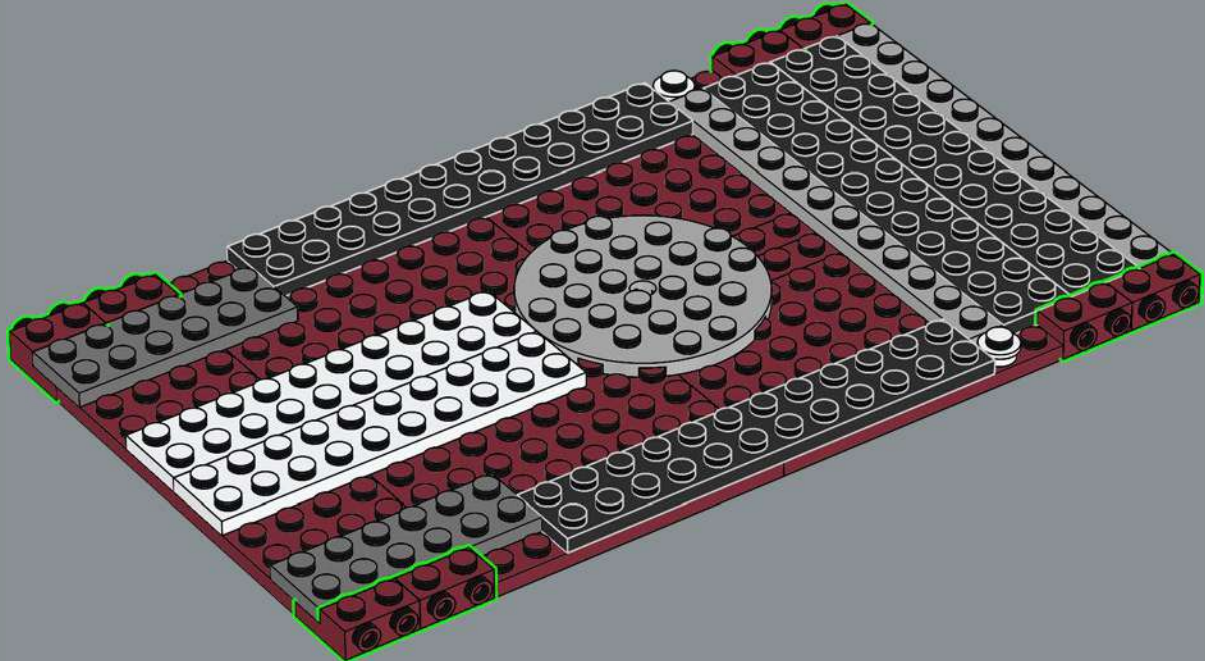

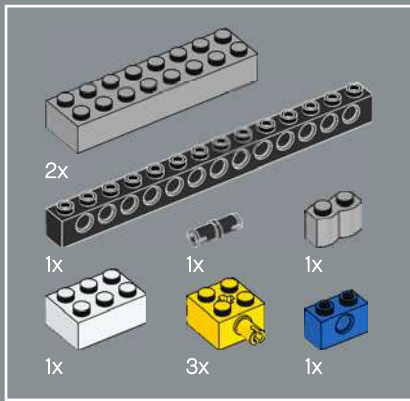

149

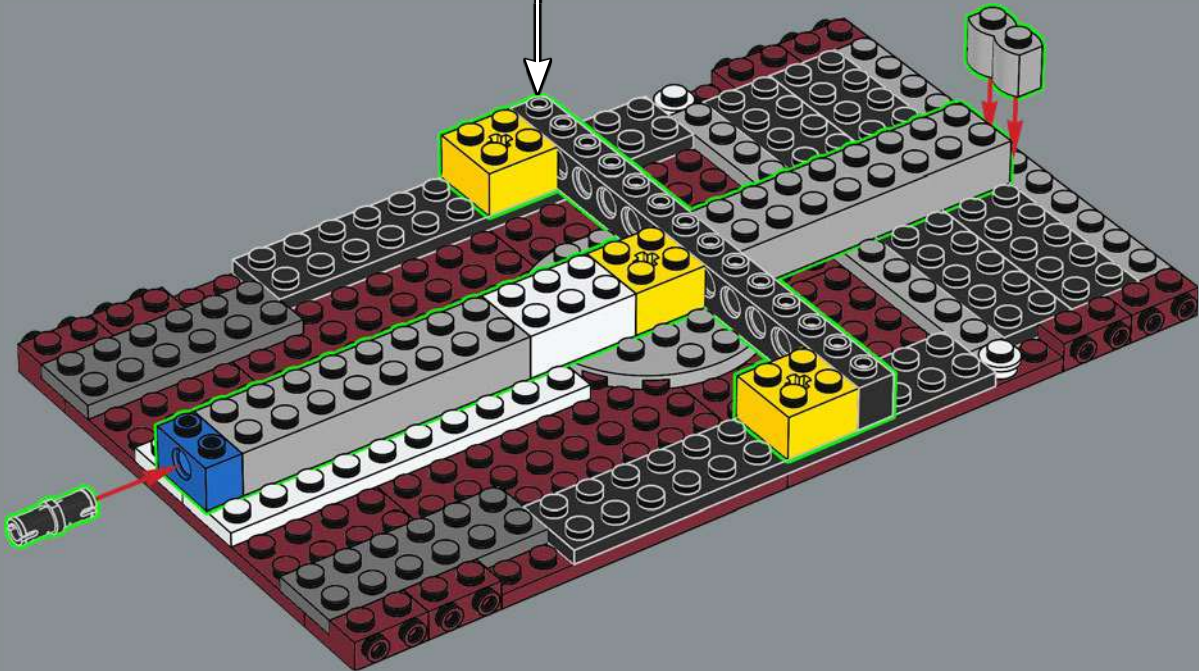
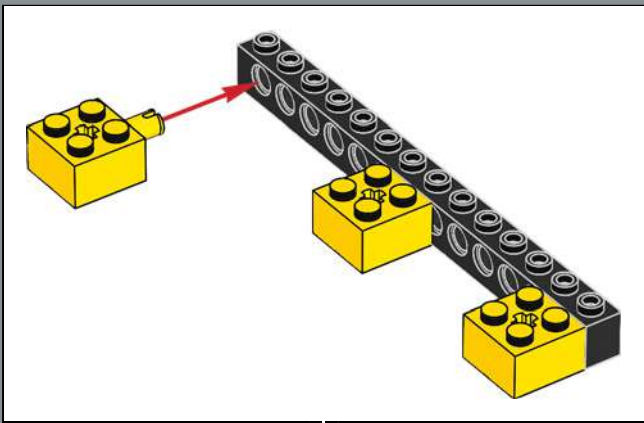

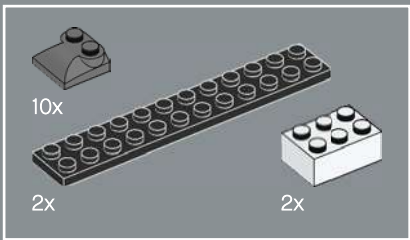

150

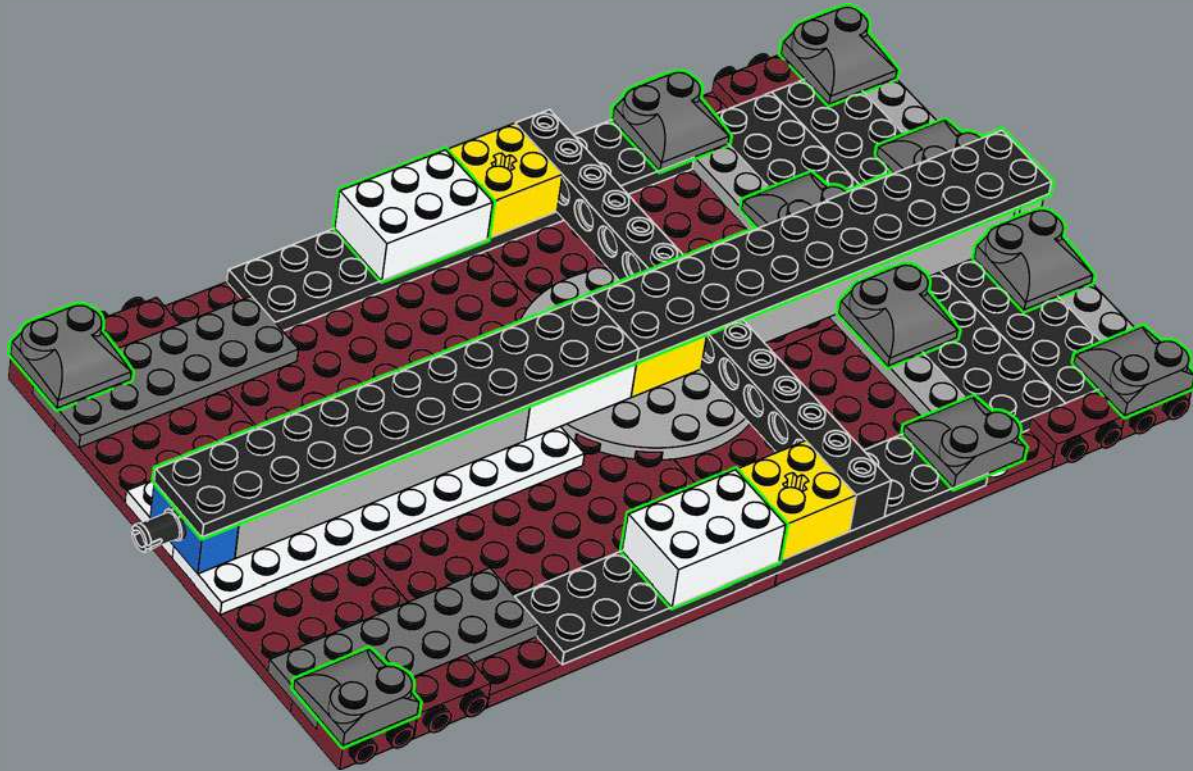

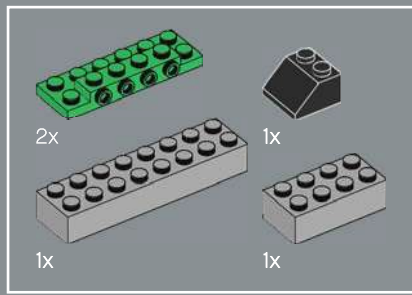

151

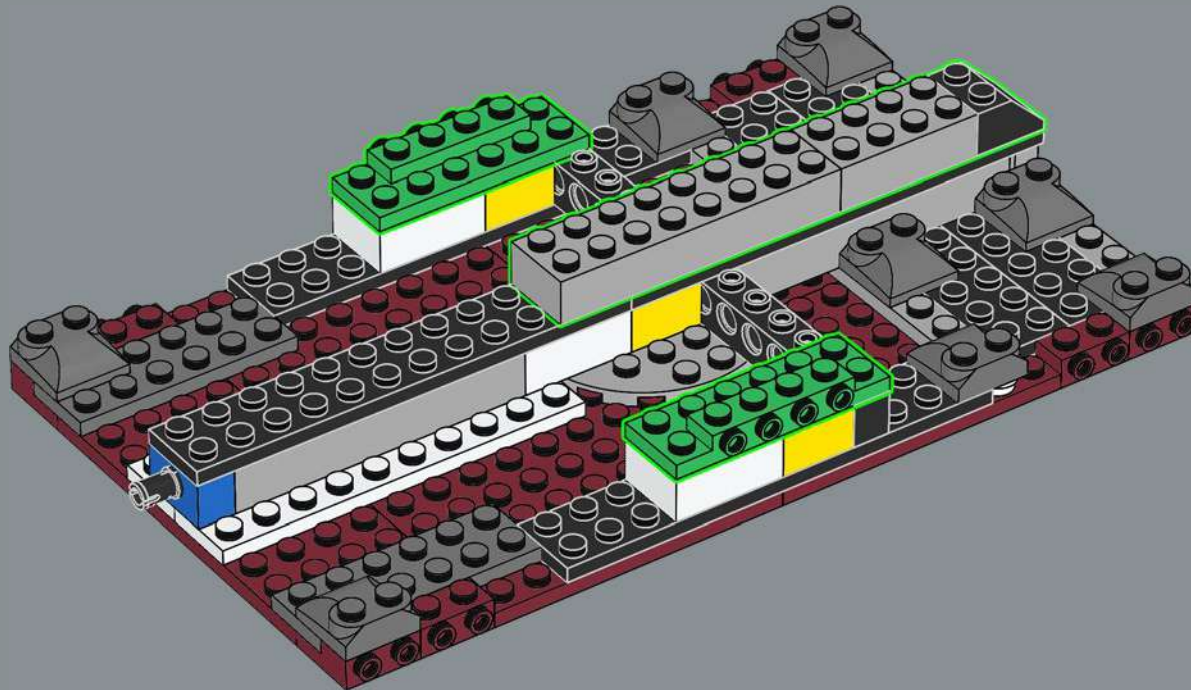

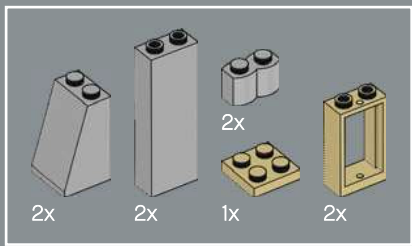

152

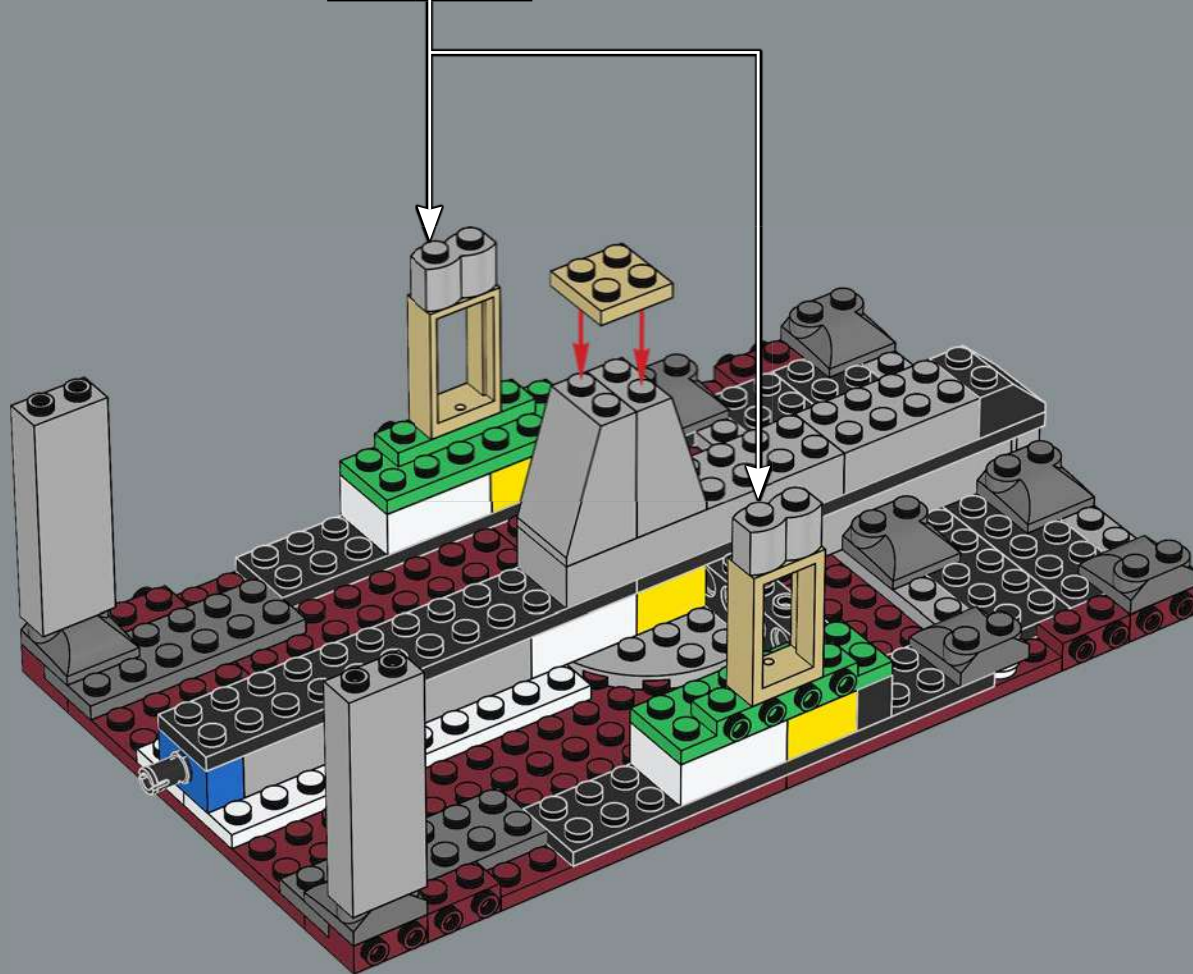
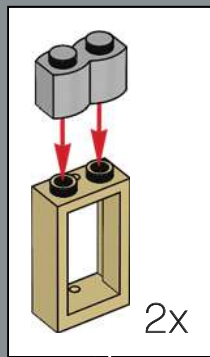

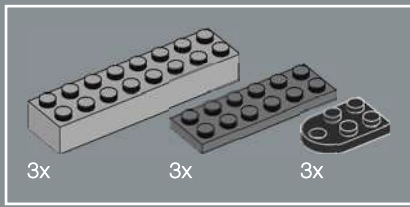

153

1

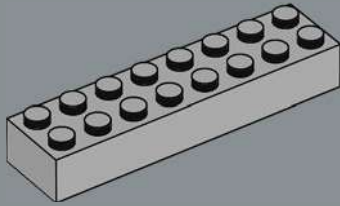

2

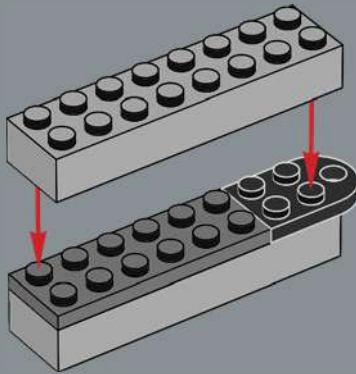

3

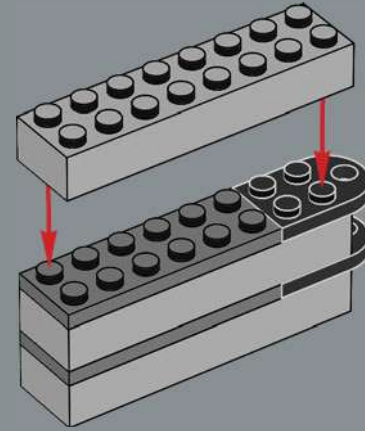

4

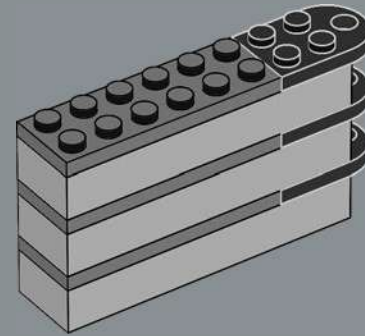

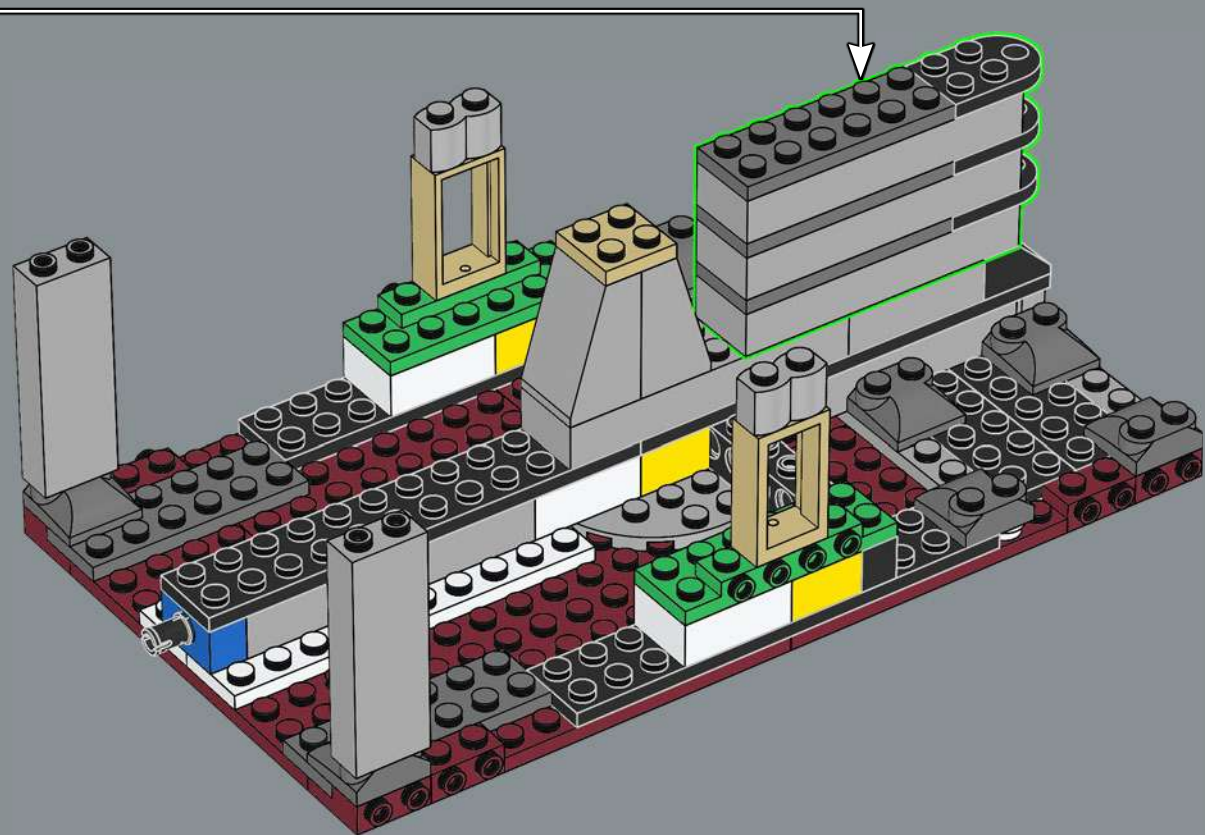

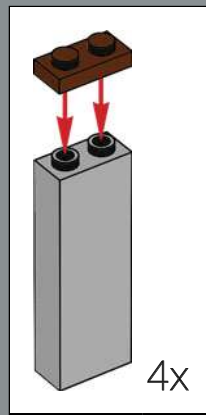
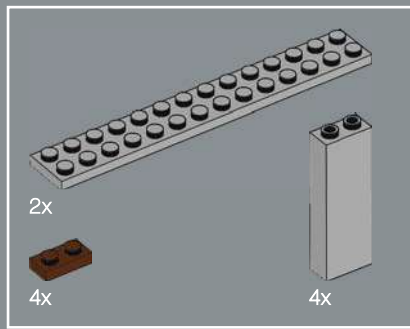

154

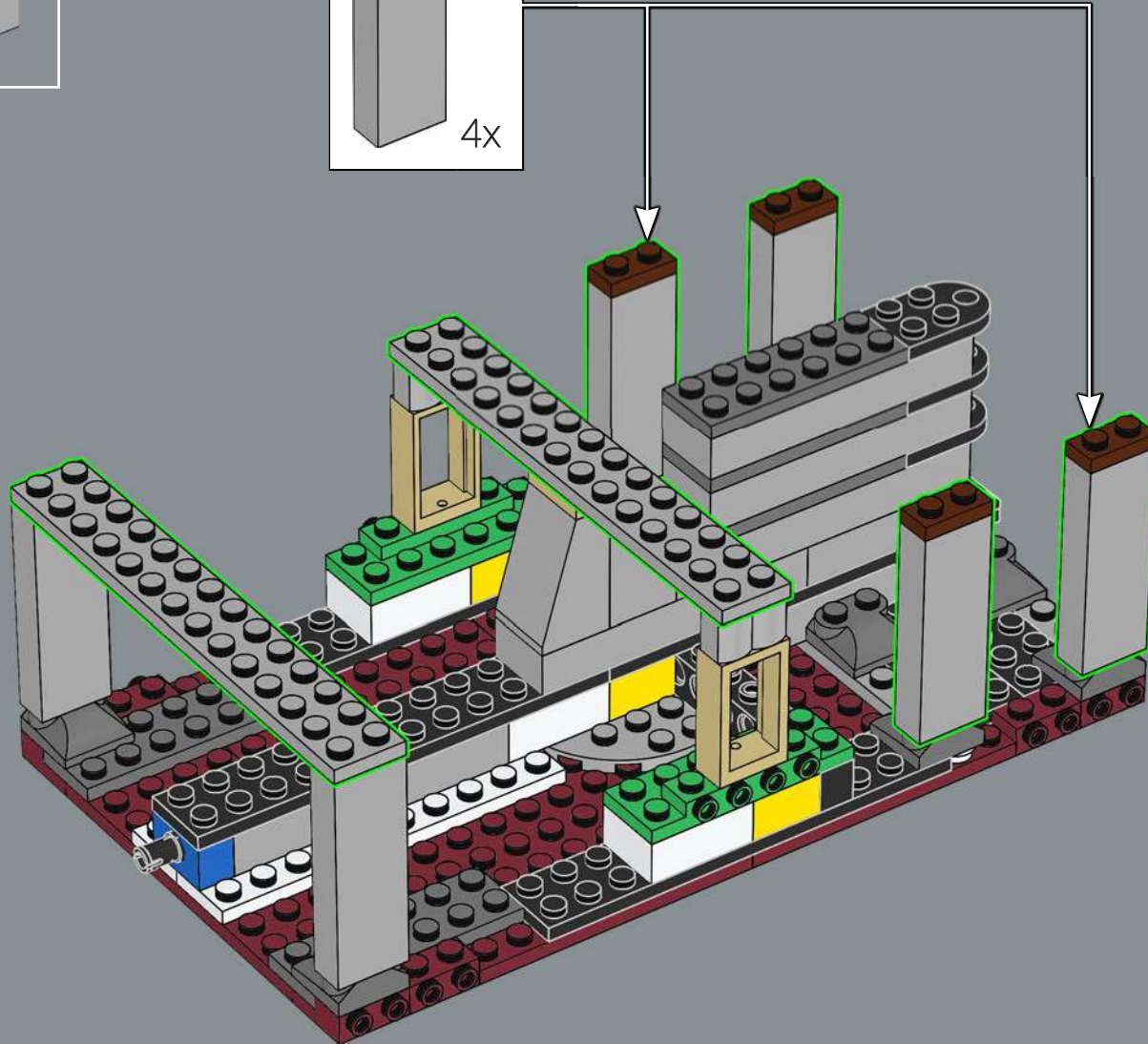

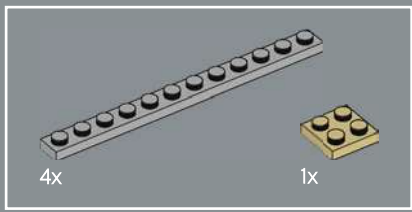

155

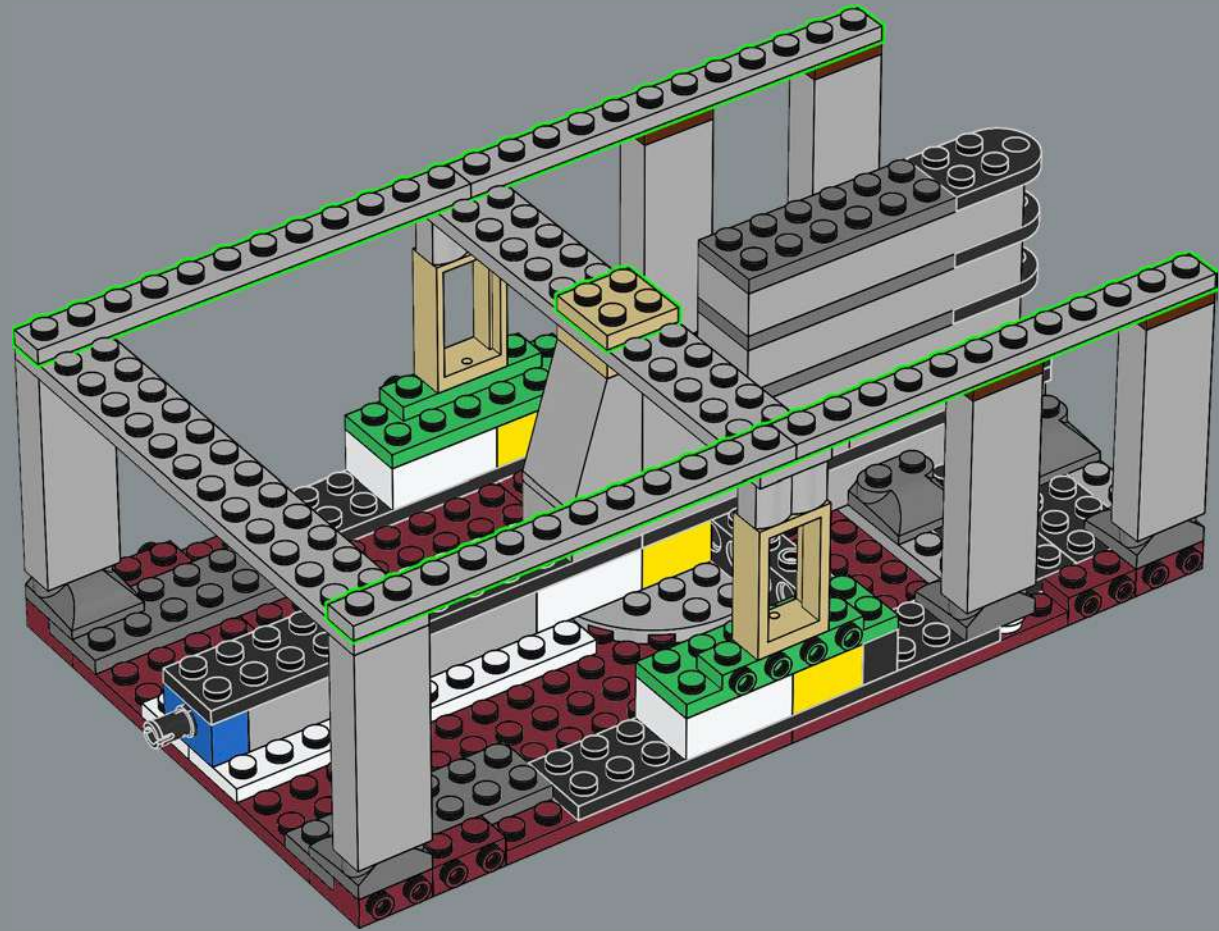

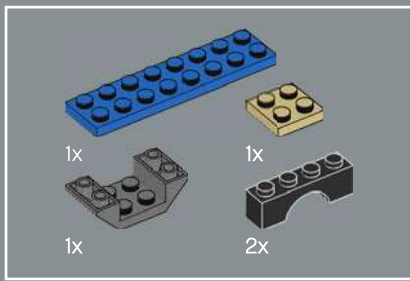

156

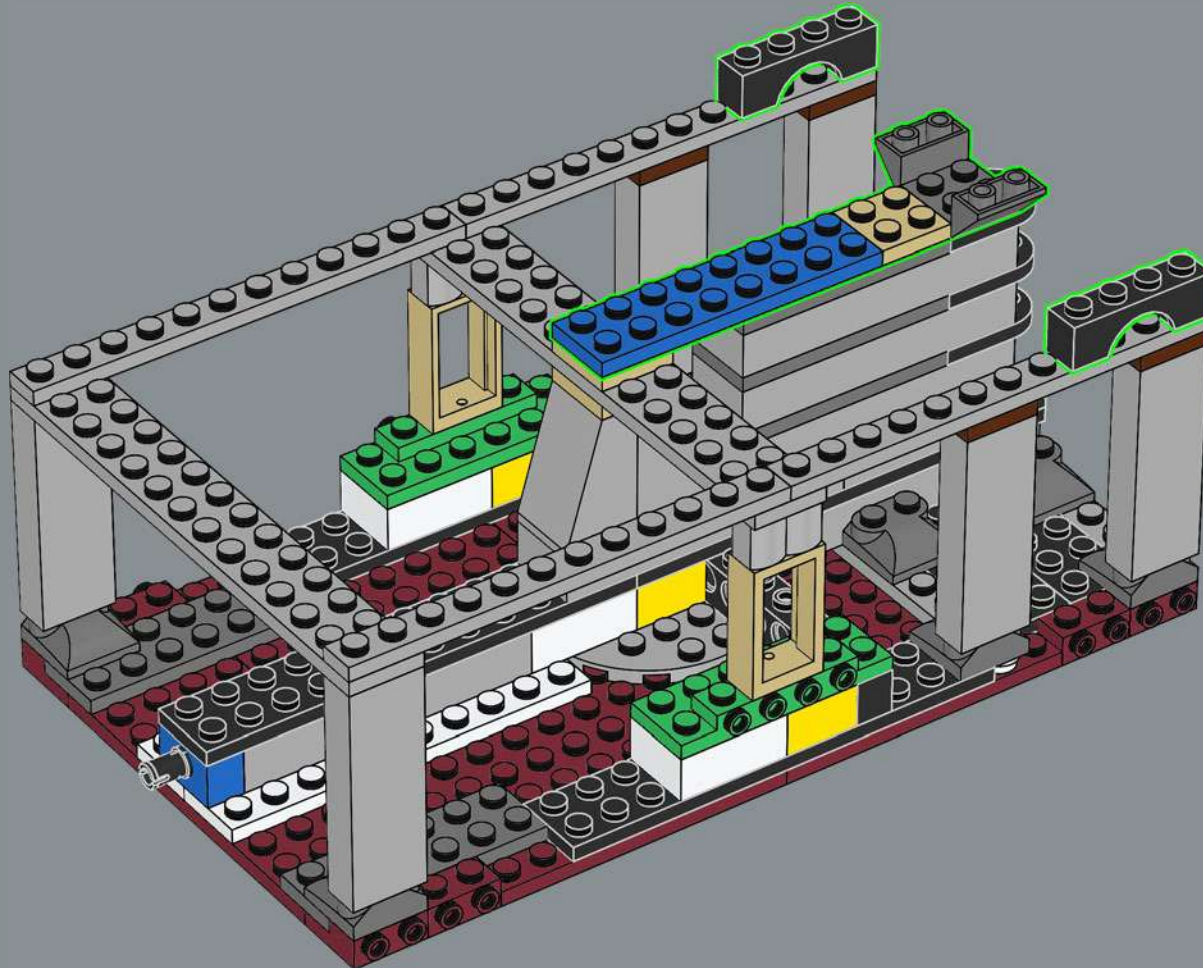

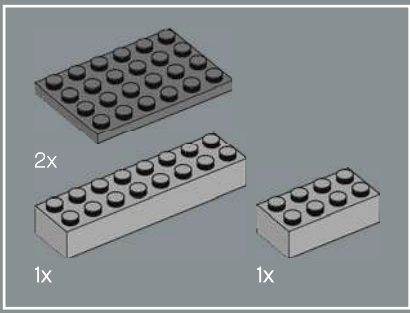

157

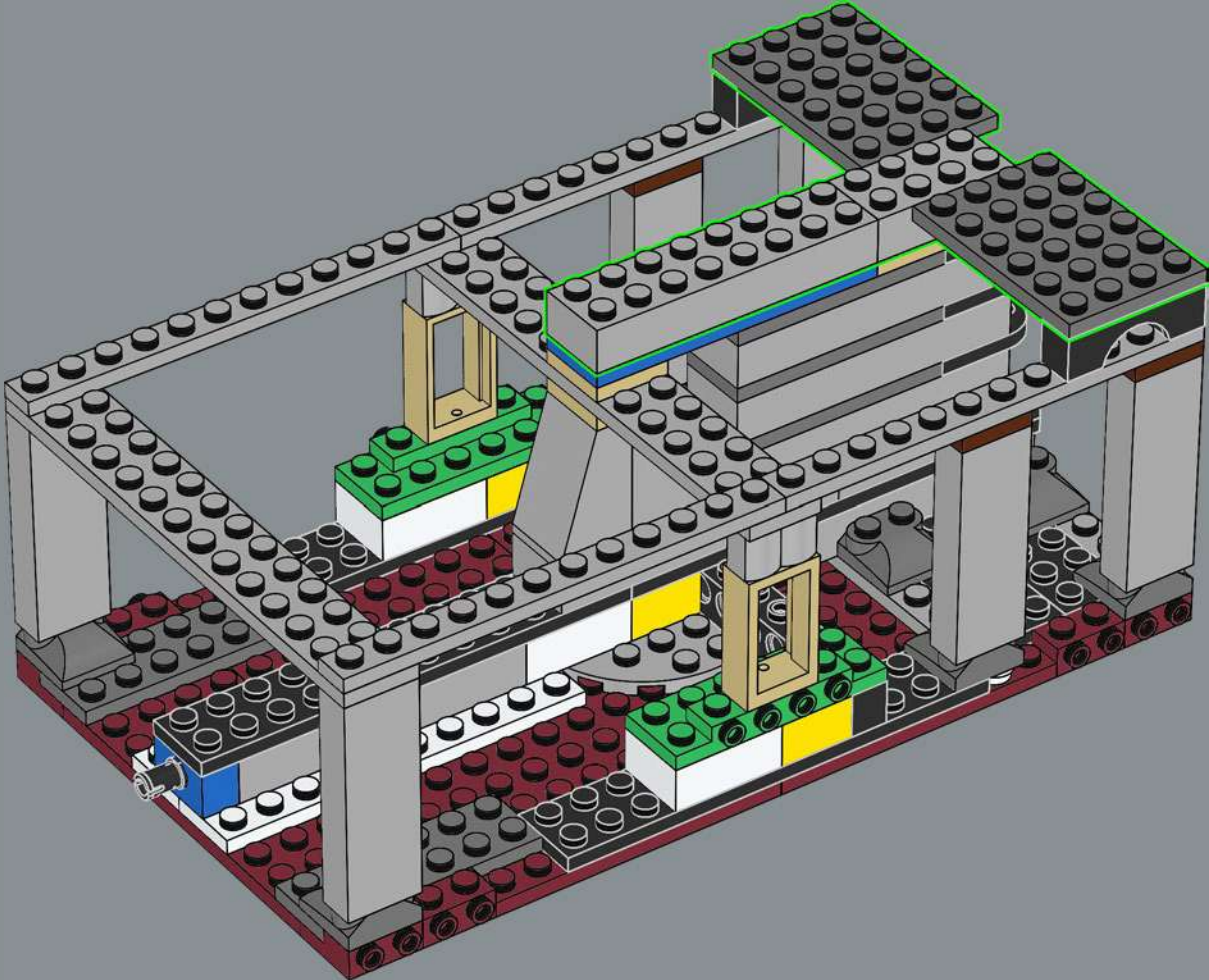

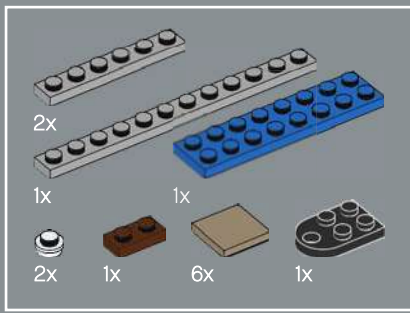

158

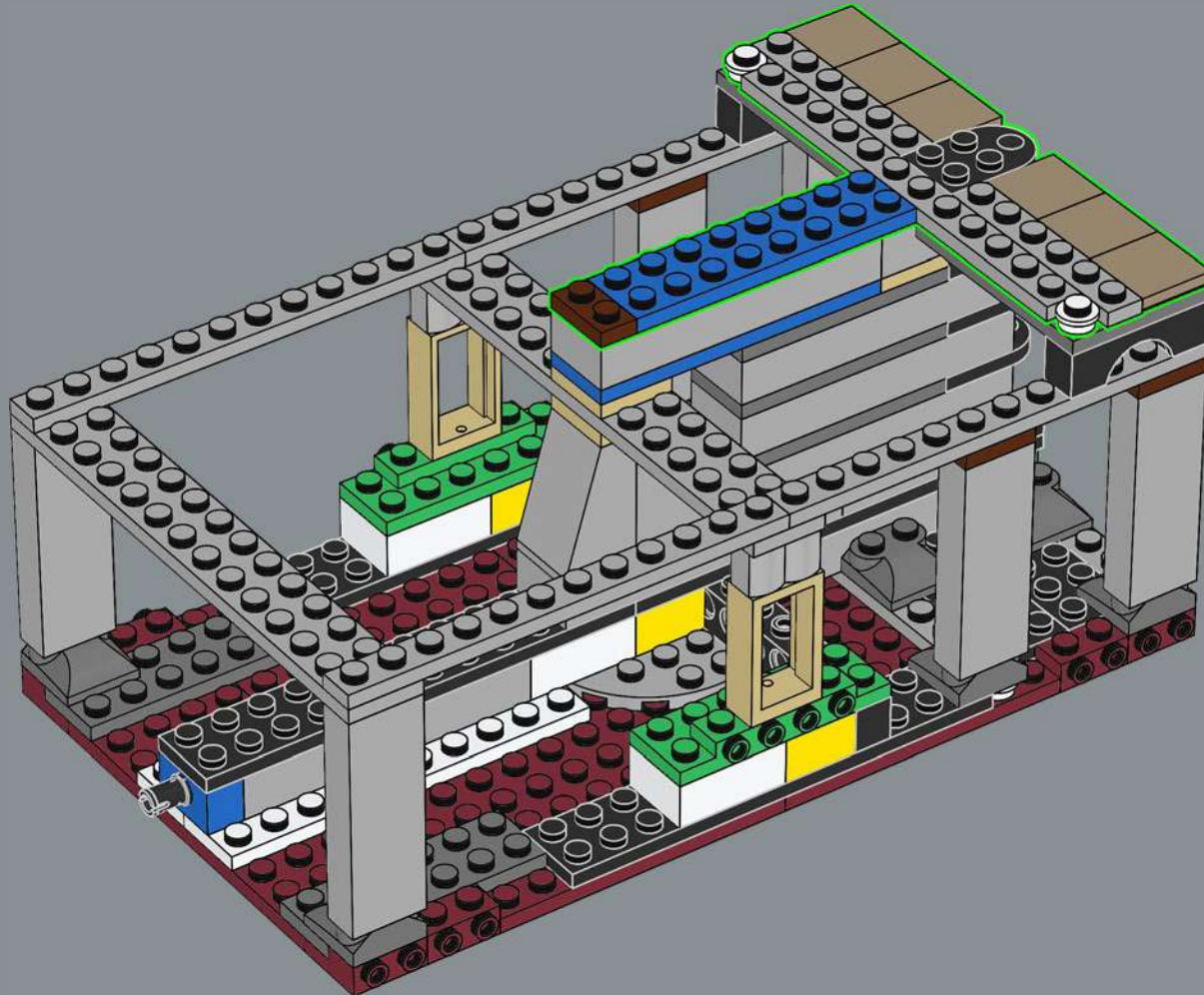

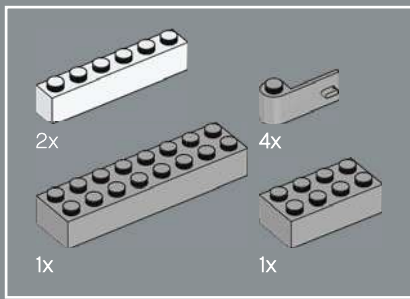

159

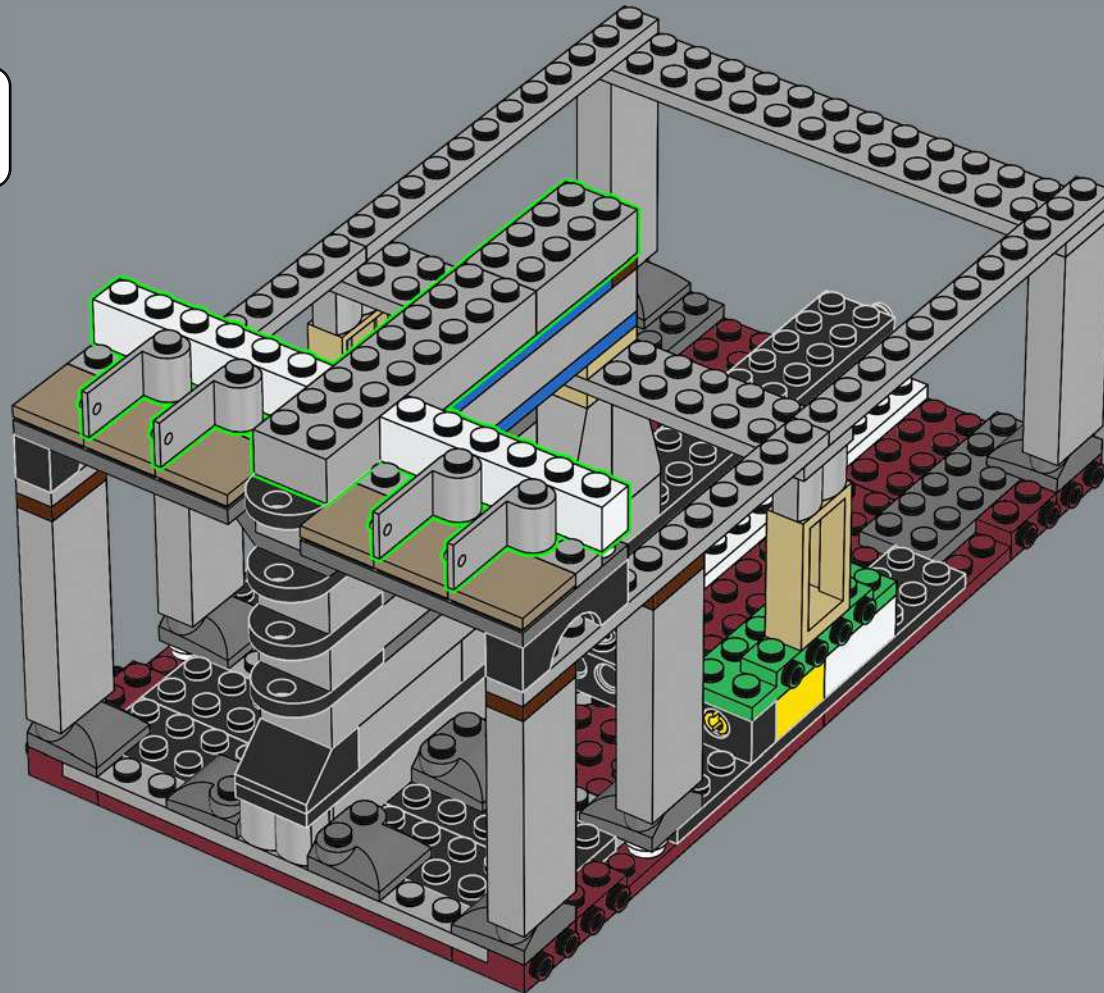

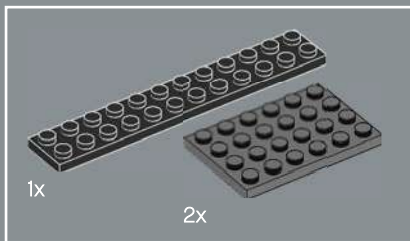

160

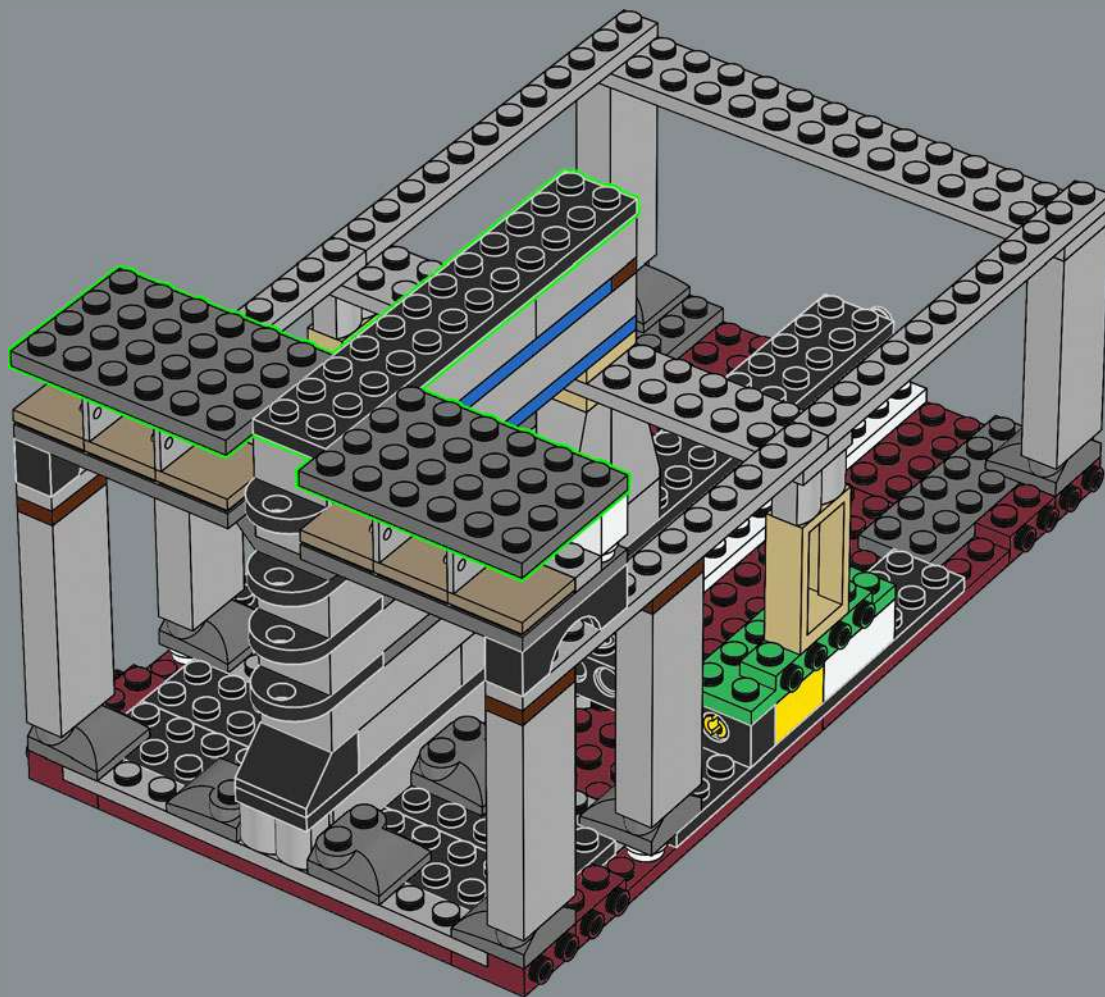

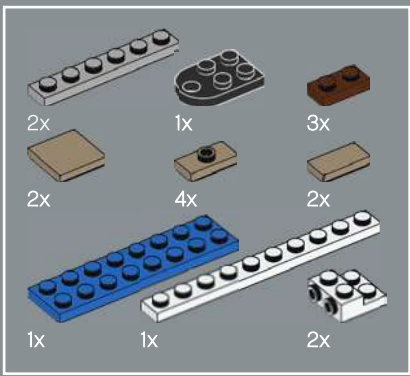

161

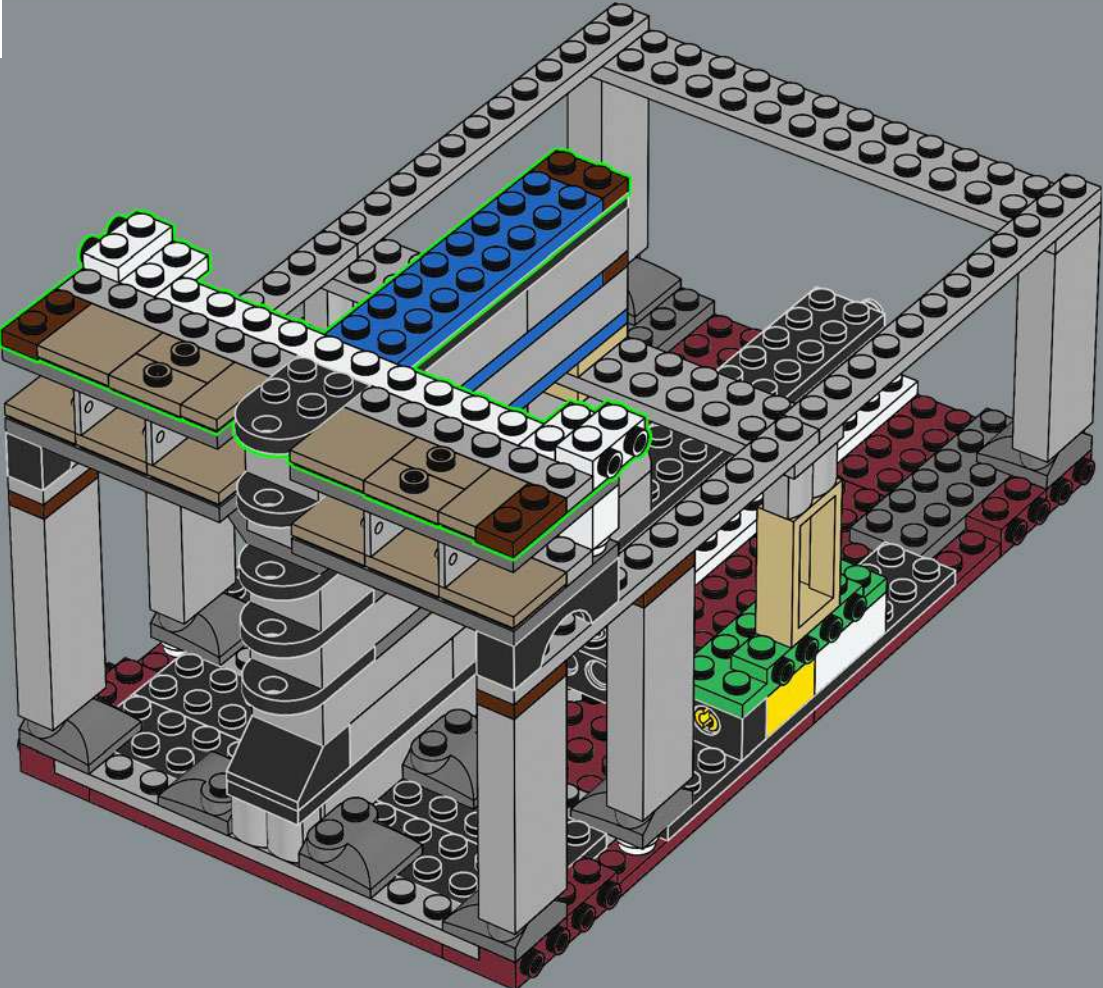

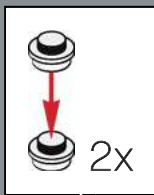
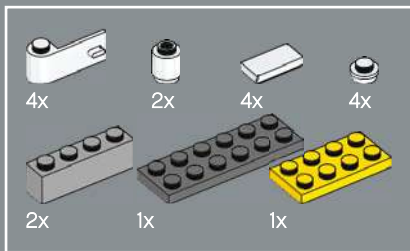

162

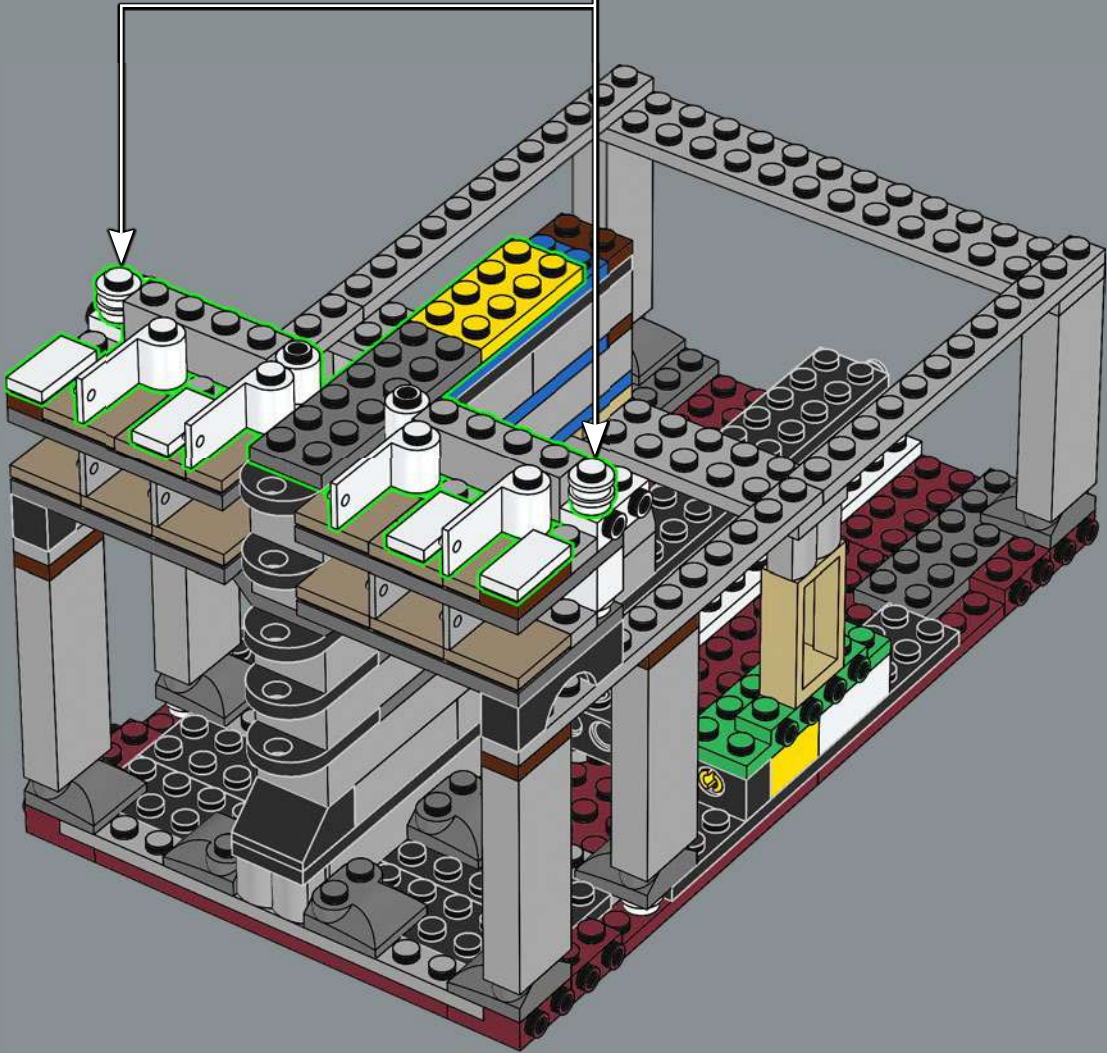

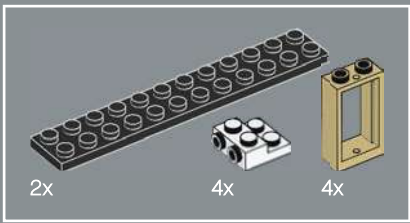

163

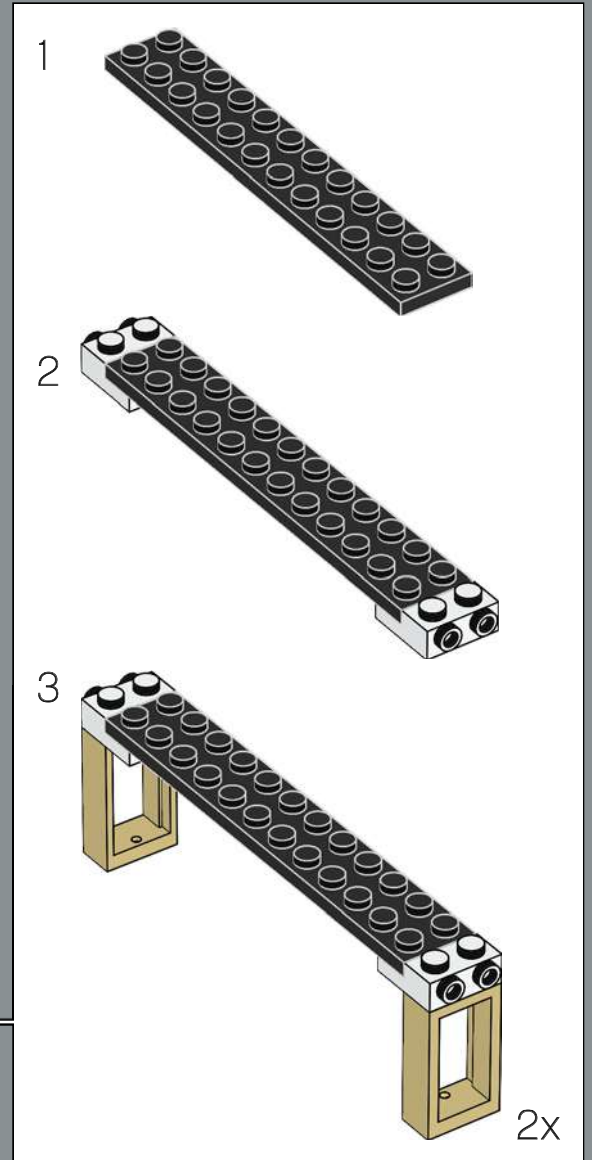
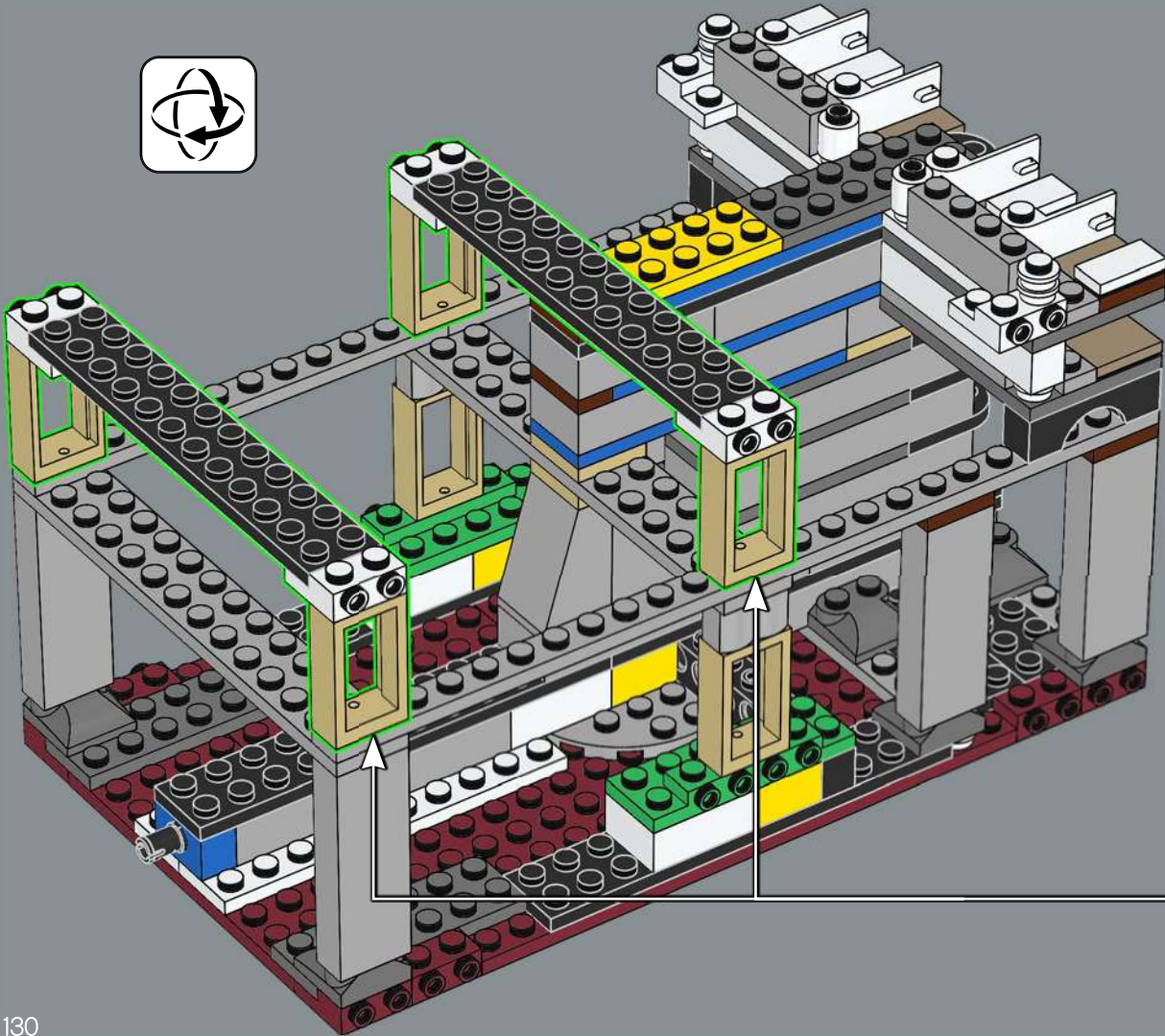

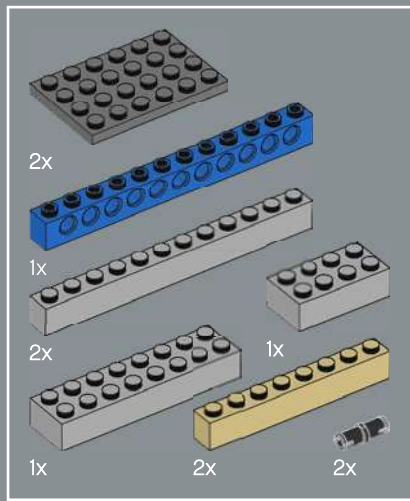

164

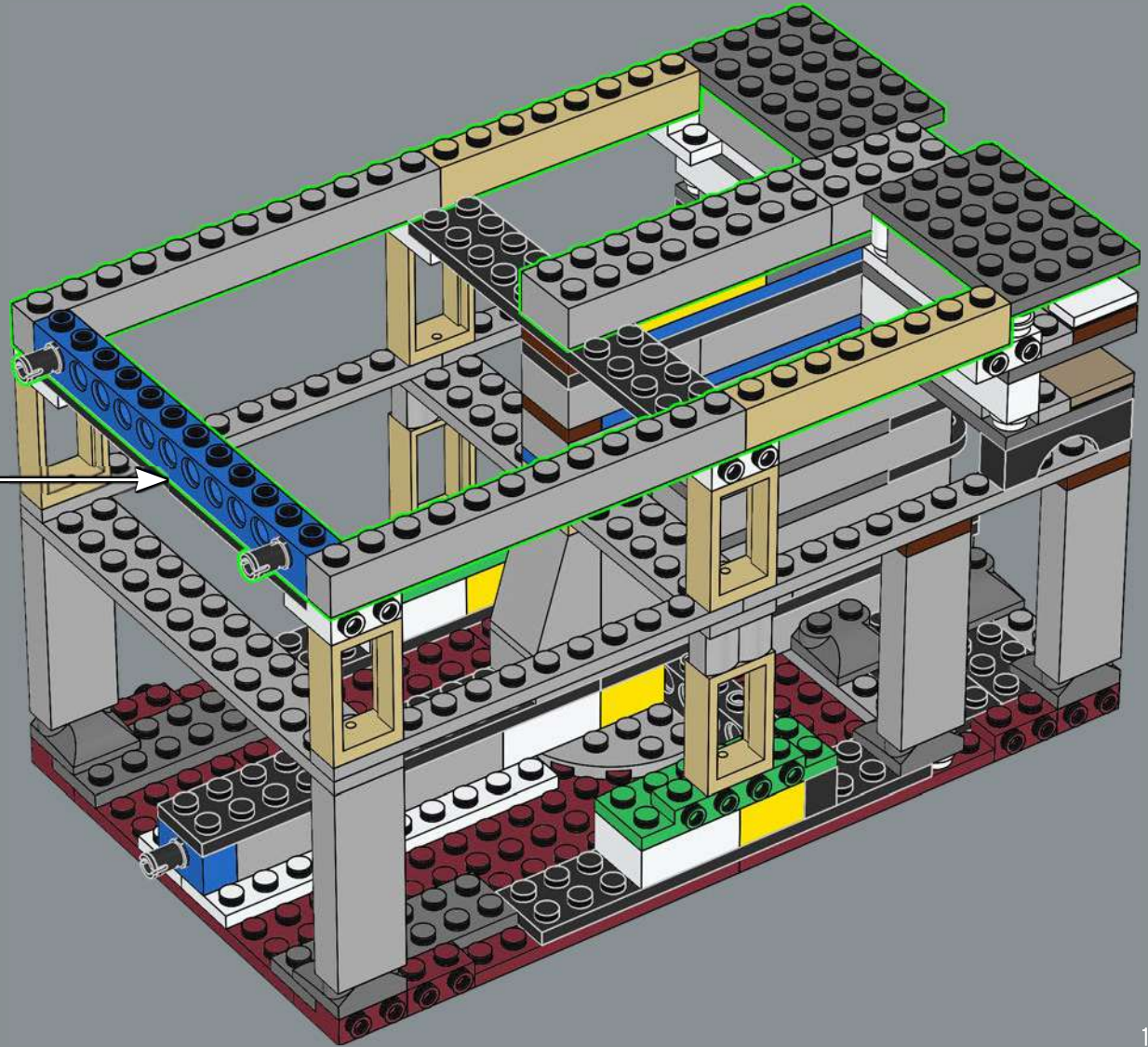
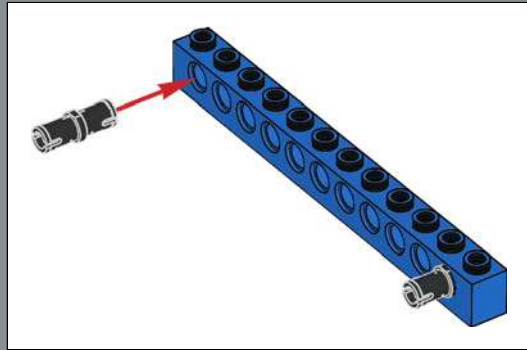

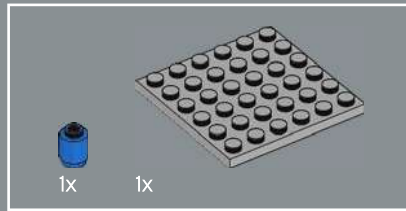
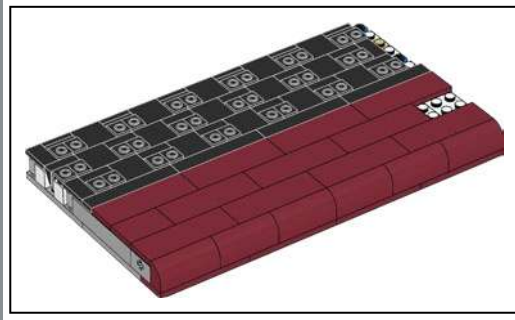
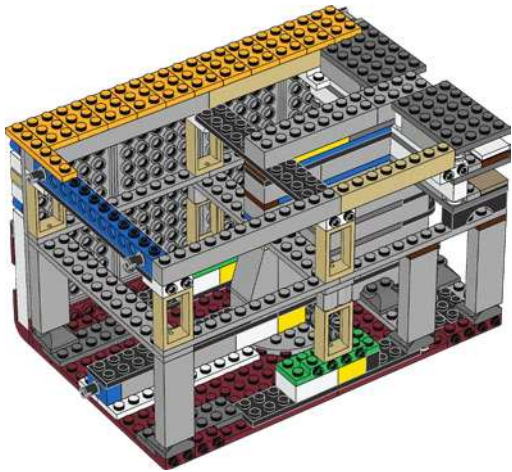
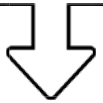

165

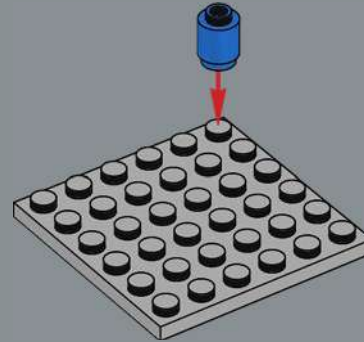

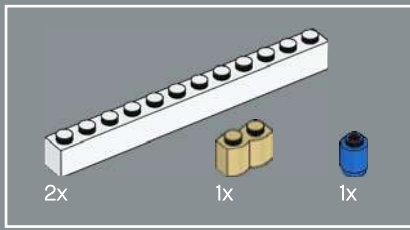

166

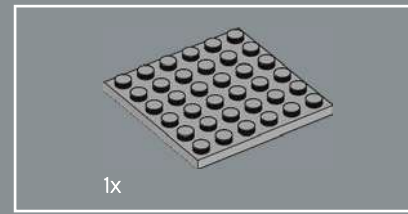
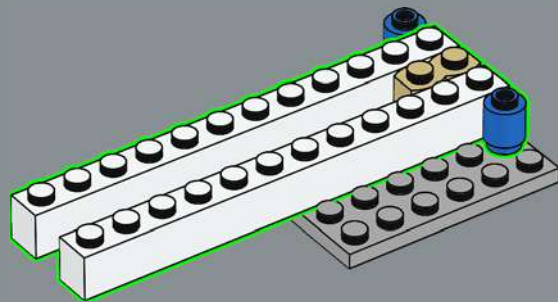

167

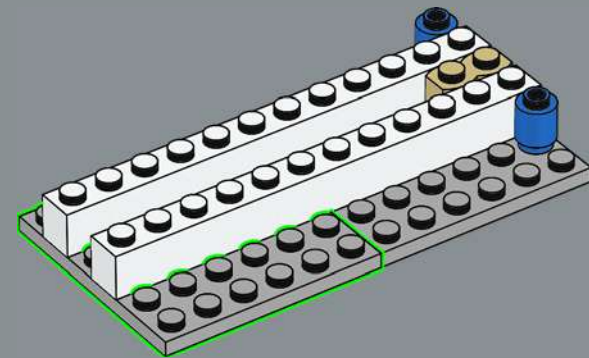

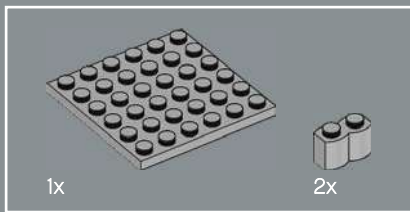

168

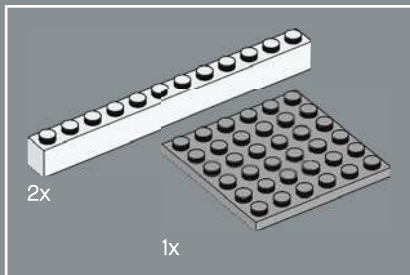
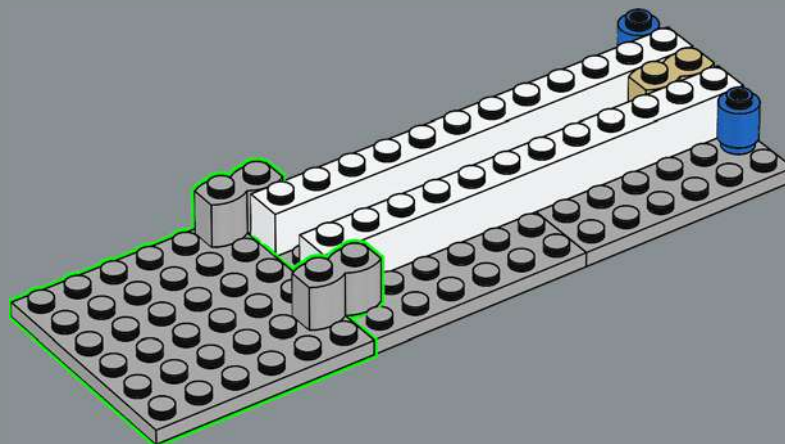

169

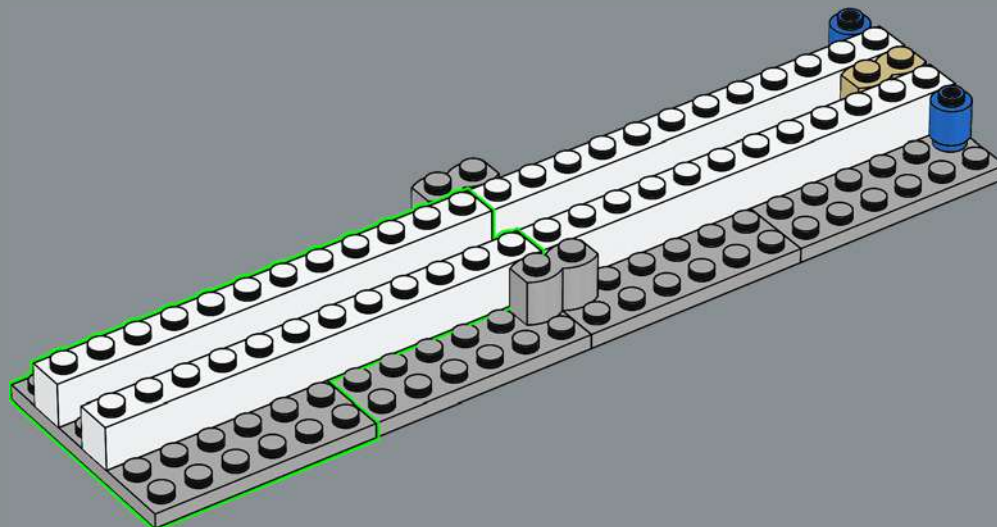



170

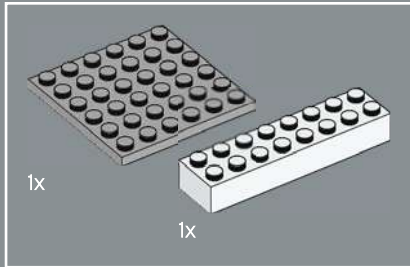
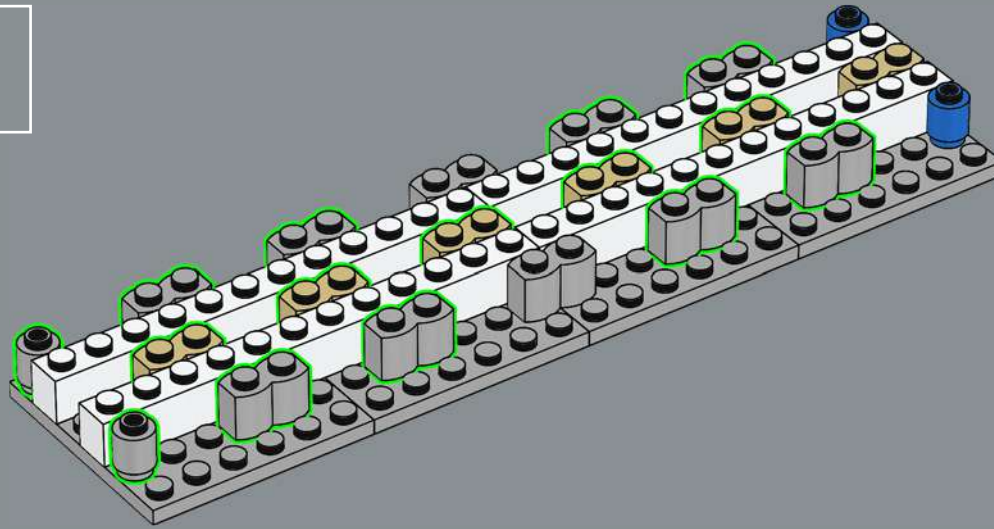

171

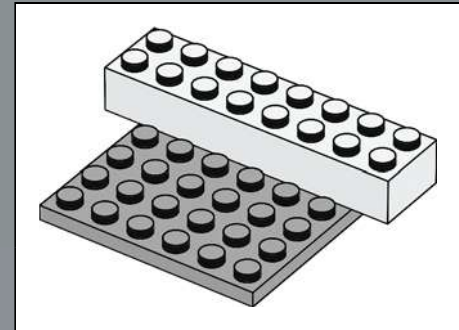
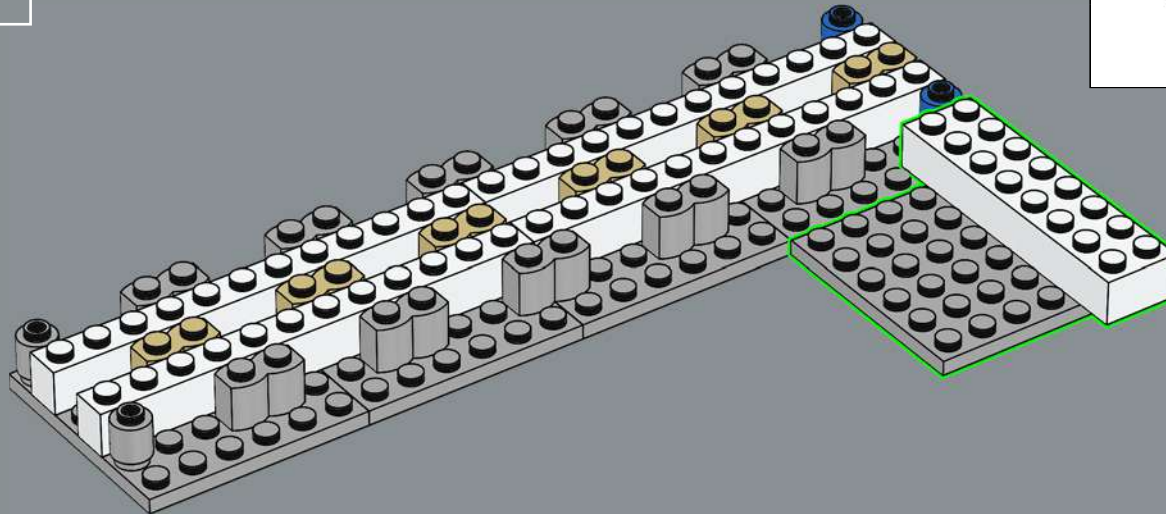

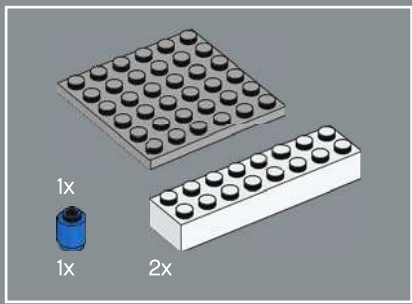

172

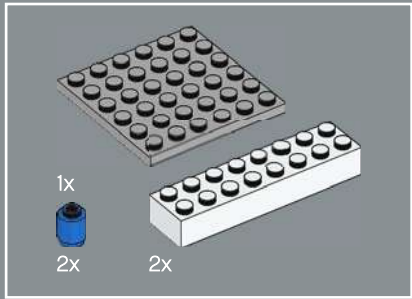
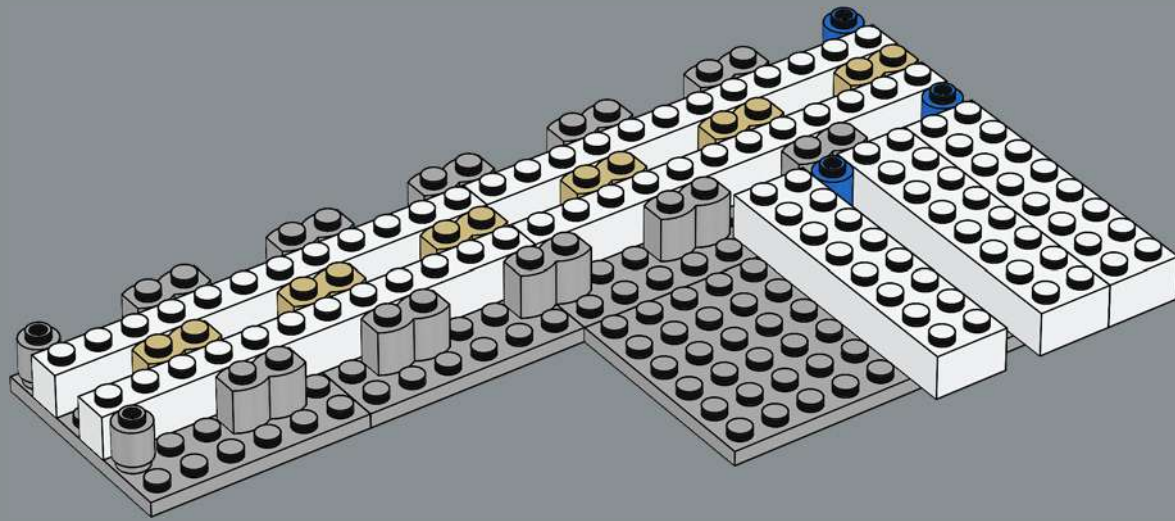

173

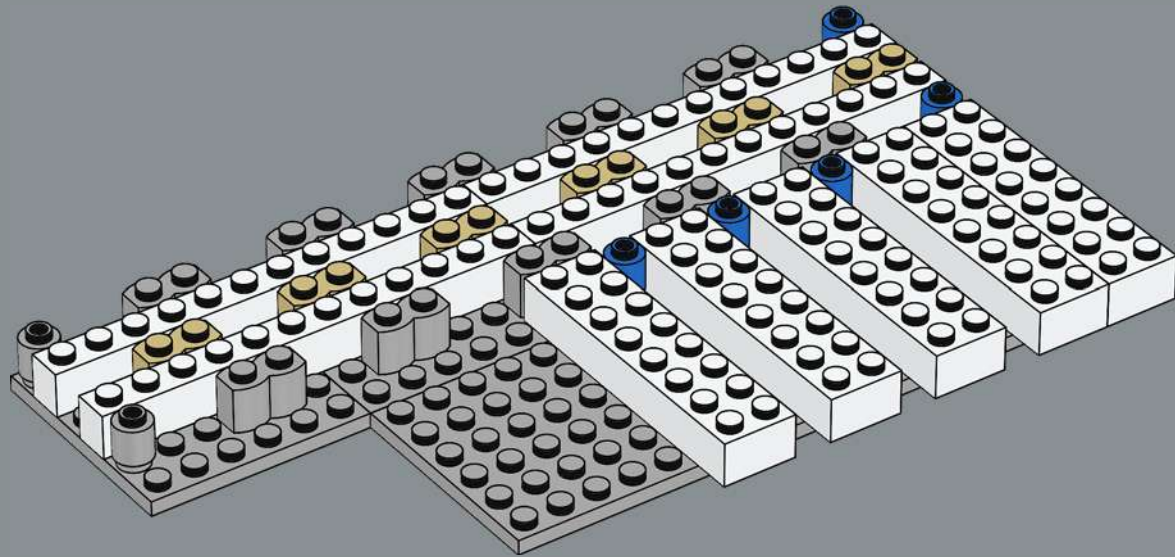

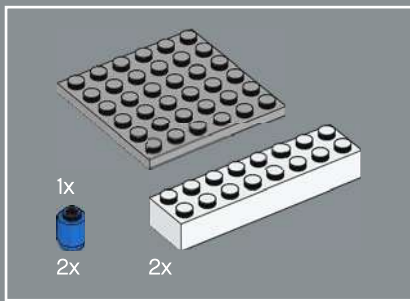

174

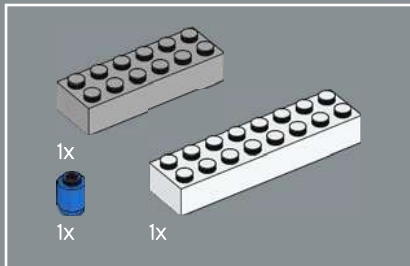
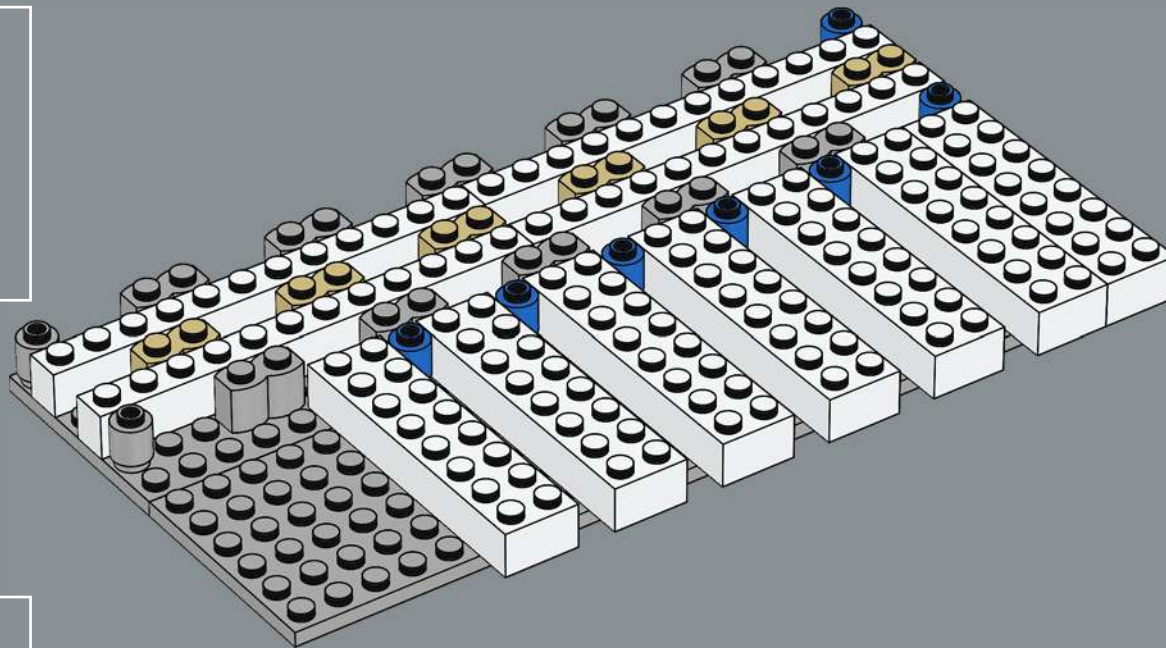

175

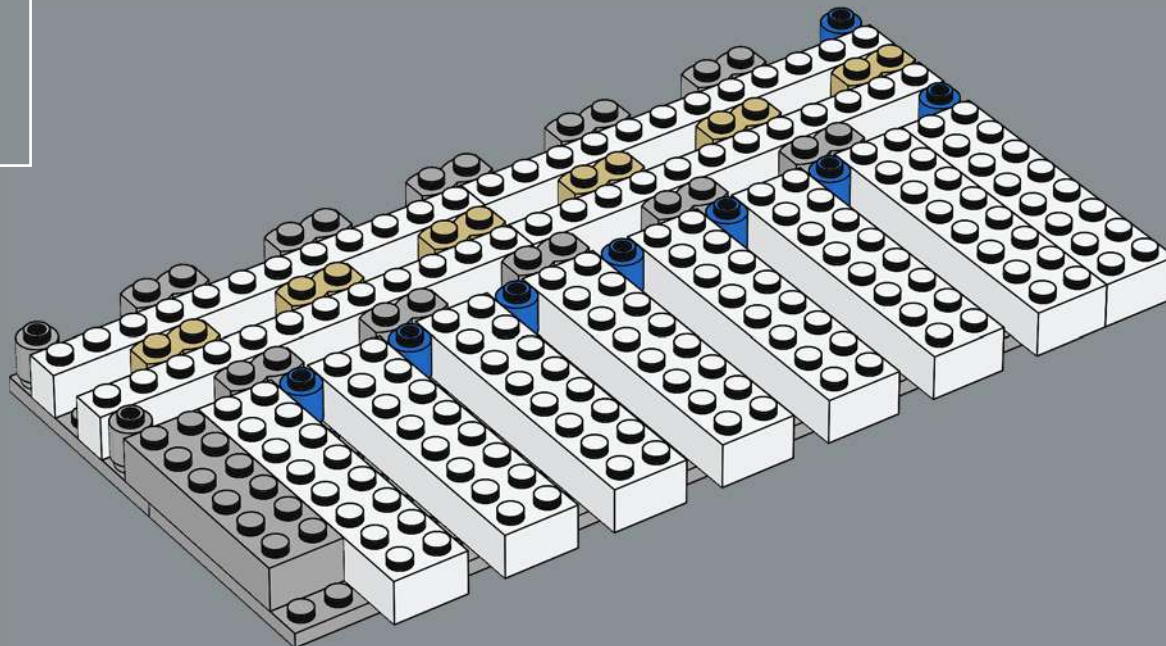

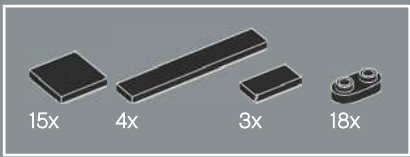

176

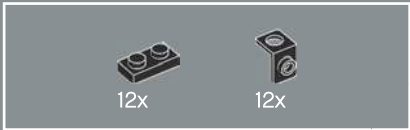
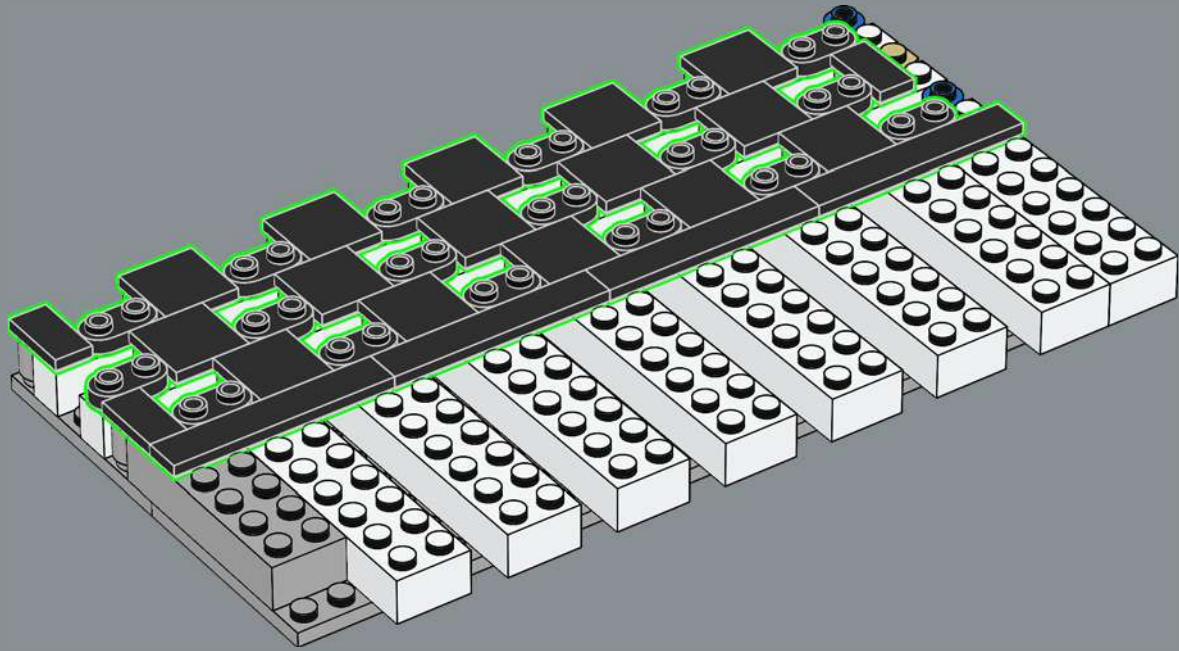

177

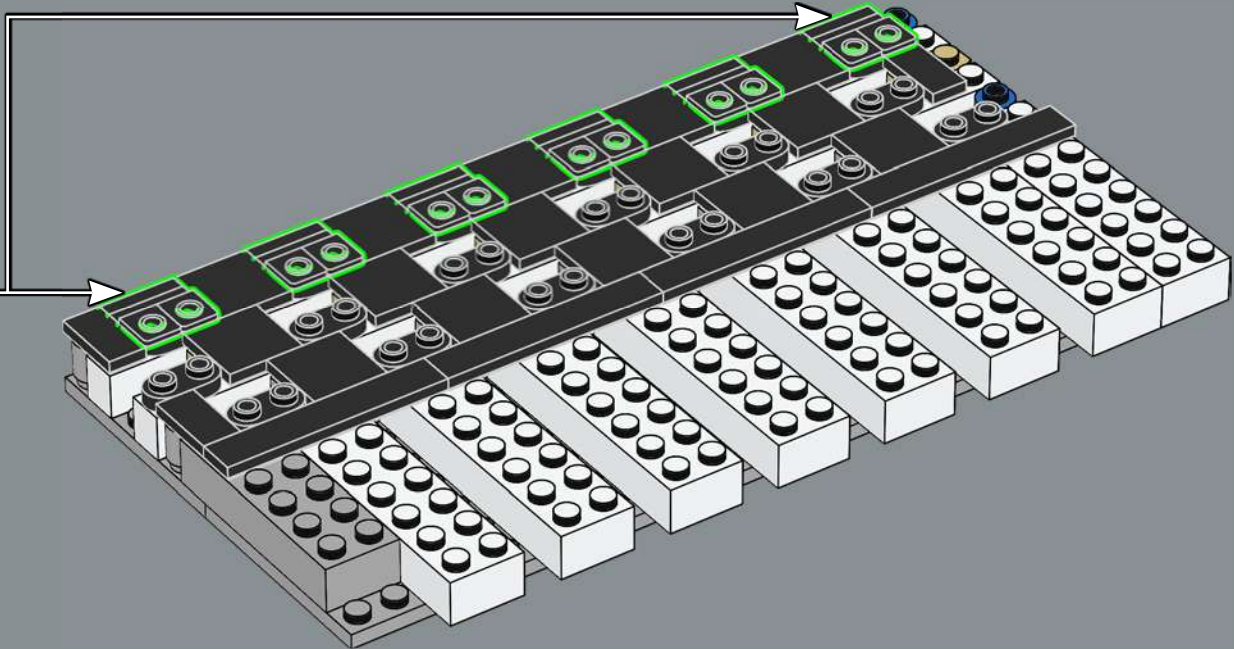
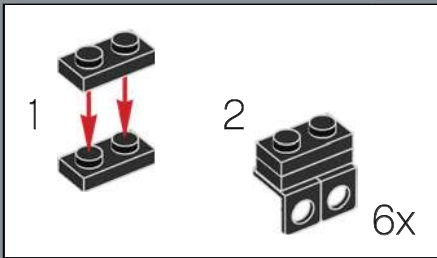



178

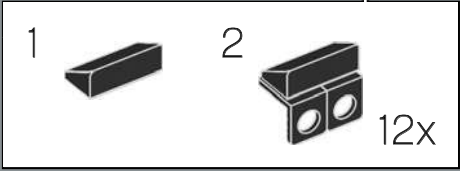
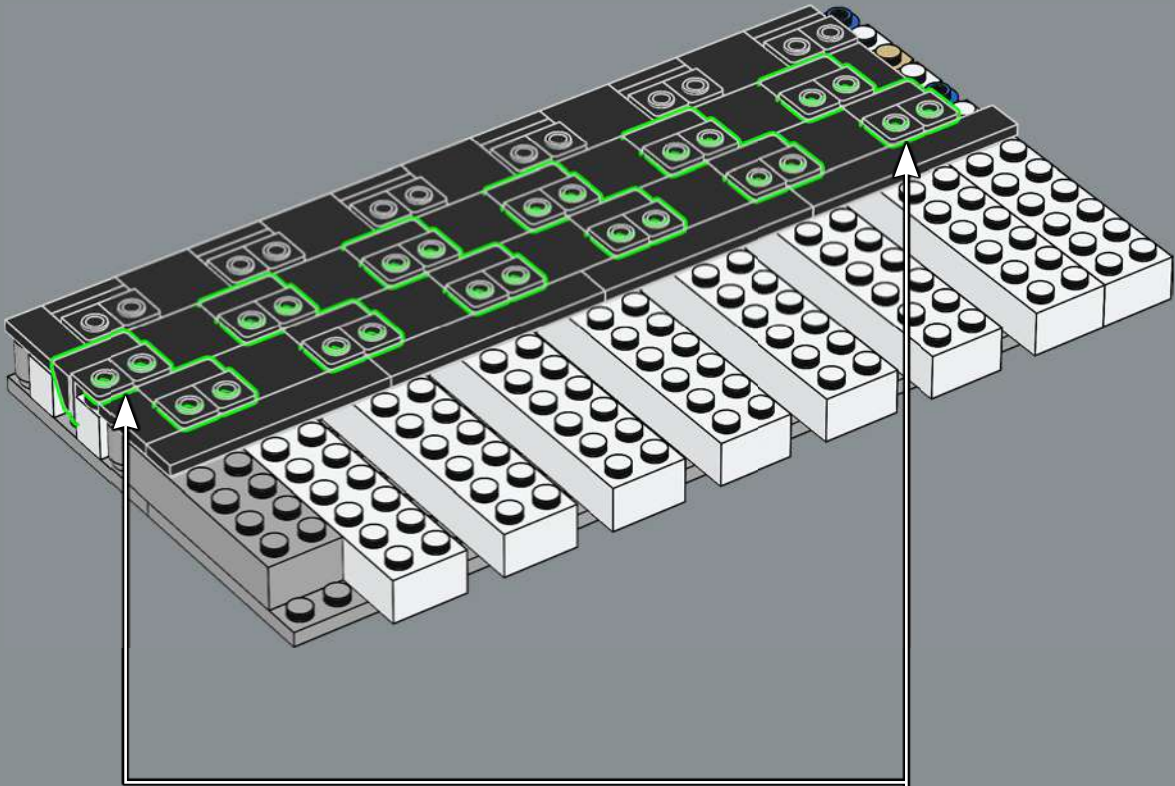

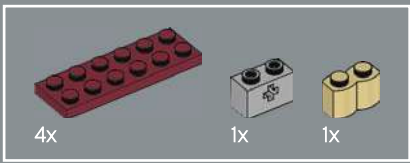

179

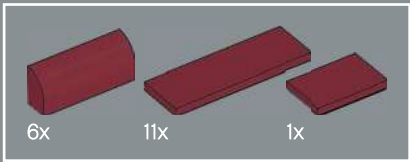
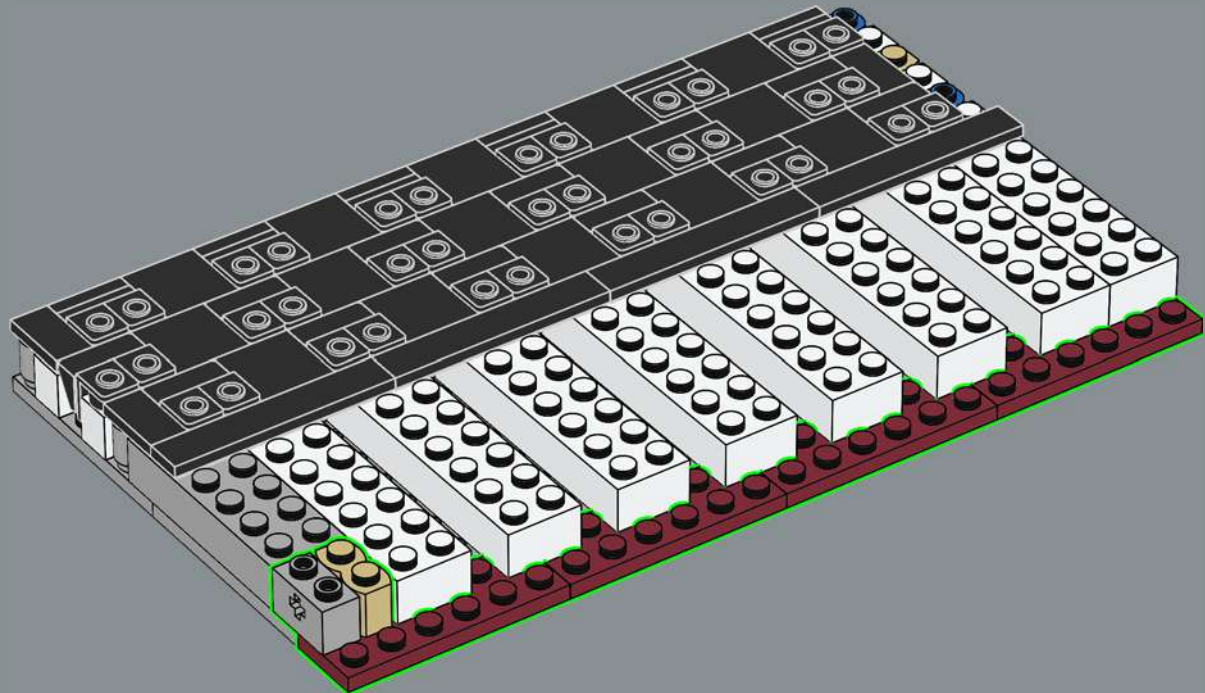

180

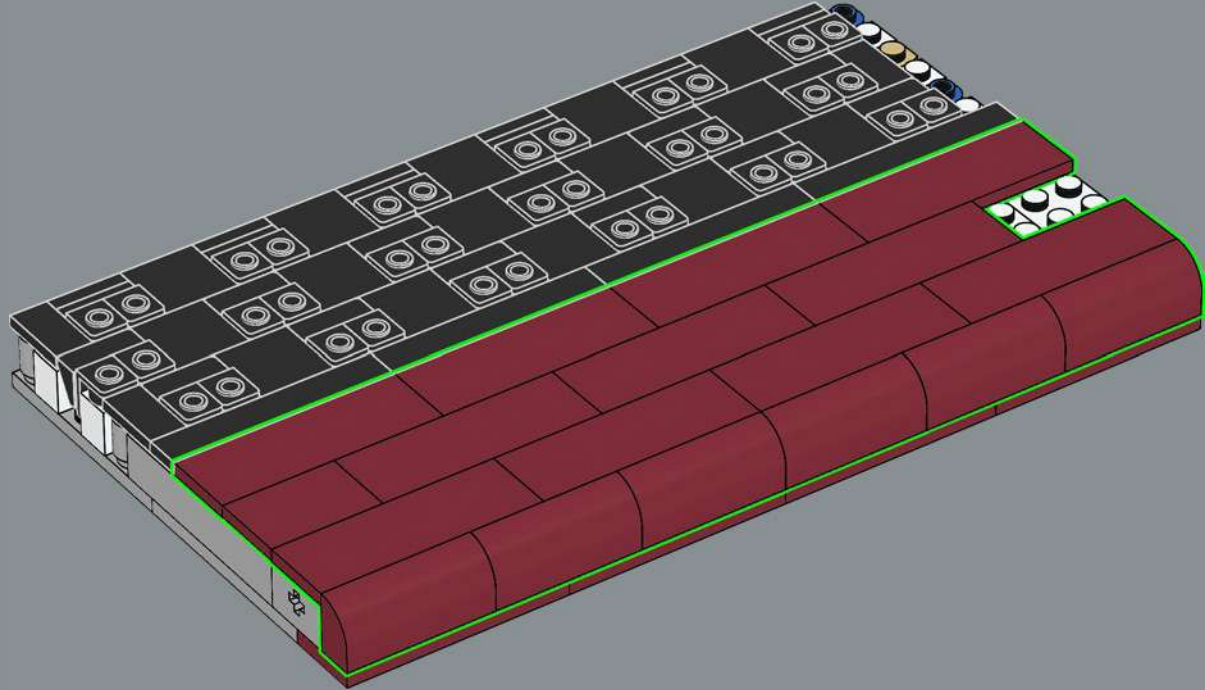

The ship's hull was held together with over three million iron and steel rivets weighing over 1,200 tonnes (1,322.7 US tons).

181

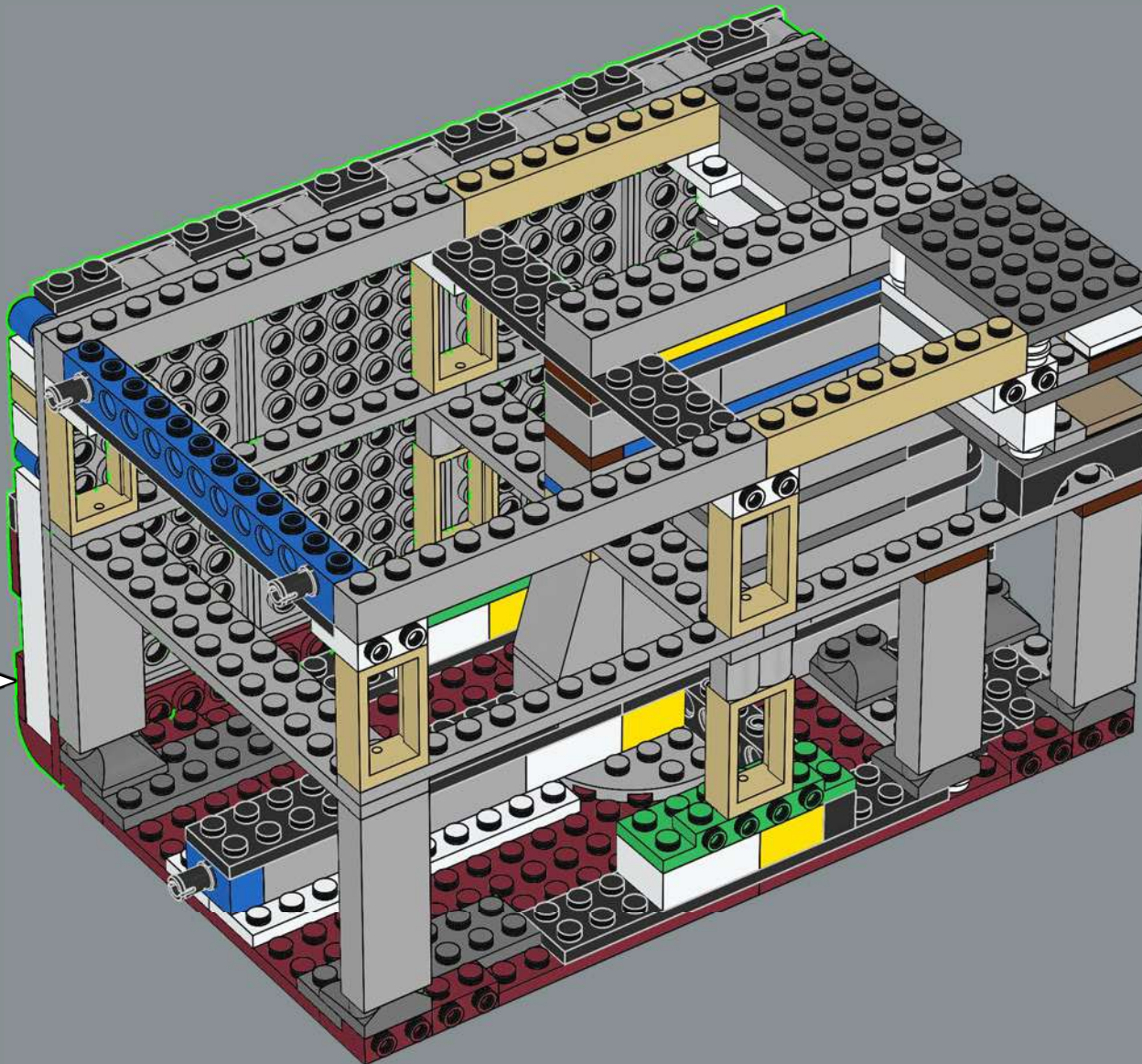

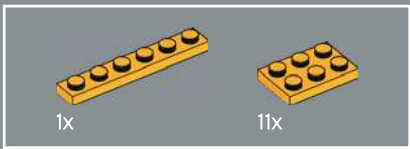

182

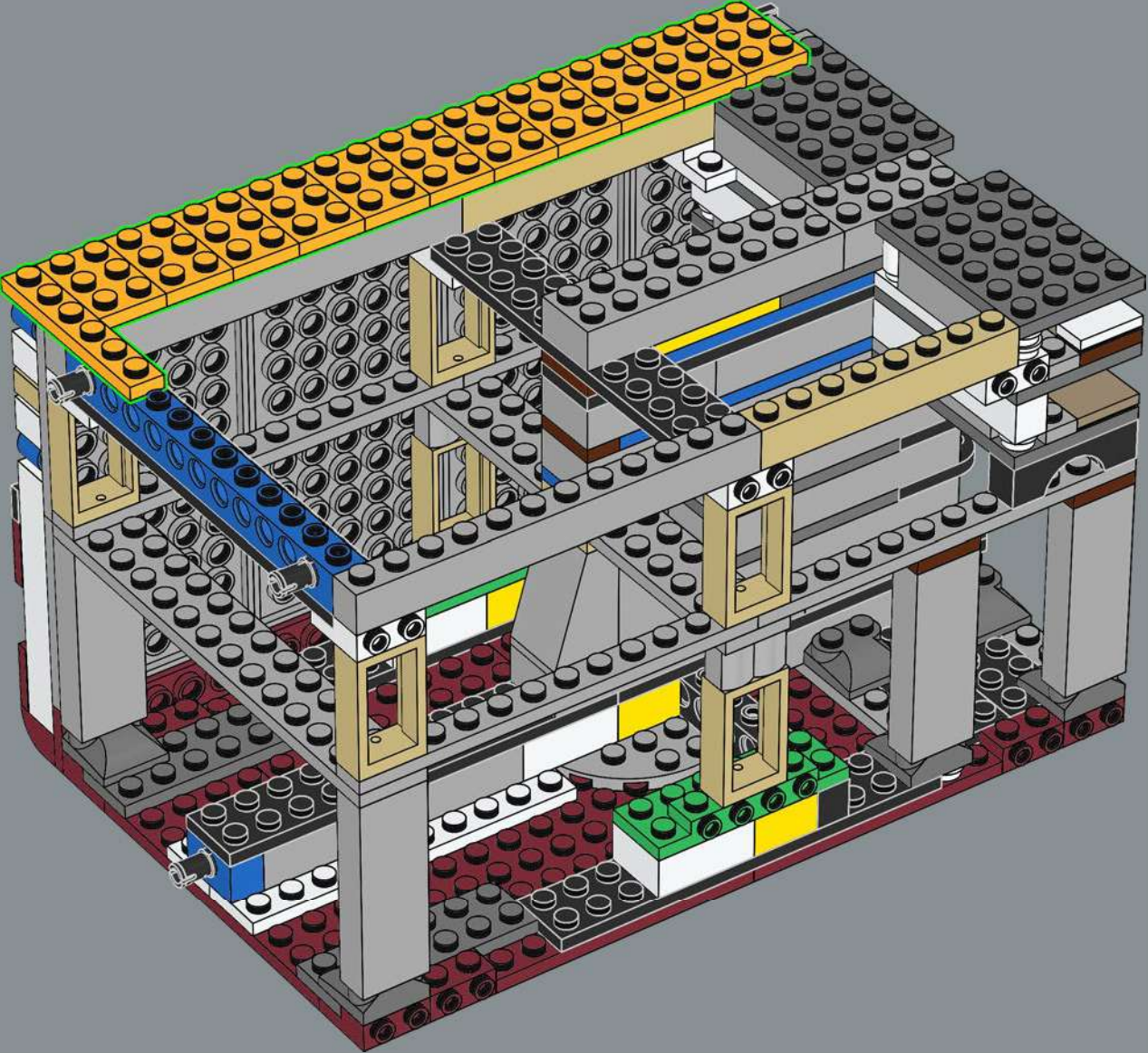

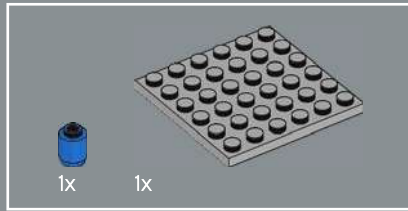
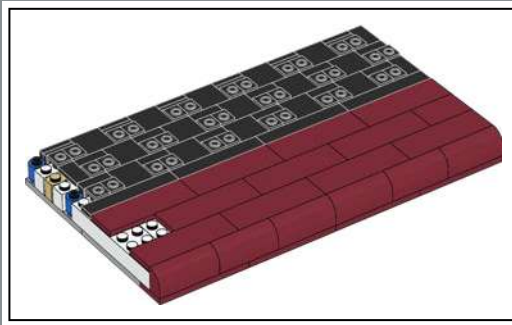
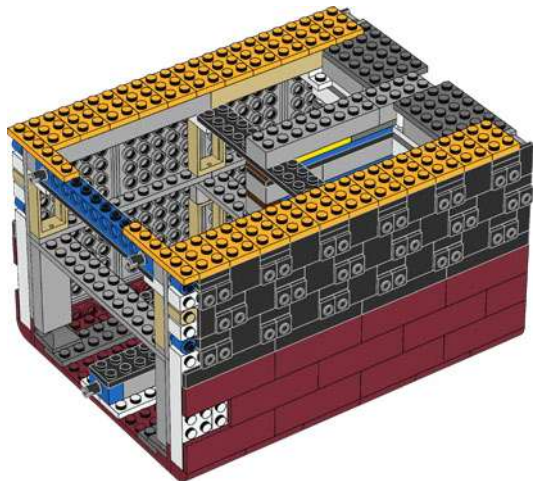
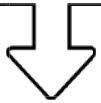

183

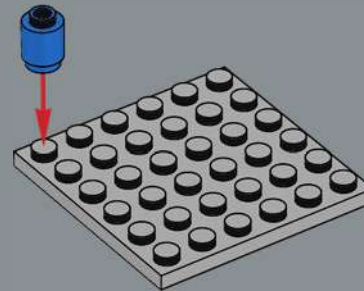

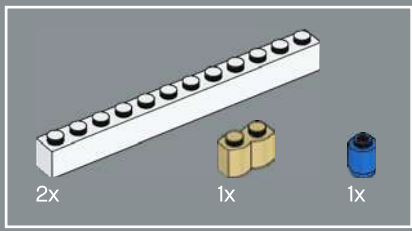

184

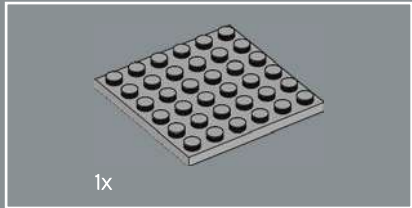
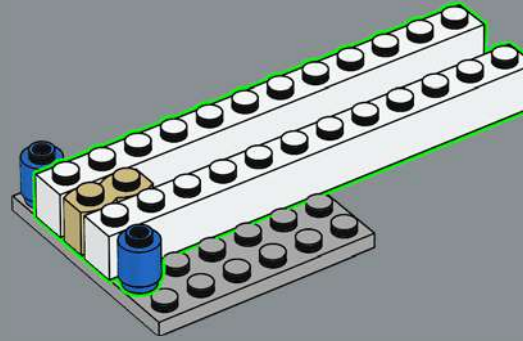

185

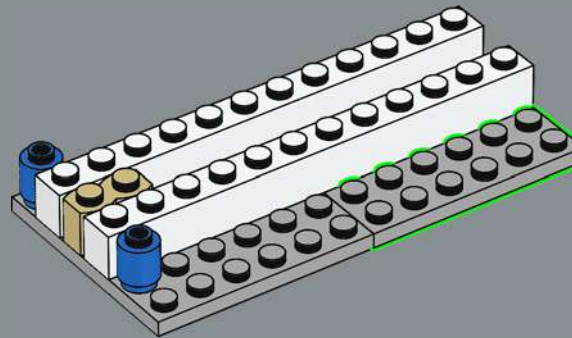

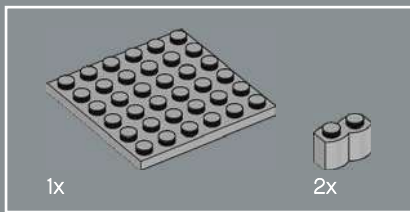

186

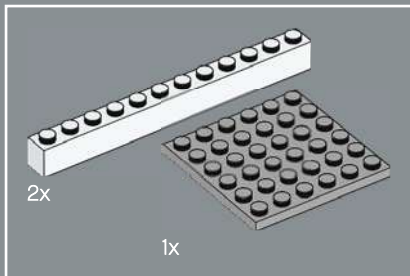
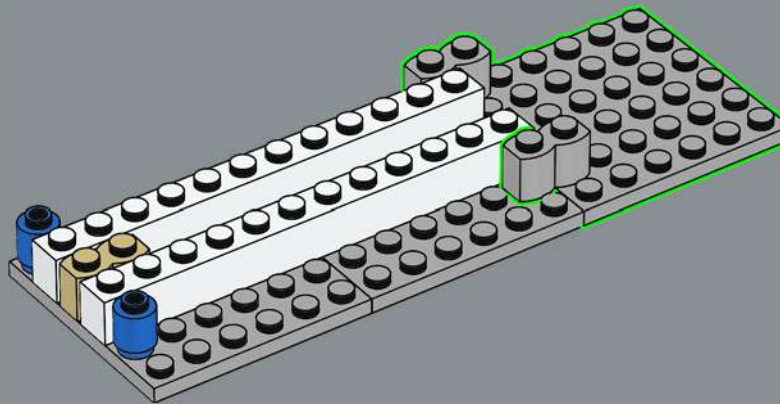

187

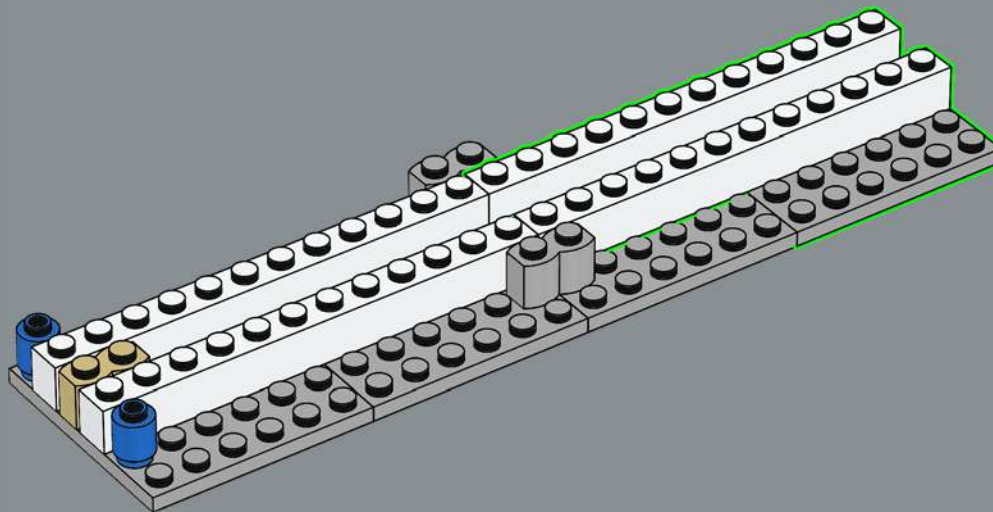



188

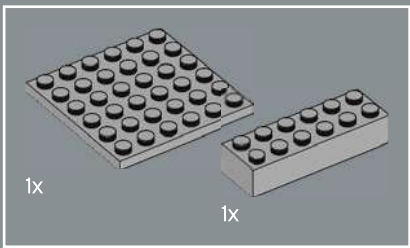
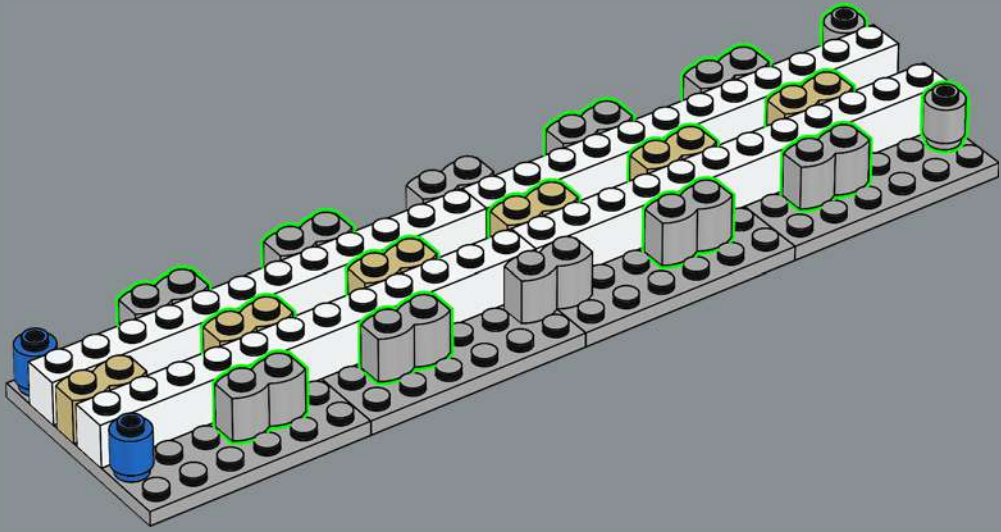

189

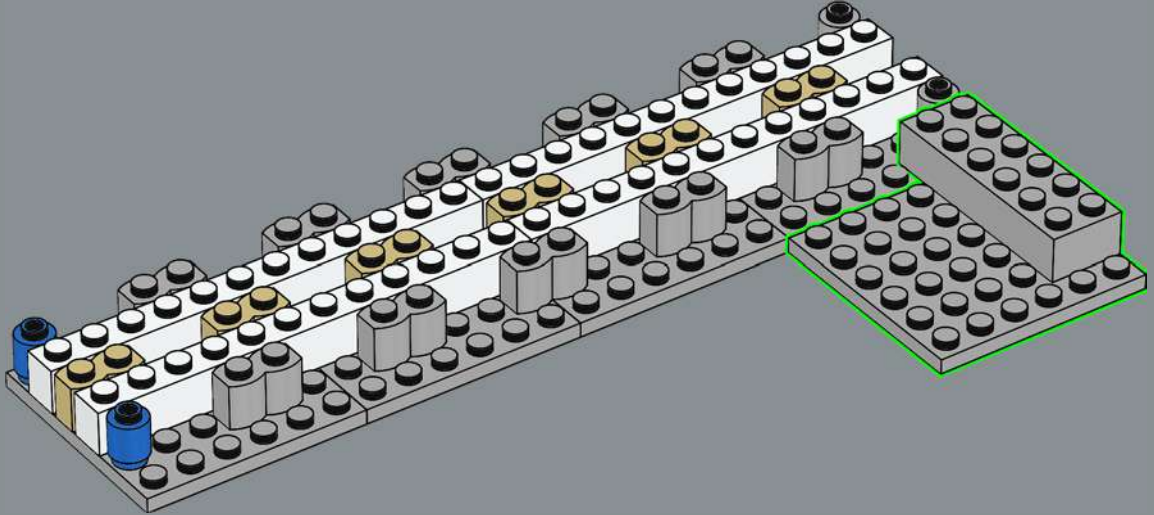

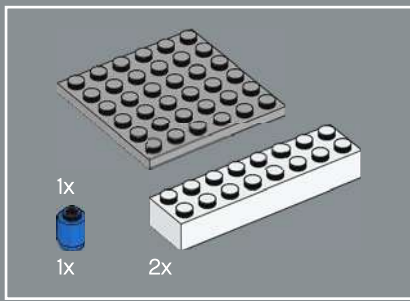

190

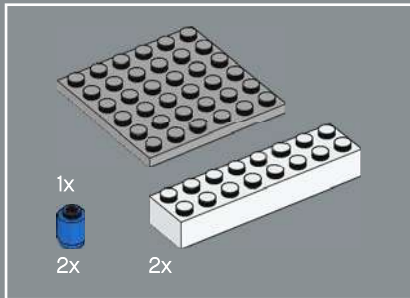
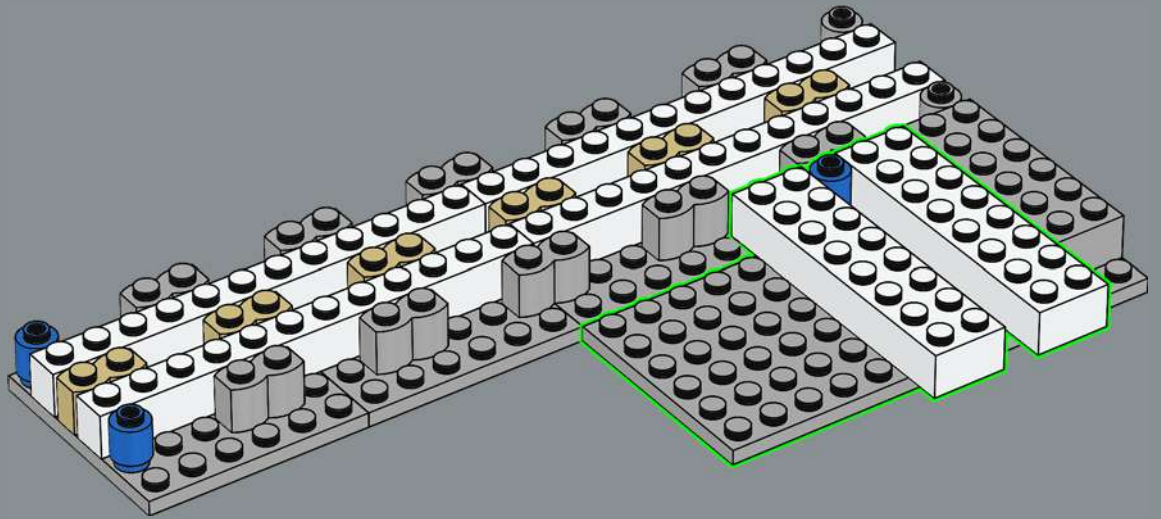

191

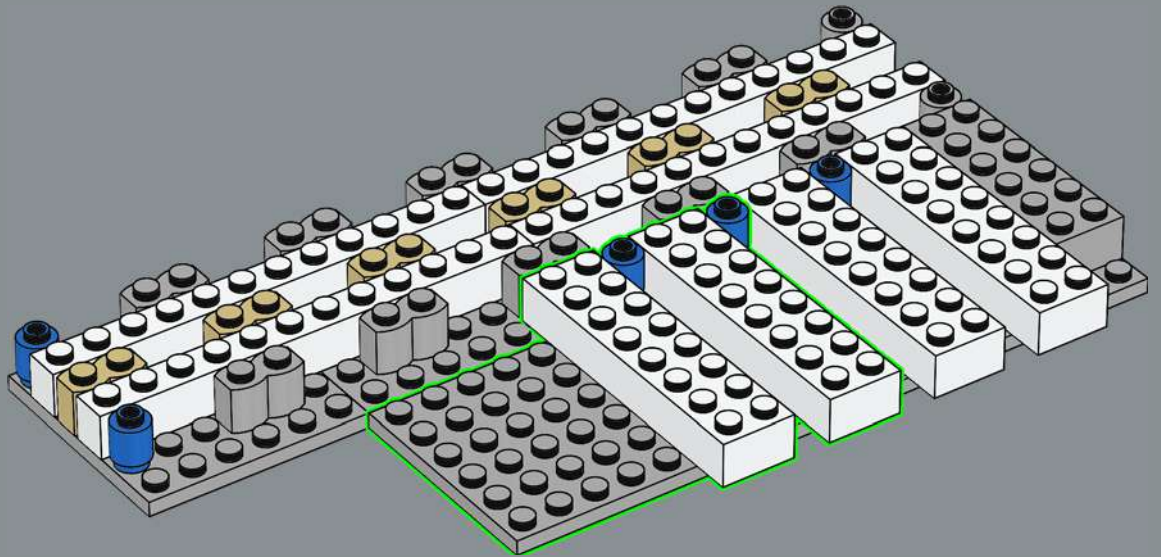

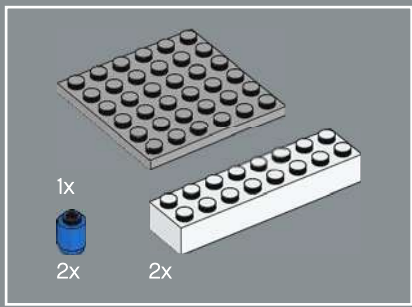

192

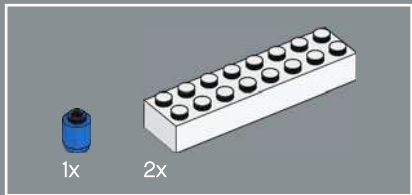
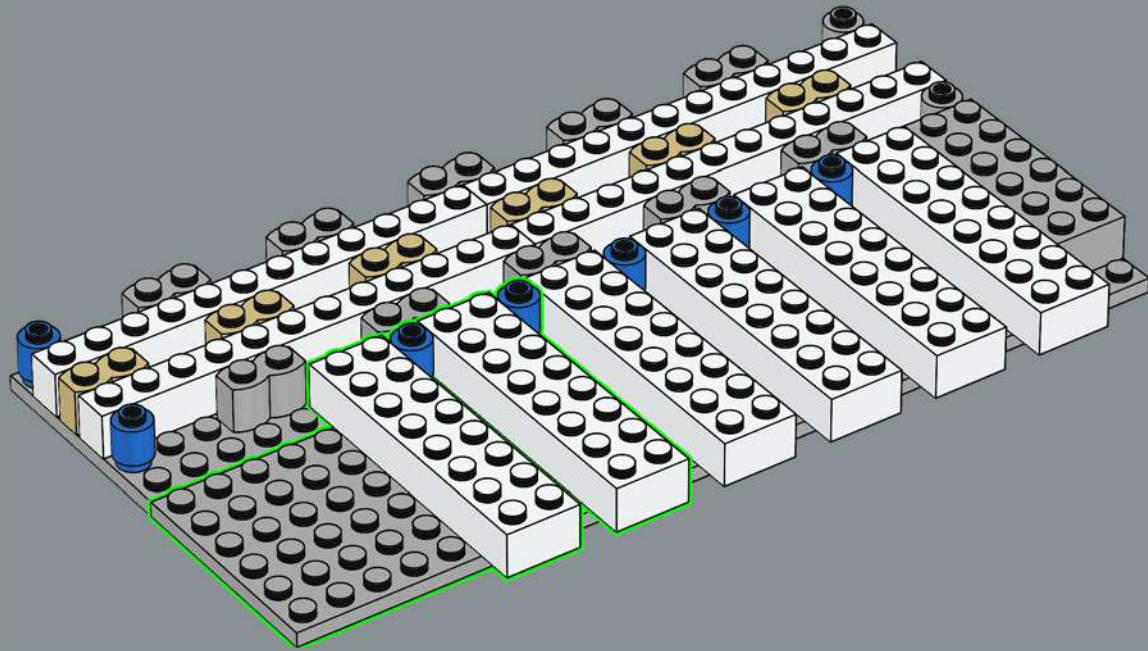

193

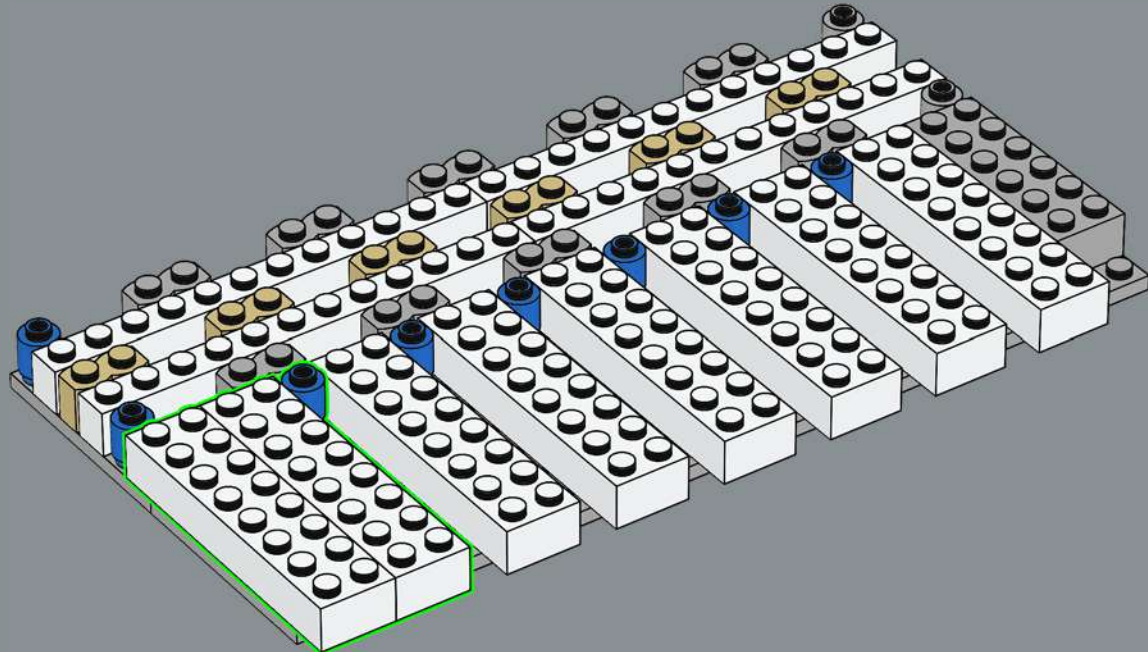

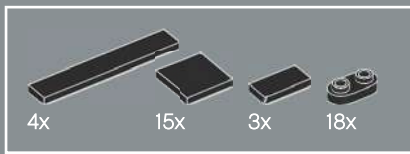

194

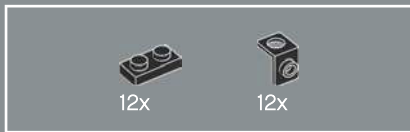
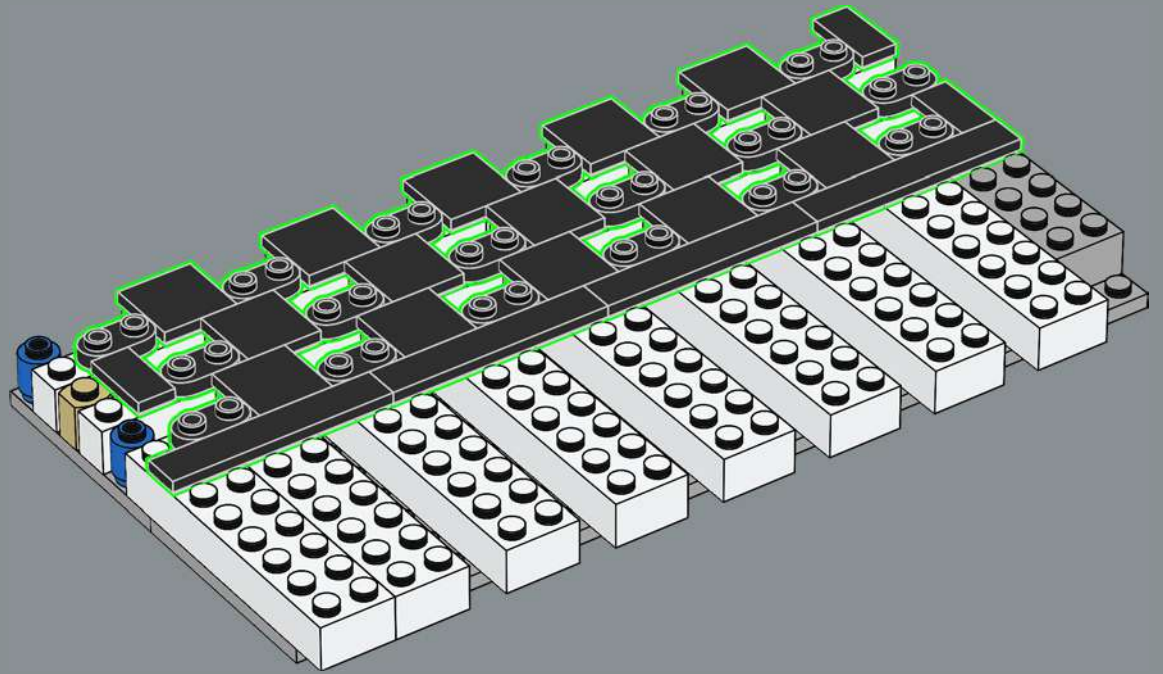

195

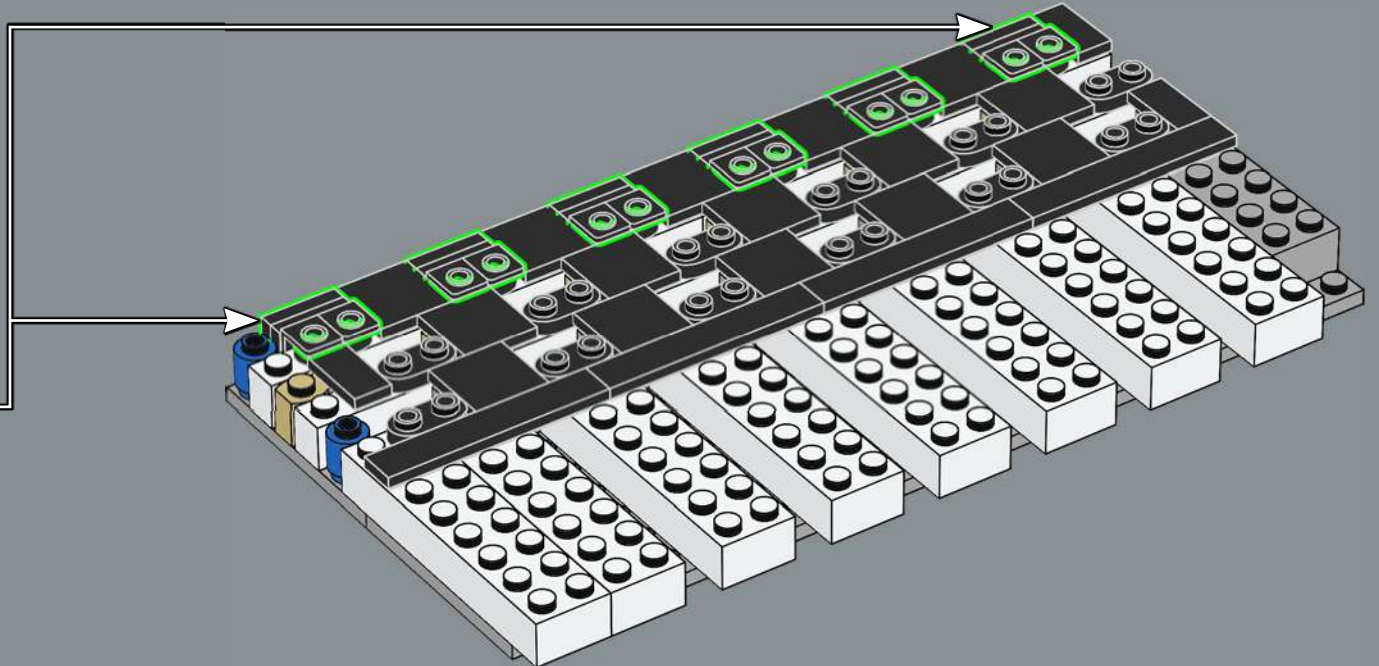
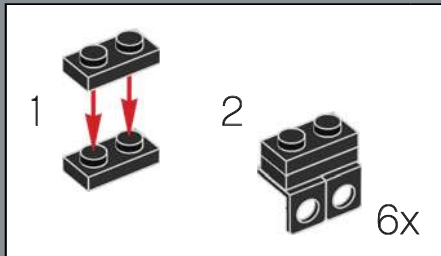



196

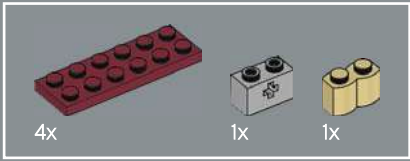
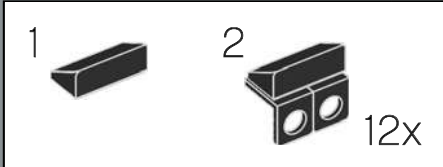
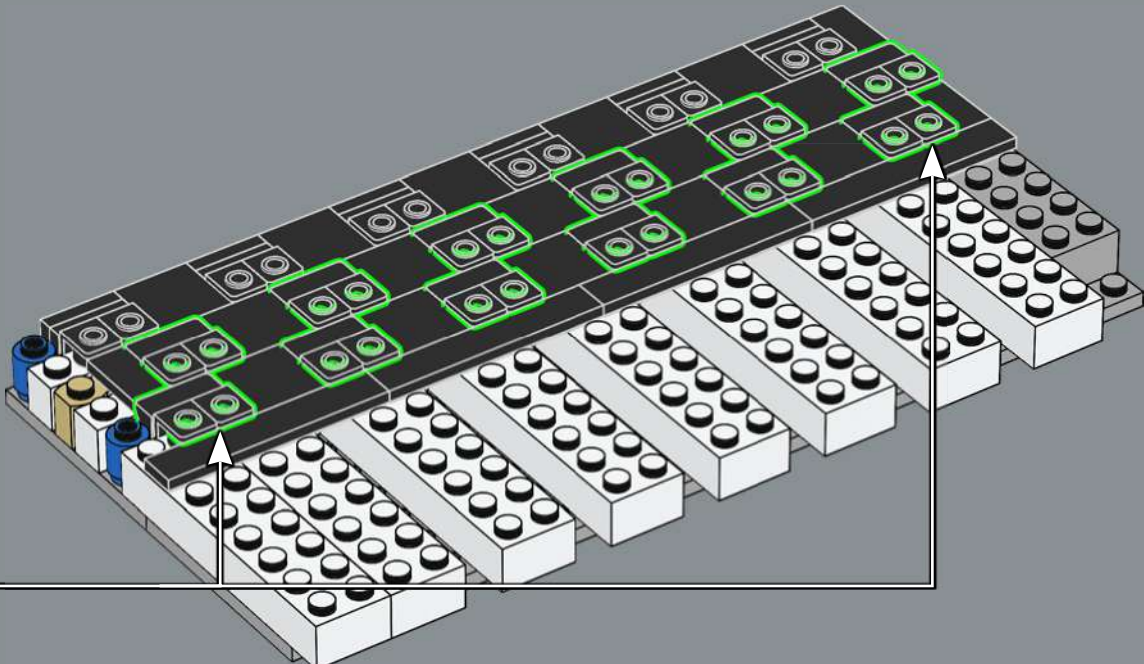

197

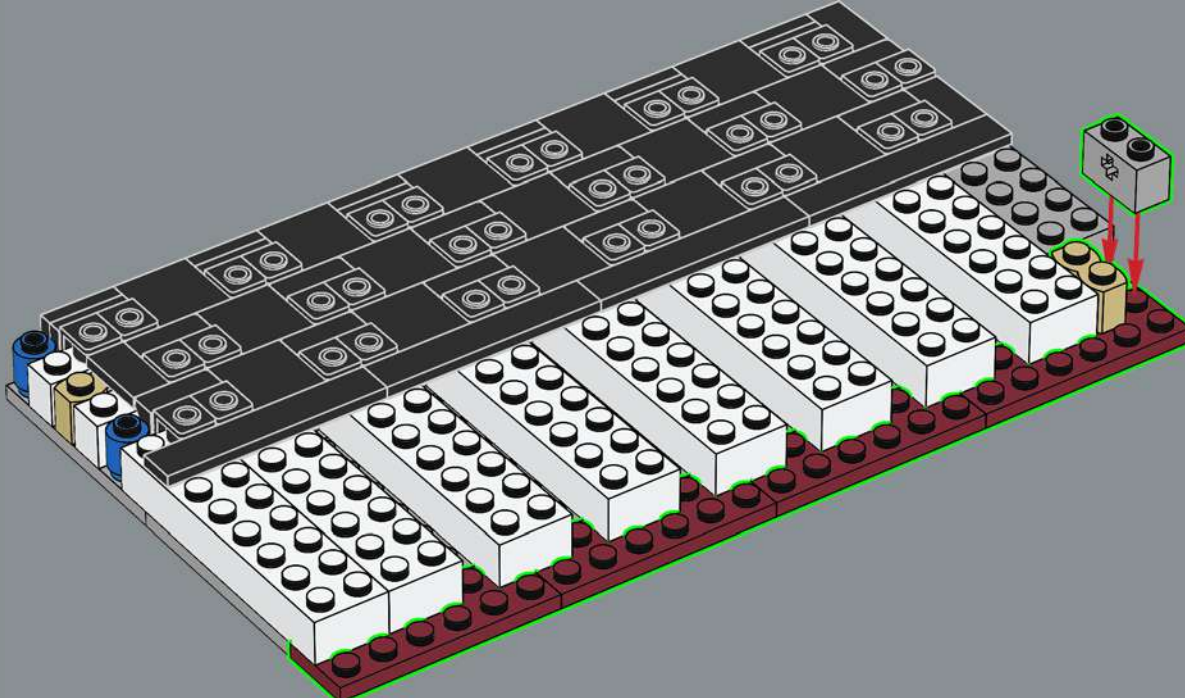

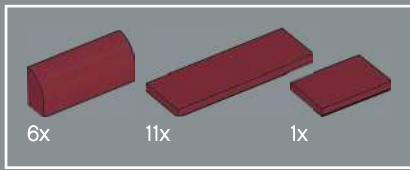

198

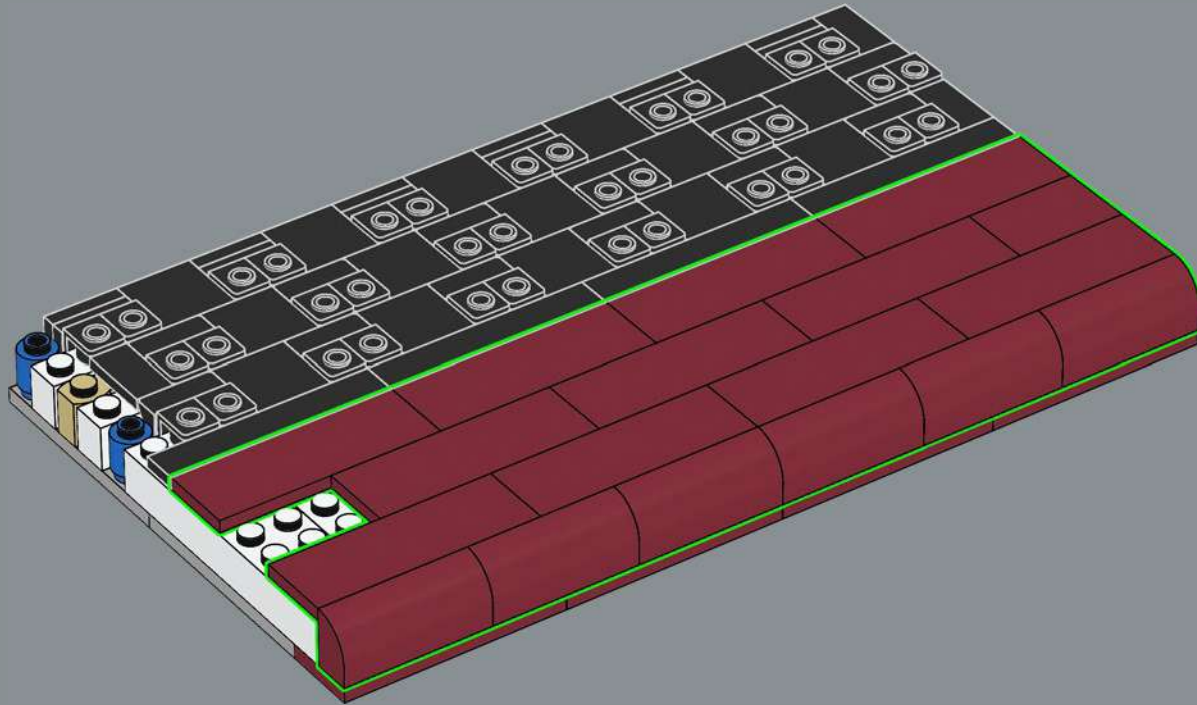

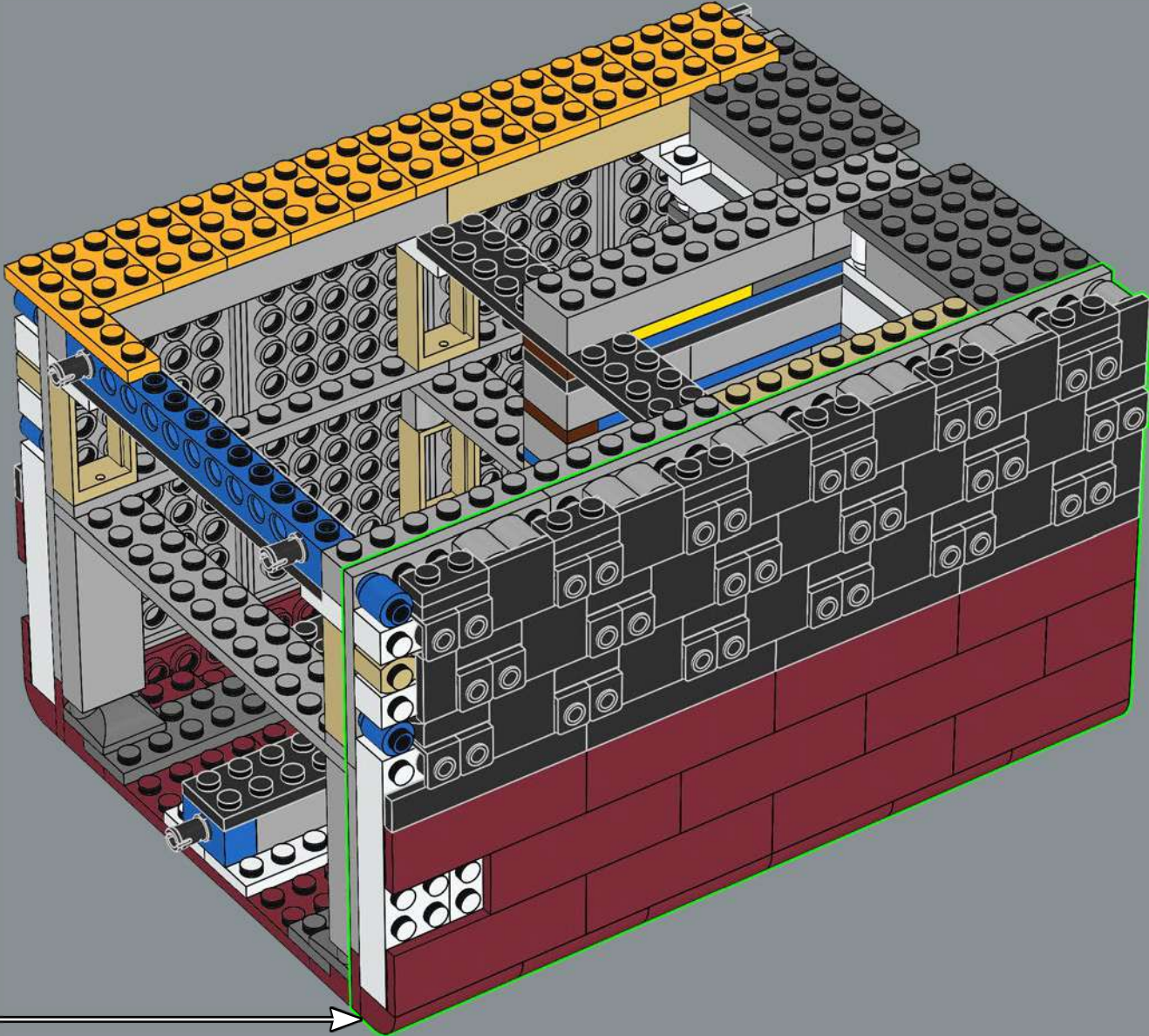

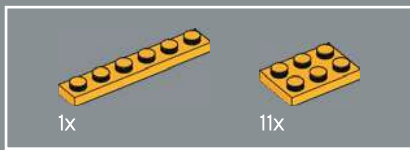

200

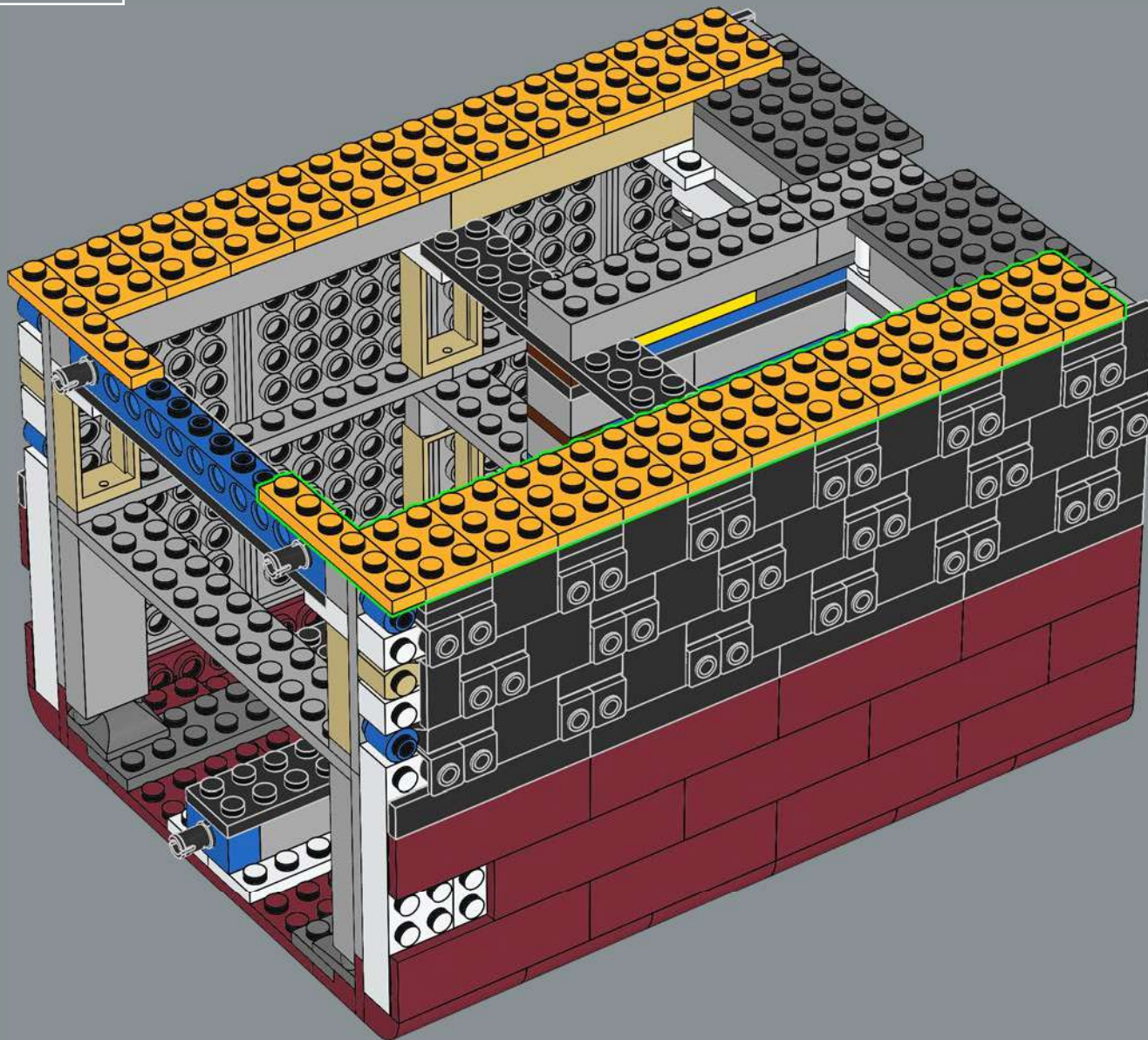

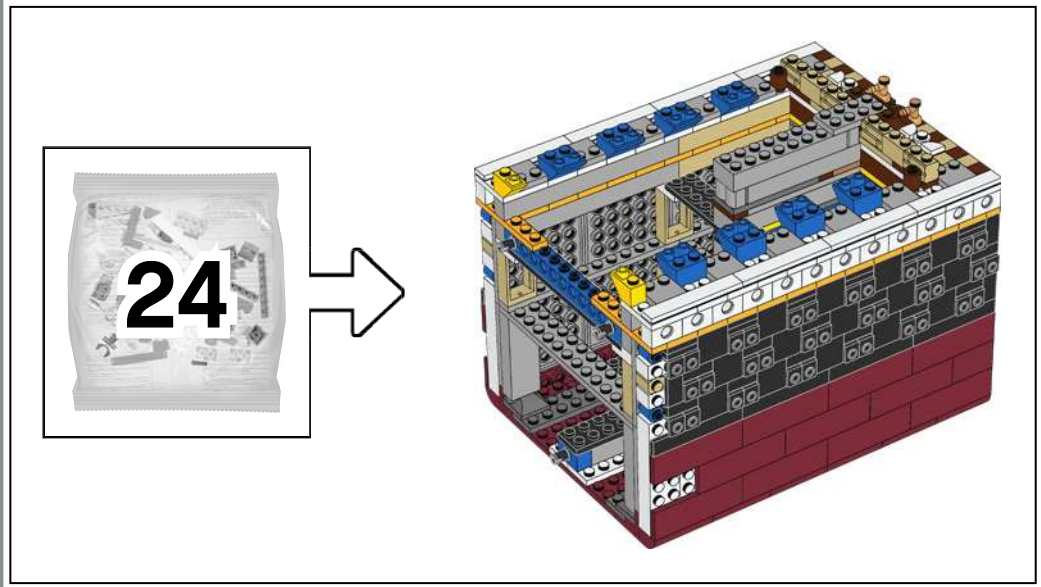

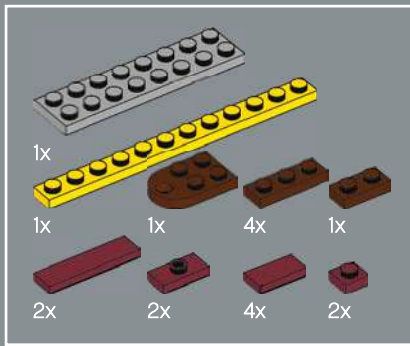

201

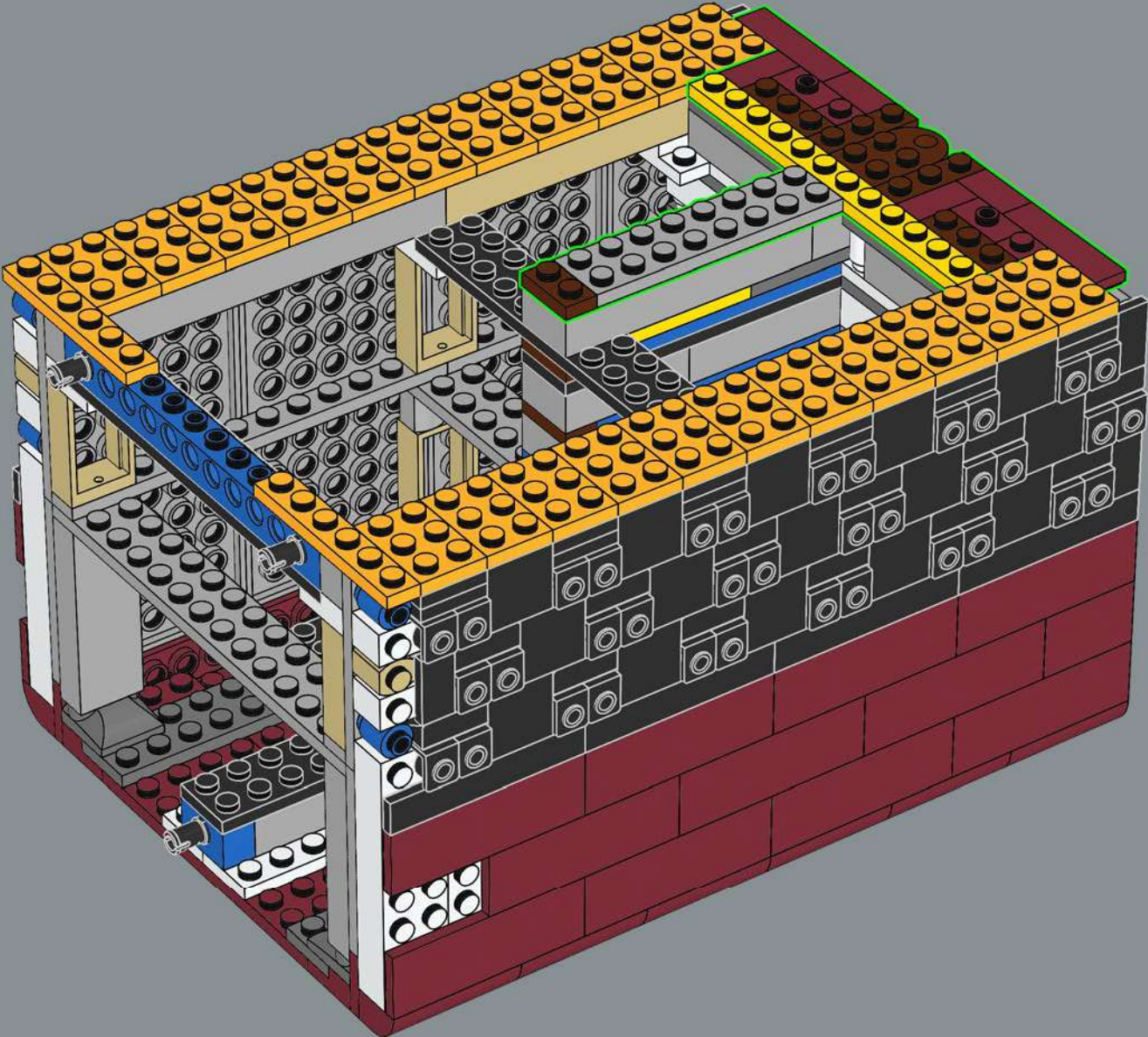

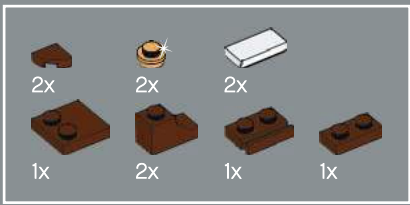

202

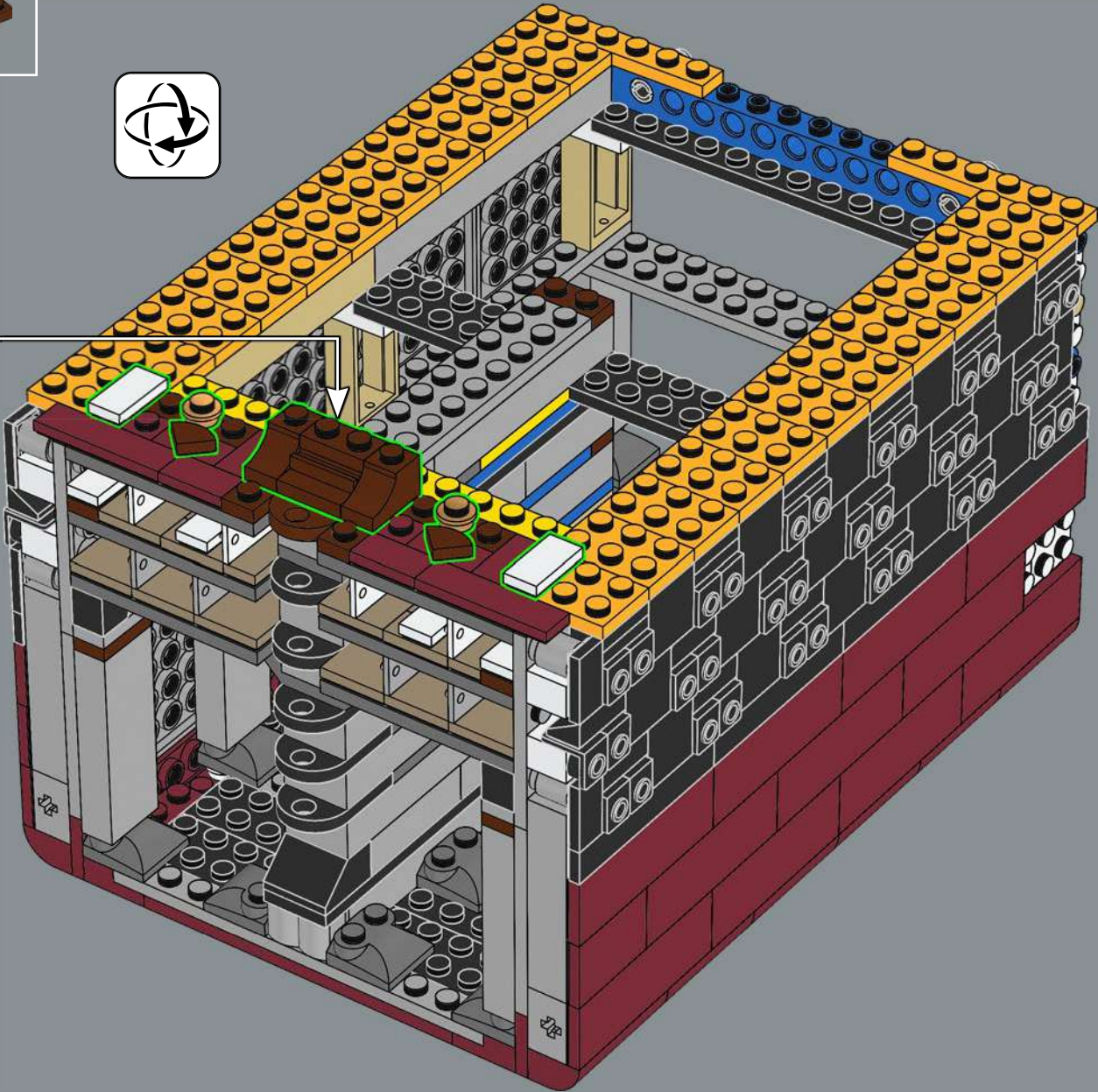
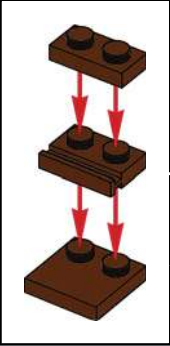

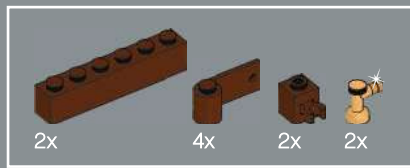

203

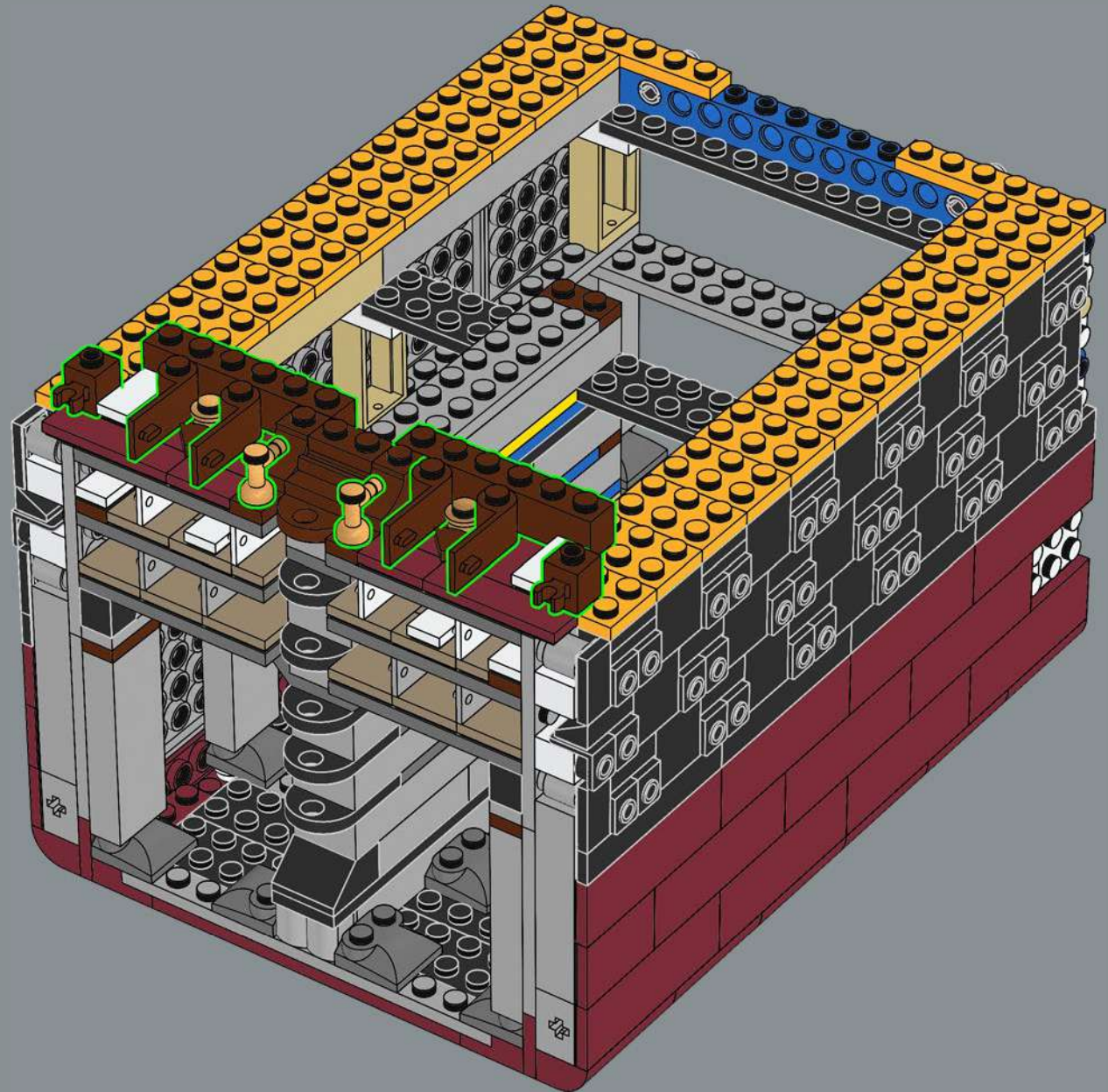

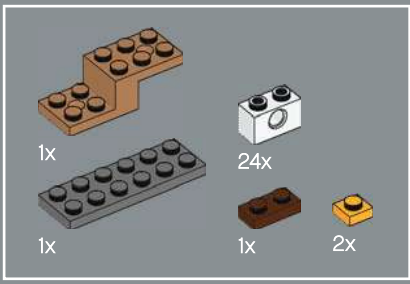

204

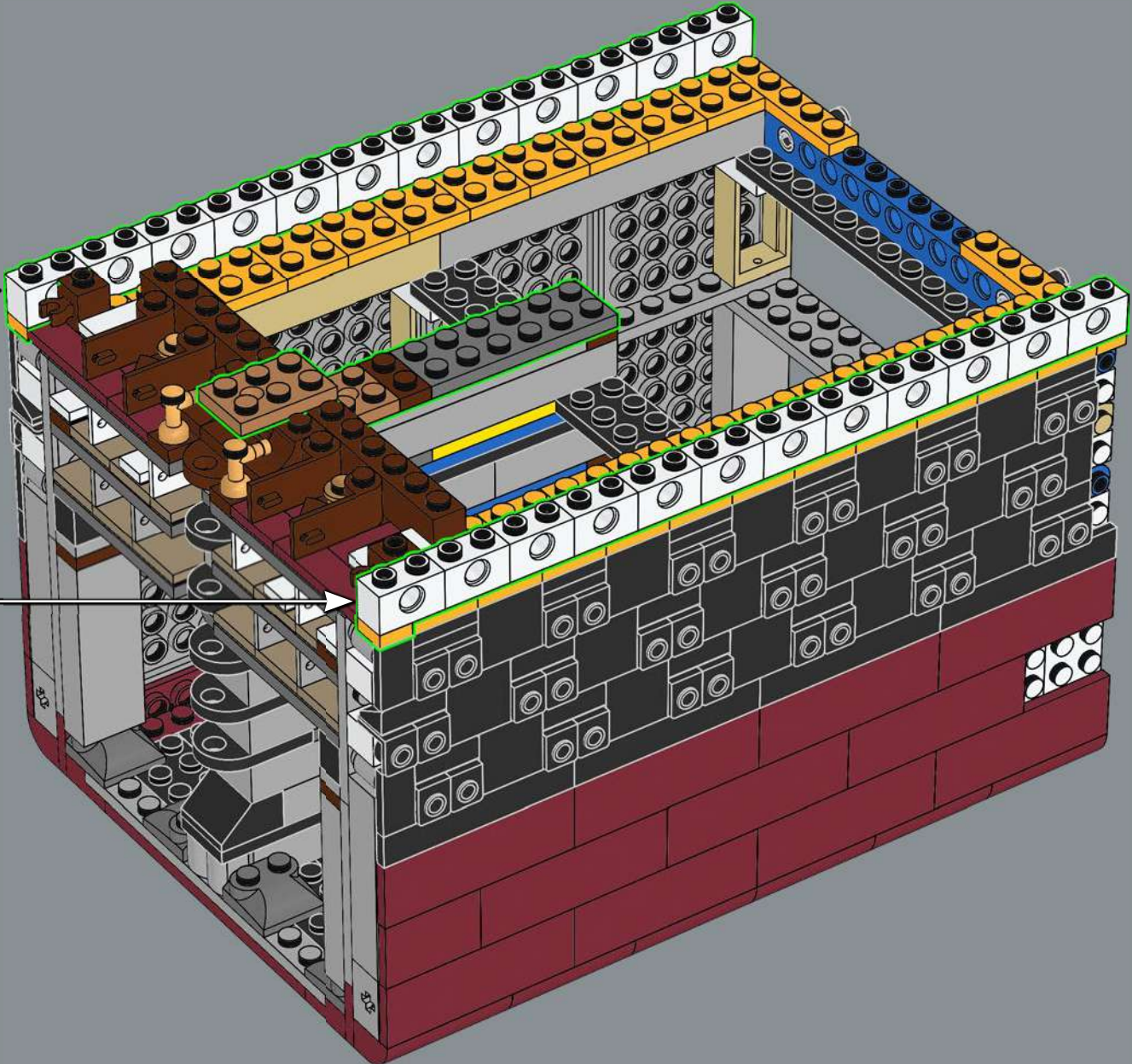
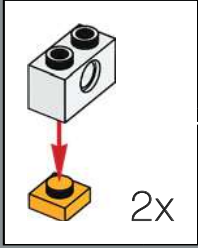

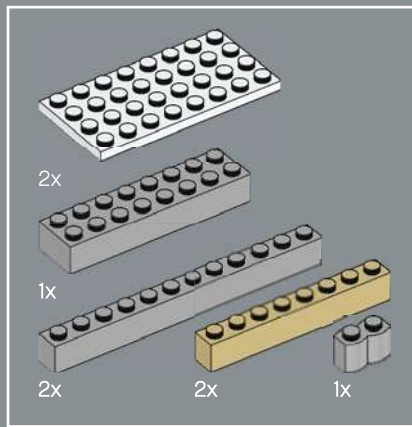

205

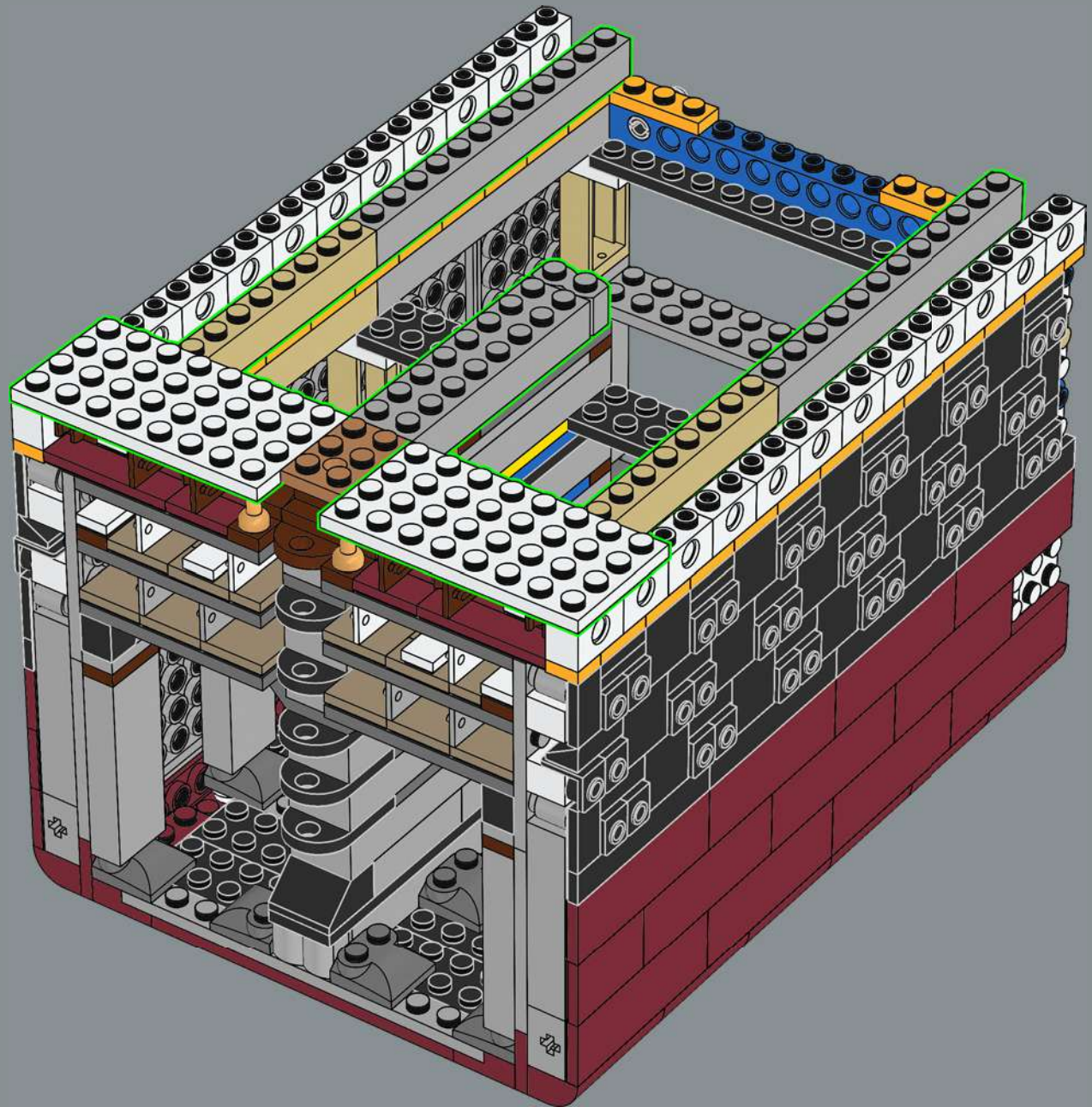

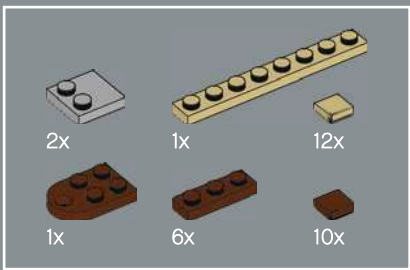

206

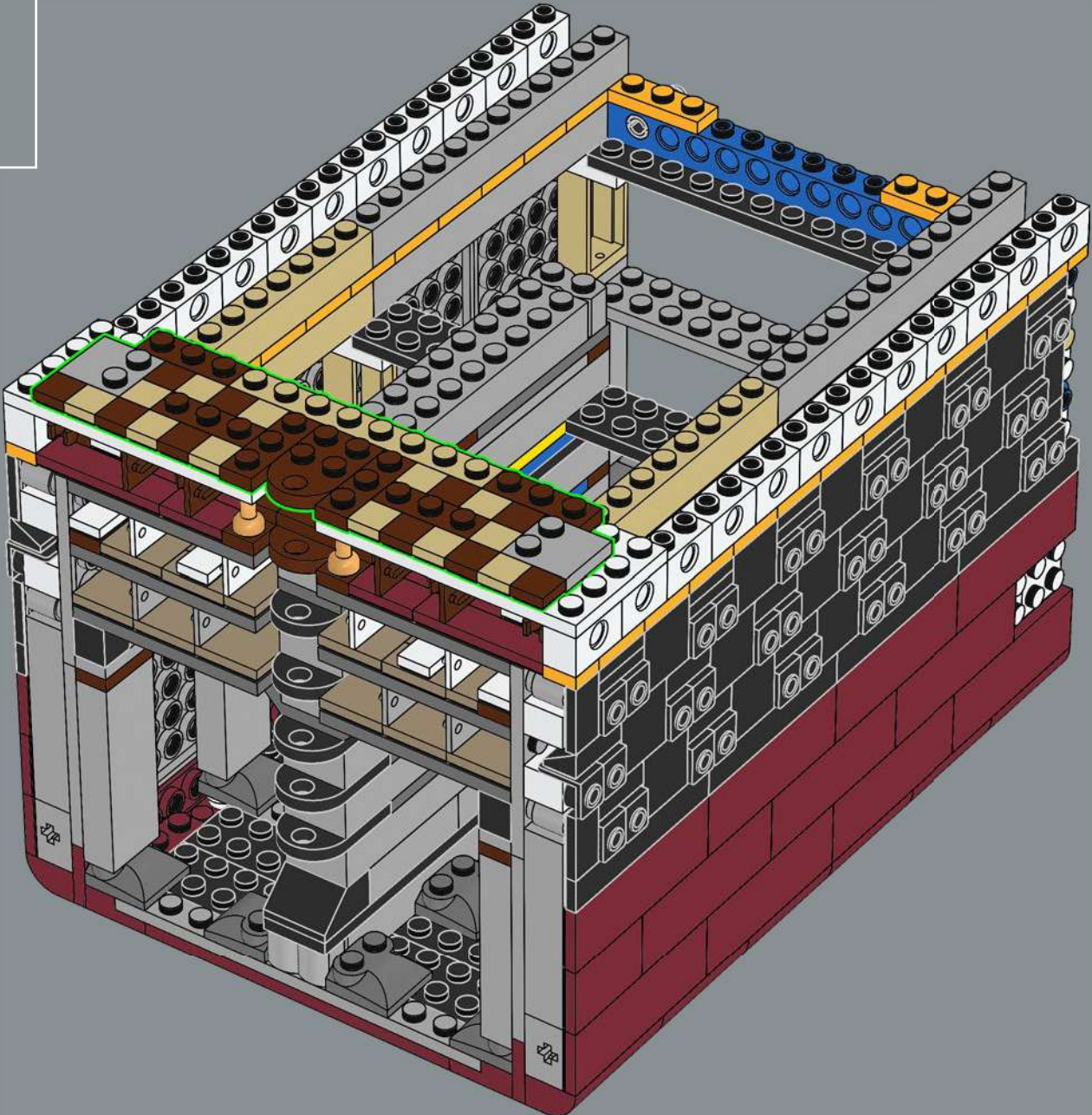



207

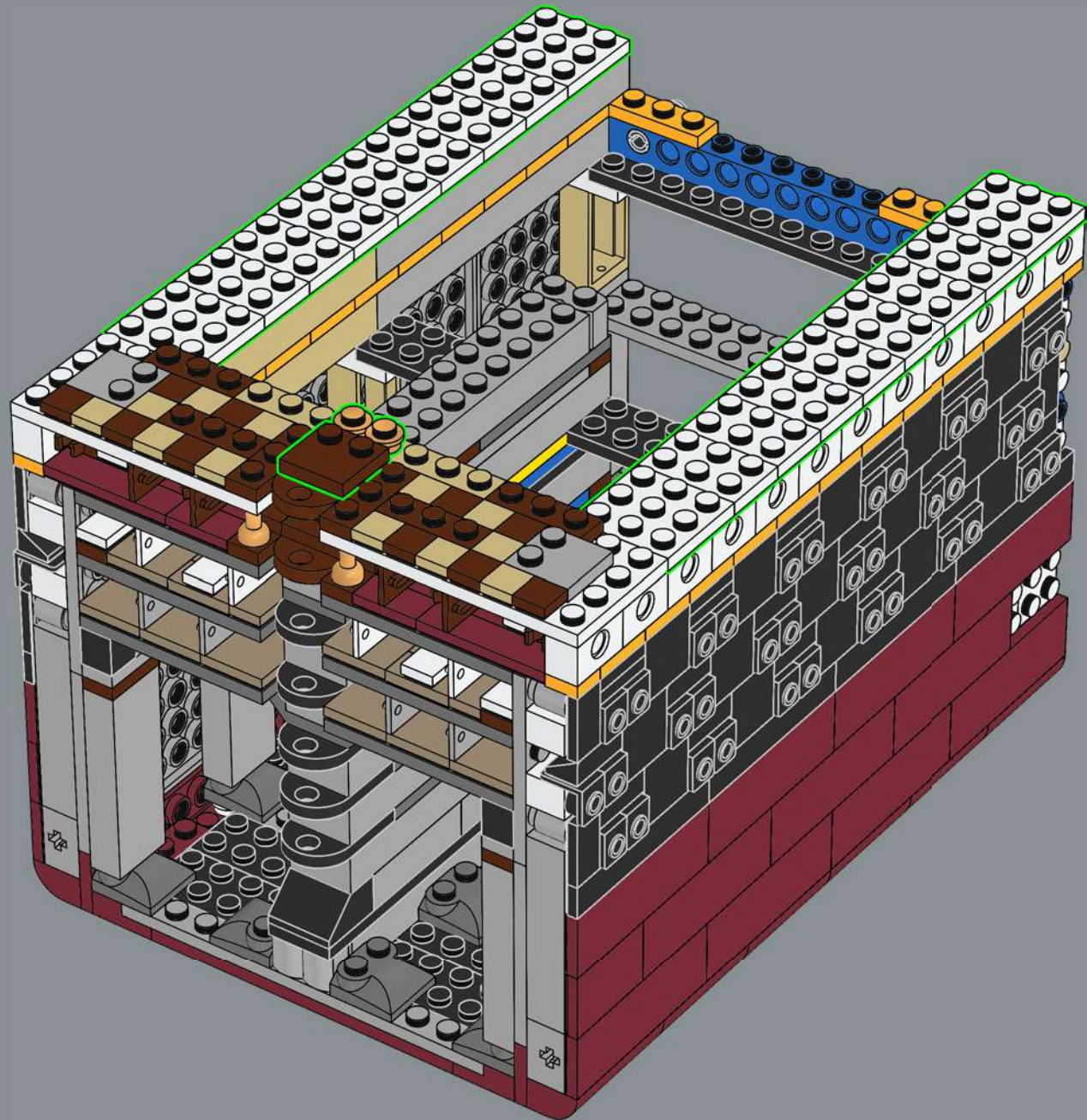

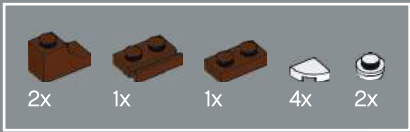

208



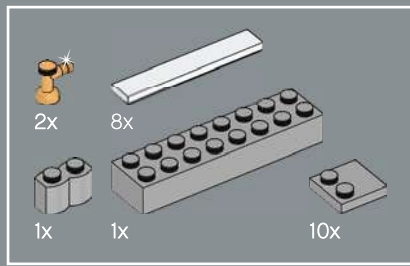

209

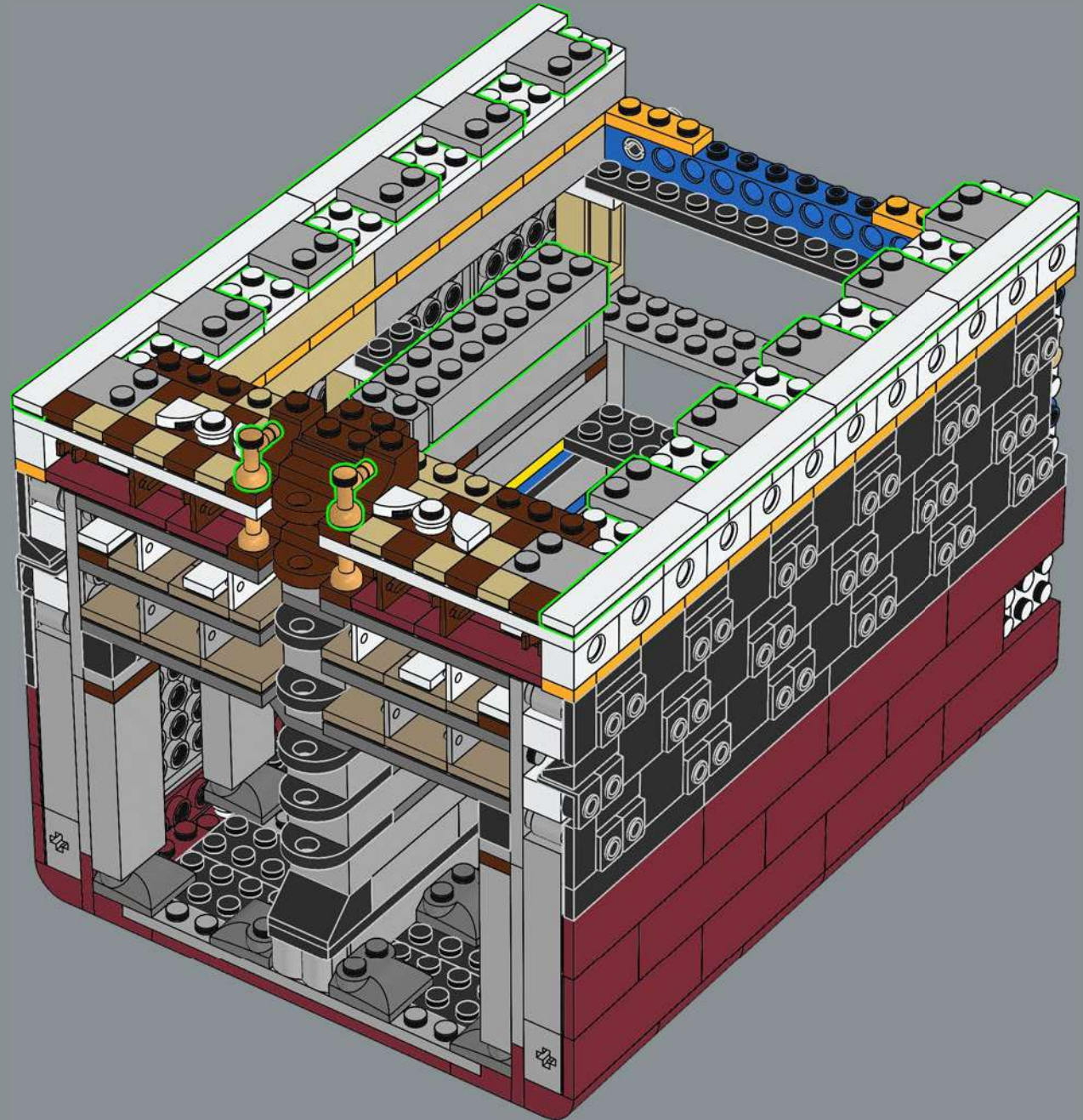

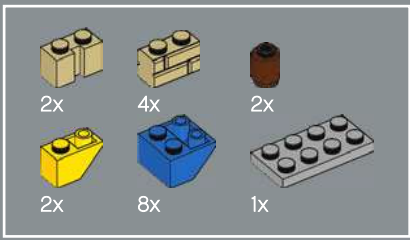

210

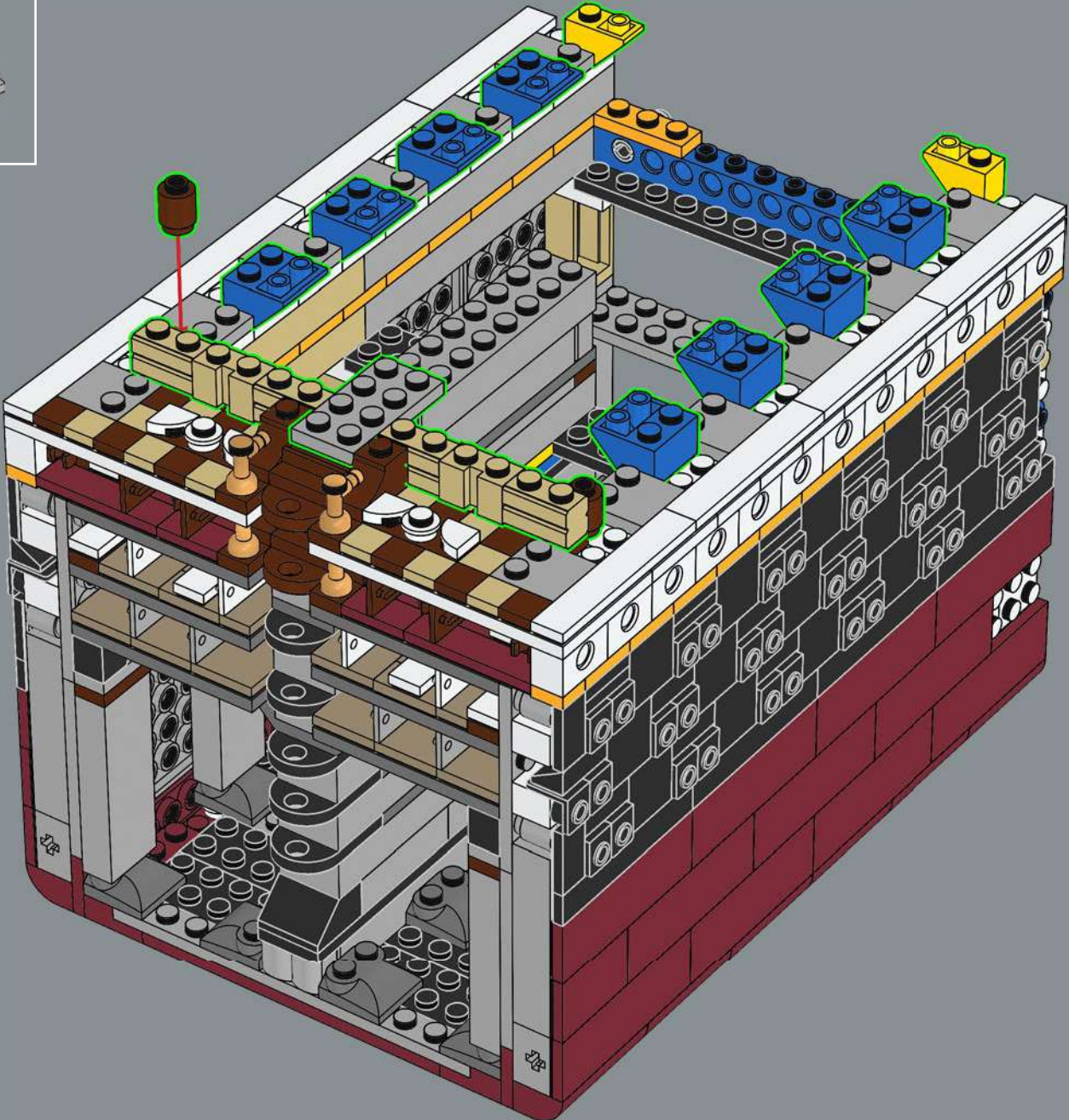

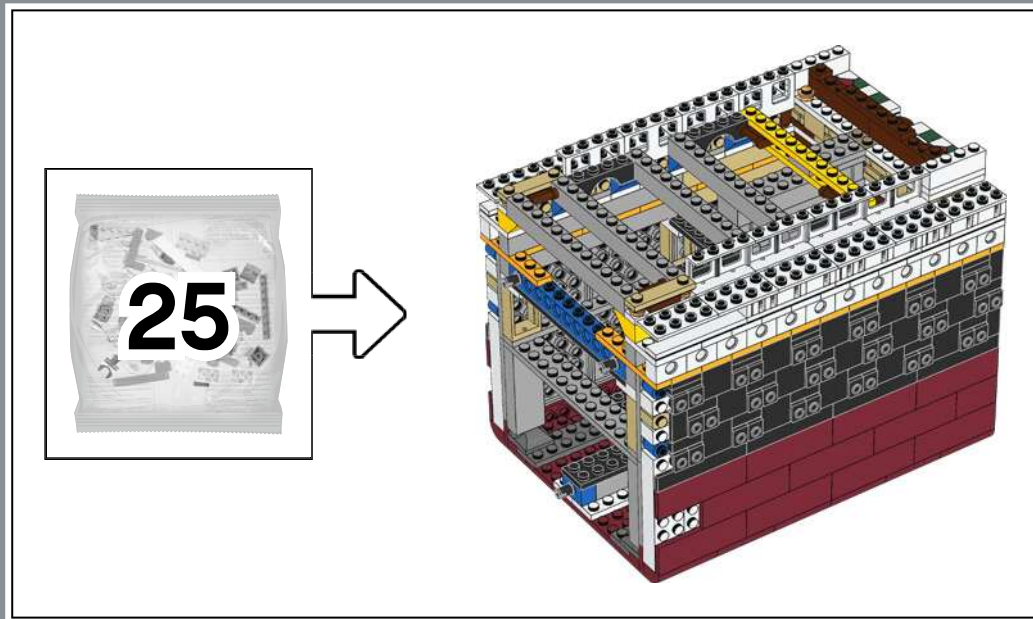



211

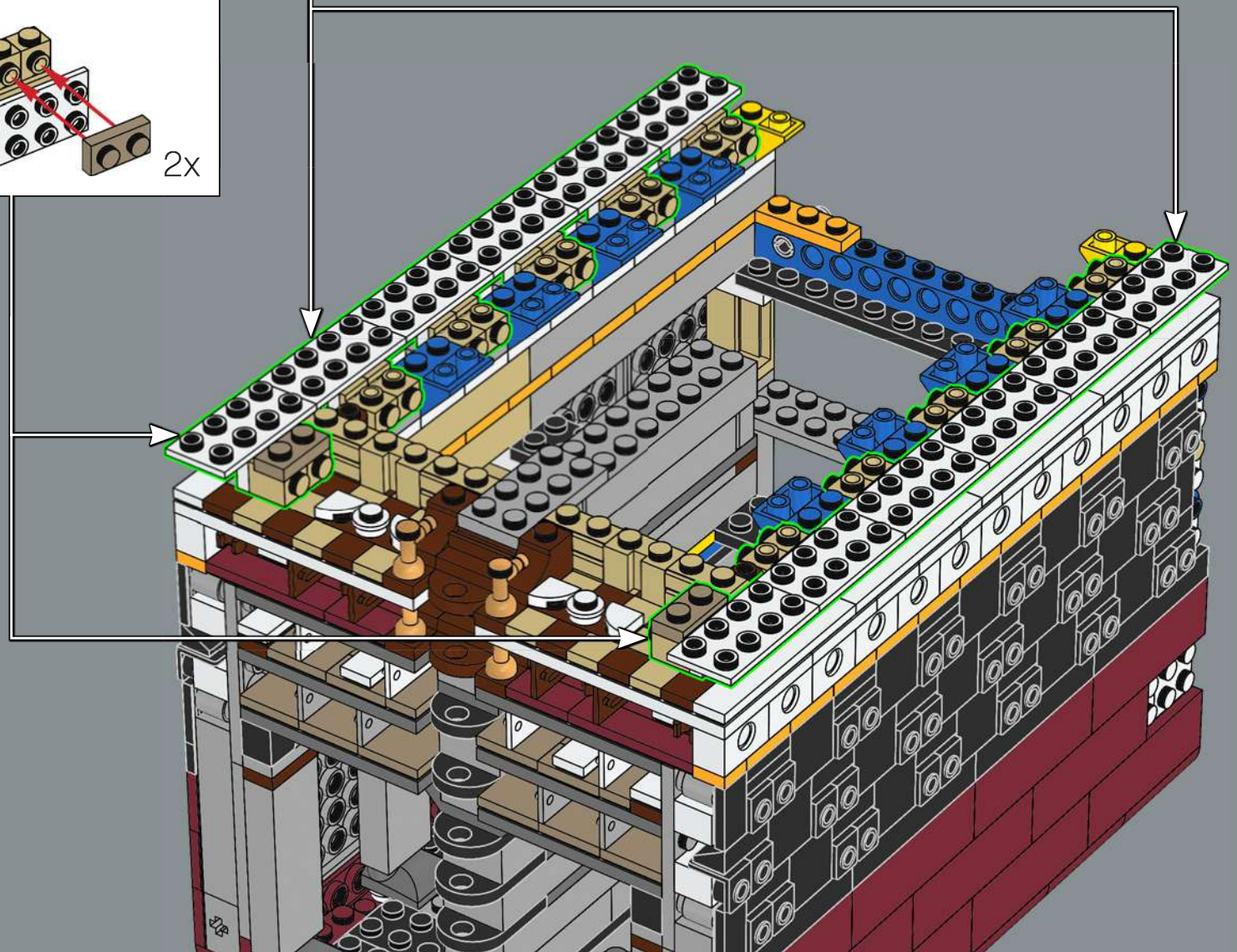
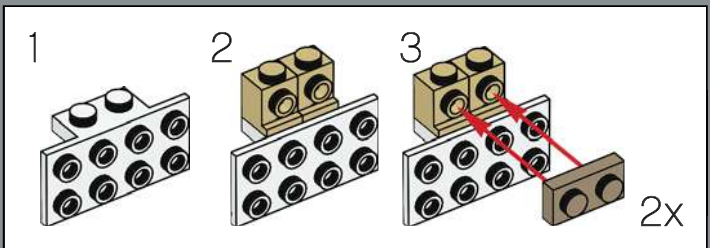
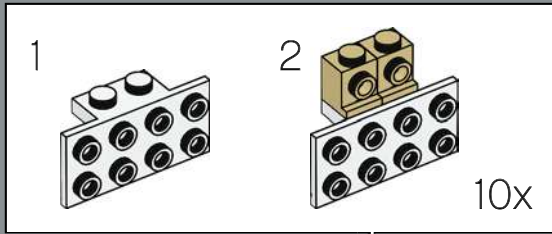

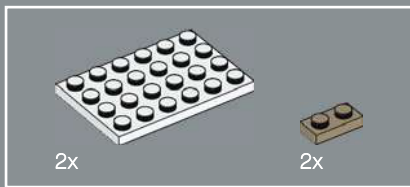

212

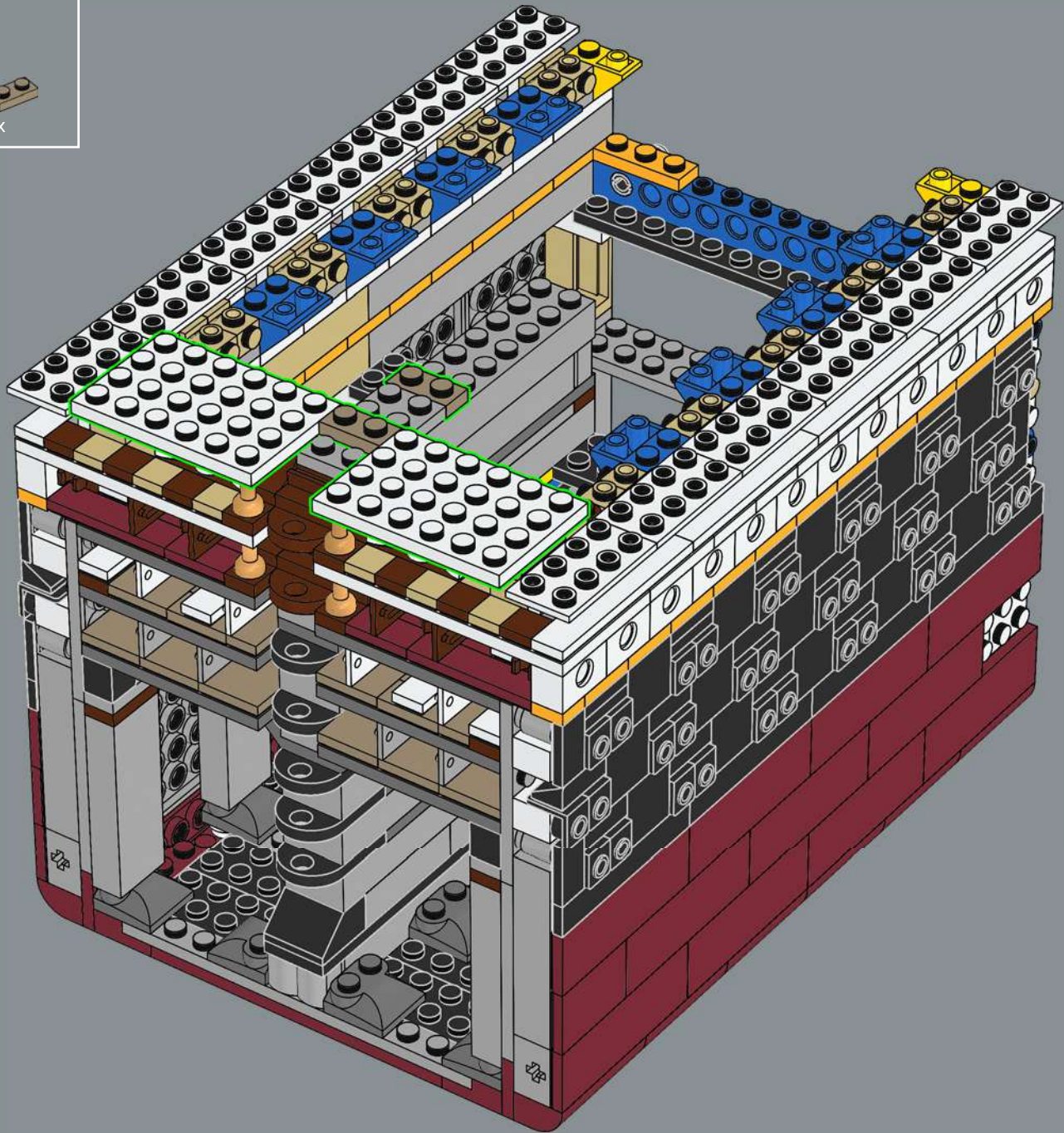

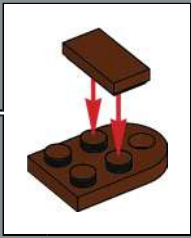
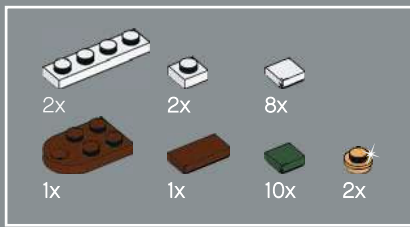

213

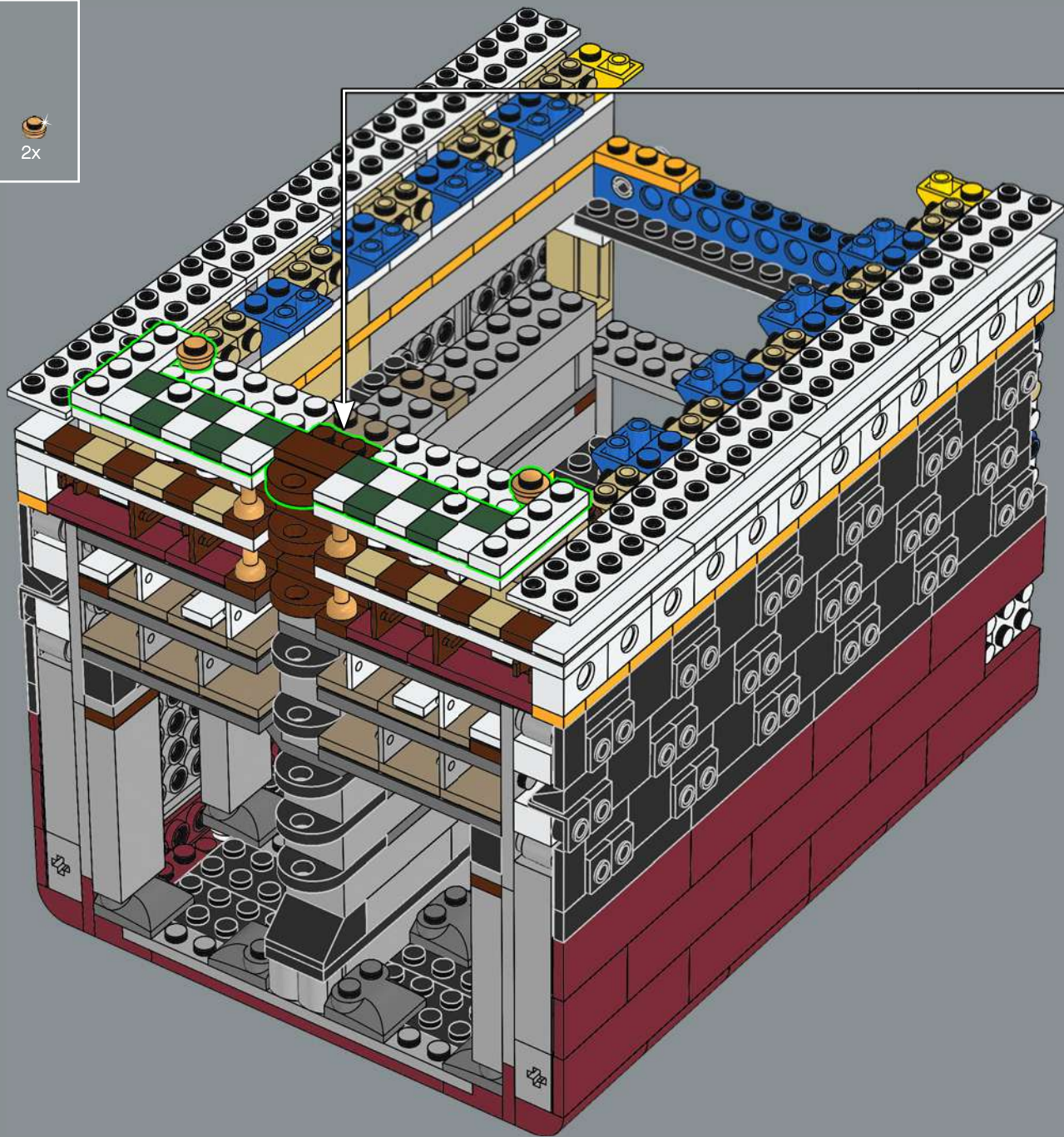

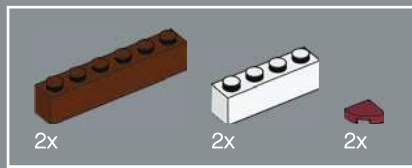

214

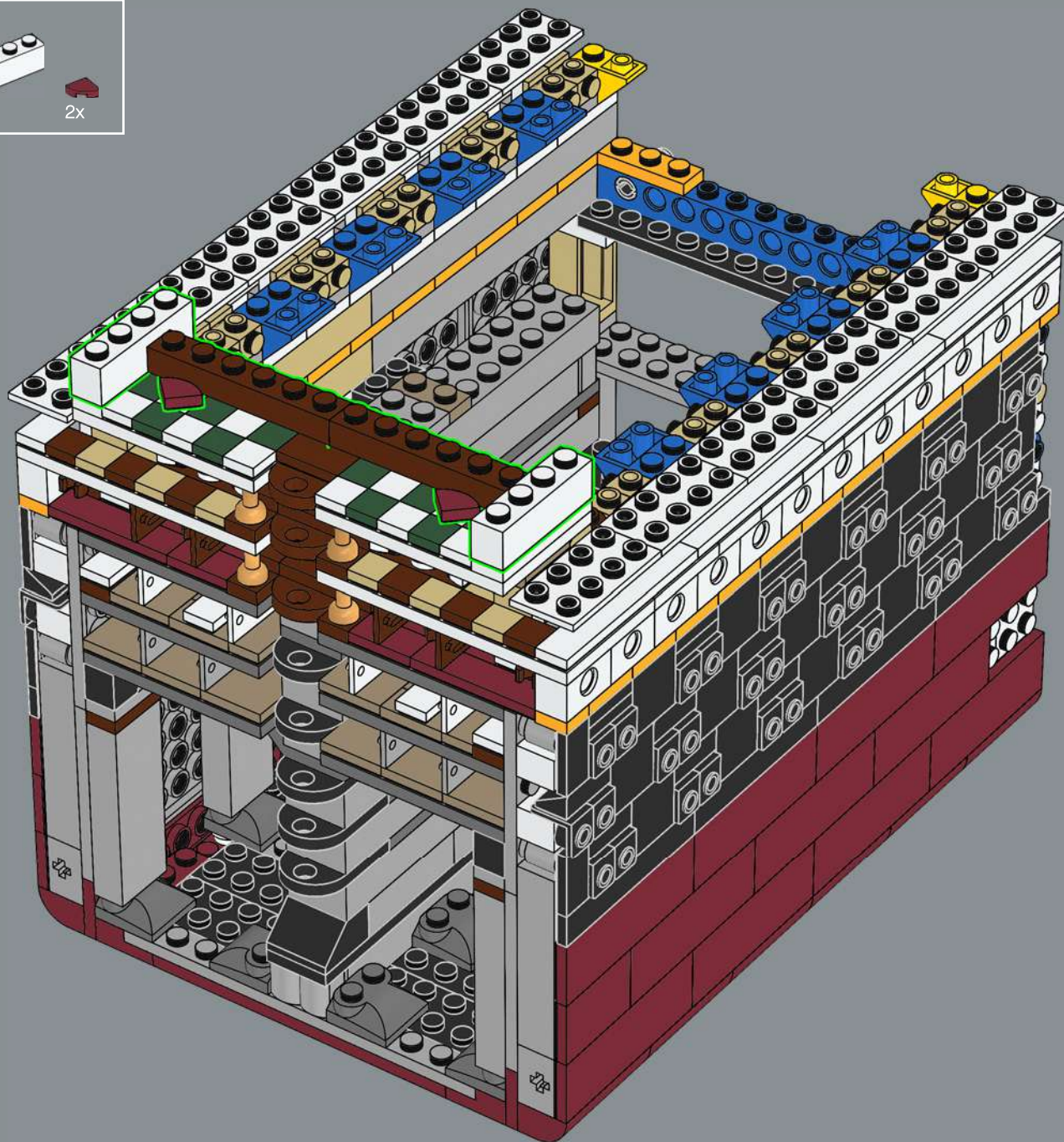

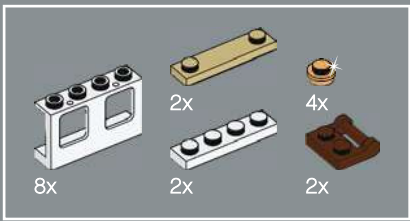

215

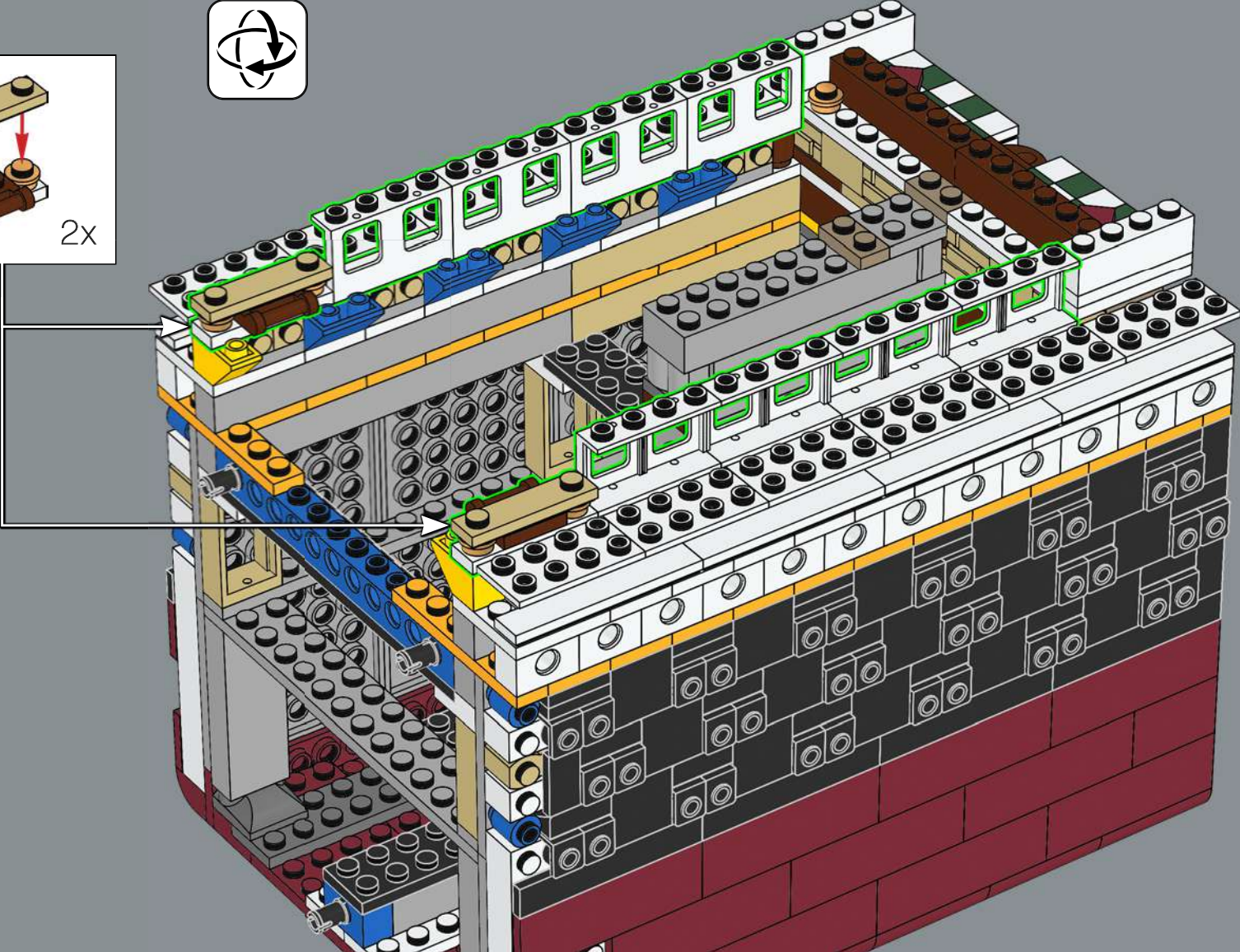
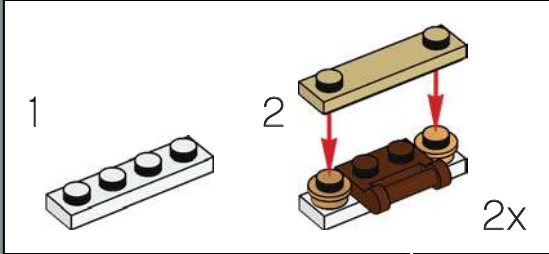

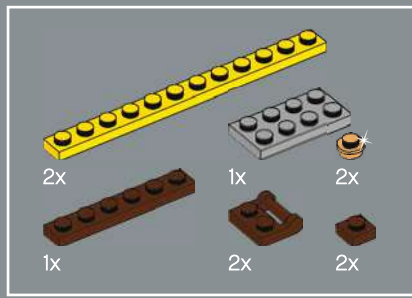

216

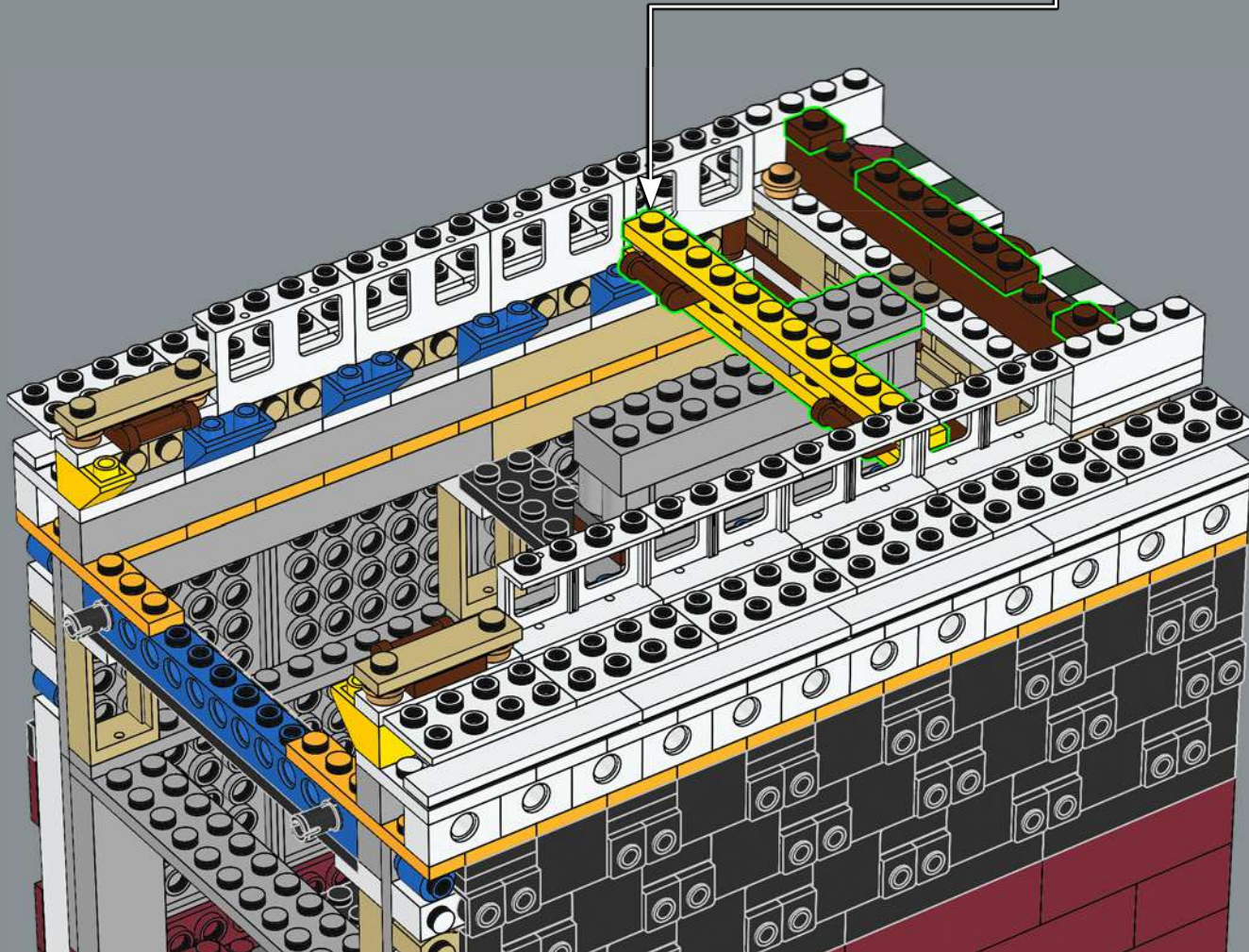
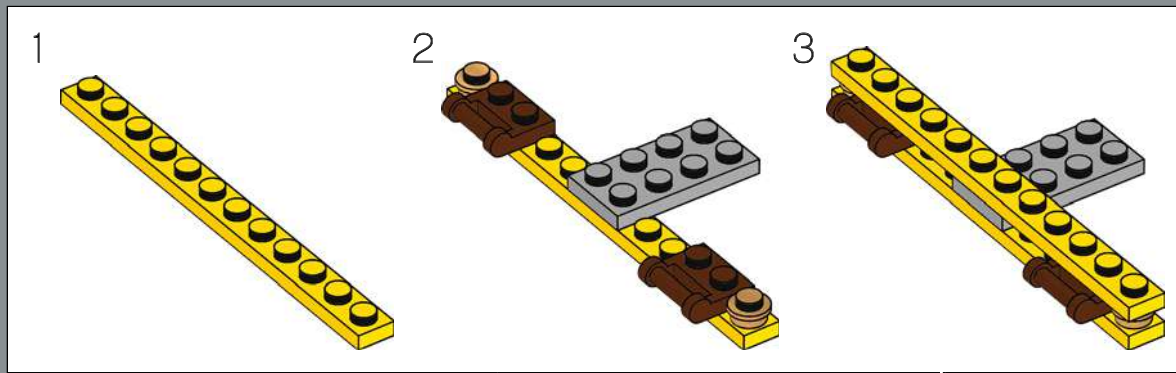

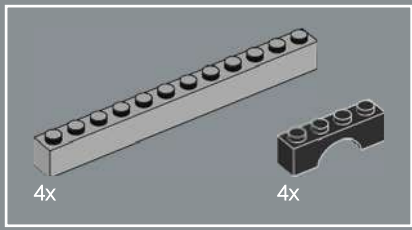

217

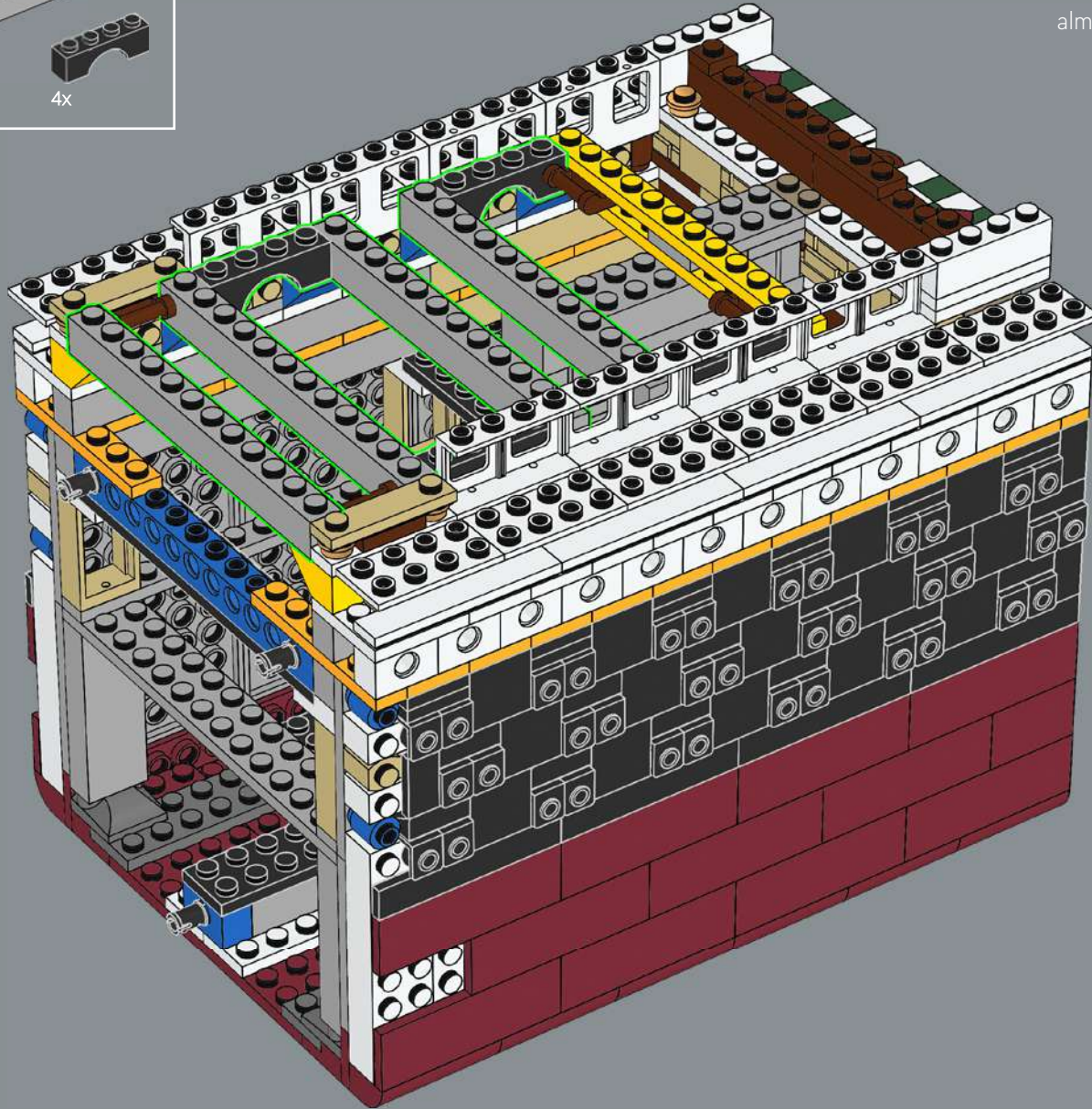

The *Titanic* and *Olympic* ships cost £3 million (approx. 4.1 million US dollars) to build - almost £300 million (416.7 million US dollars) in today's money.

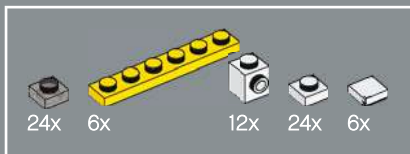

218

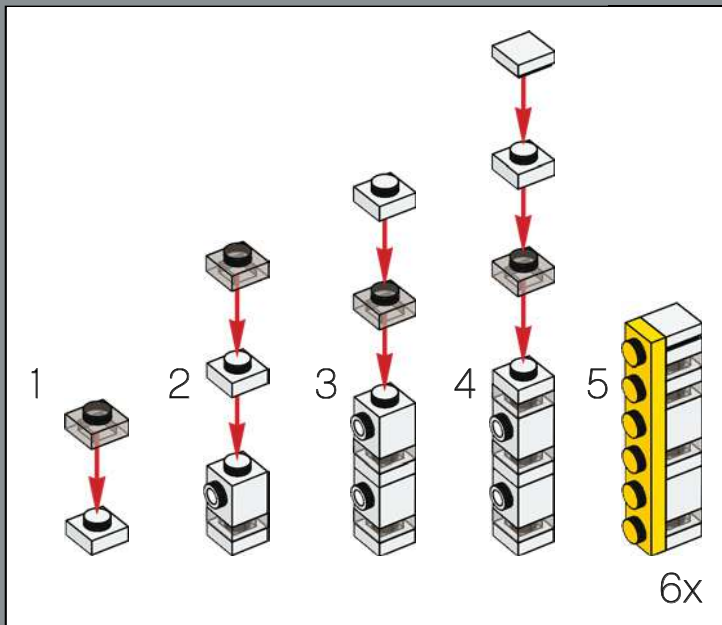
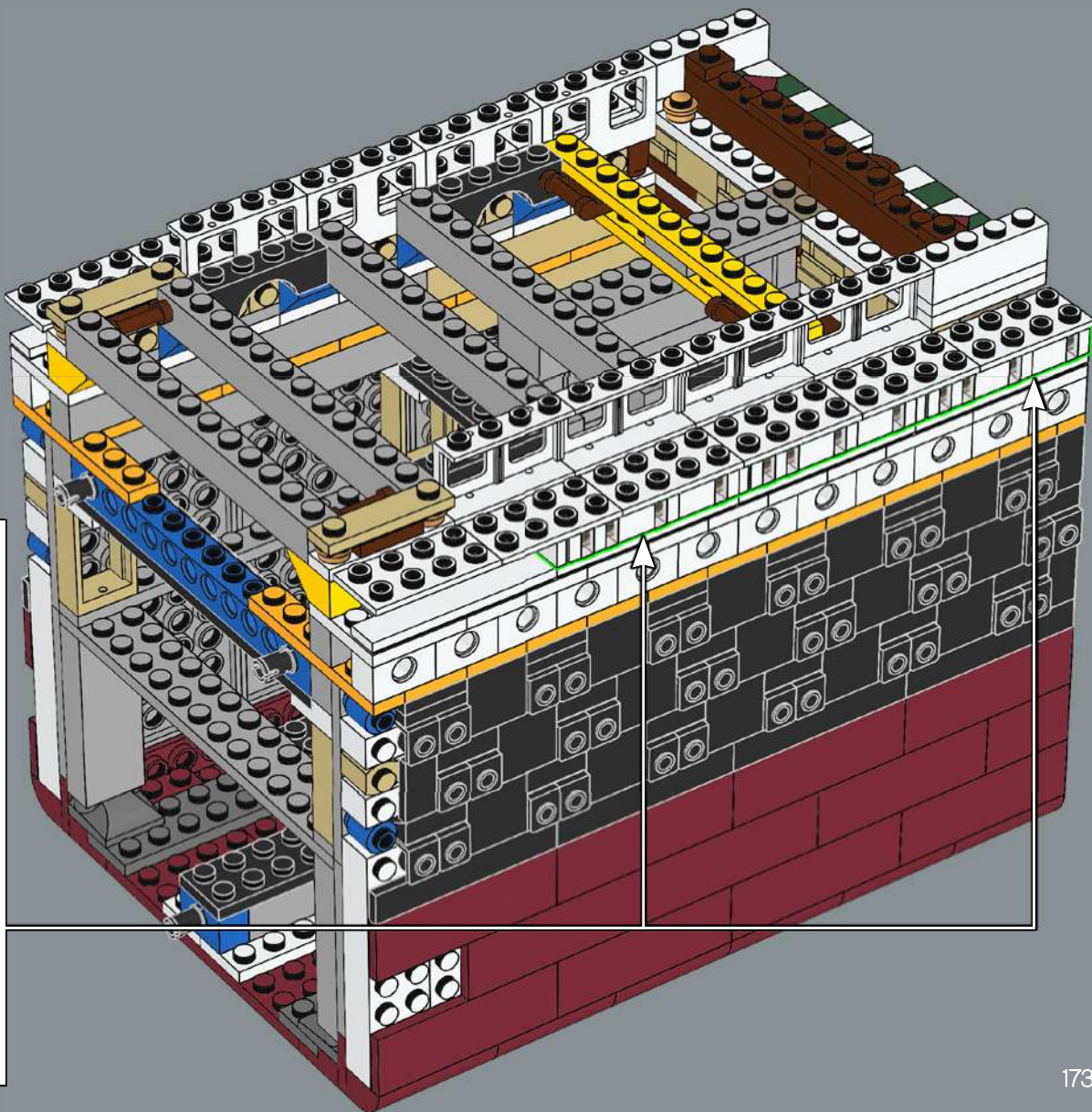

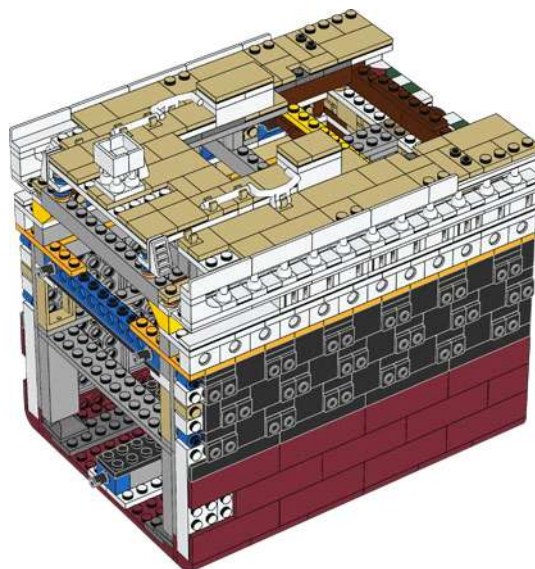
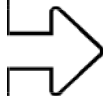

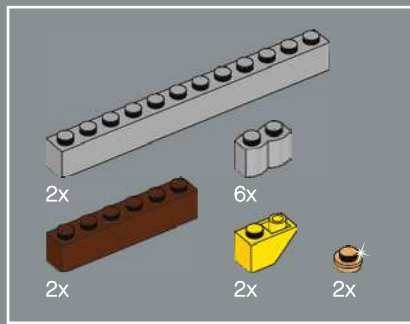

219

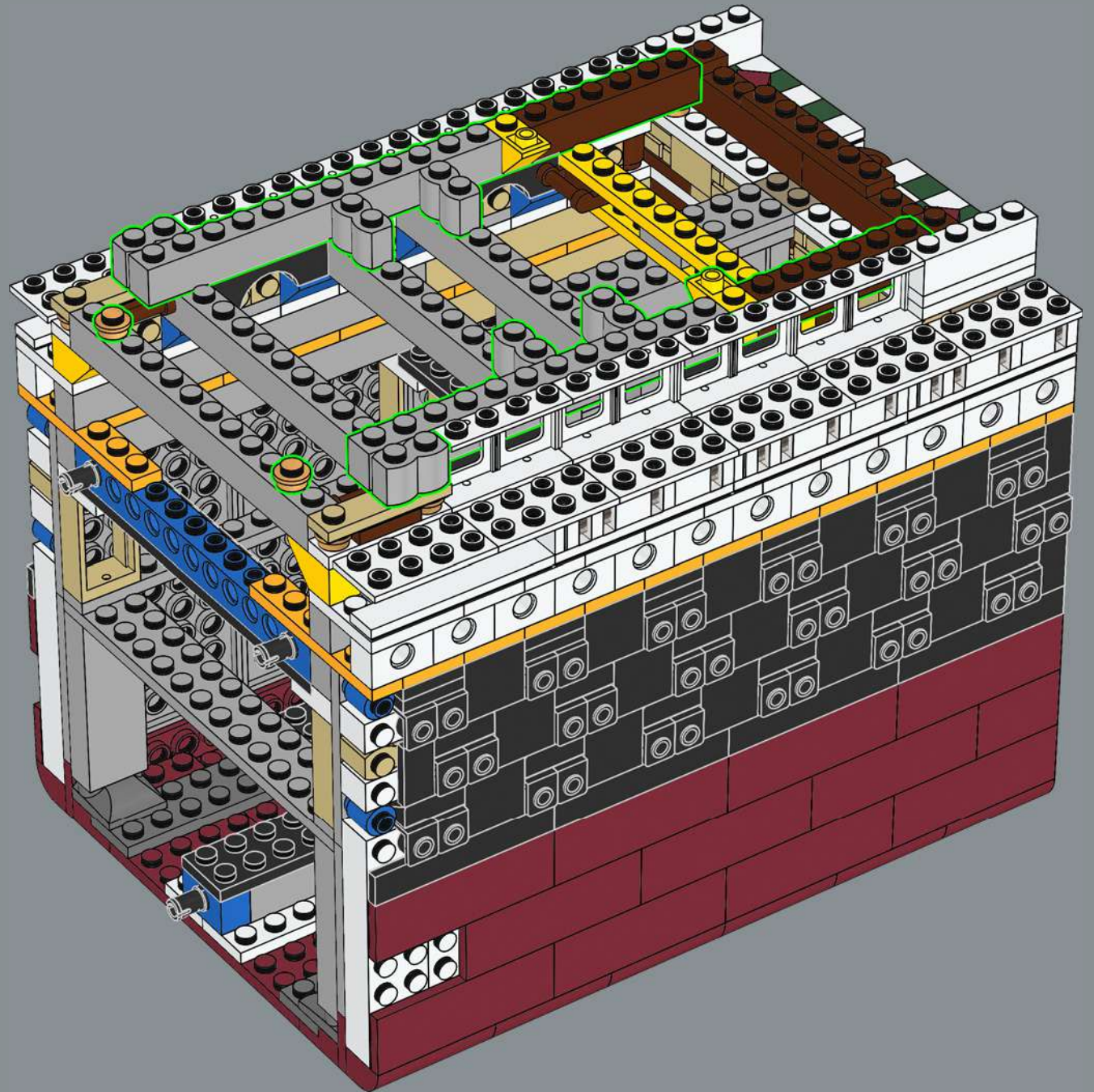

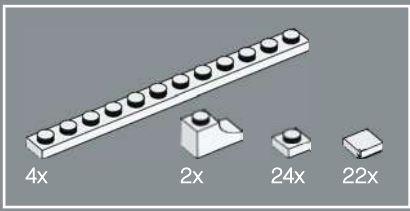

220

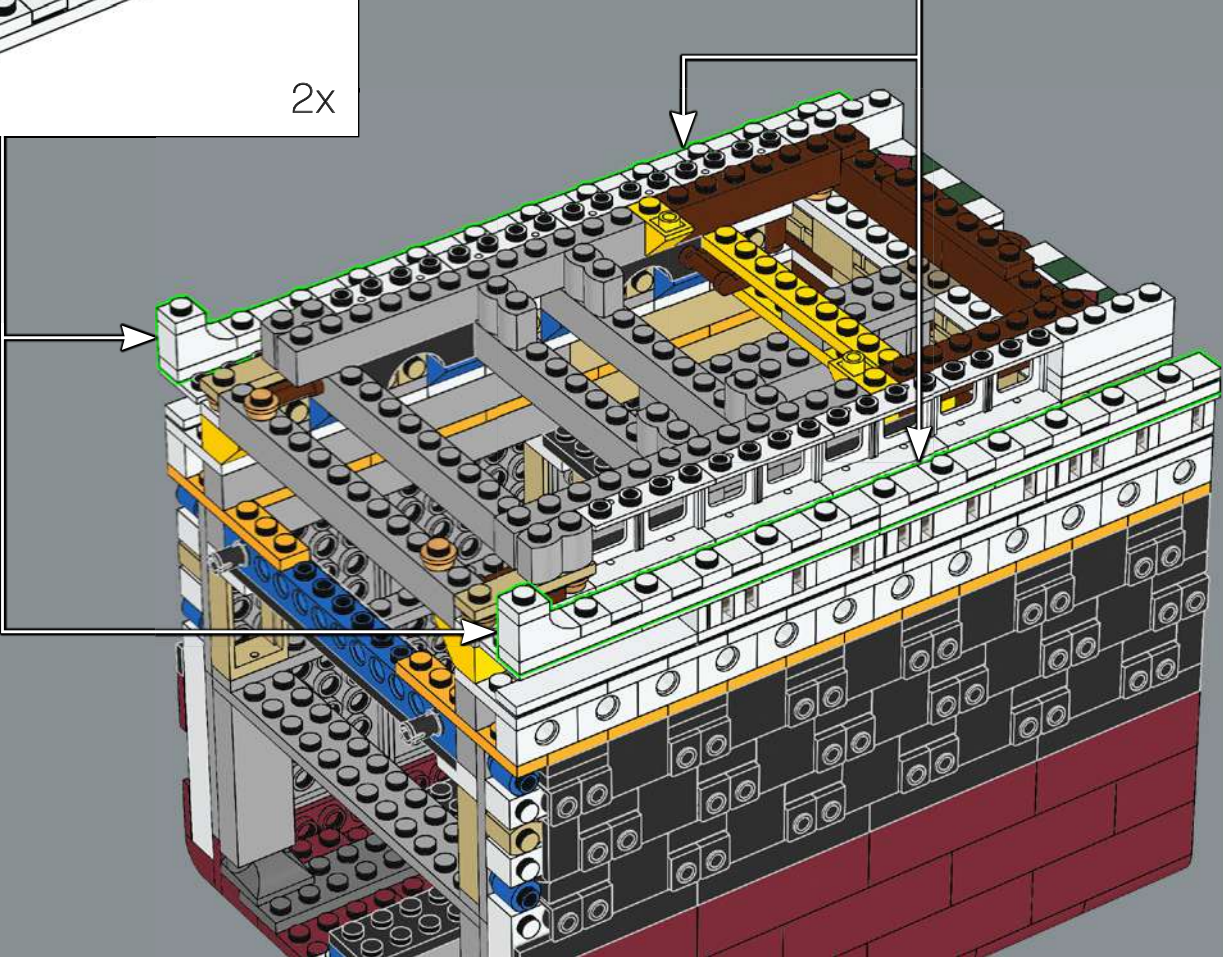
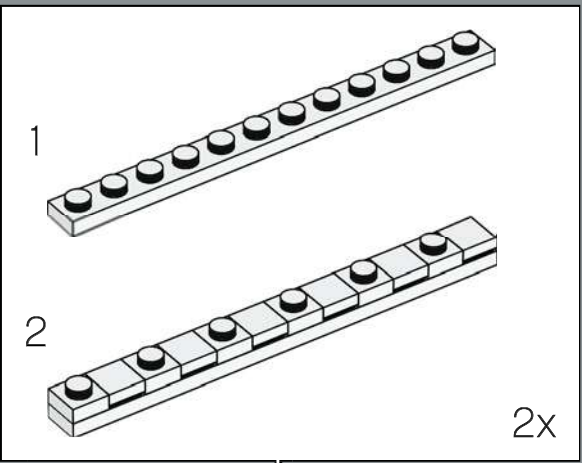
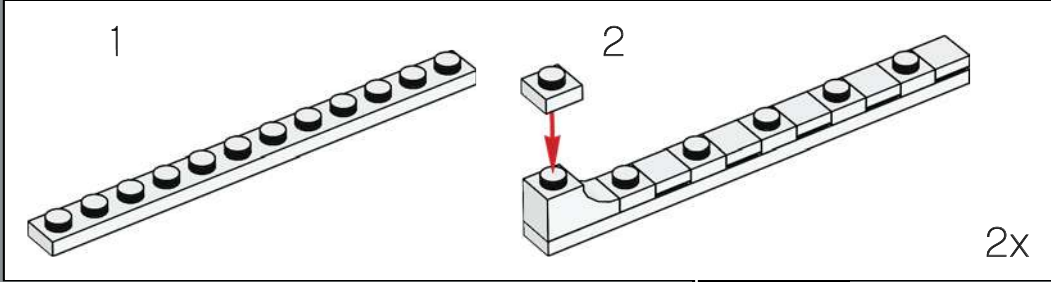

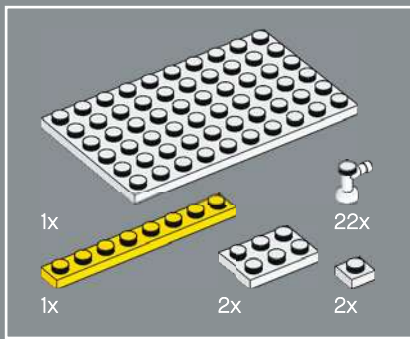

222

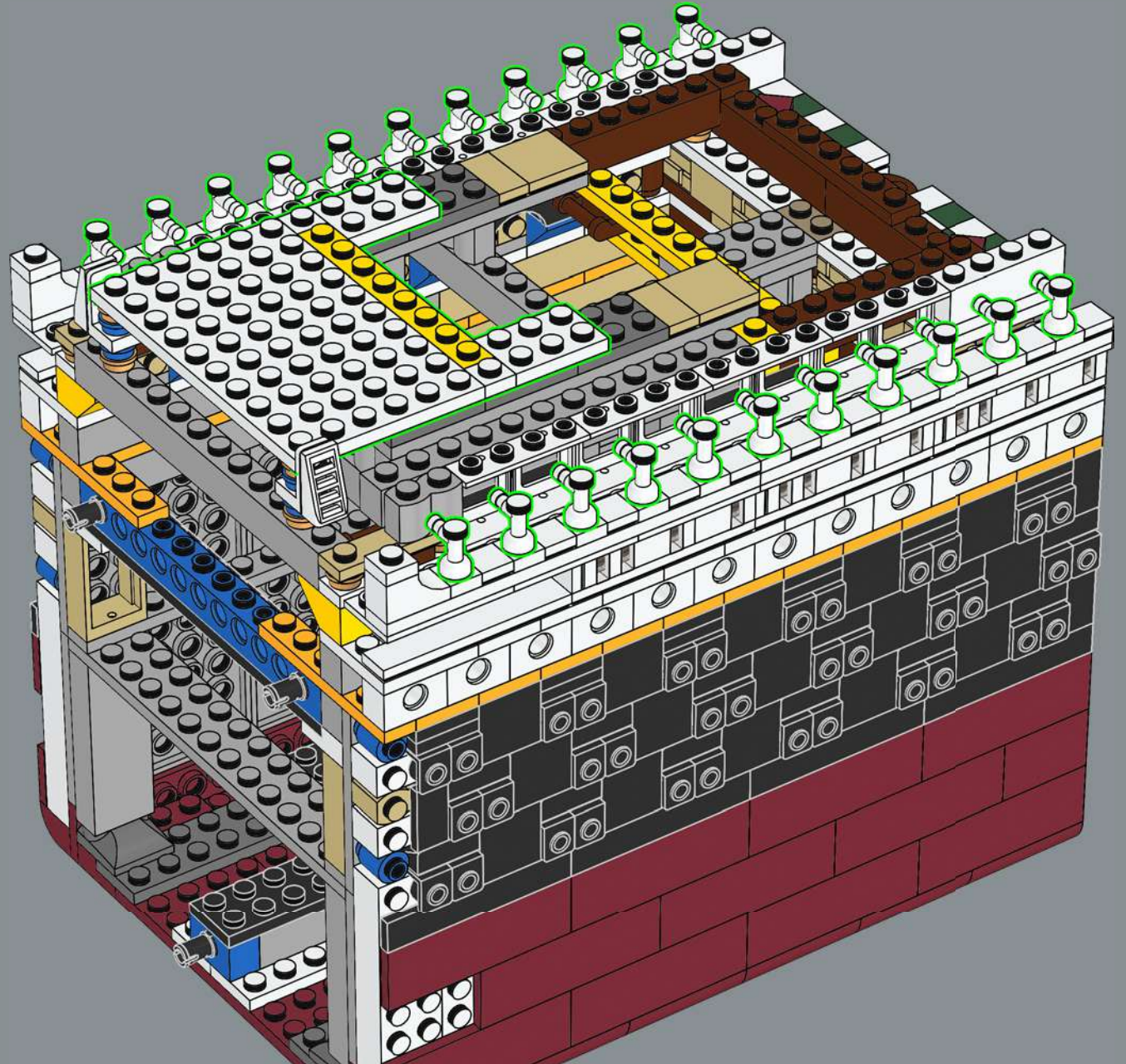

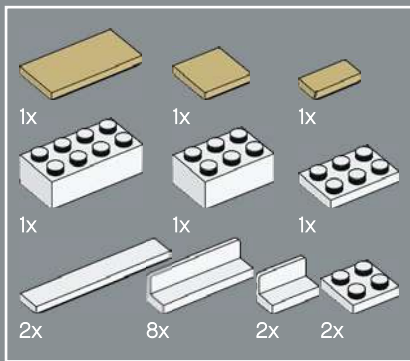

223

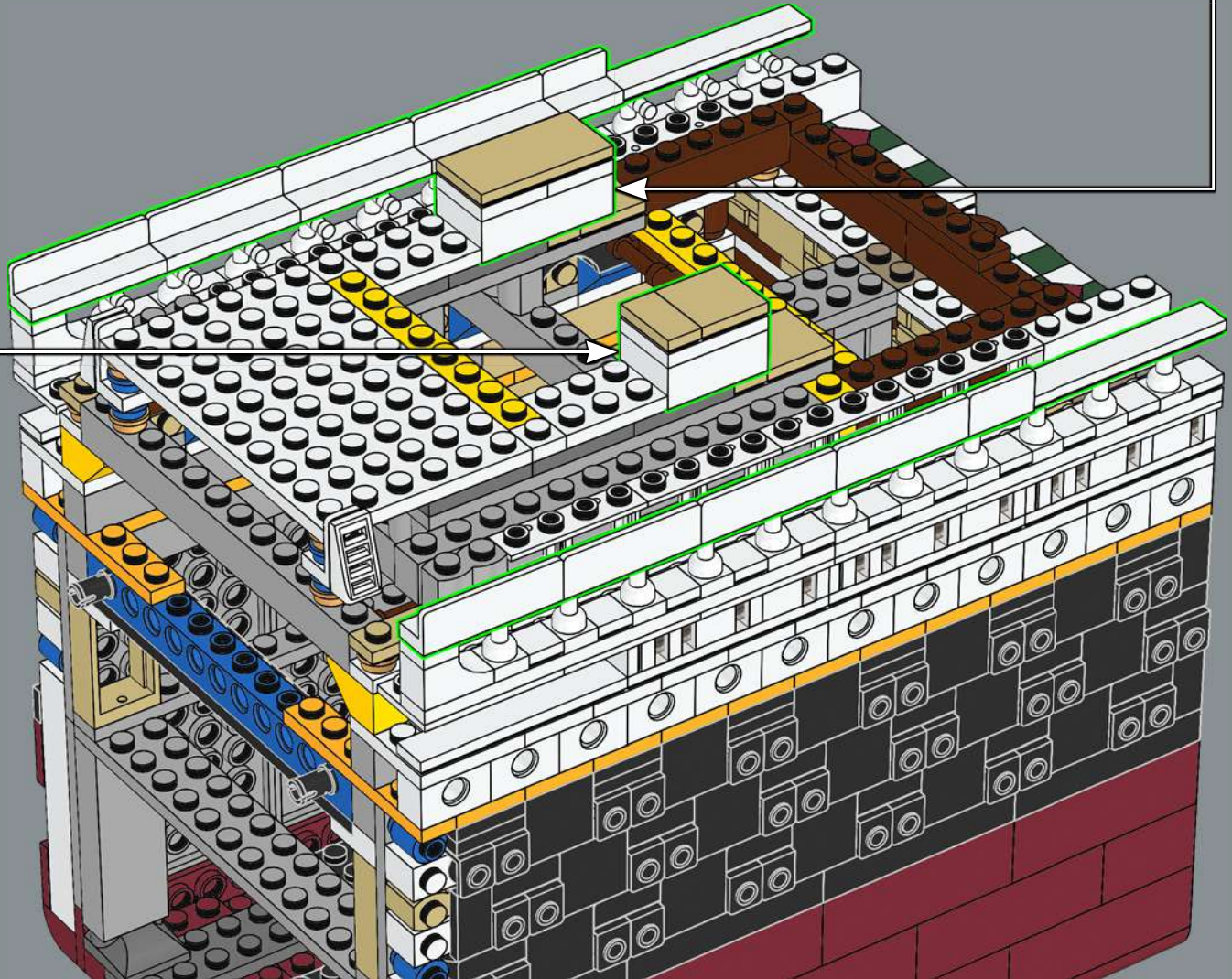
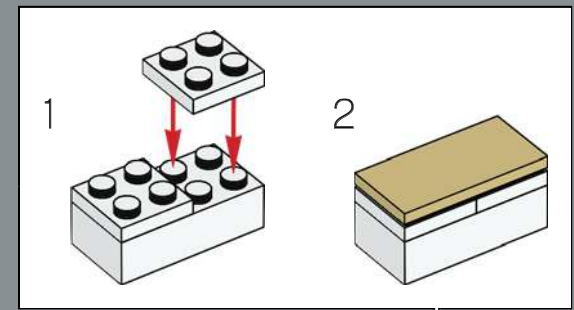
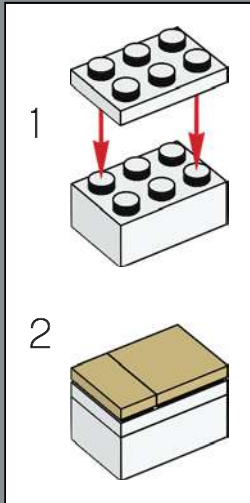

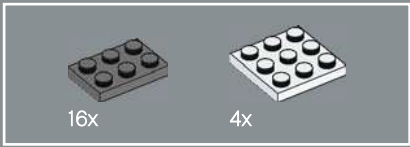

224

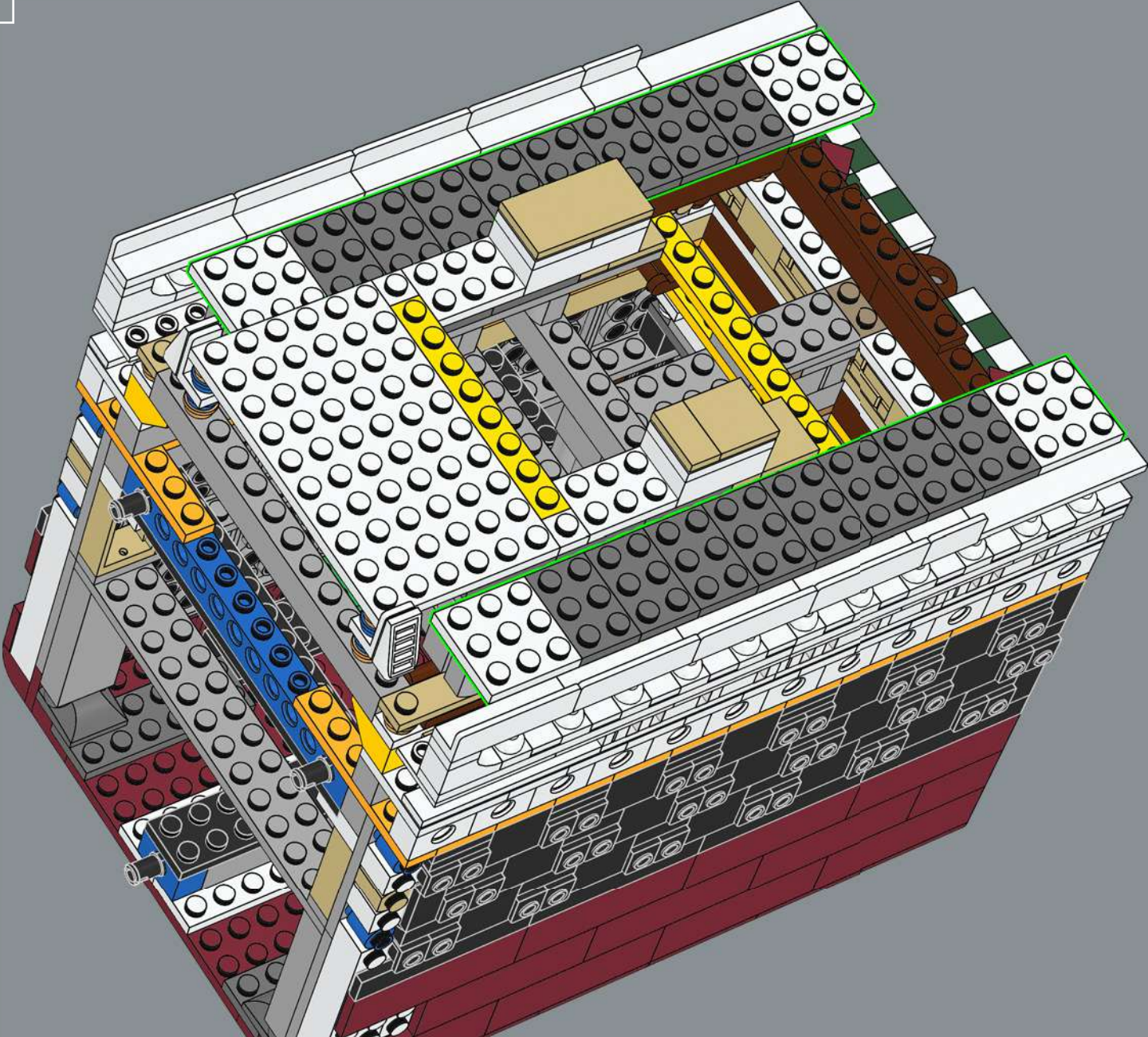

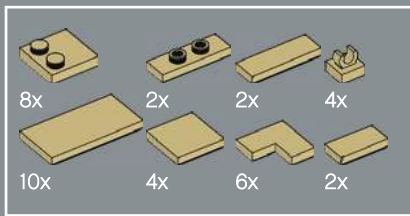

225

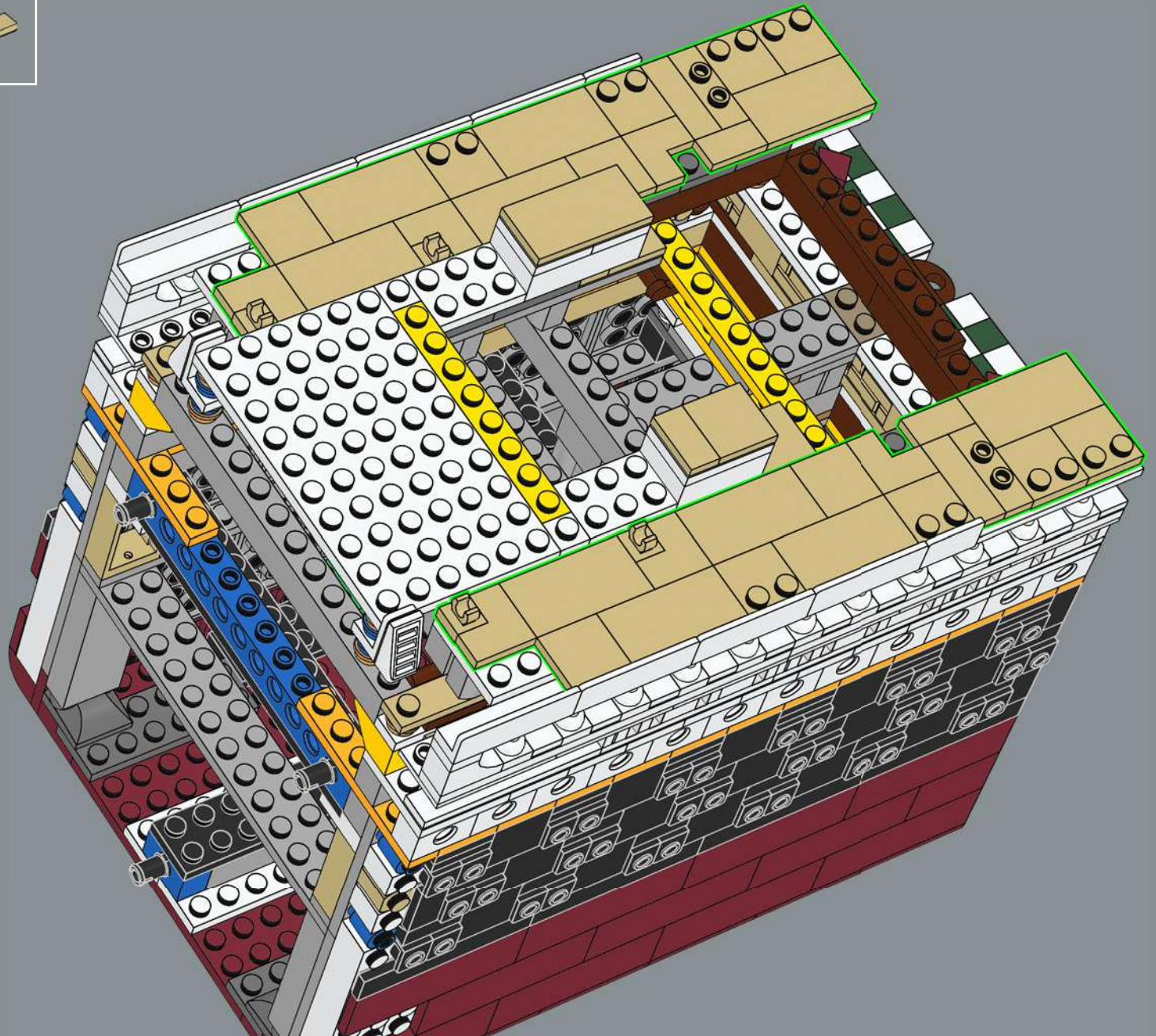

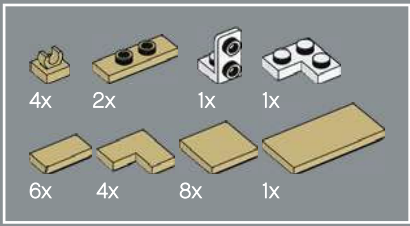

226

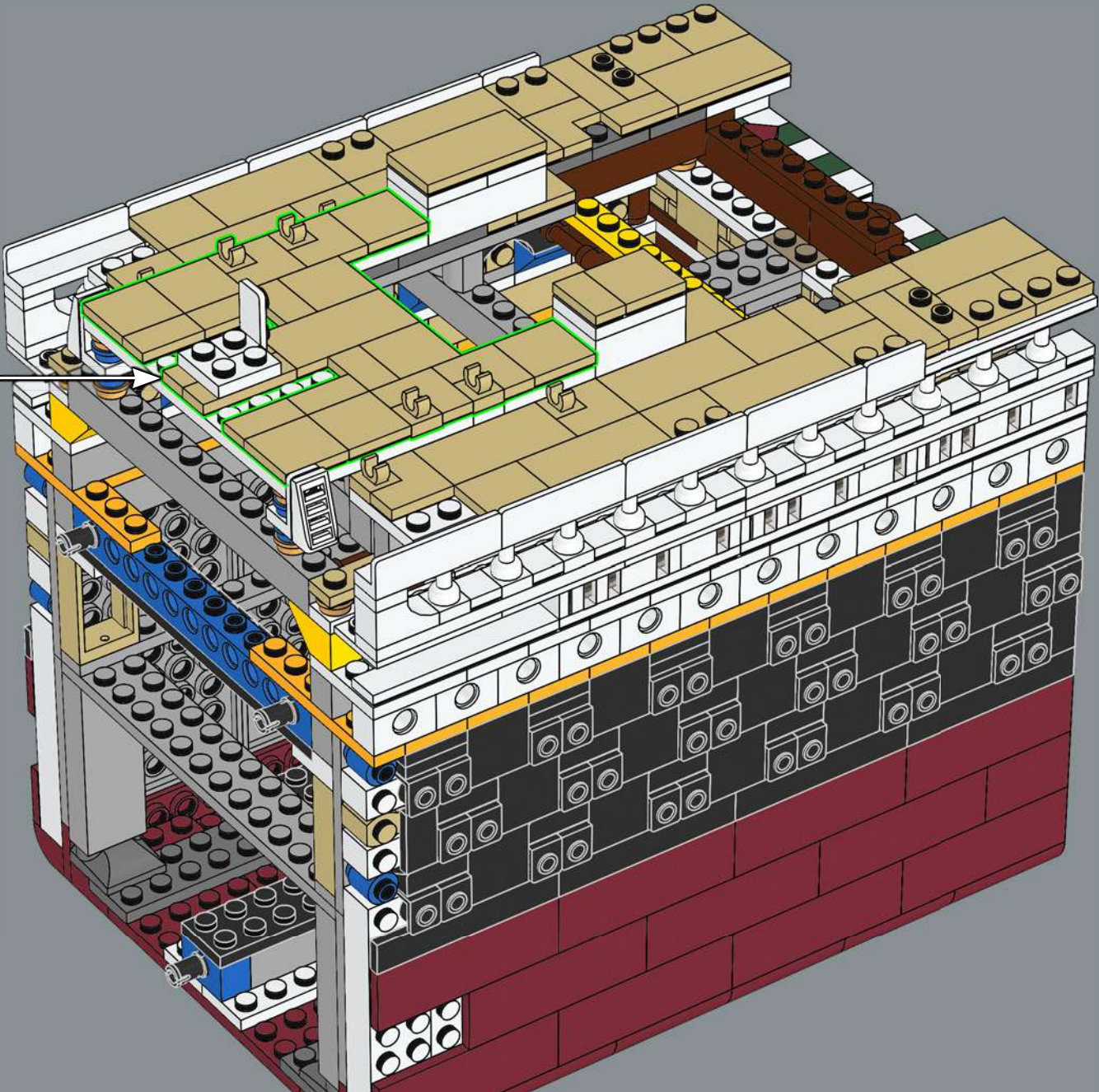
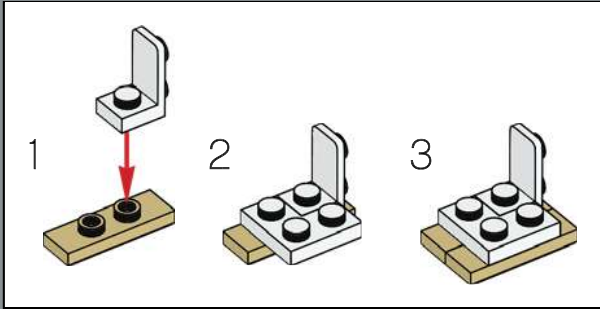



227

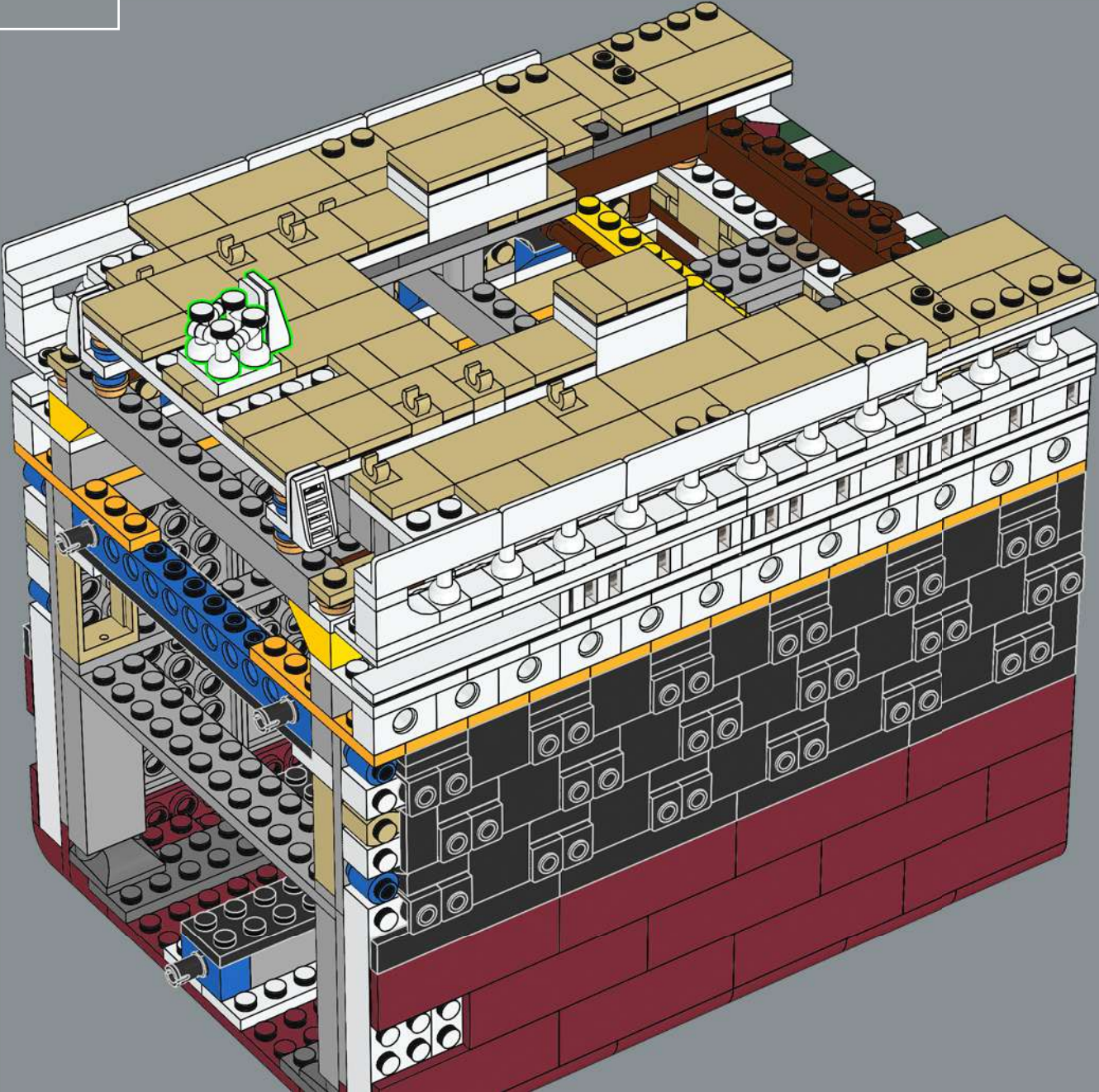

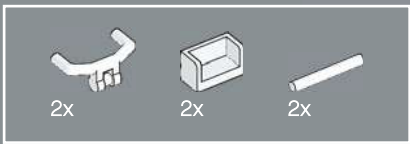

228

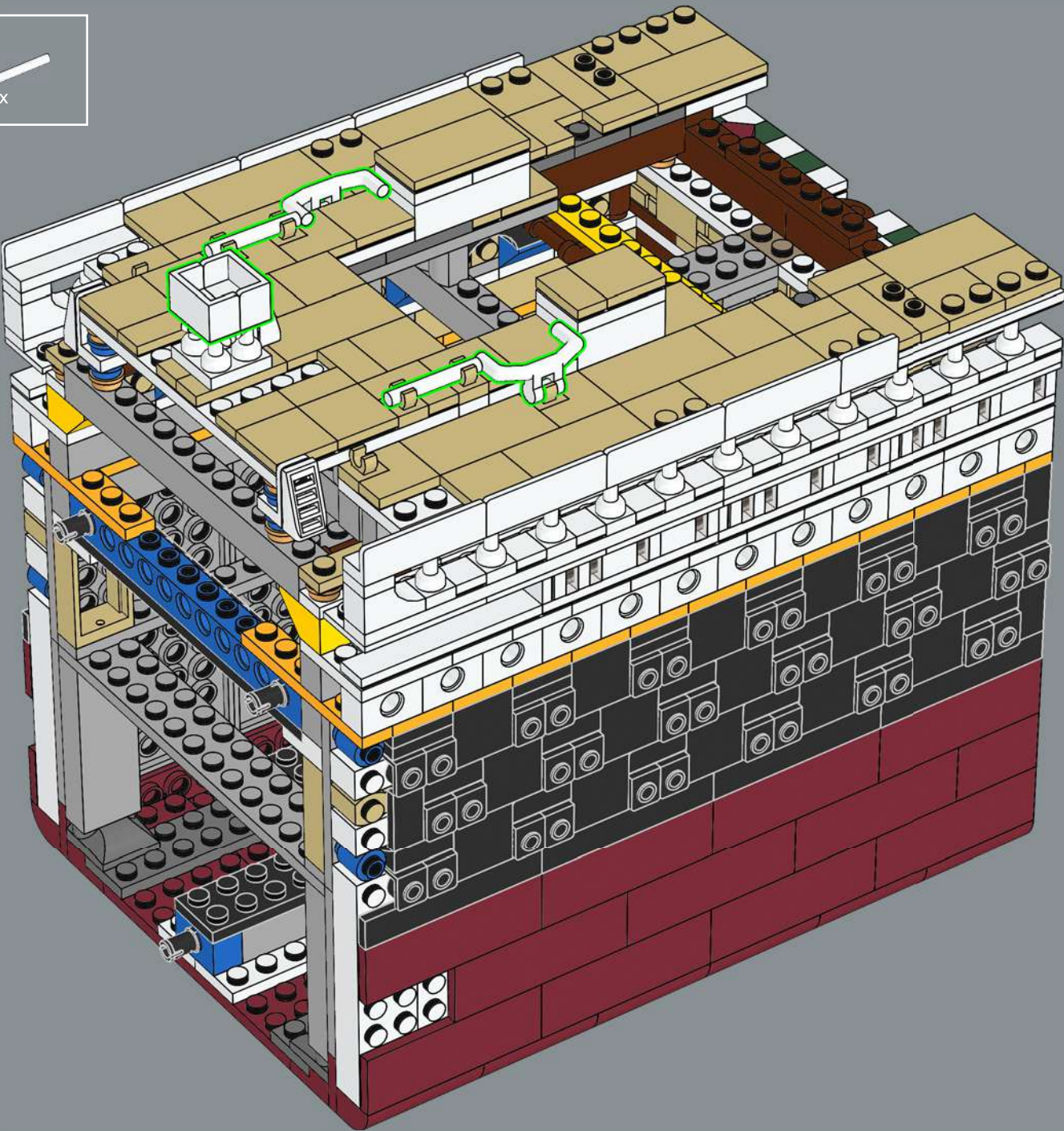

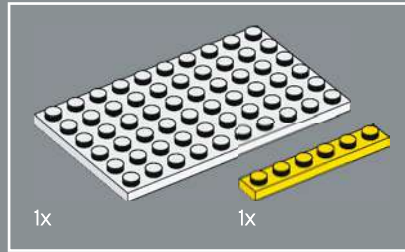
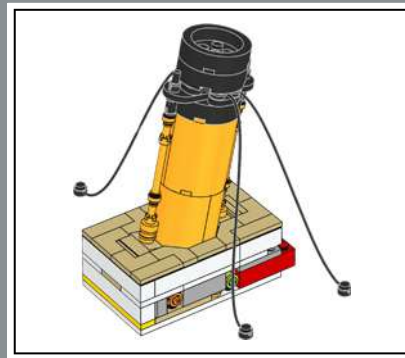
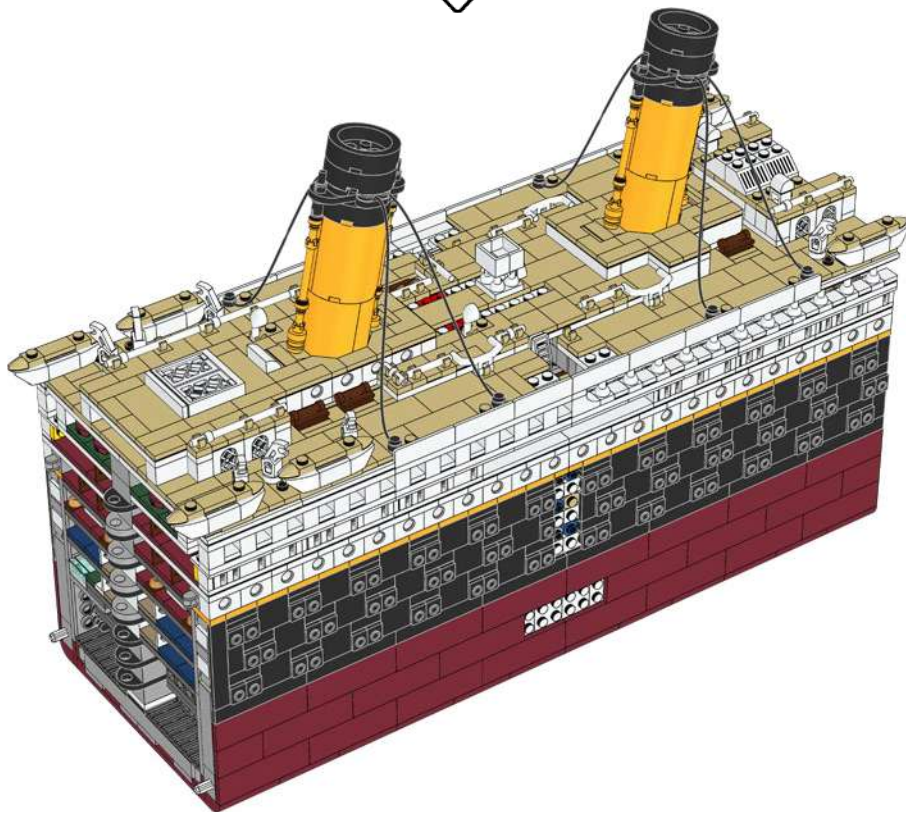
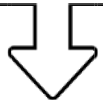

229

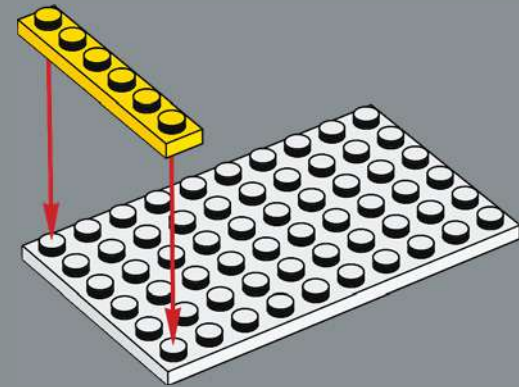



230

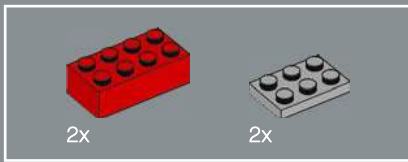
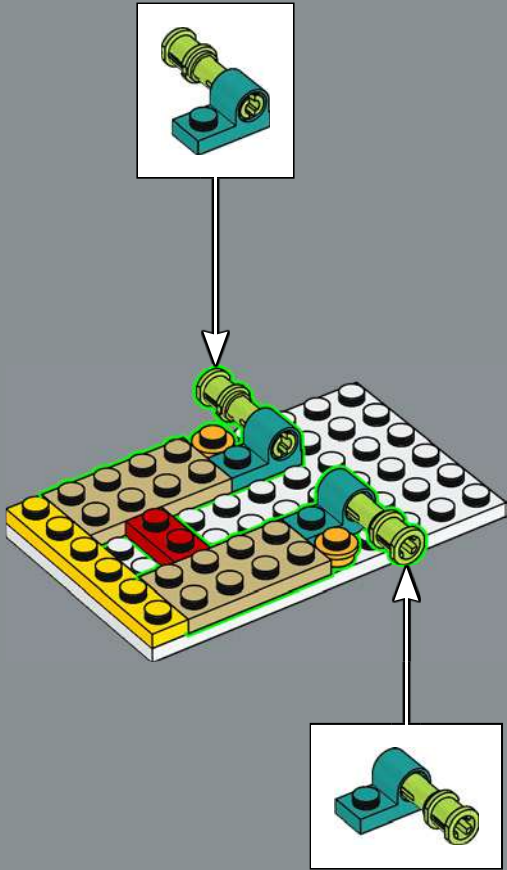

231

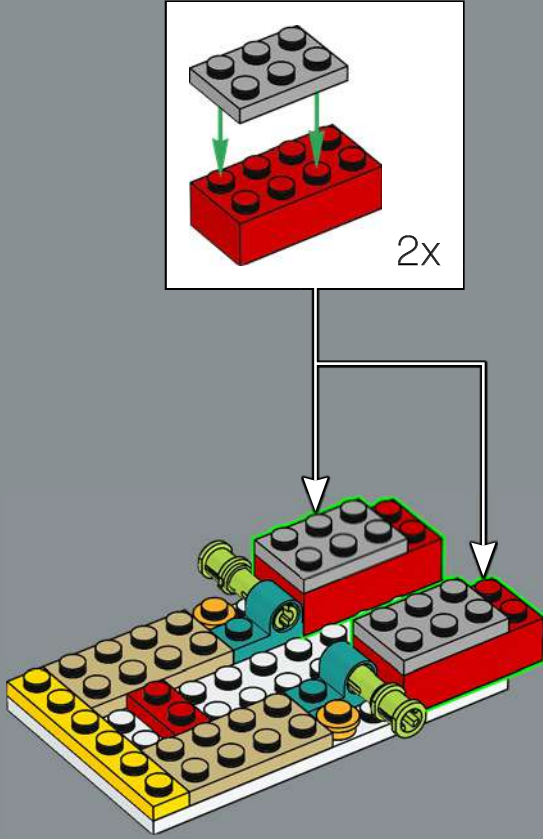

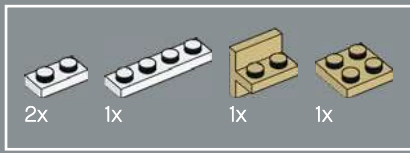

232

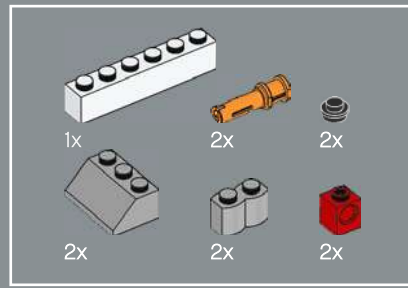
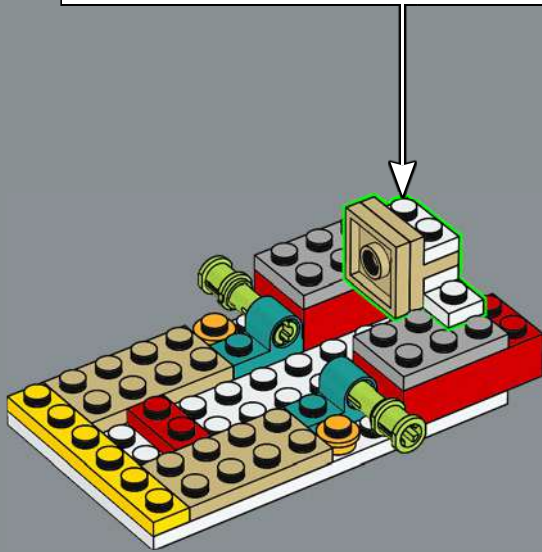
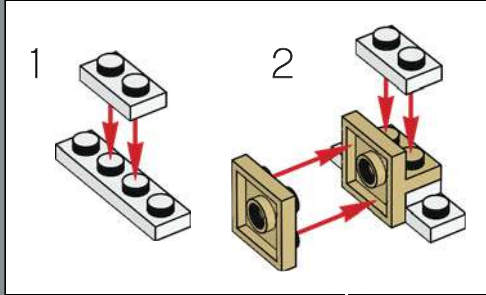

233

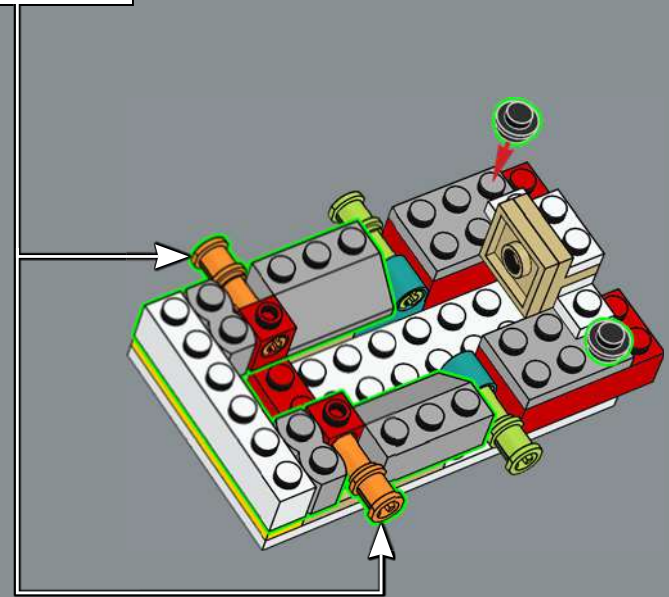
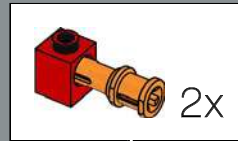

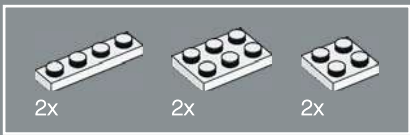

234

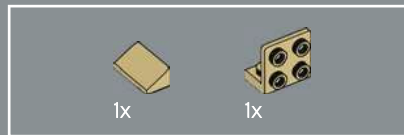
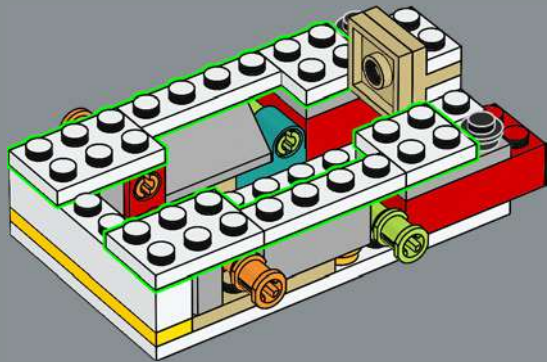

235

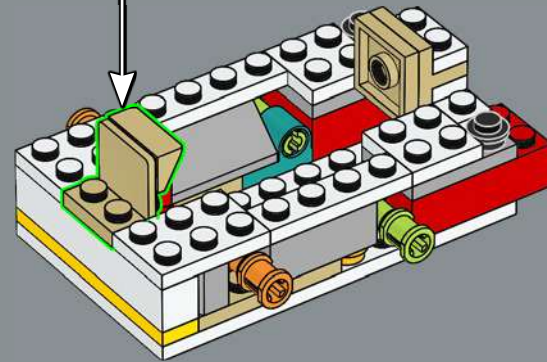
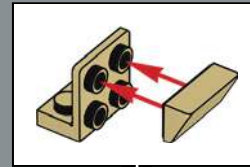

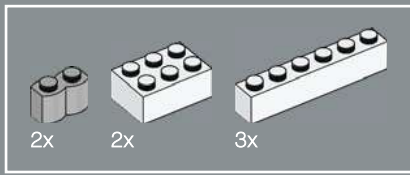

236

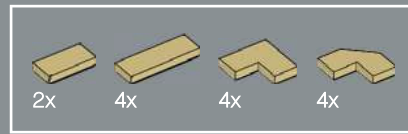
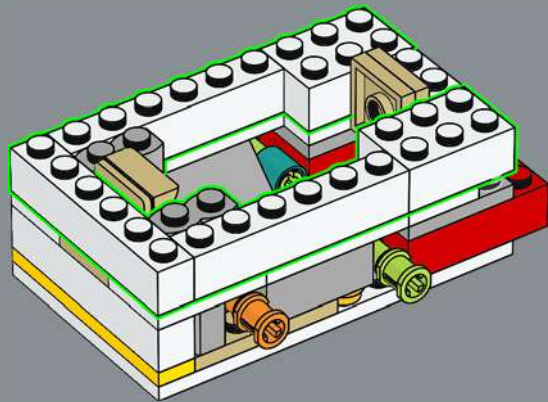

237

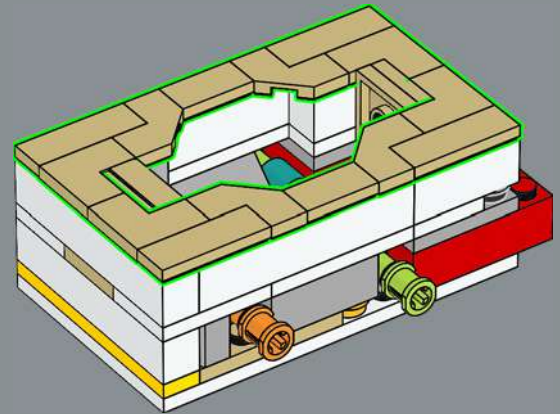

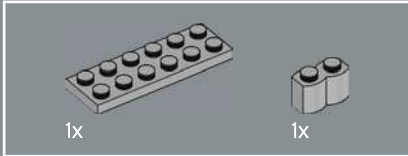
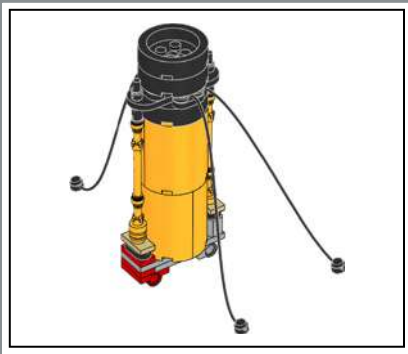

238

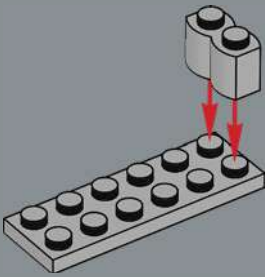

239

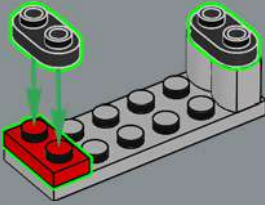

240

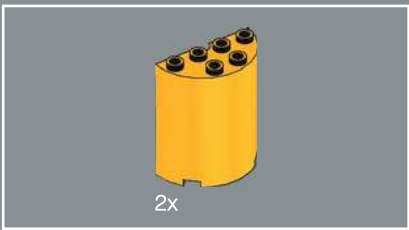
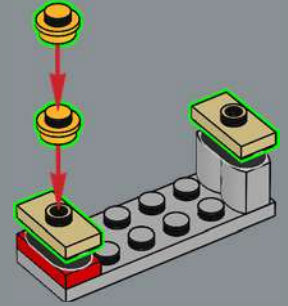

241

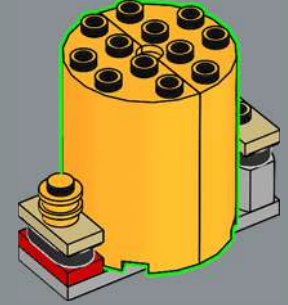

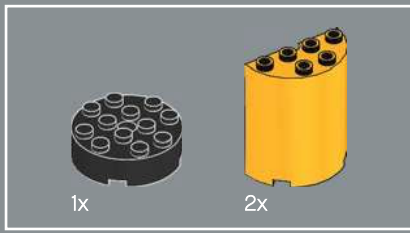

242

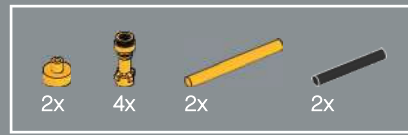
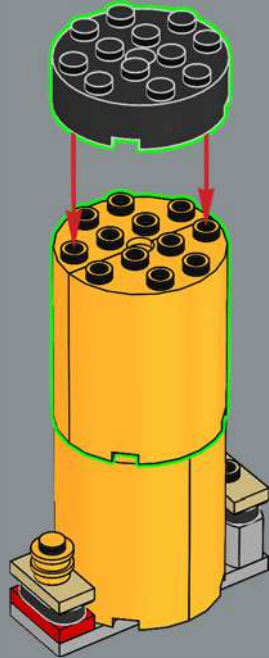

243

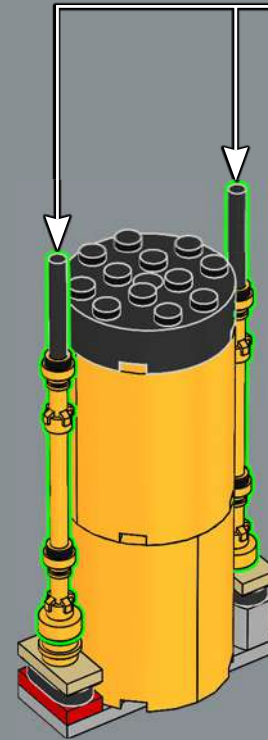
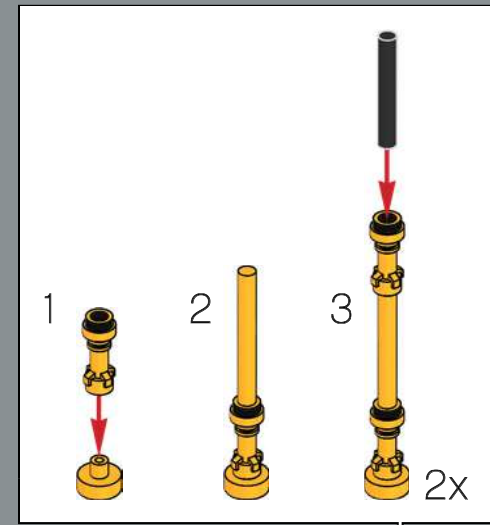



244

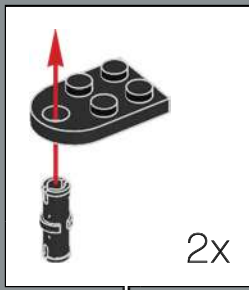

2x

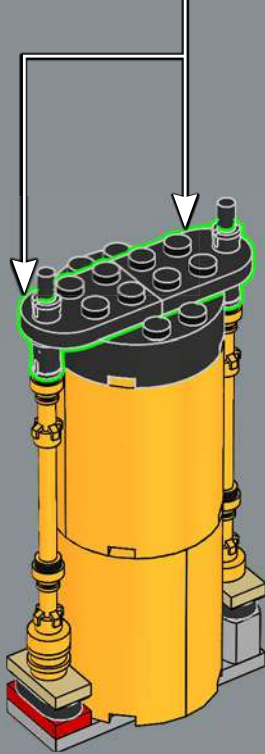

245

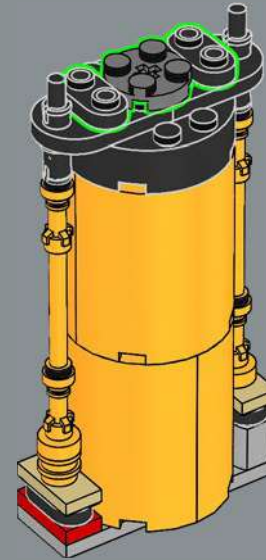

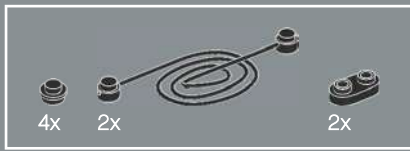

246

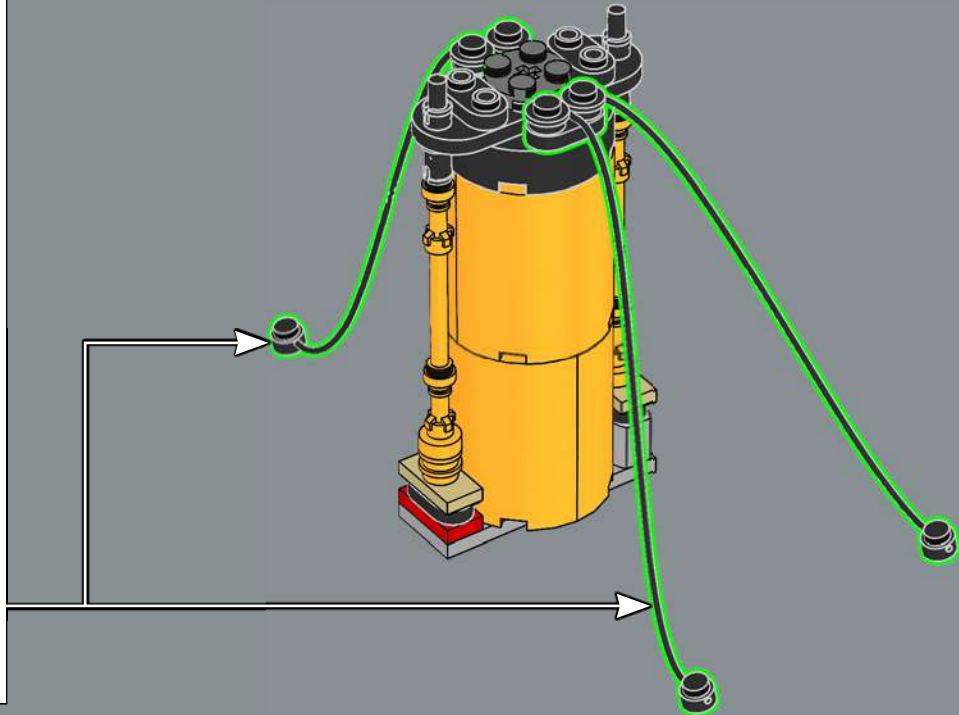
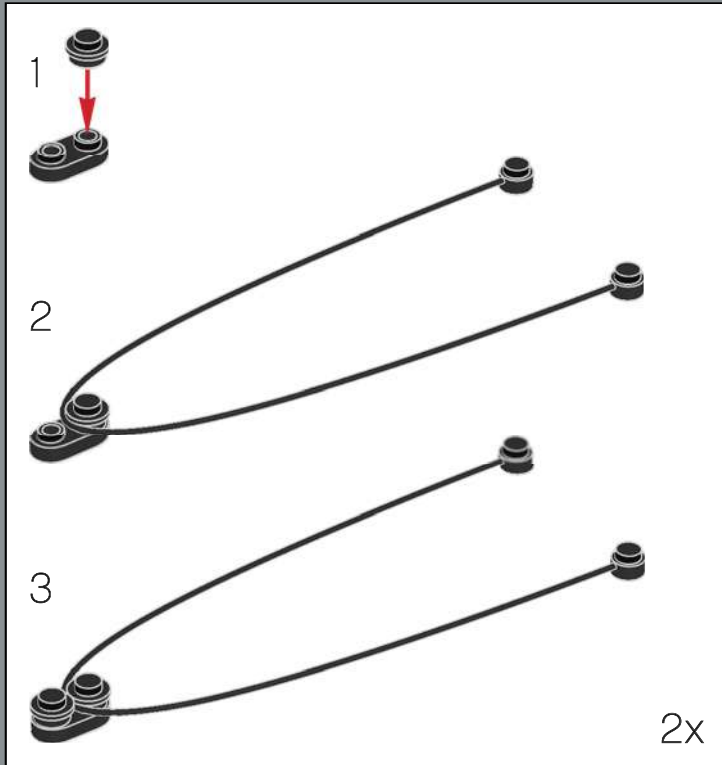

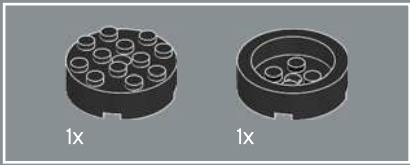

247

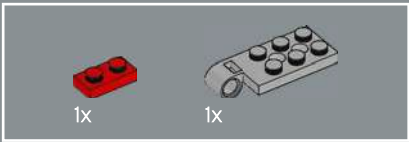
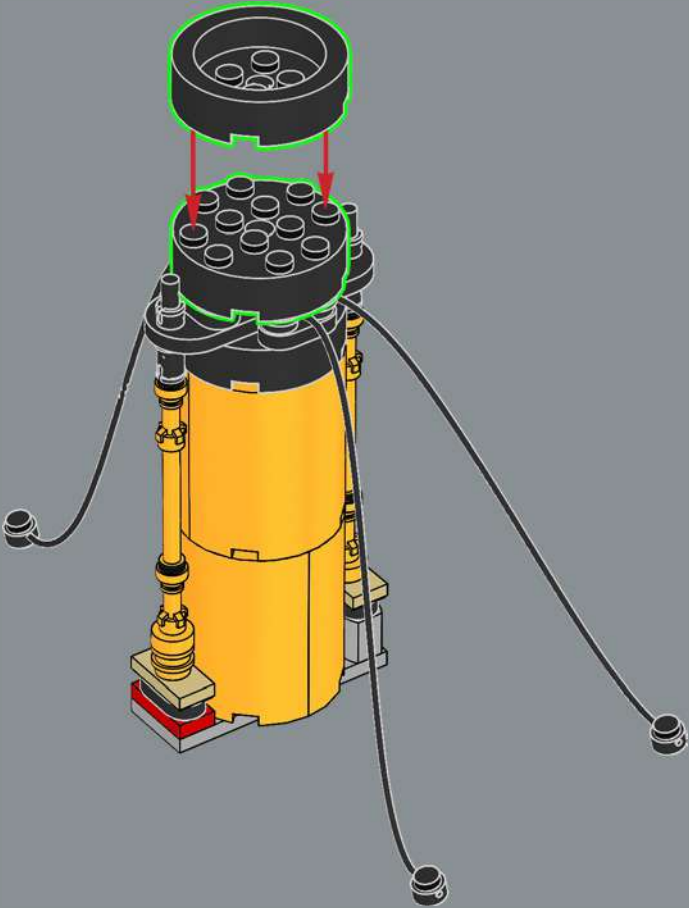

248

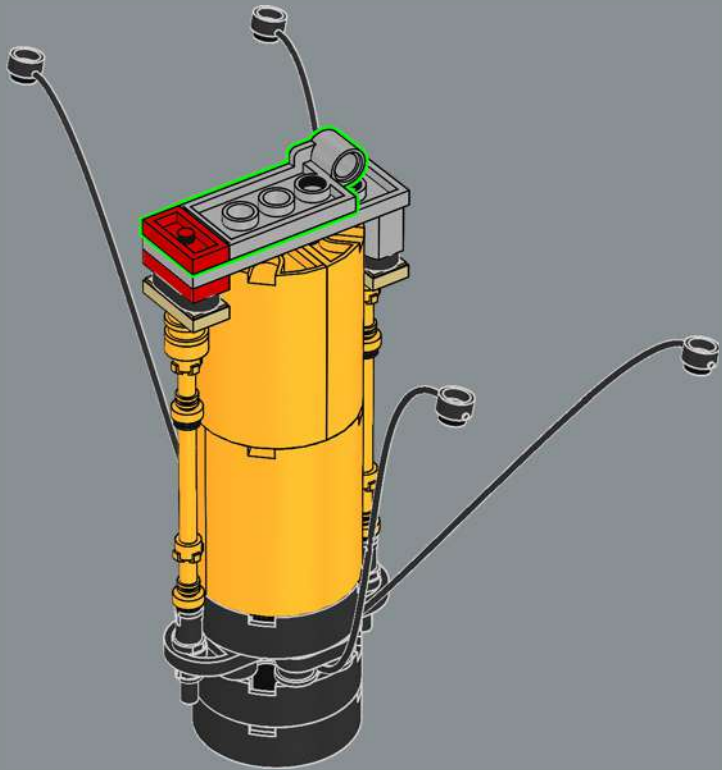

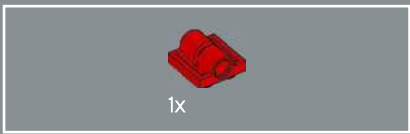

249

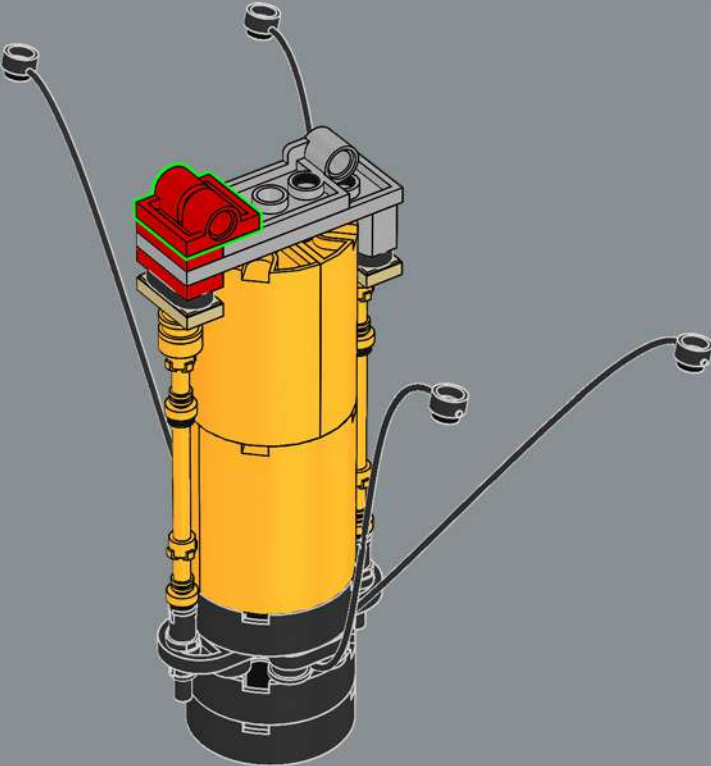

250

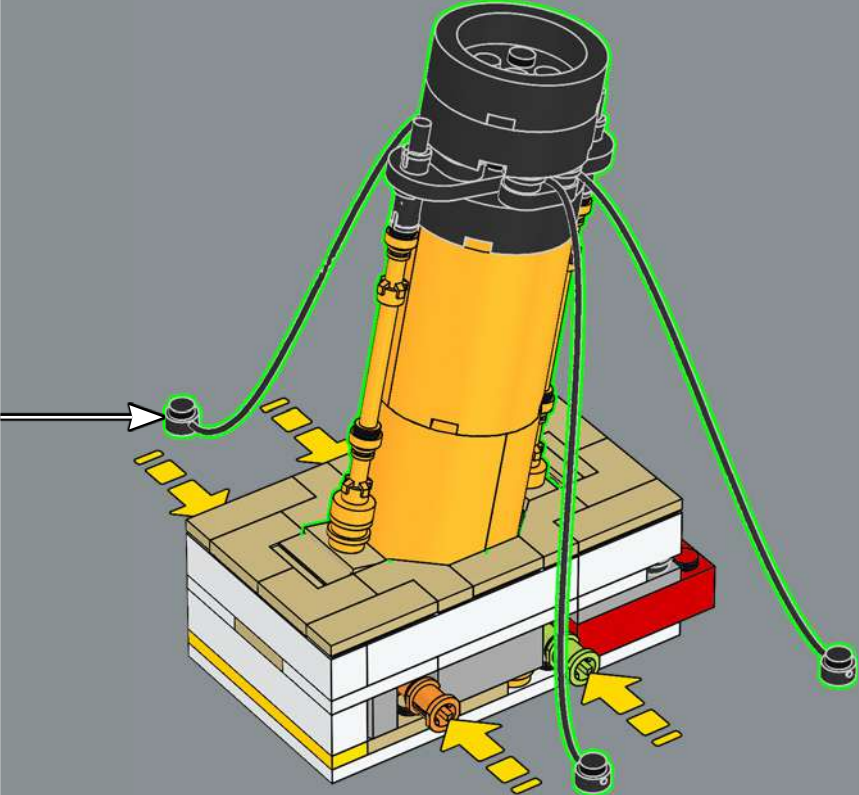

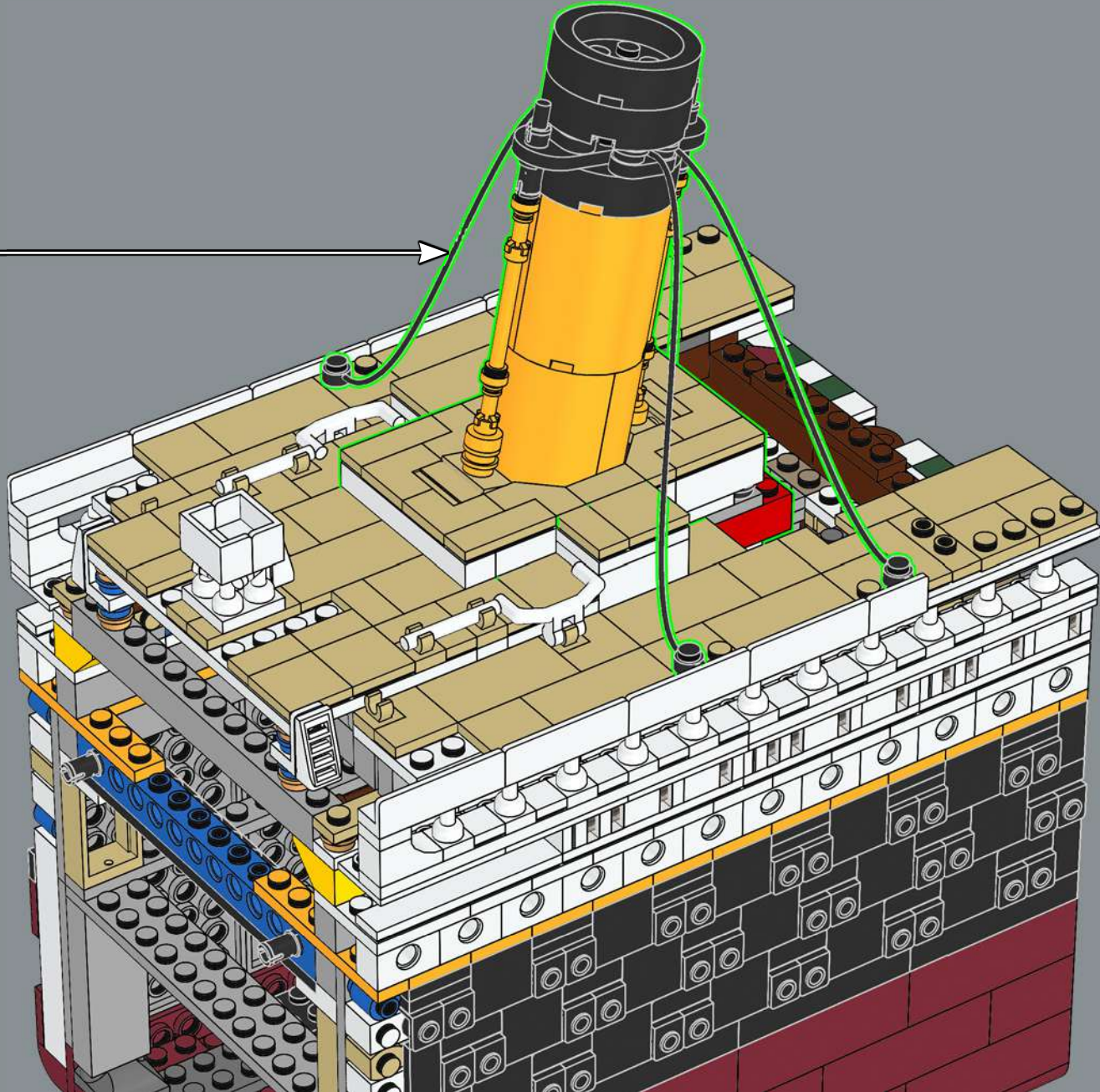

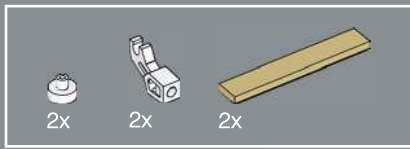

252

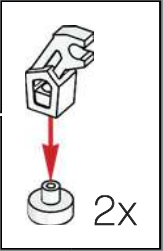
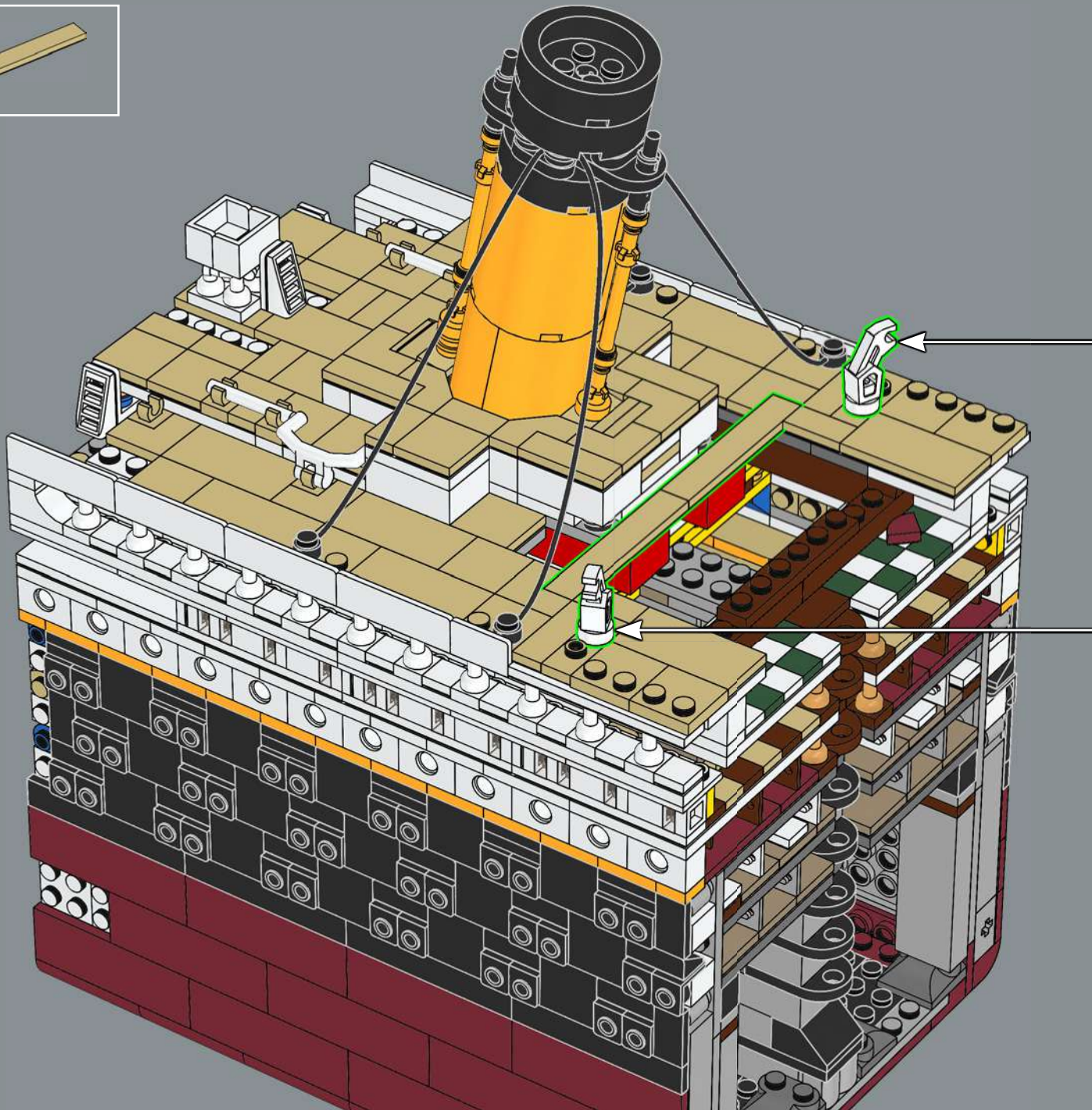

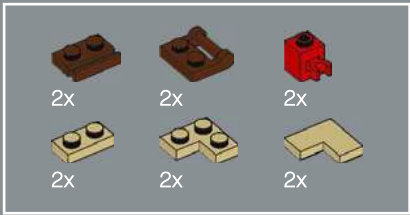

253

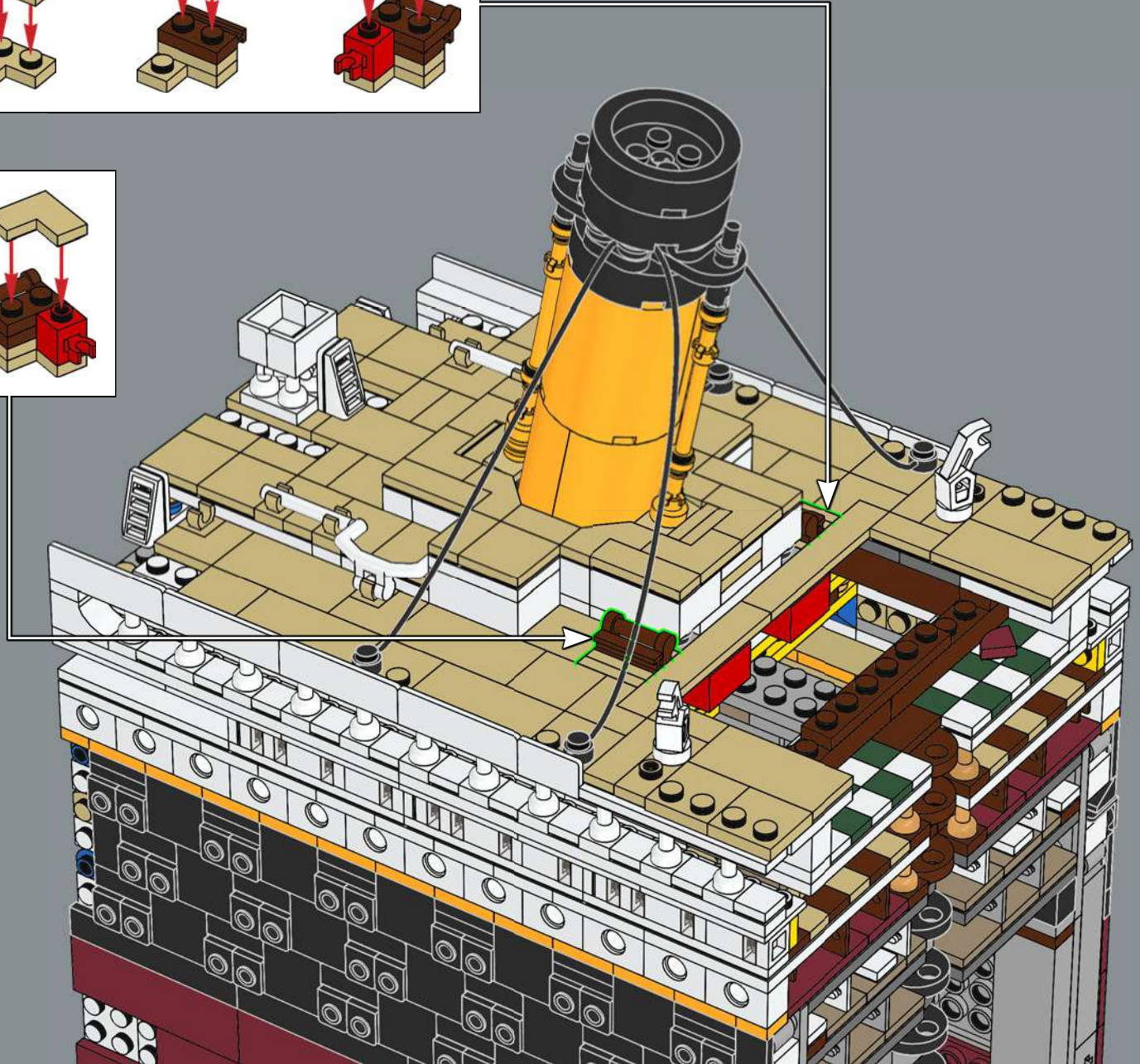
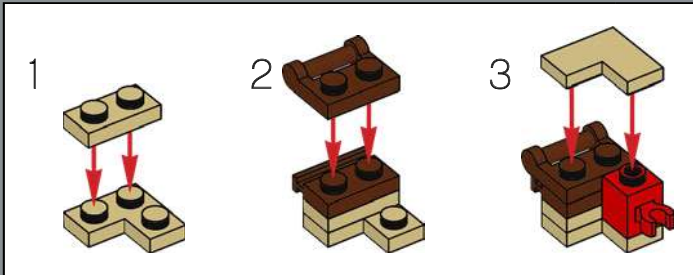
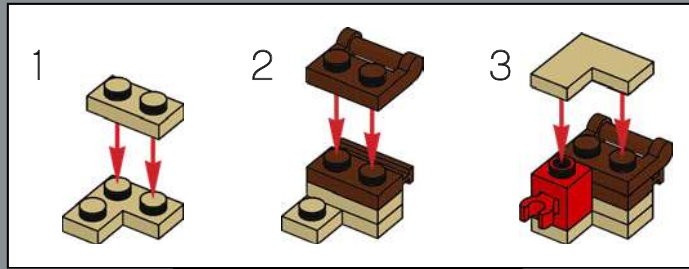

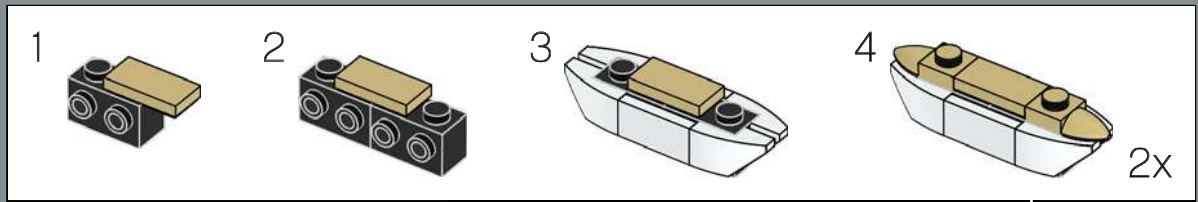
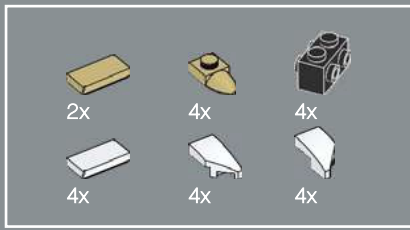

254

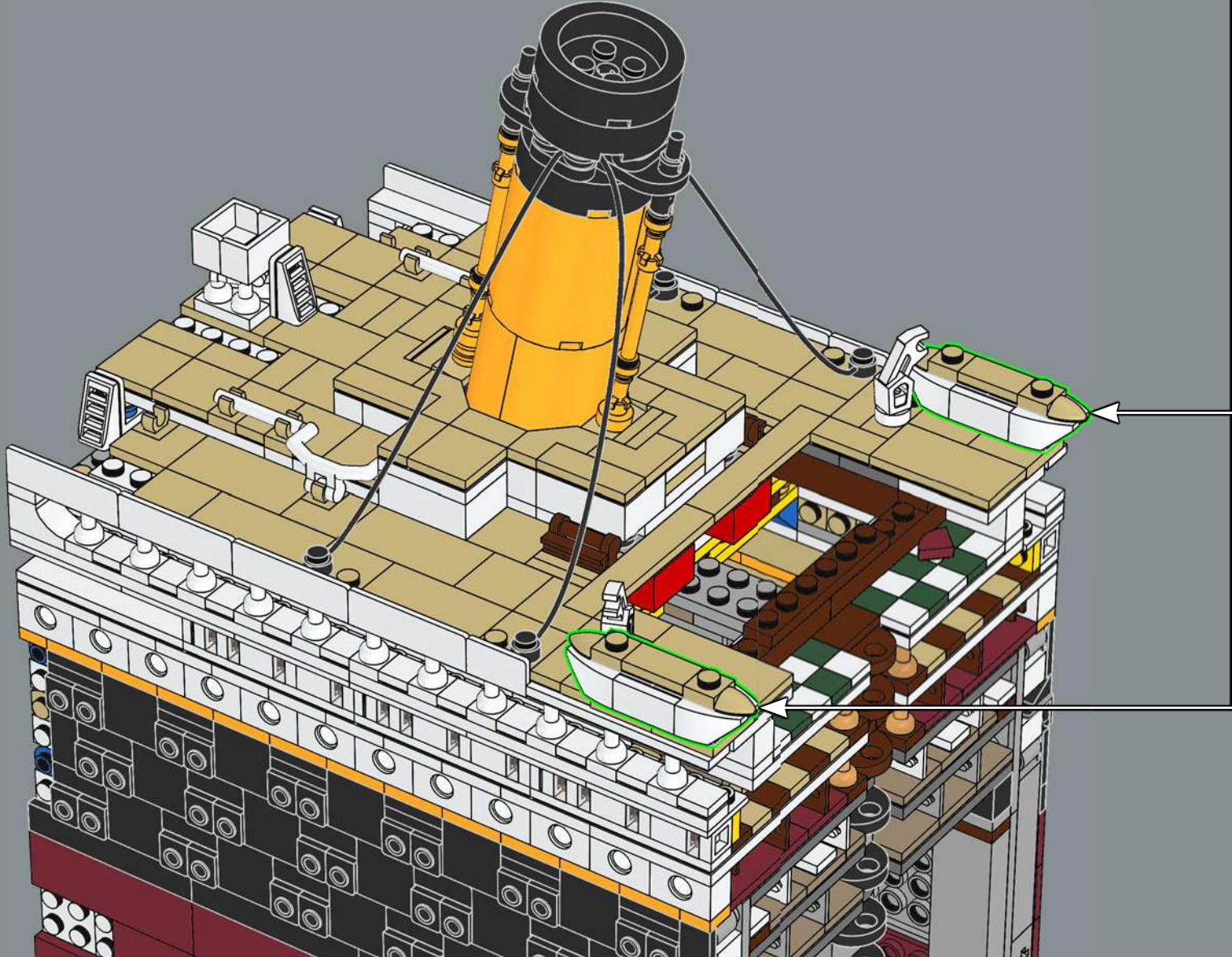

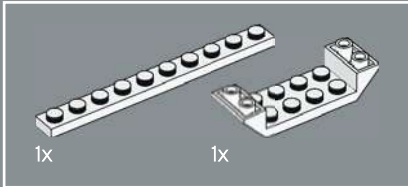
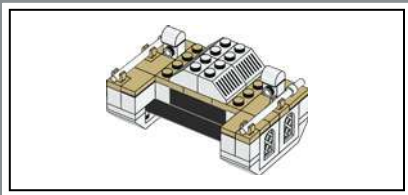

255

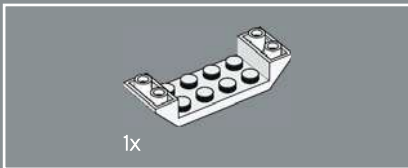
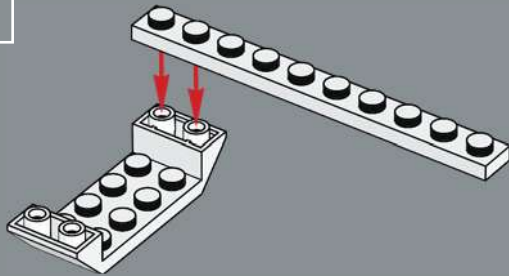

256

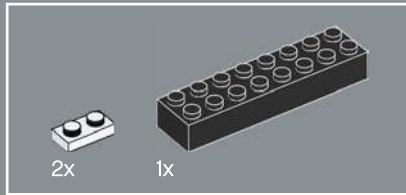
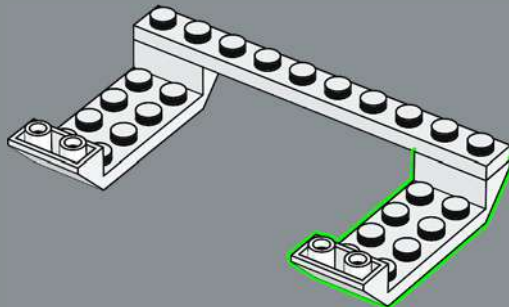

257

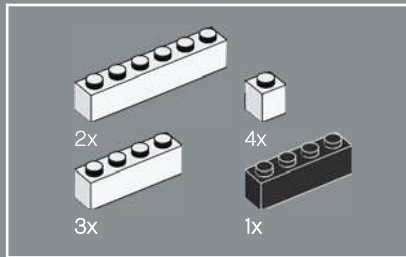
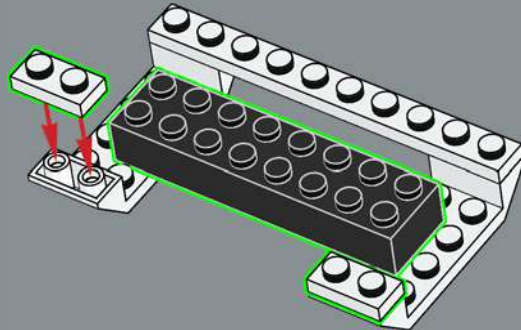

258

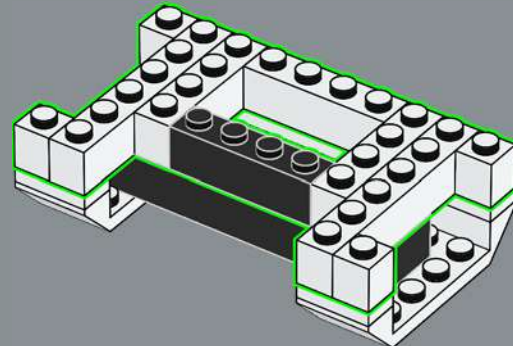

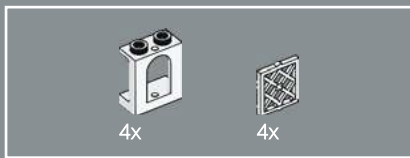

259

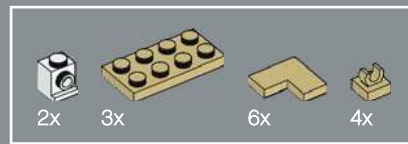
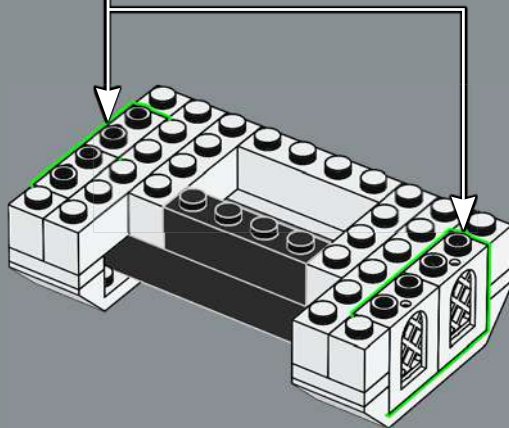
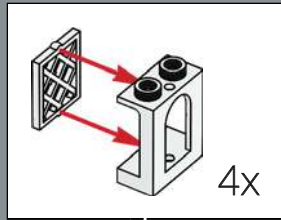

260

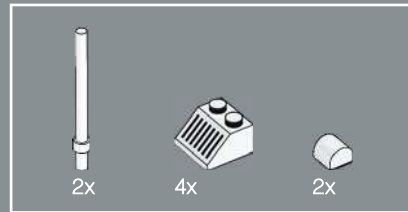
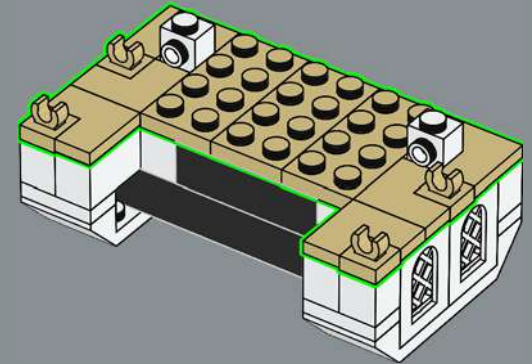

261

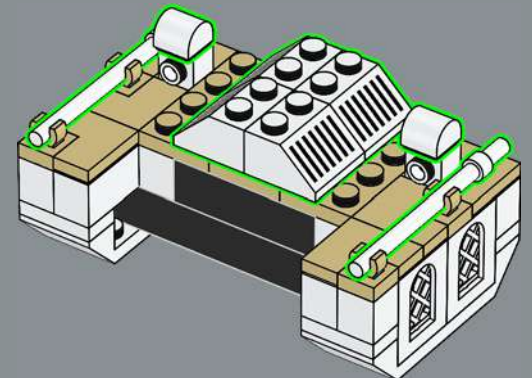

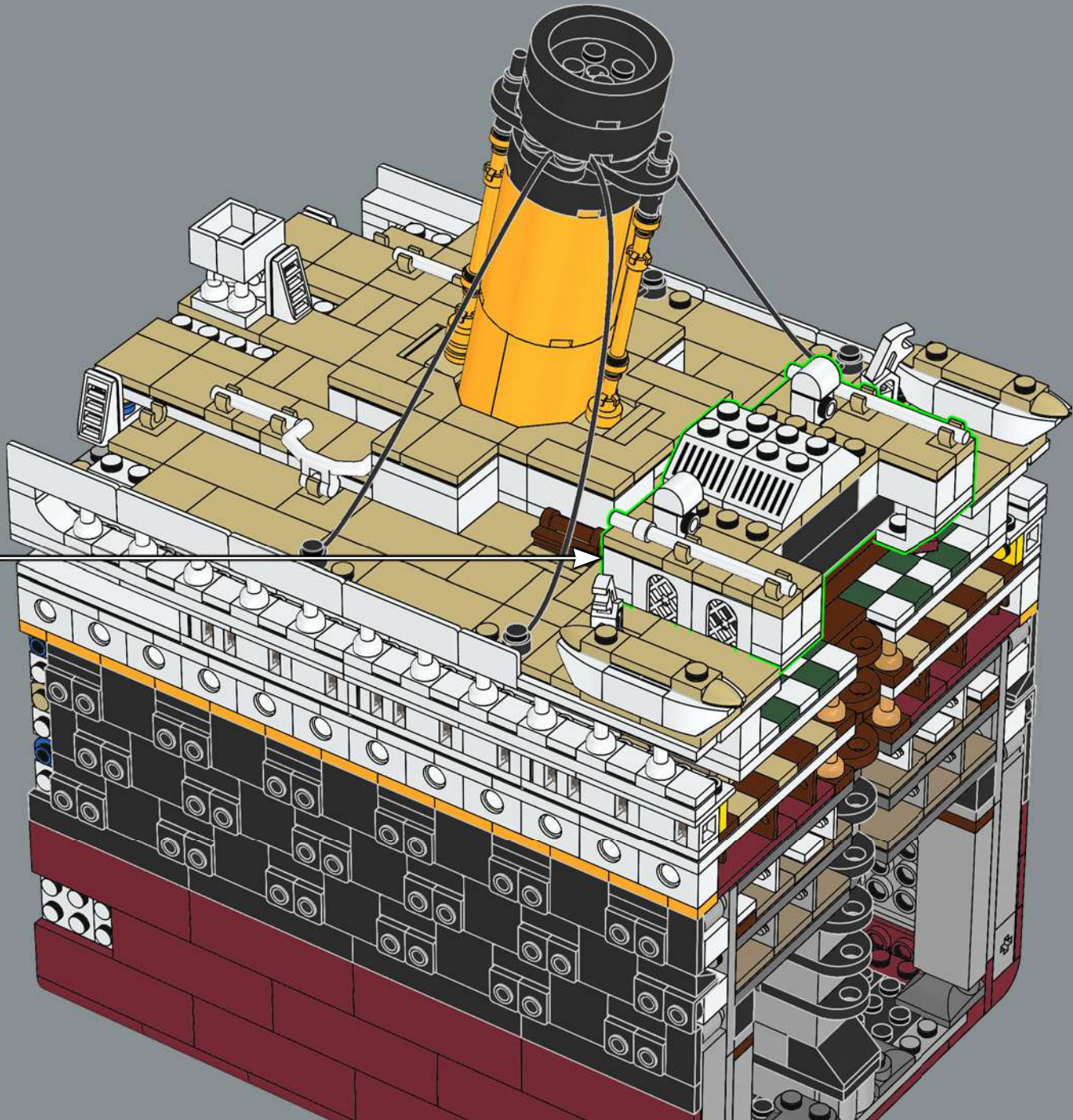

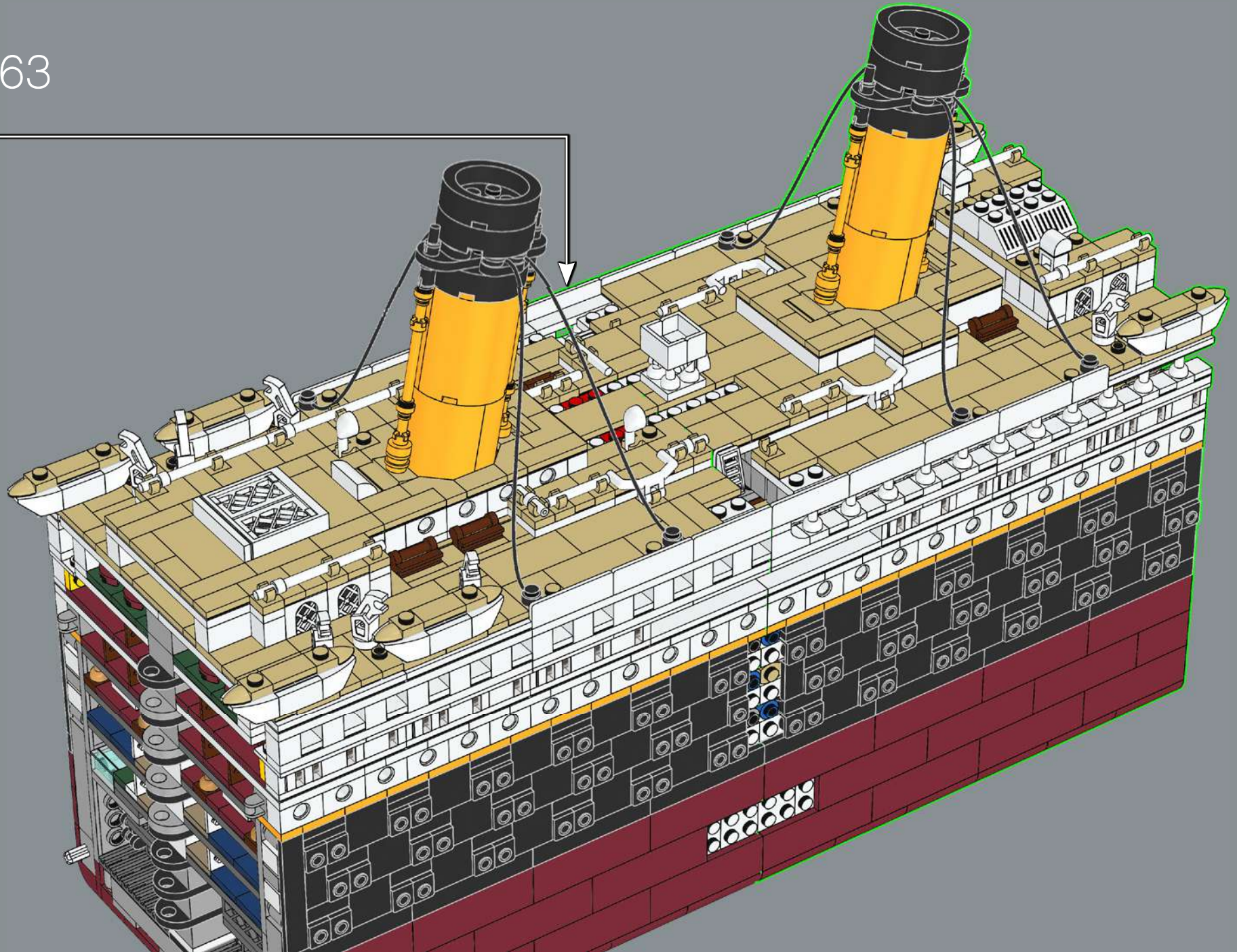

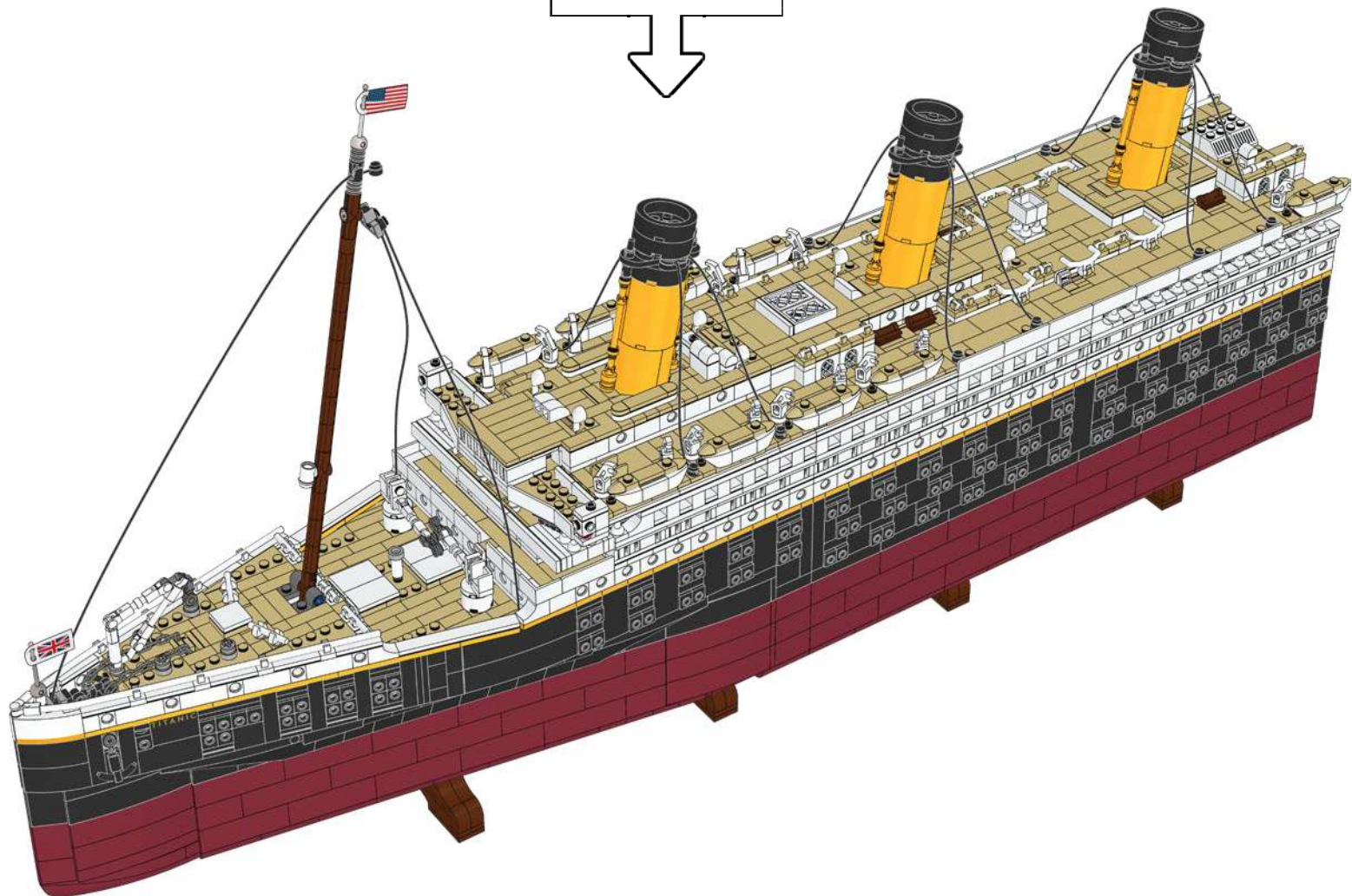
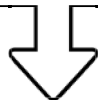

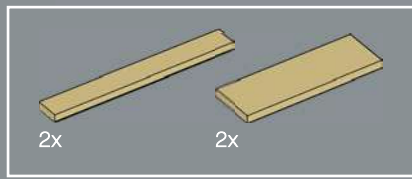

264

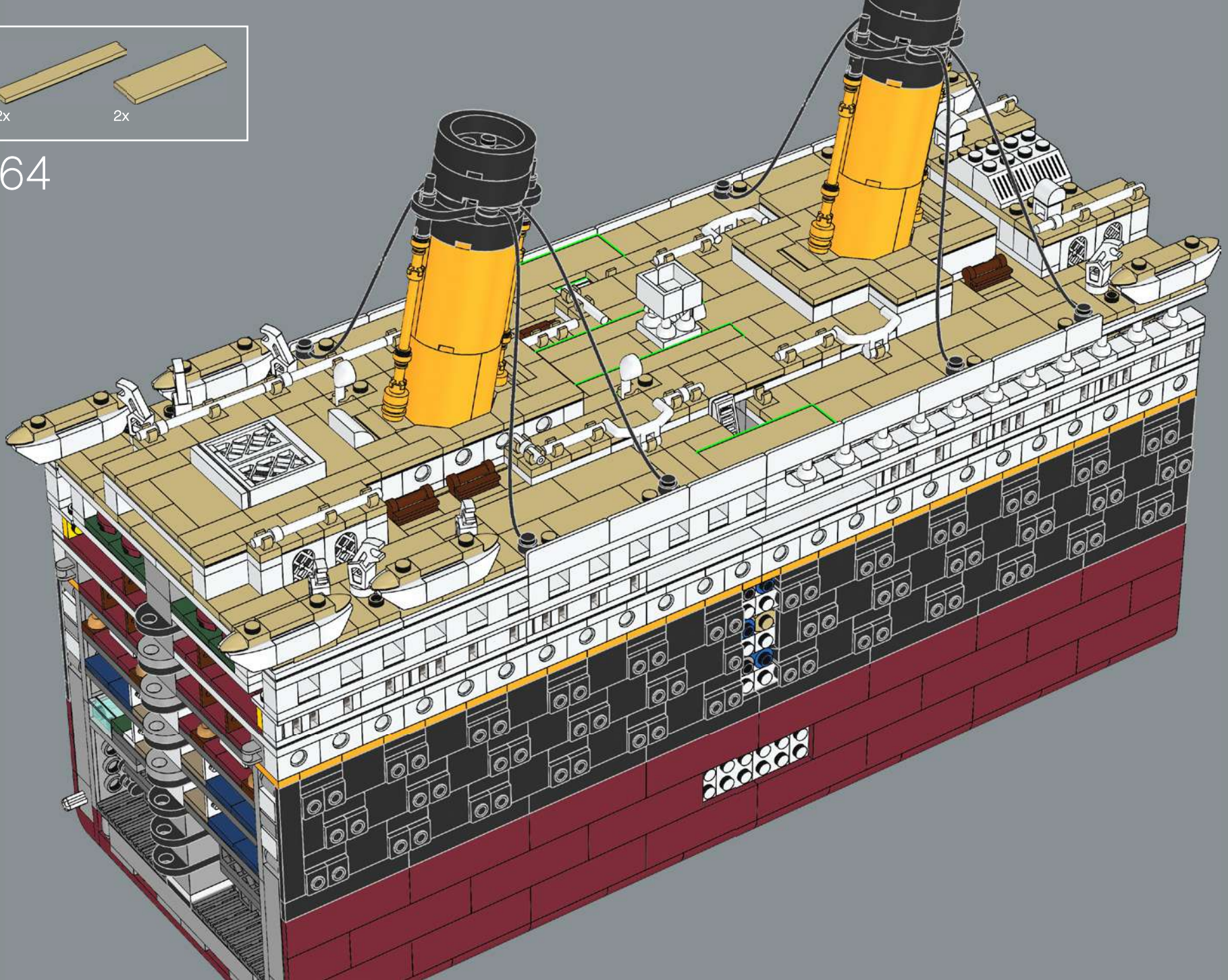

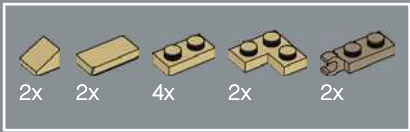

265

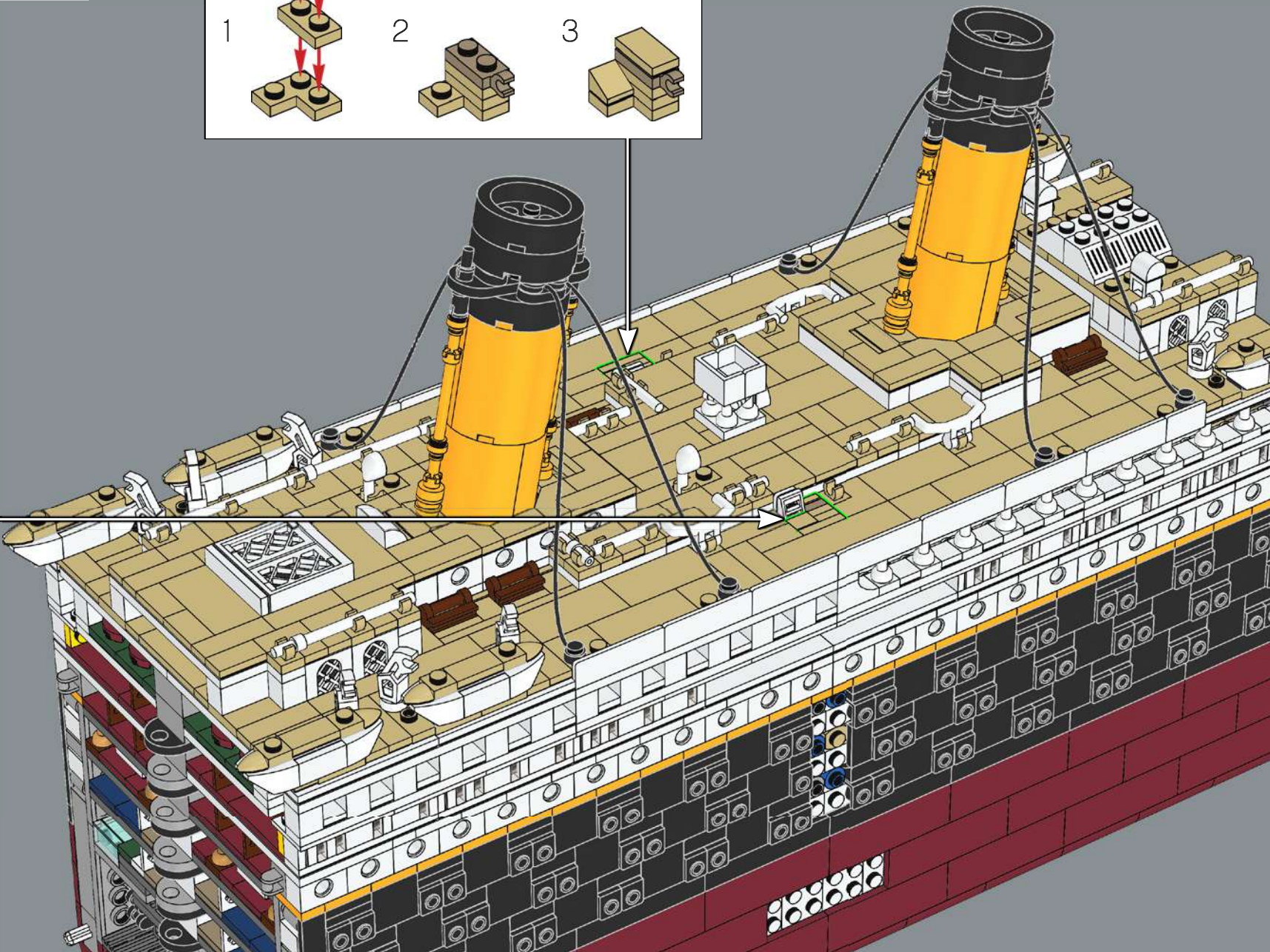
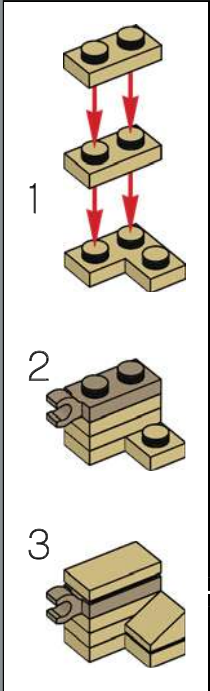
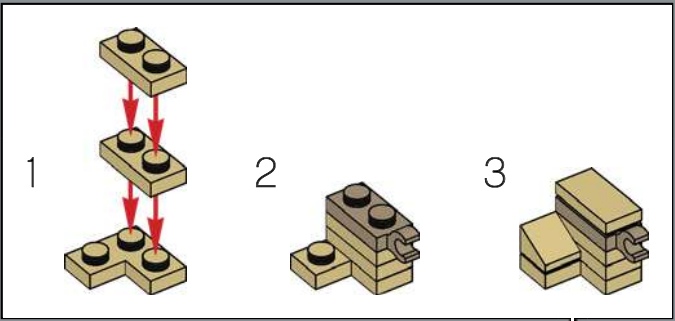

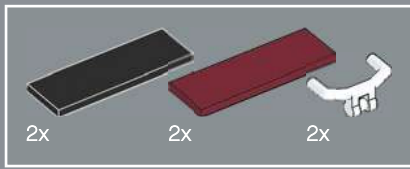

266

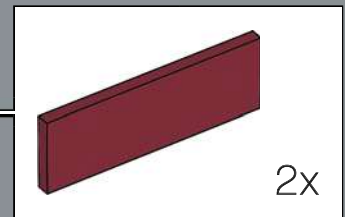
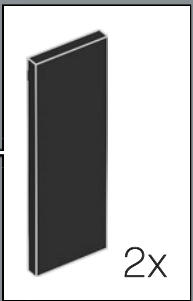
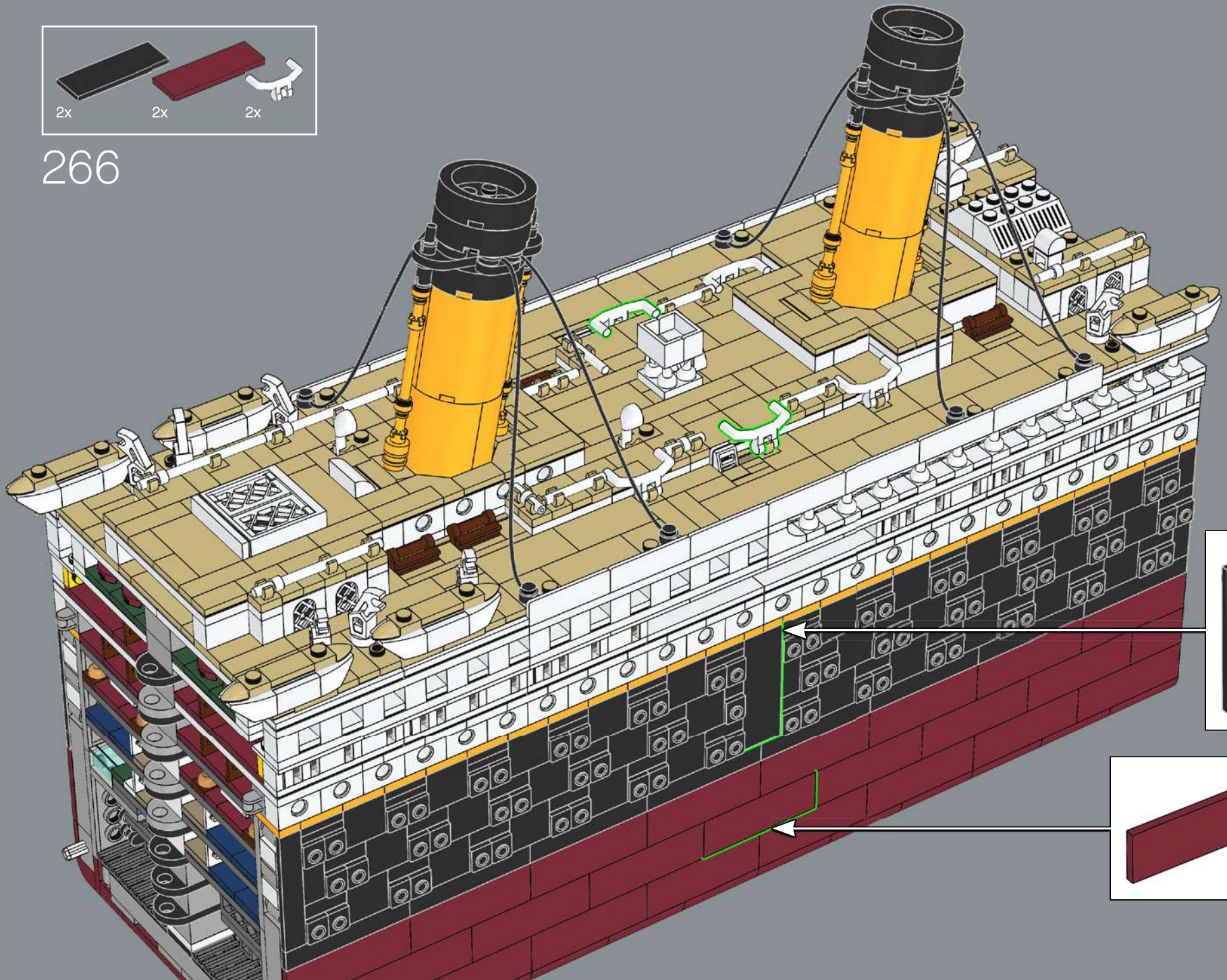

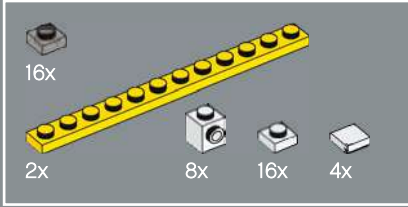
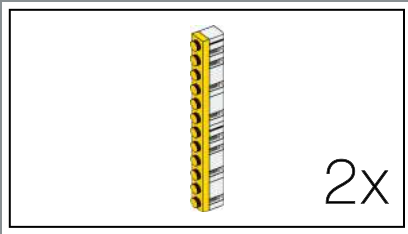

267

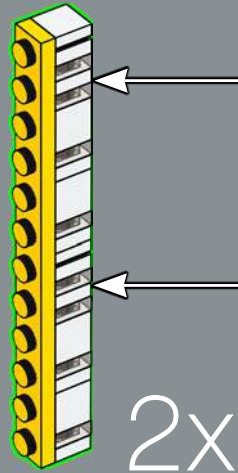
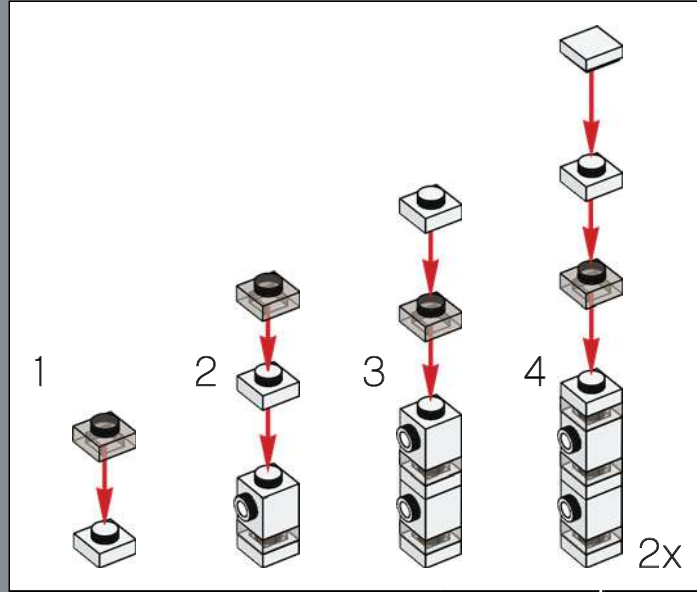

268

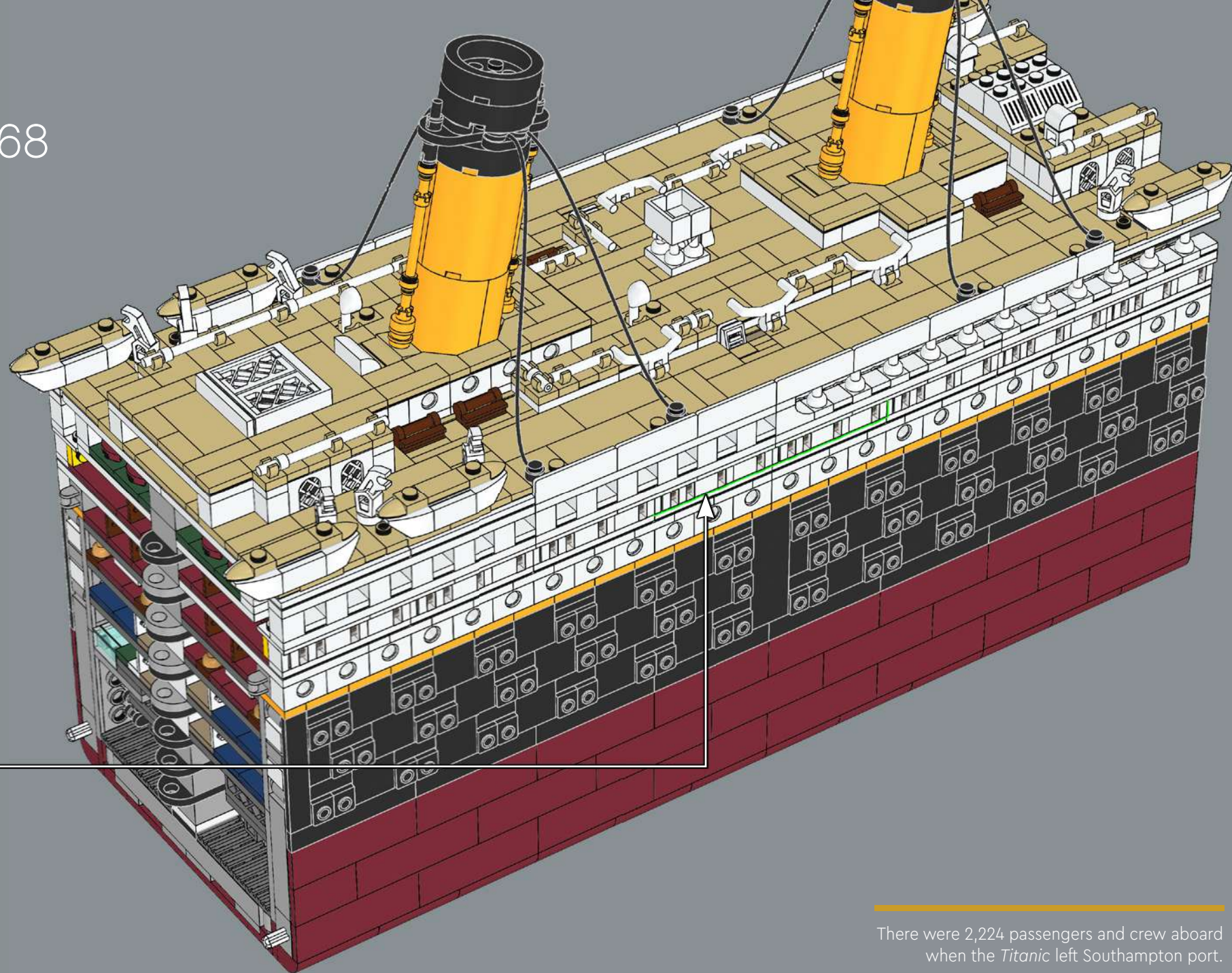

There were 2,224 passengers and crew aboard when the *Titanic* left Southampton port. 209

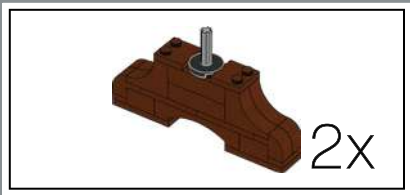

269

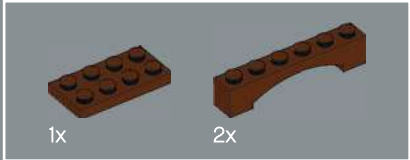

270

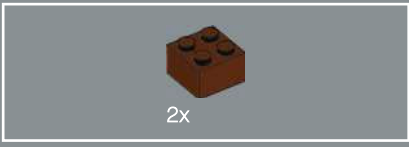
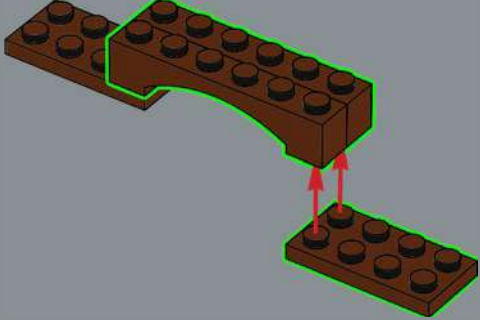

271

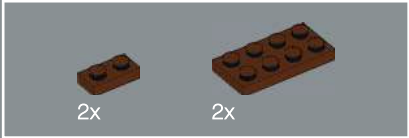
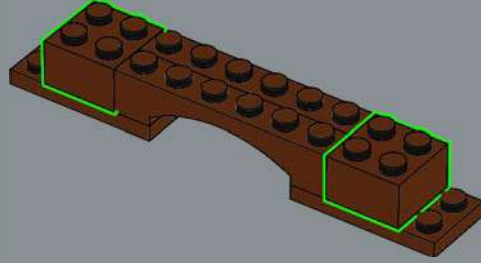

272

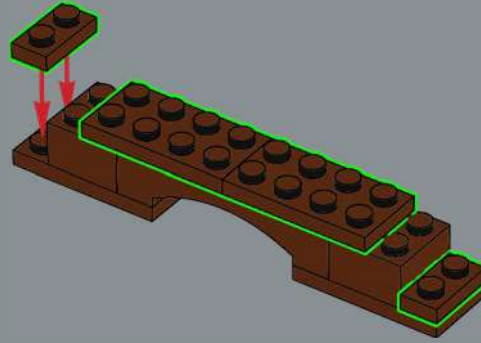



273

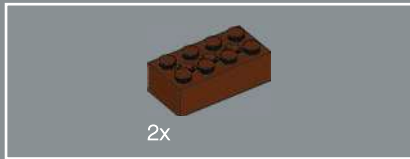
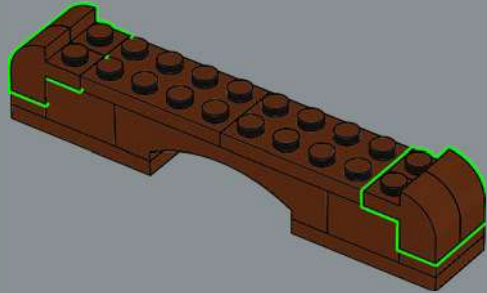

274

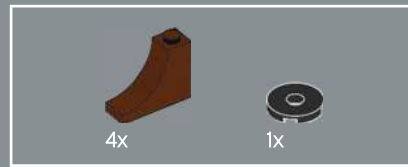
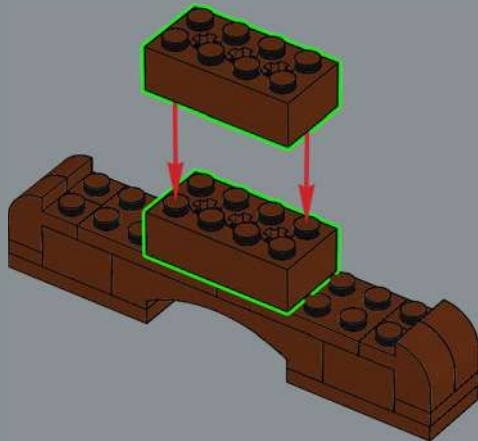

275

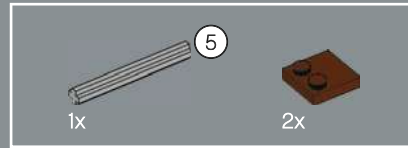
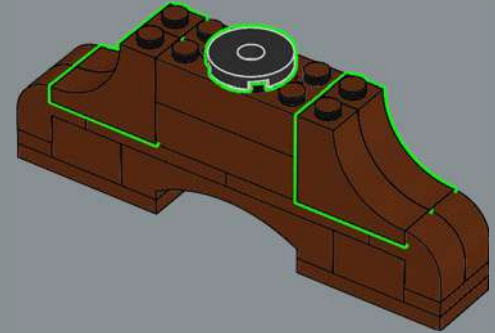

276

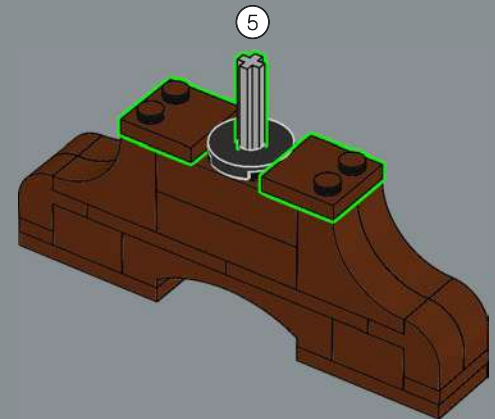

2x



277

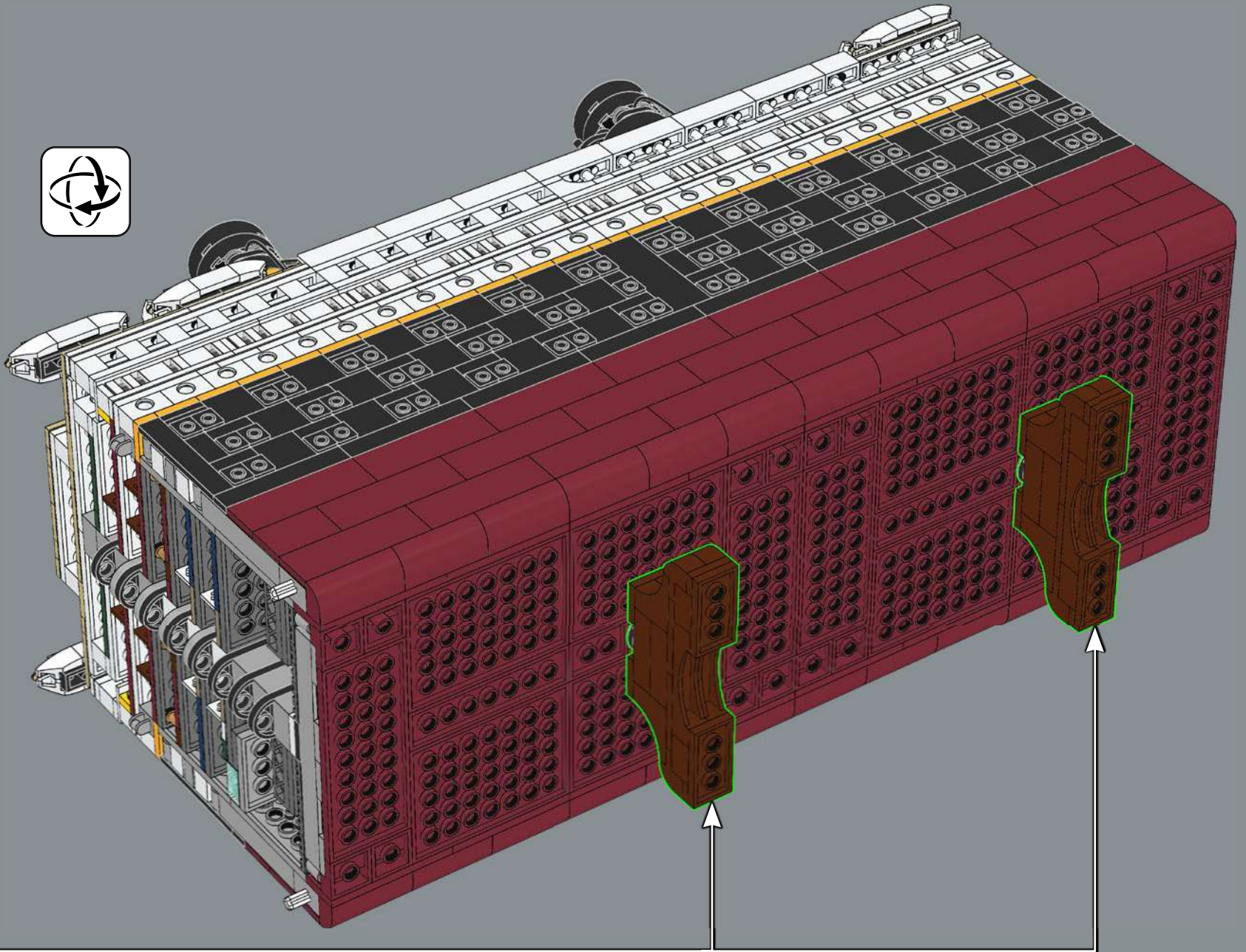

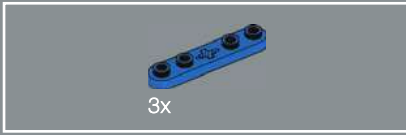
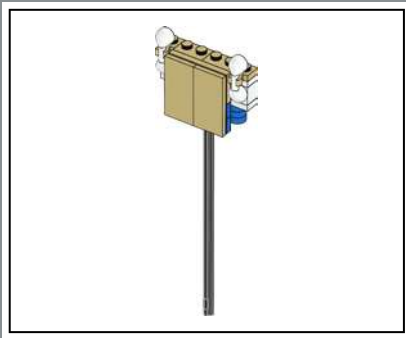

278

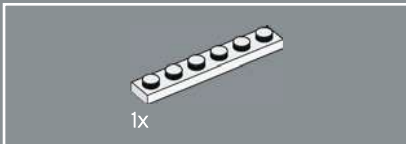
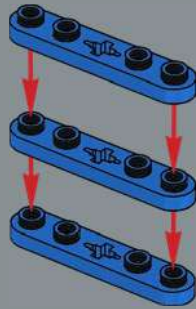

279

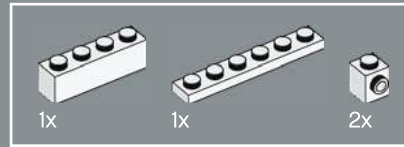
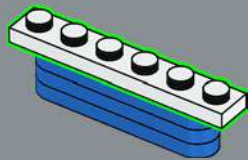

280

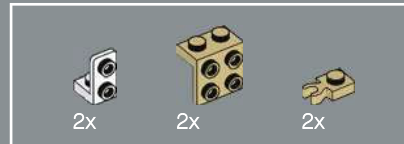
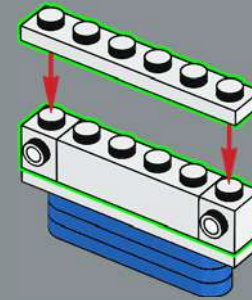

281

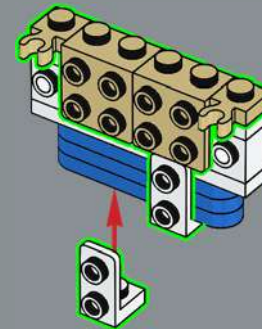

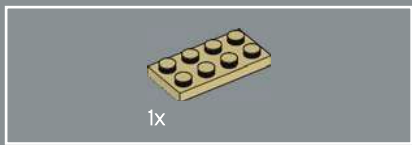

282

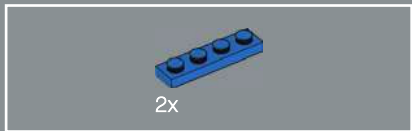
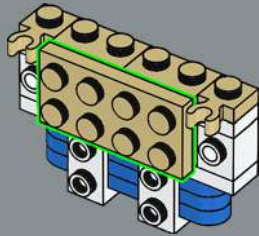

283

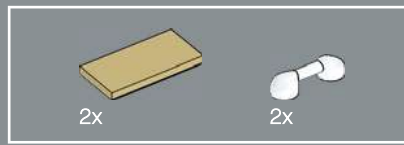
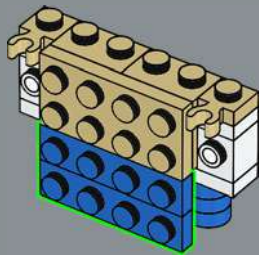

284

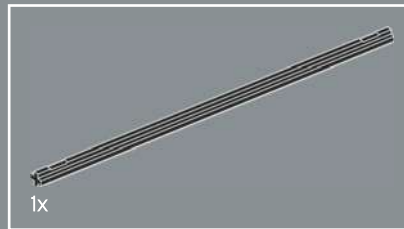
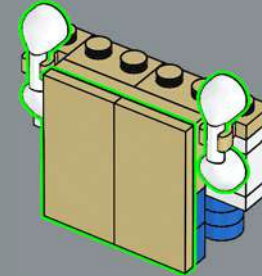

285

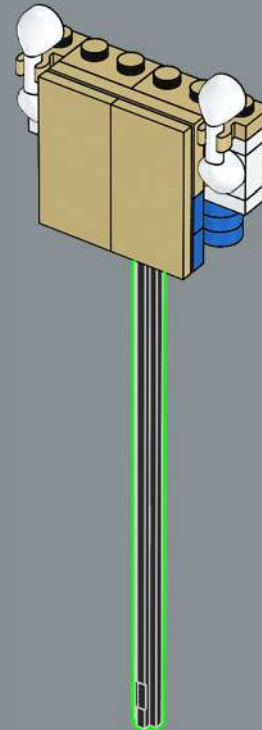

286

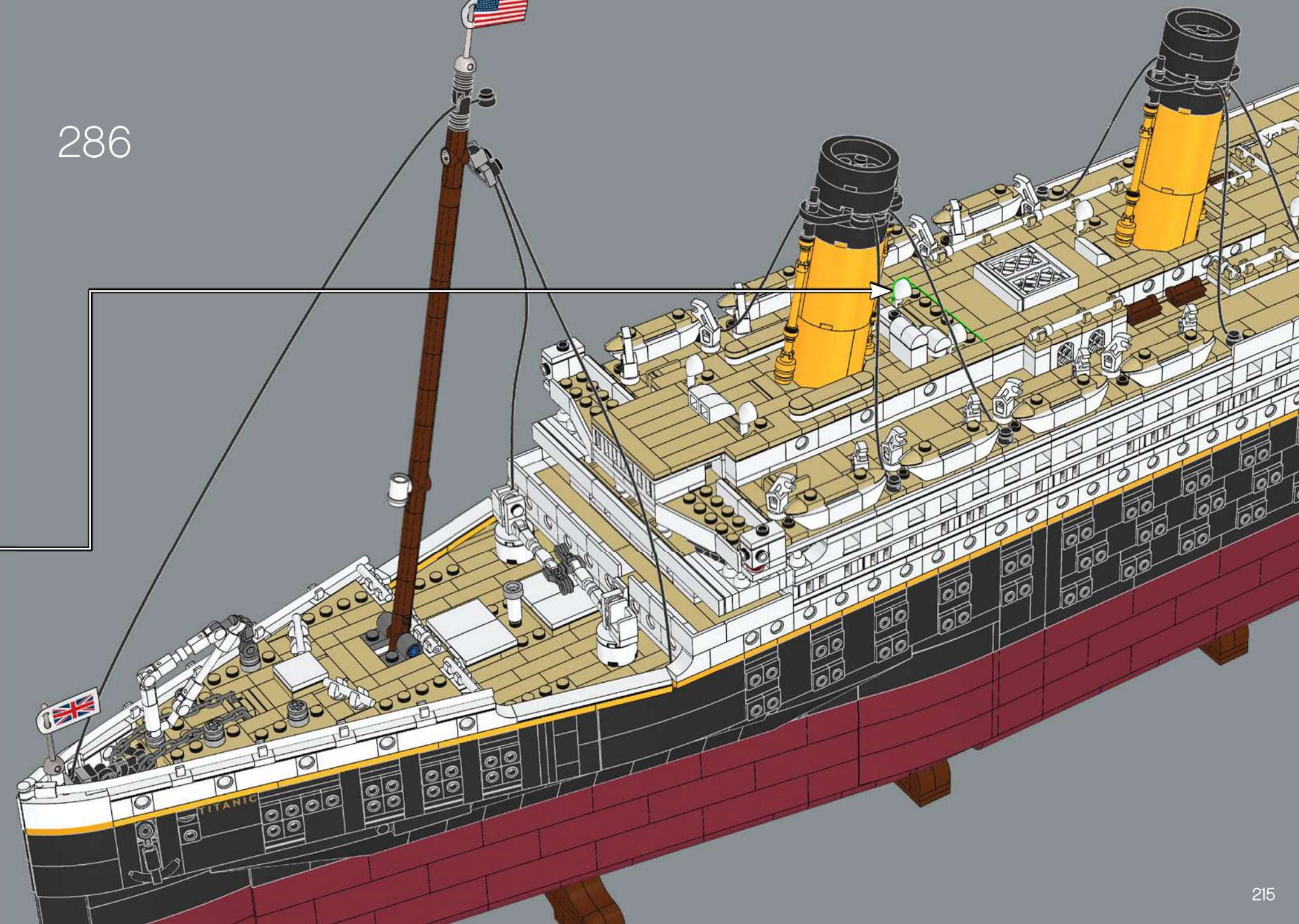

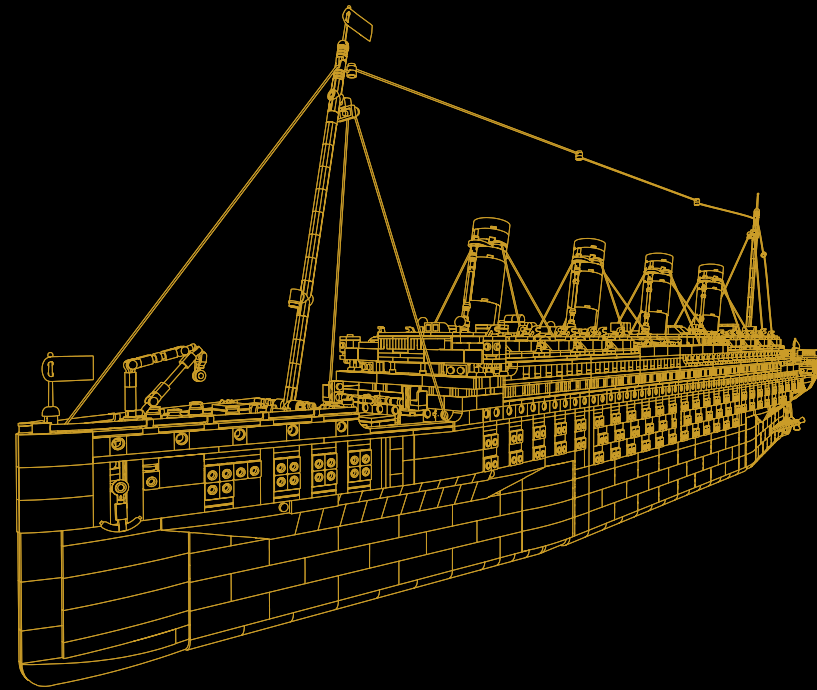

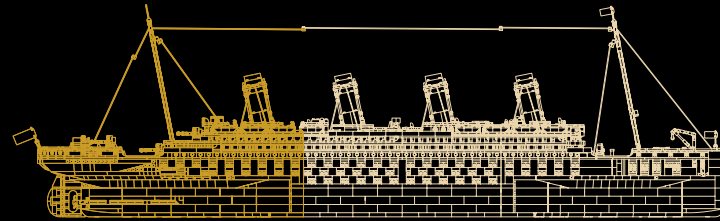

TITANIC

BOOK 3

THE UNSINKABLE OCEAN LINER

Though the RMS *Titanic* boasted many advanced safety features, outdated maritime safety regulations dictated that the liner only needed to have 20 lifeboats onboard: enough for just one third of her crew and passengers. When she collided with an iceberg at high speed just before midnight on April 14th, 1912 and quickly began to sink, the lack of lifeboats ensured only 710 people survived while more than 1,500 perished. As a direct result of the tragedy, new wide-ranging international safety standards were introduced, many of which are still in force today.

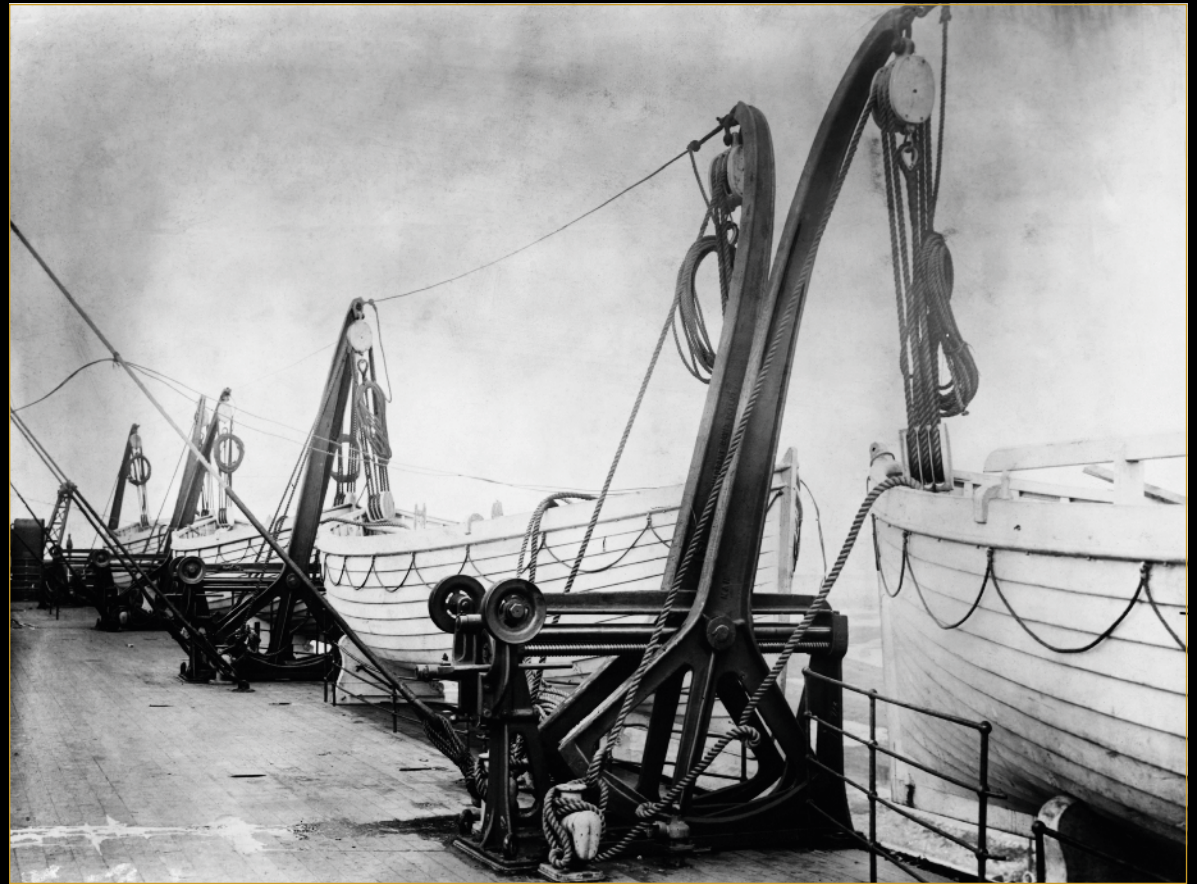

↑ Lifeboats in their davits on the *Titanic*.

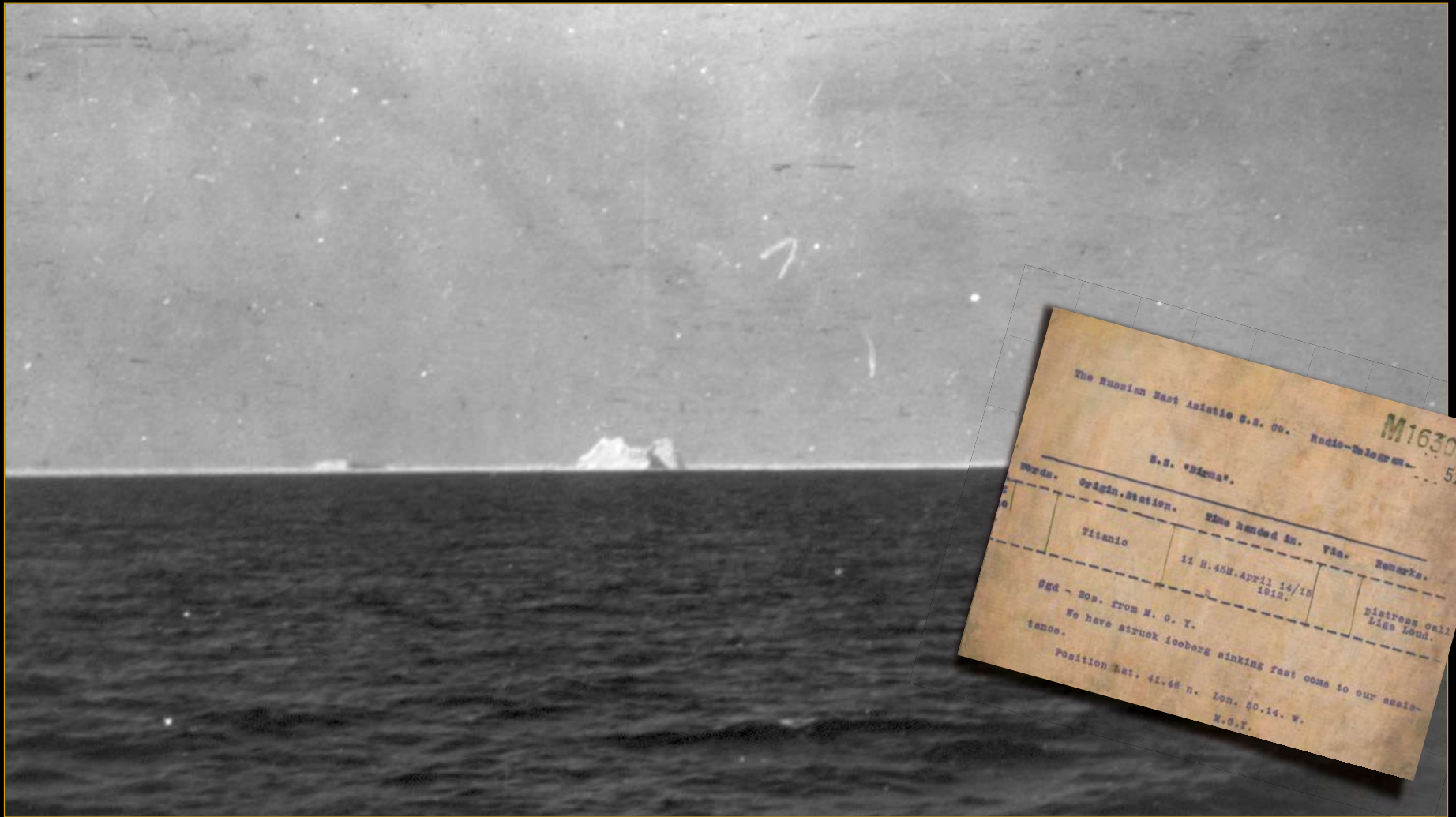

↑ The presumed location of the disaster taken from the SS Carpathia which picked up survivors from the Titanic.

↗ A telegram transmitted from RMS Titanic to the SS Birma requesting assistance.

IMPRESSIVE SCALE

At its launch, the *Titanic* was the largest man-made vessel ever constructed. She was over 269 meters (882.9 ft.) long and measured 53.3 meters (175 ft.) from the bottom of the hull to the top of her smokestacks. Likewise, the LEGO® version of the RMS *Titanic* is the longest LEGO model created so far and one of the most intricate.

The LEGO version of the Titanic is built at 1:200 scale, the same scale as the LEGO Architecture Statue of Liberty set.

The Titanic was 11 times as long as the blue whale, the largest animal ever known to have lived on Earth.

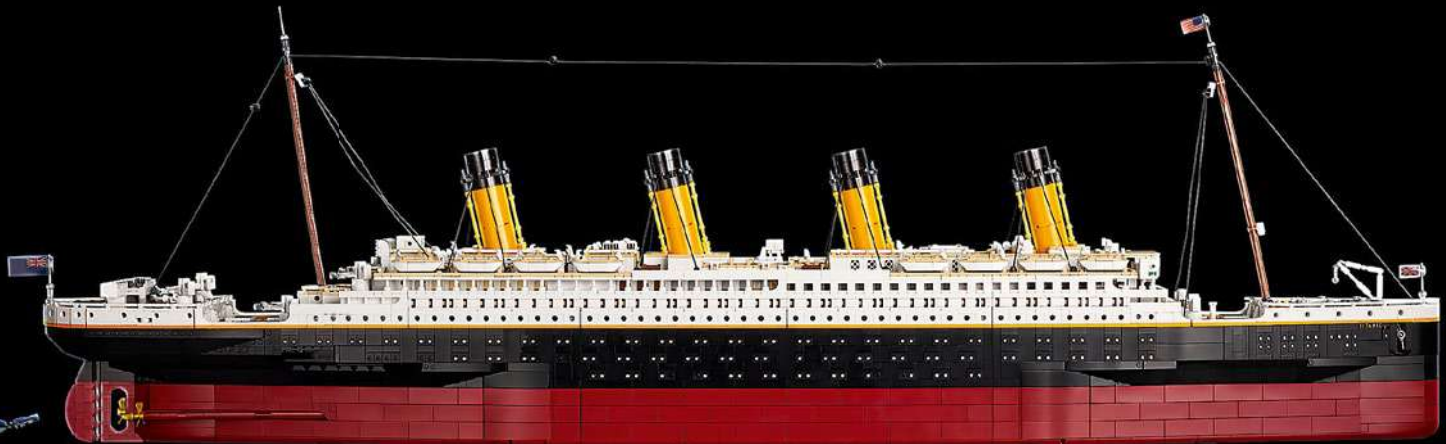



[LEGO.com/brickseparator](https://www.LEGO.com/brickseparator)

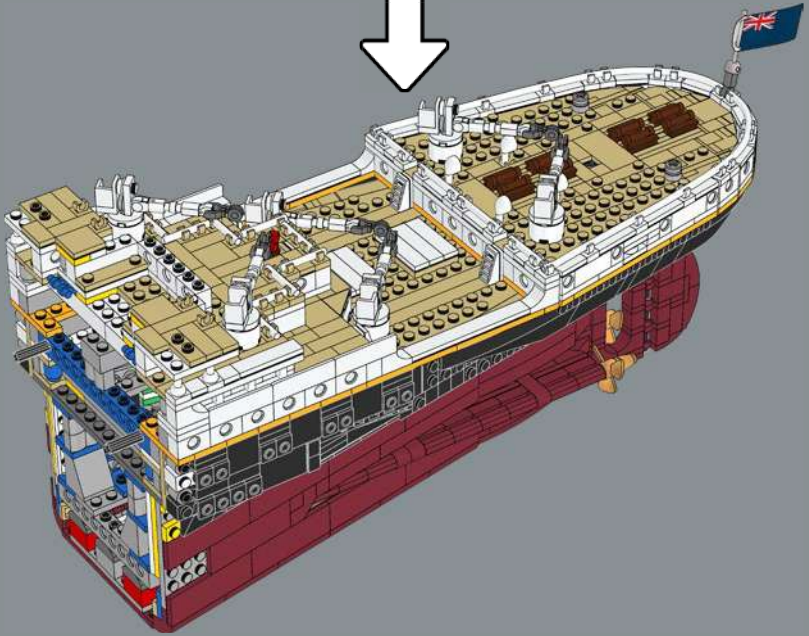
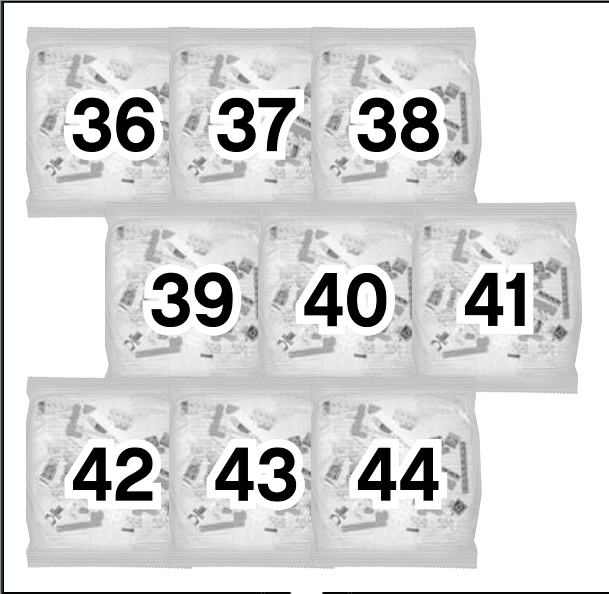
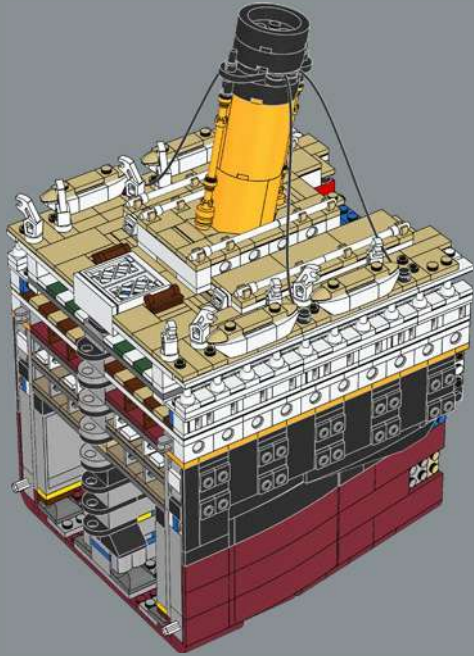
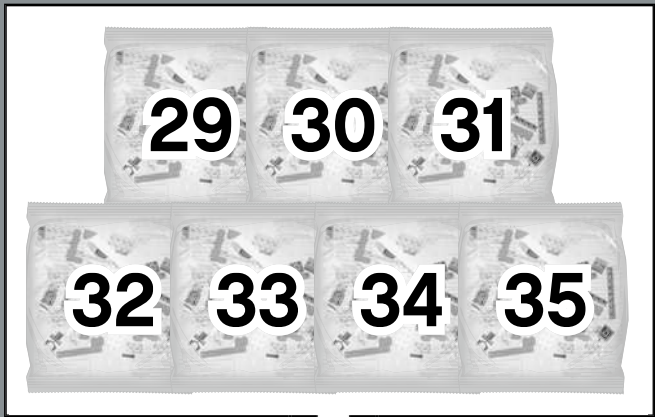

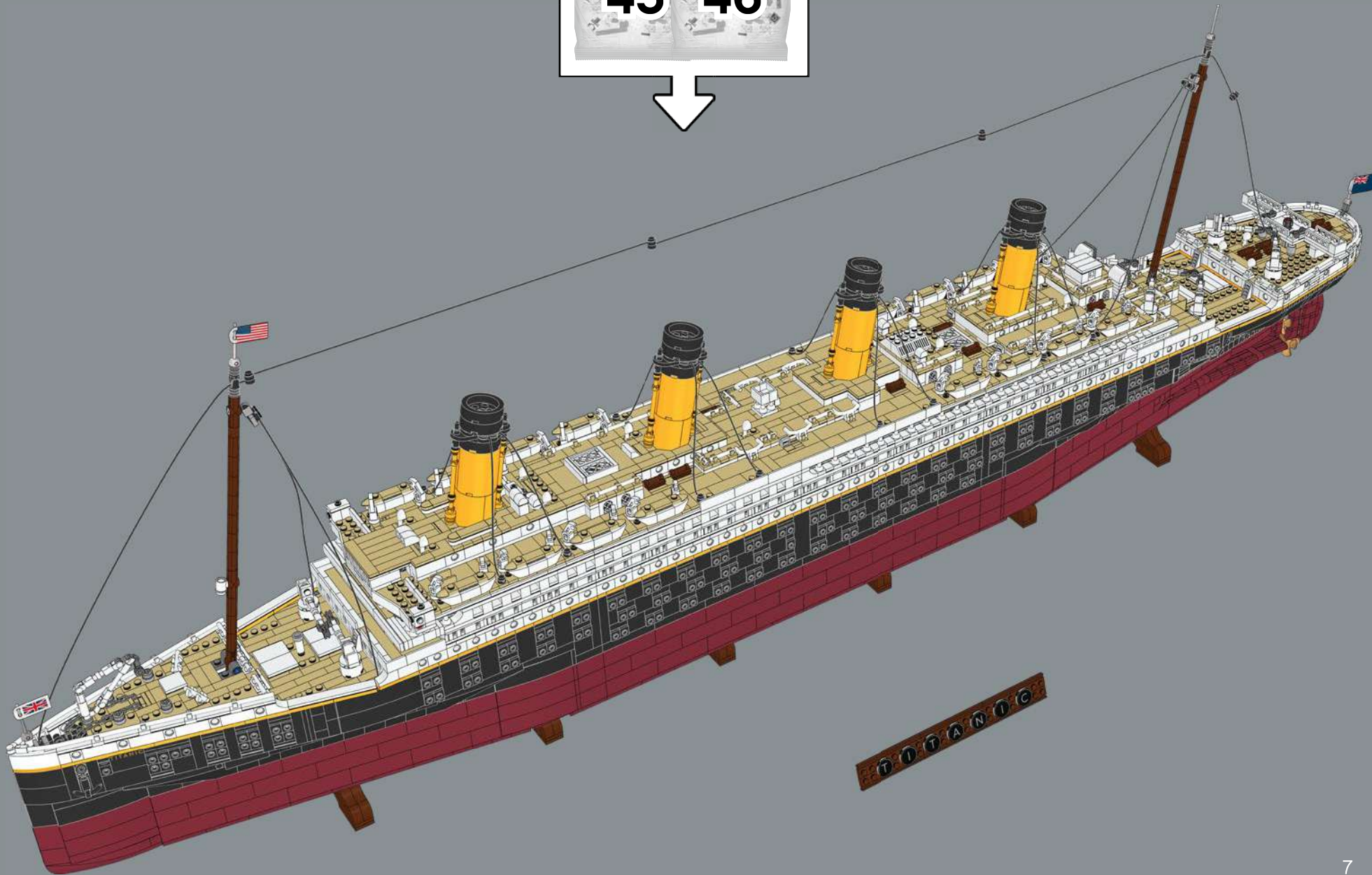
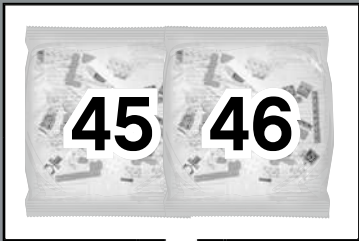

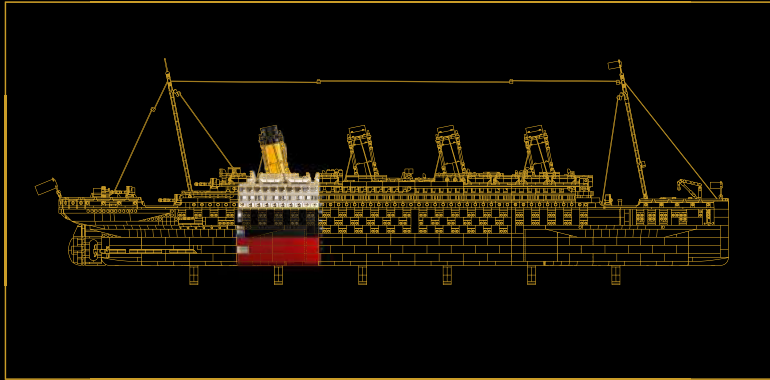

SECTION 5:

FUNNEL & ENGINE ROOM

In this section the model narrows as it tapers towards the propellers and rudder at the stern of the ship. You will also build the model's final funnel. On the real *Titanic*, this funnel was not connected to any boilers but was included in the design of the ship to make it feel more beautiful and complete.

↓ At the top of this section, you will add the ship's reading room and some of its 2nd class cabins.



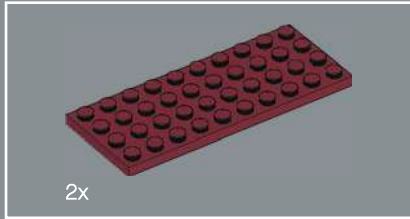
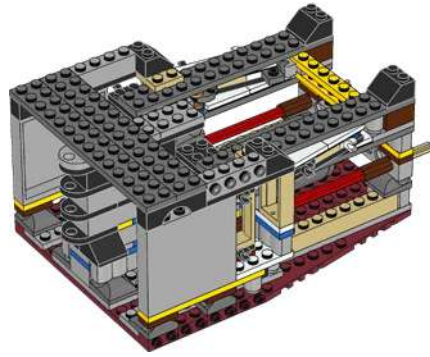
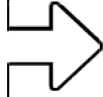

2x

1

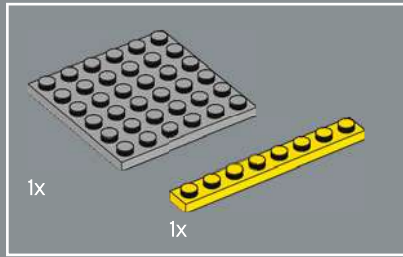
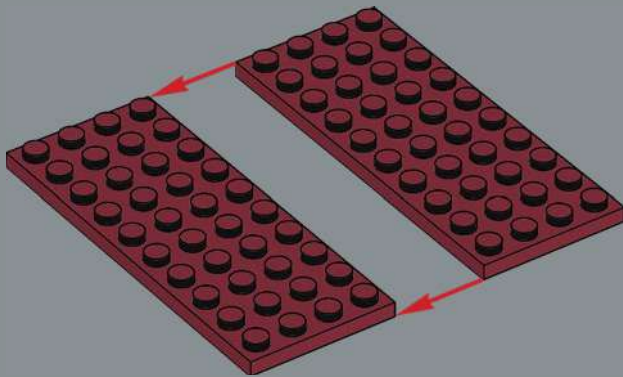

2

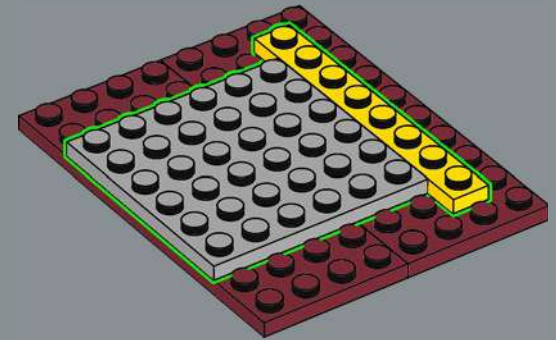

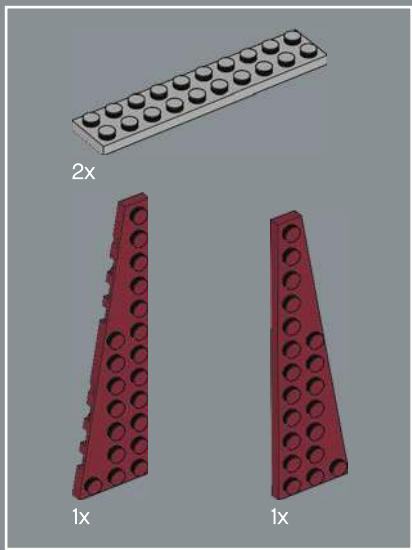

3

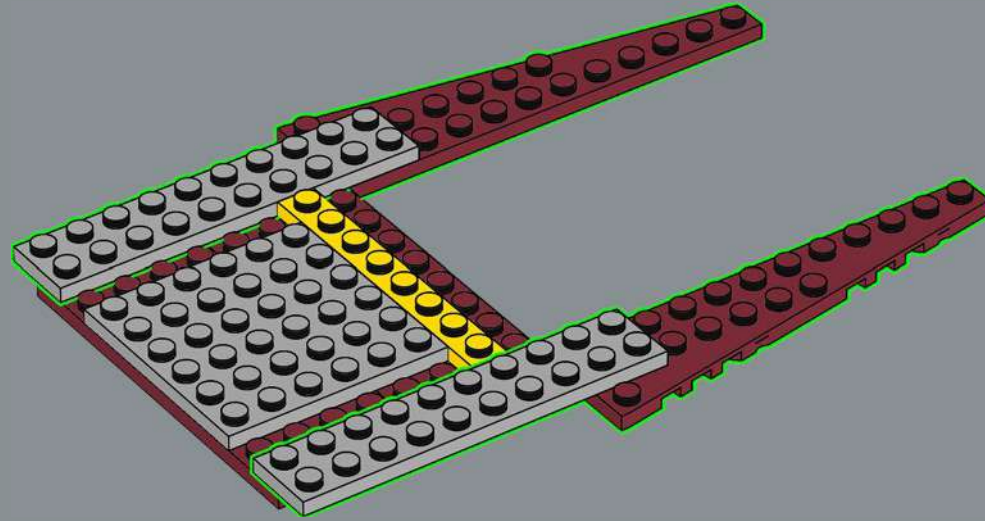

4

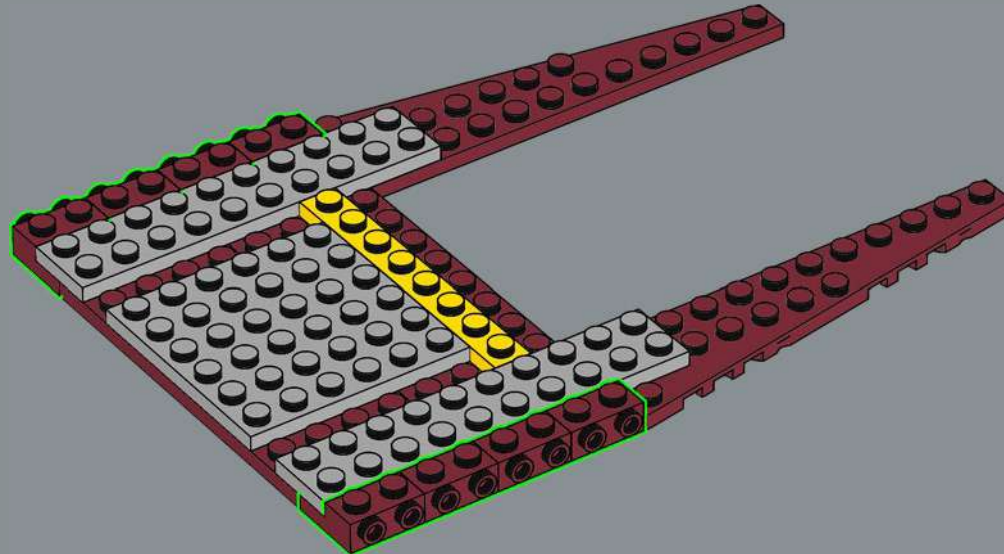

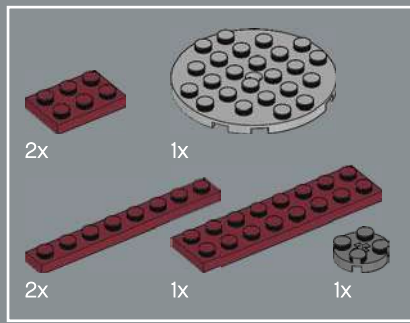

5

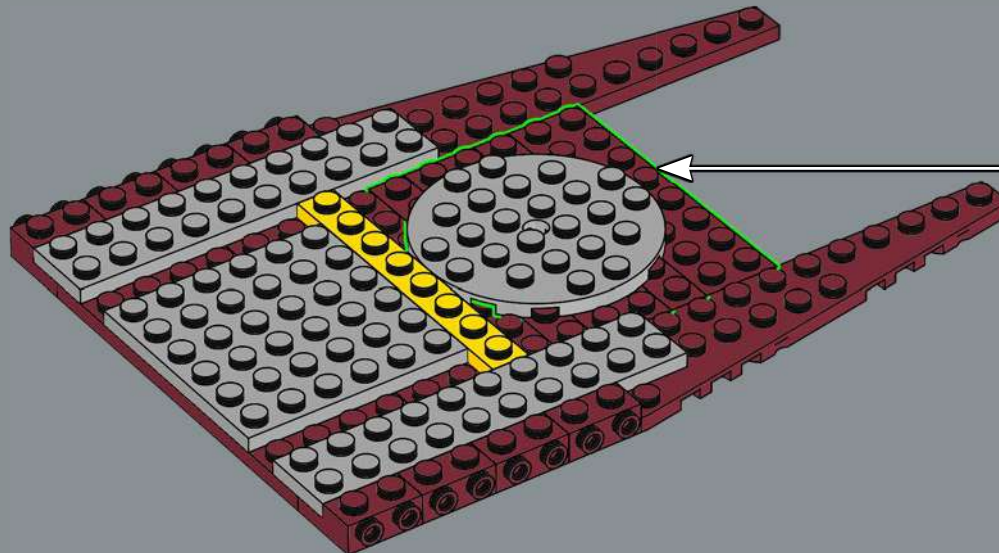
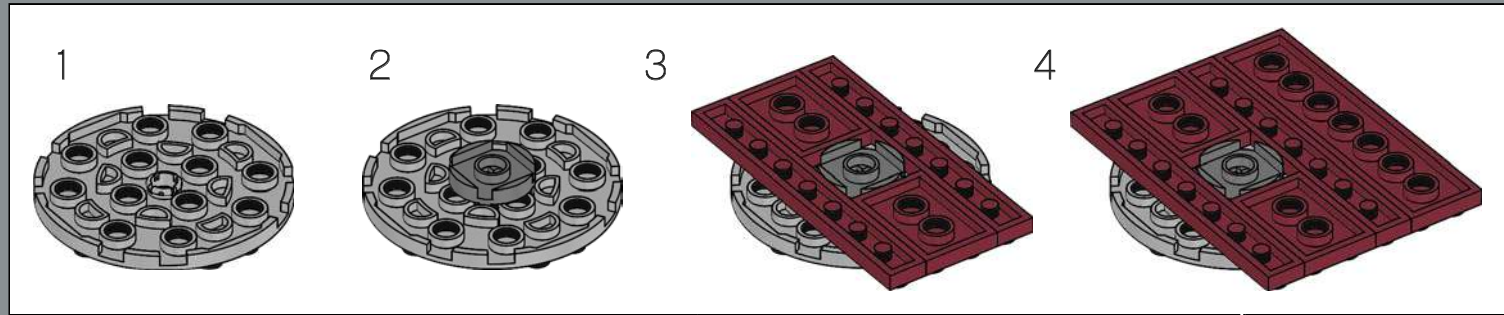

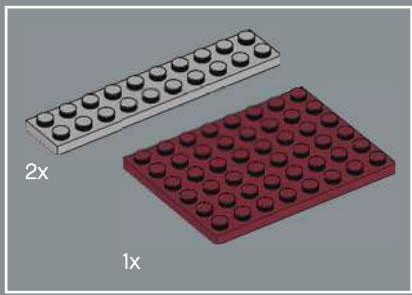

6

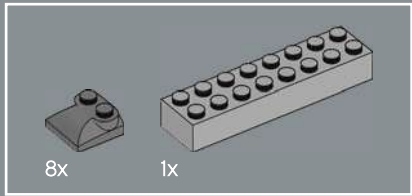
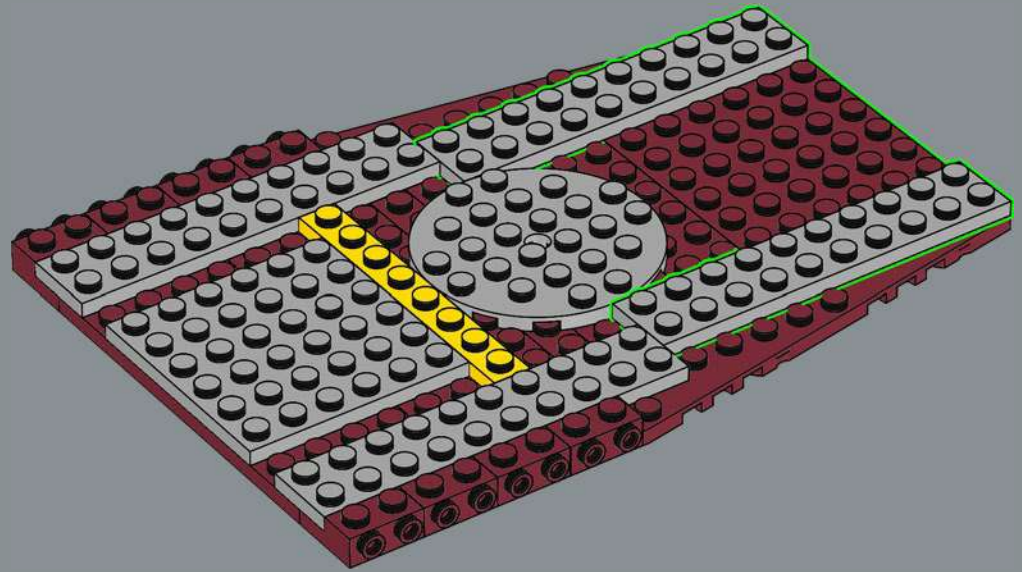

7

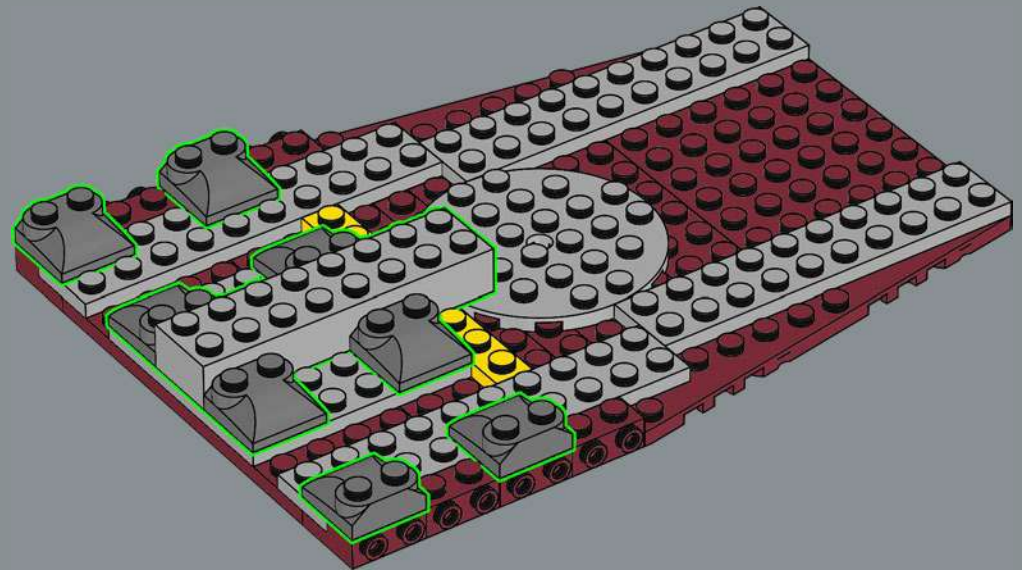



8

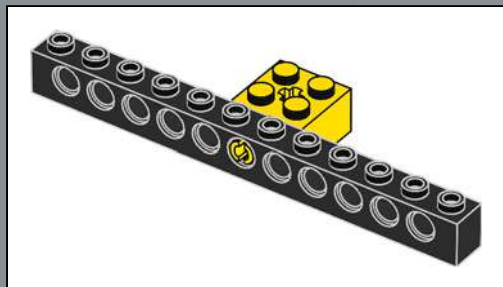
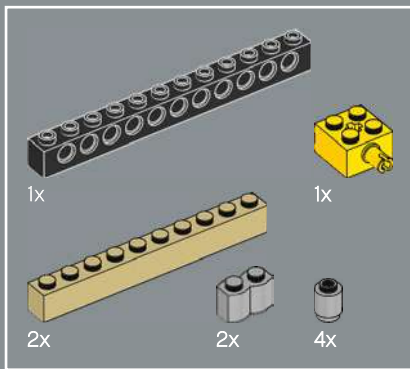
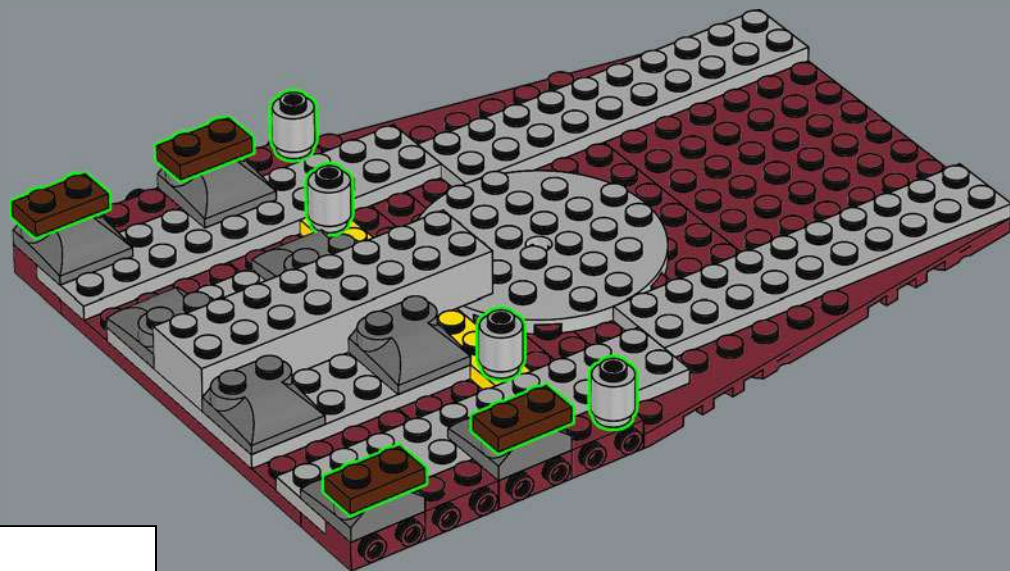

9

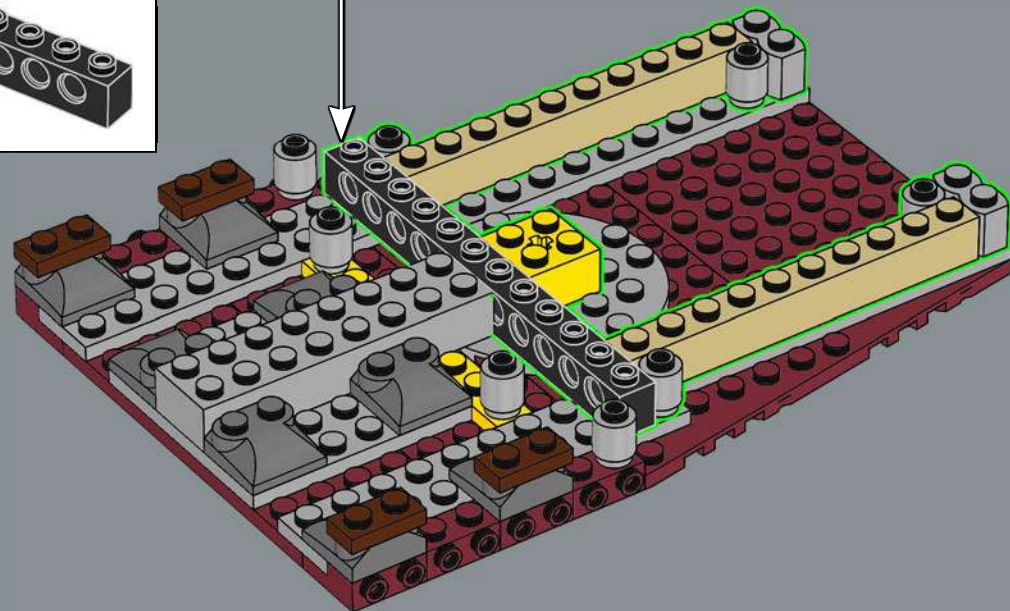

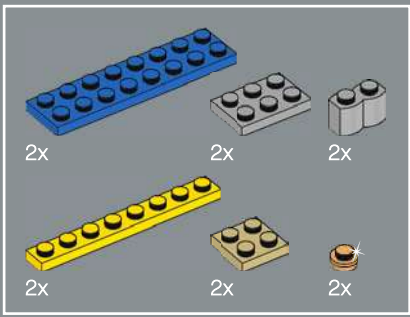

10

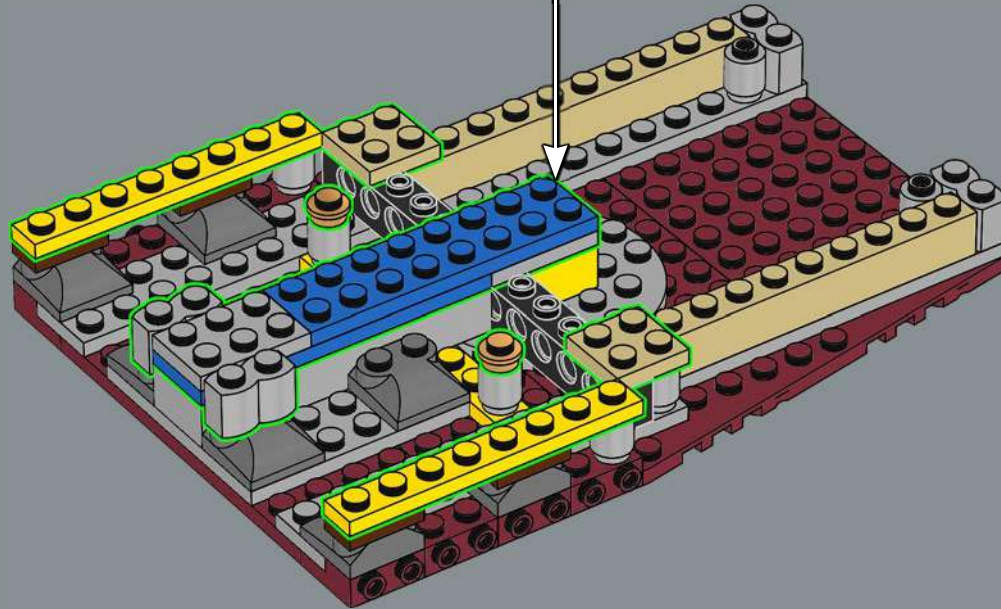
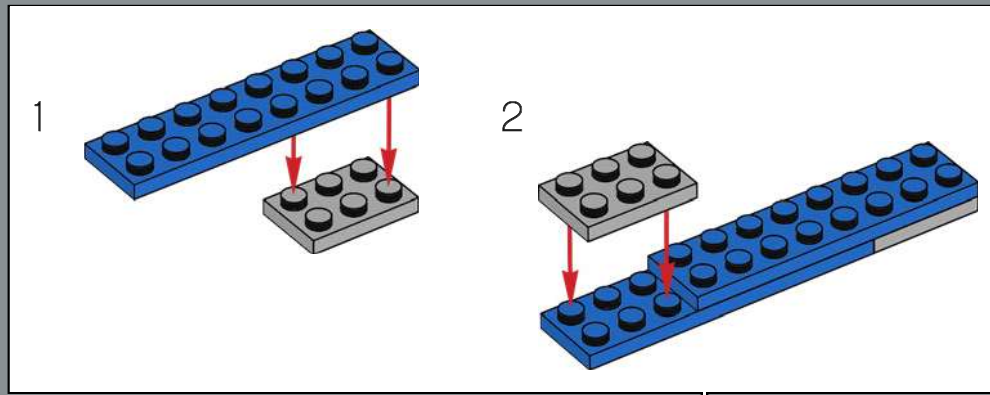

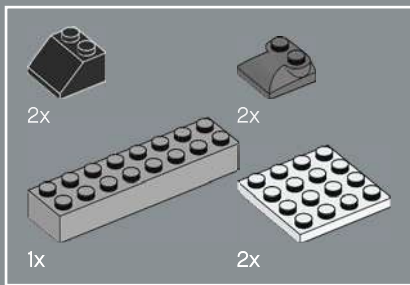

11

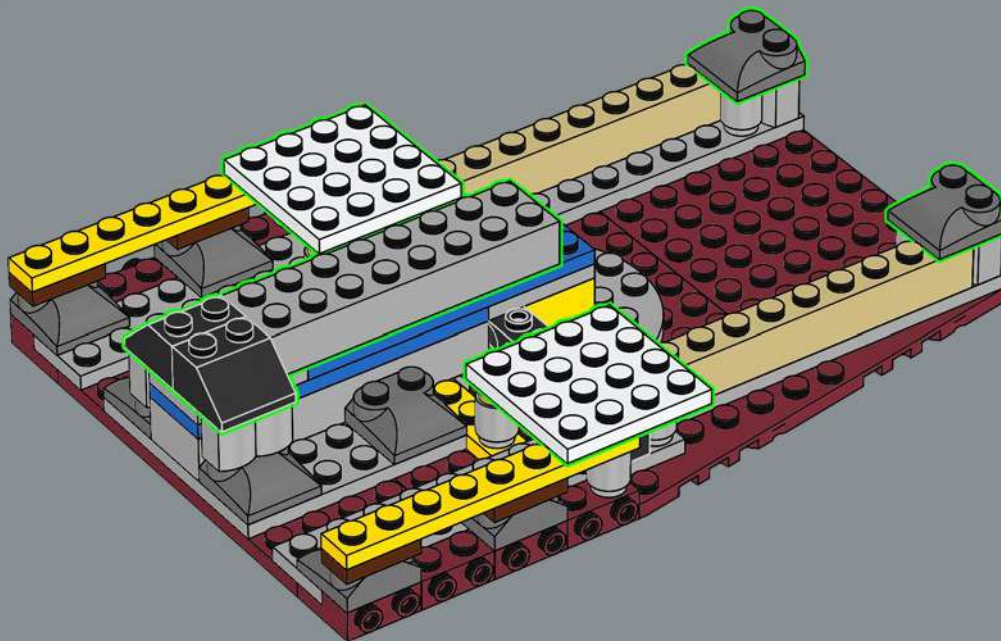



12

1

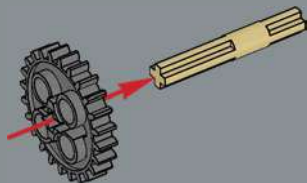

2

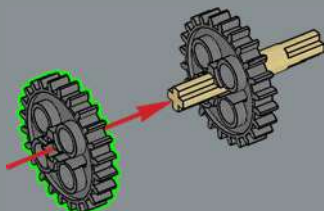

3

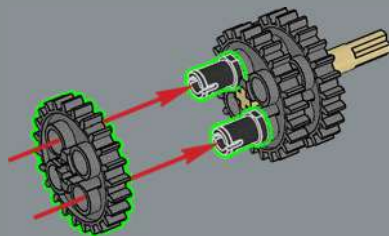

4

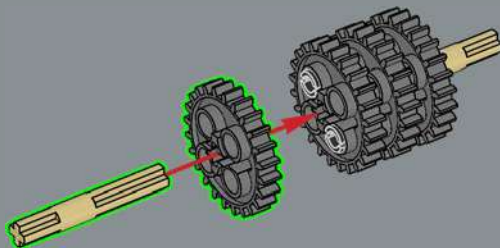

5

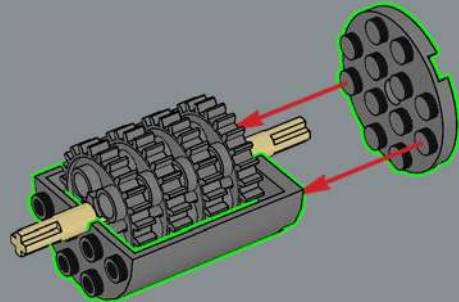

6

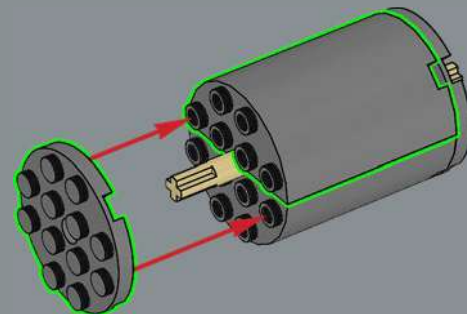

7

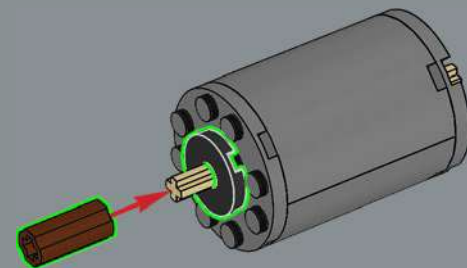

8

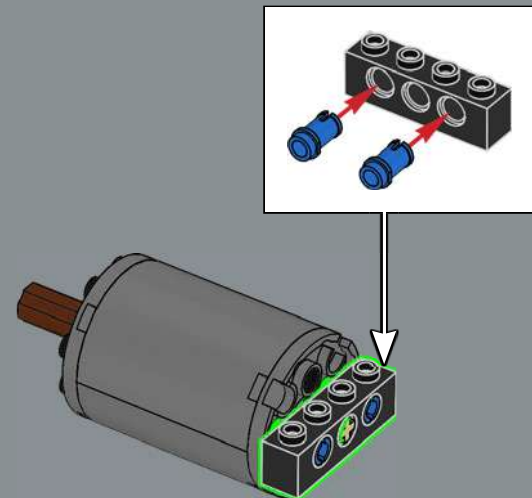

The *Titanic*'s electrical plant was capable of producing more power than an average city power station of the time.

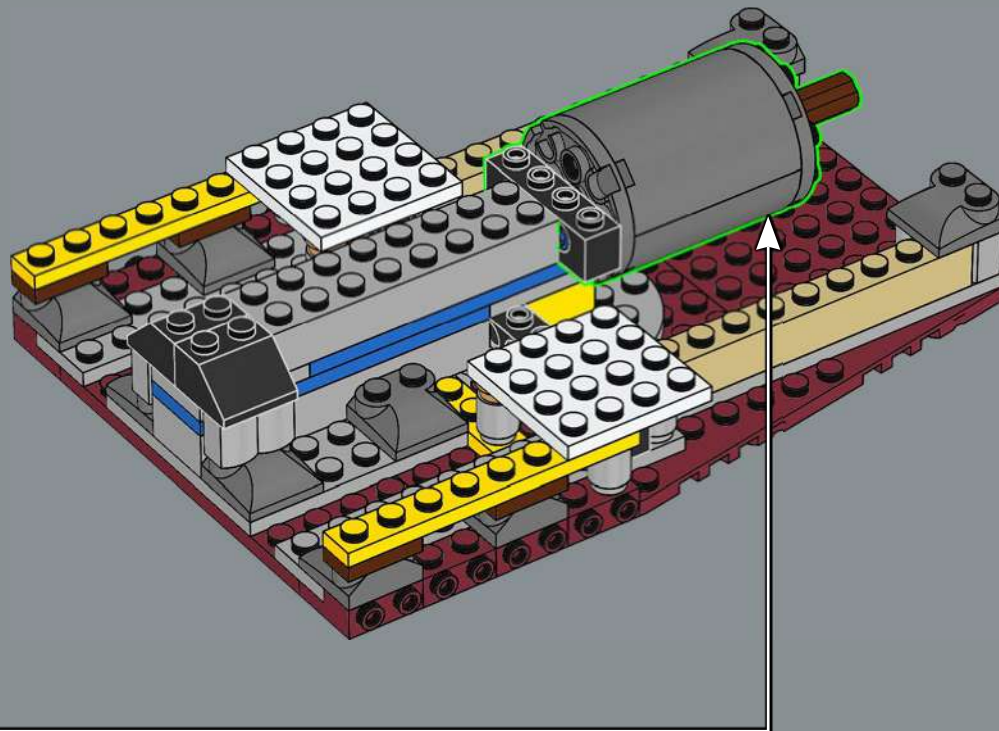

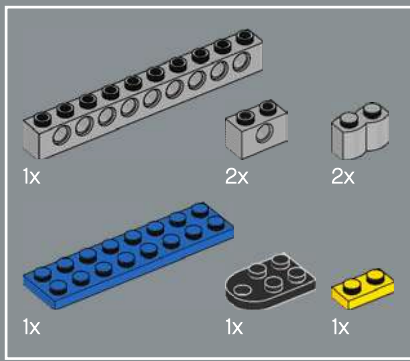

13

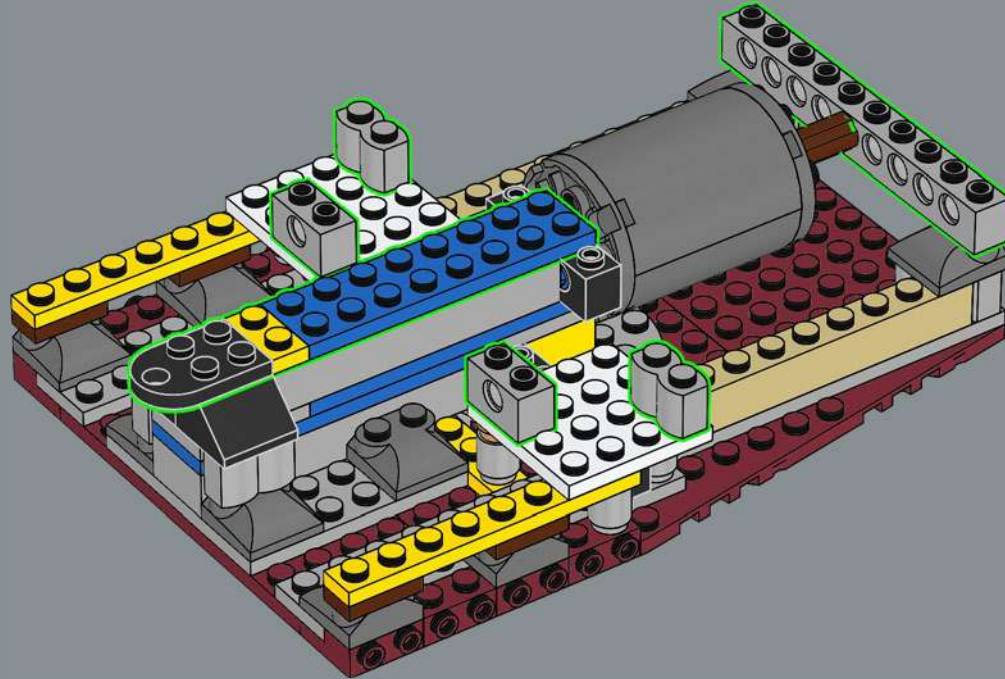

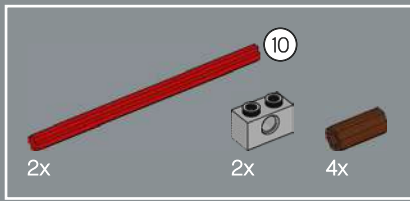

14

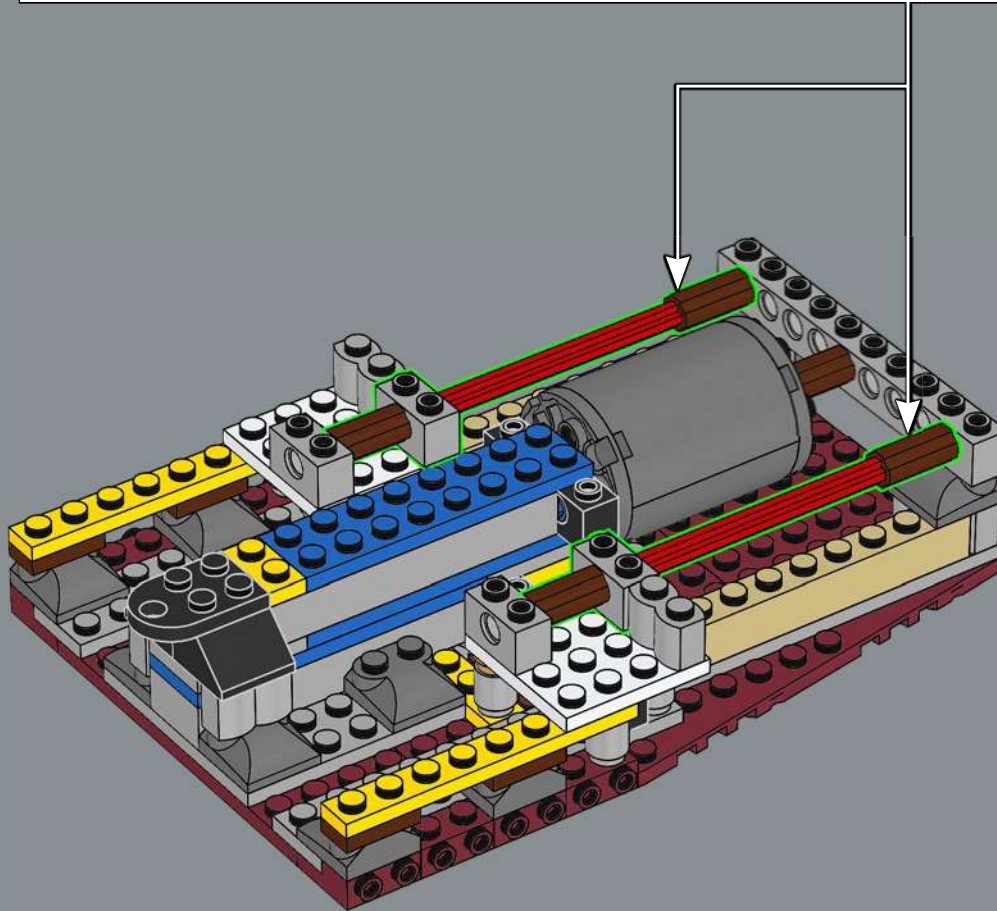
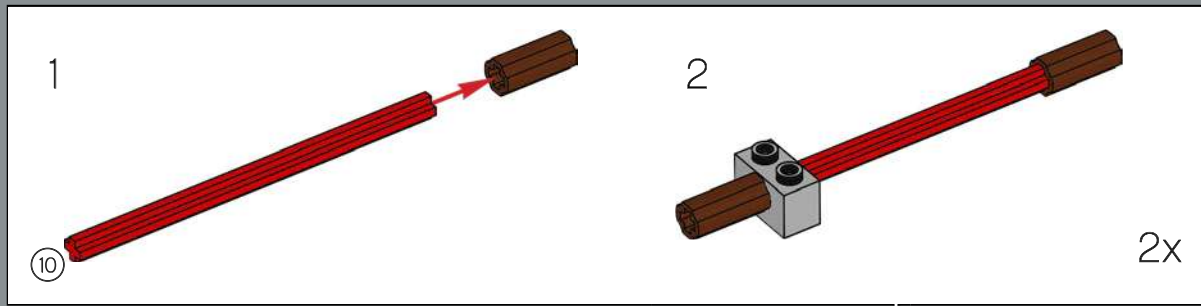



15

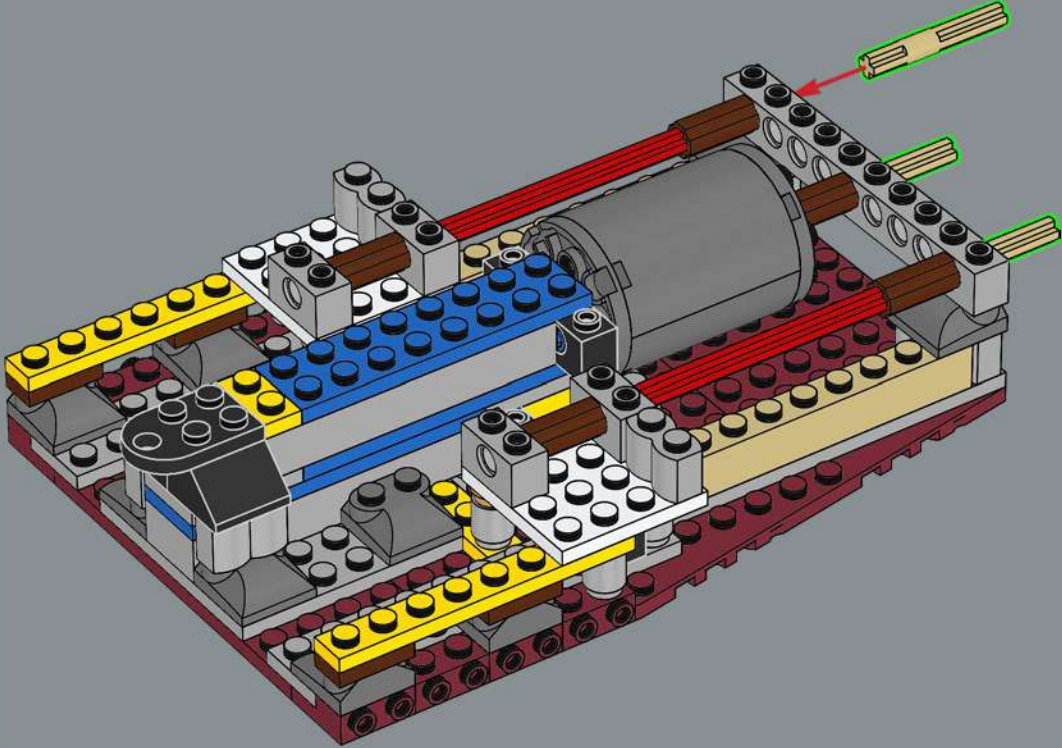

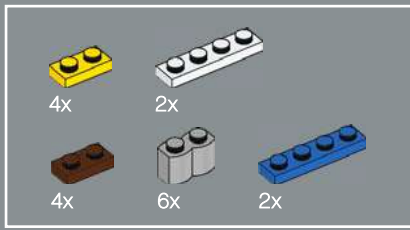

16

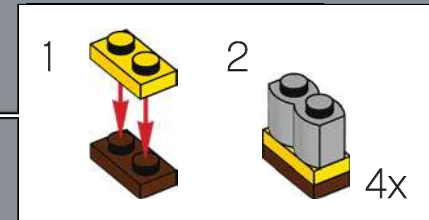
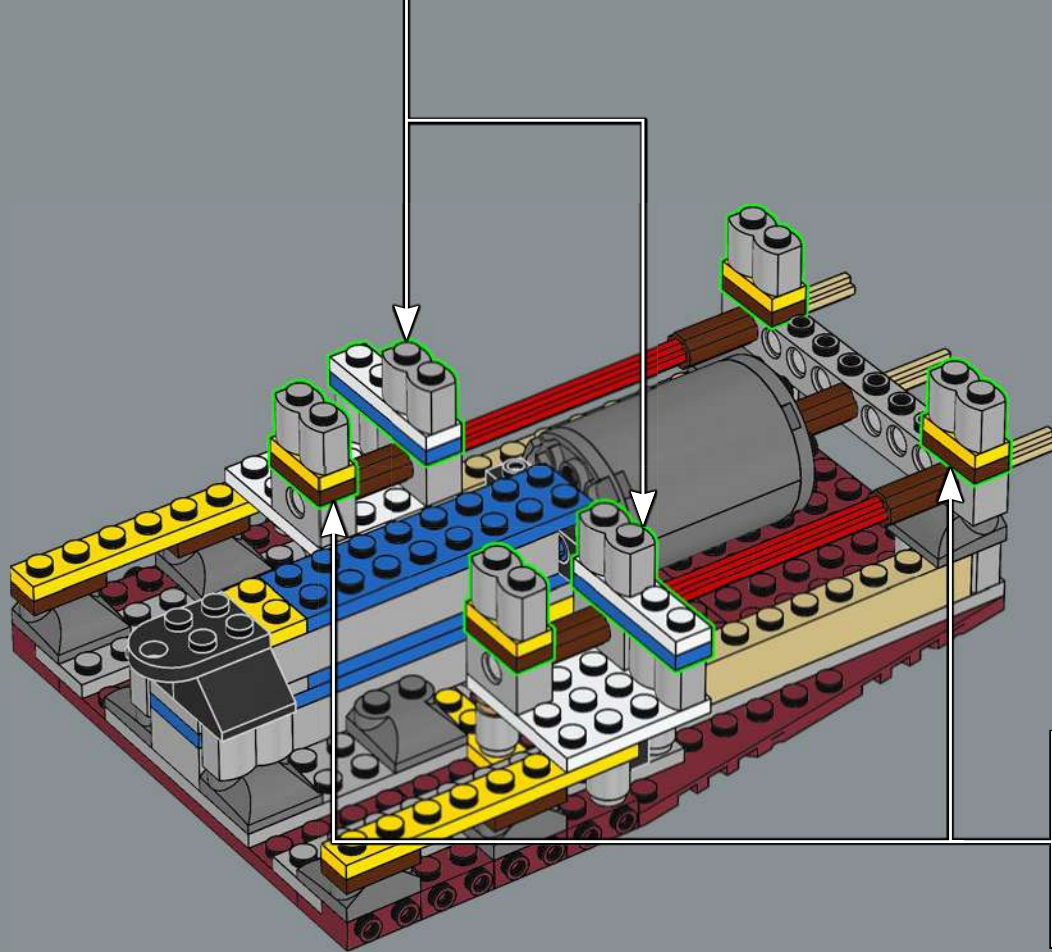
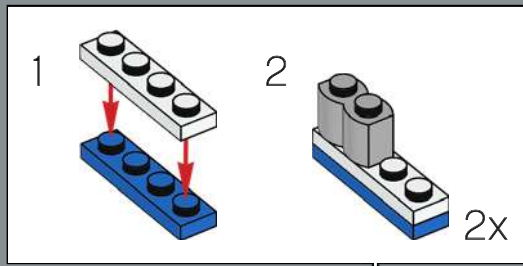

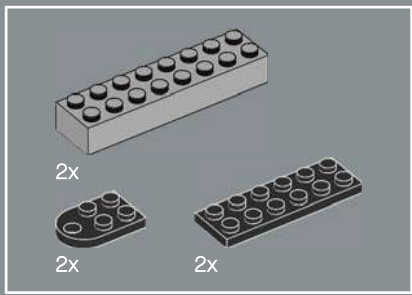

17

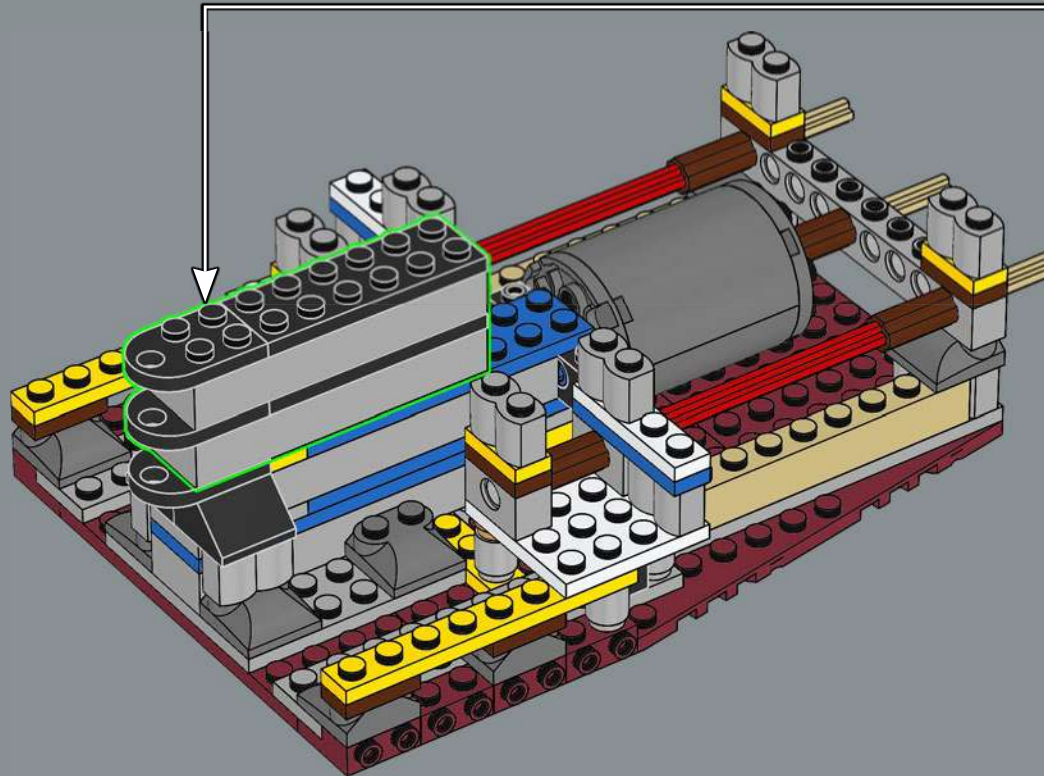
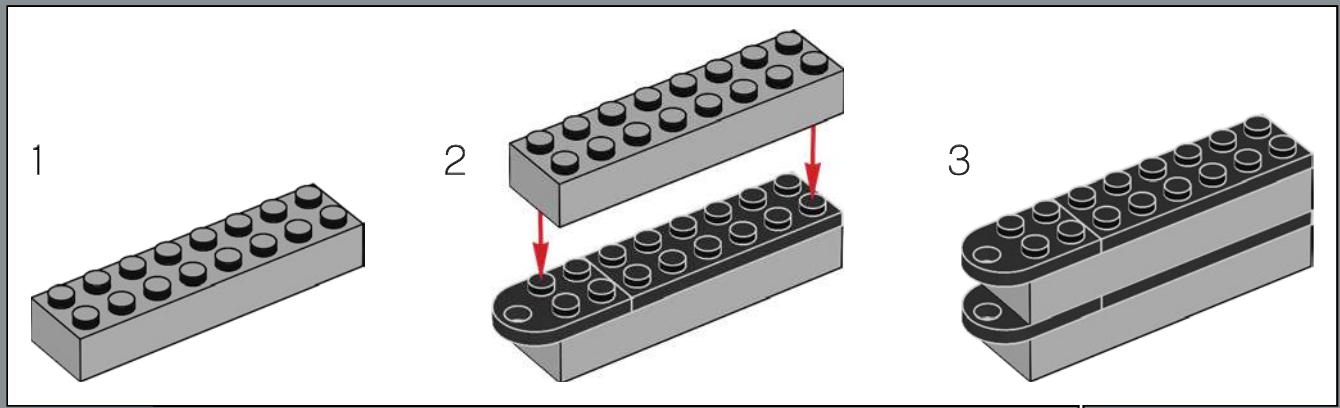

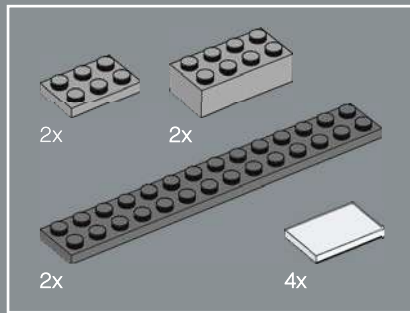

18

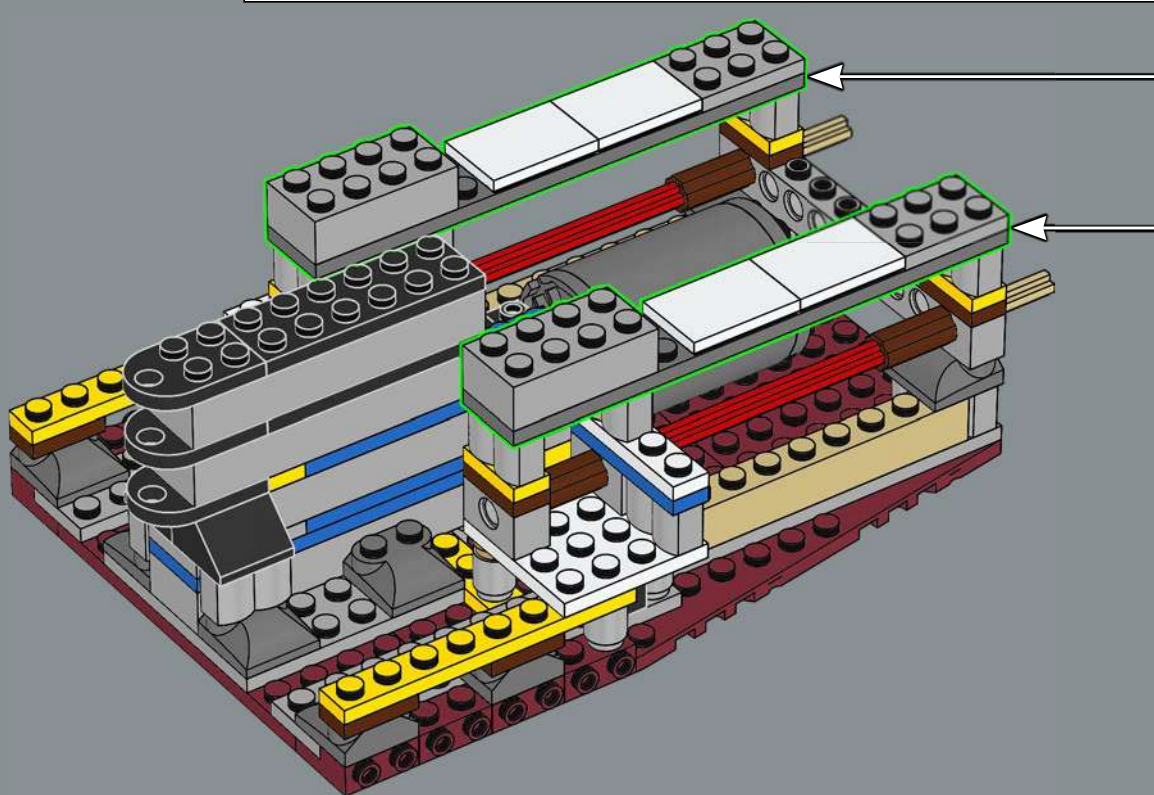
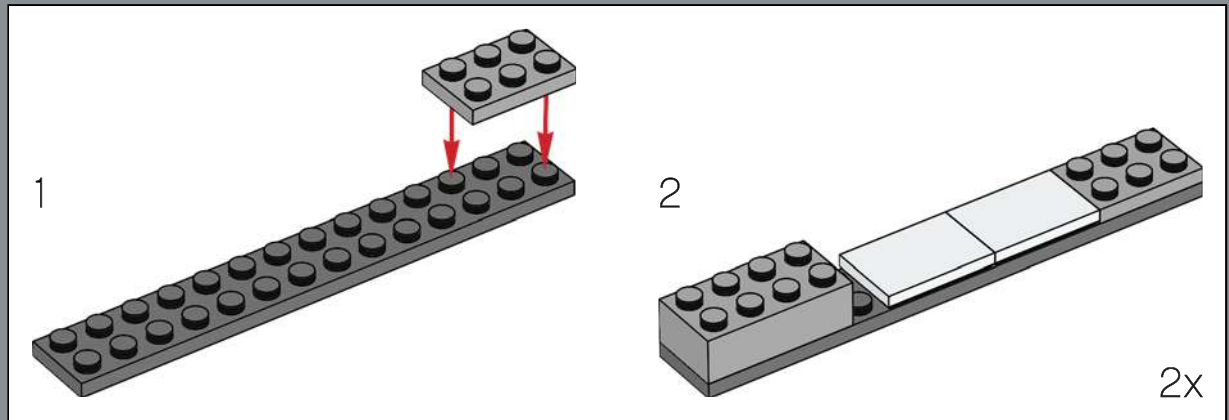



19

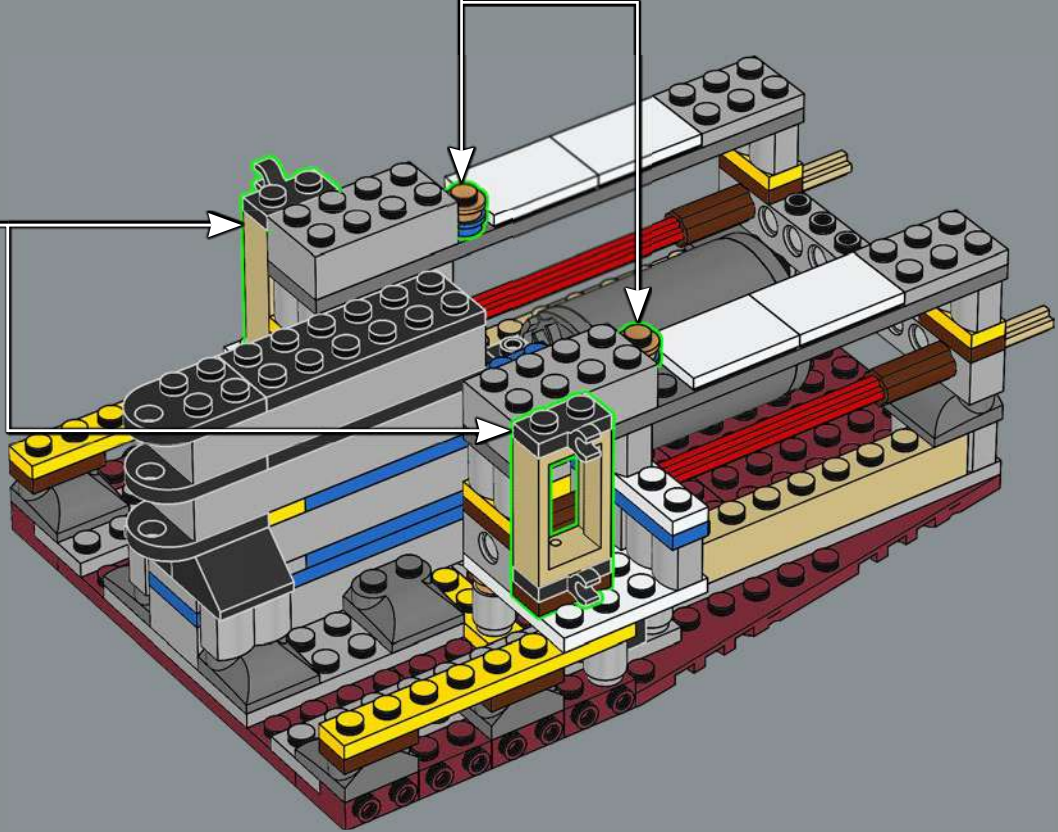
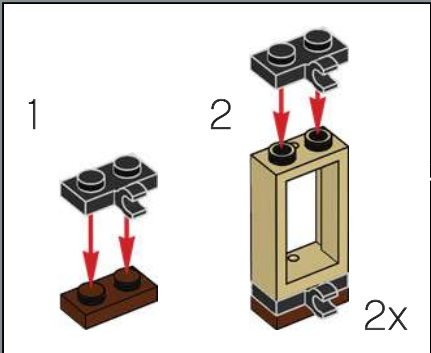
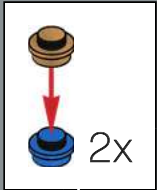

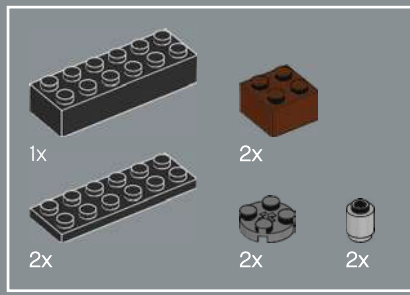

20

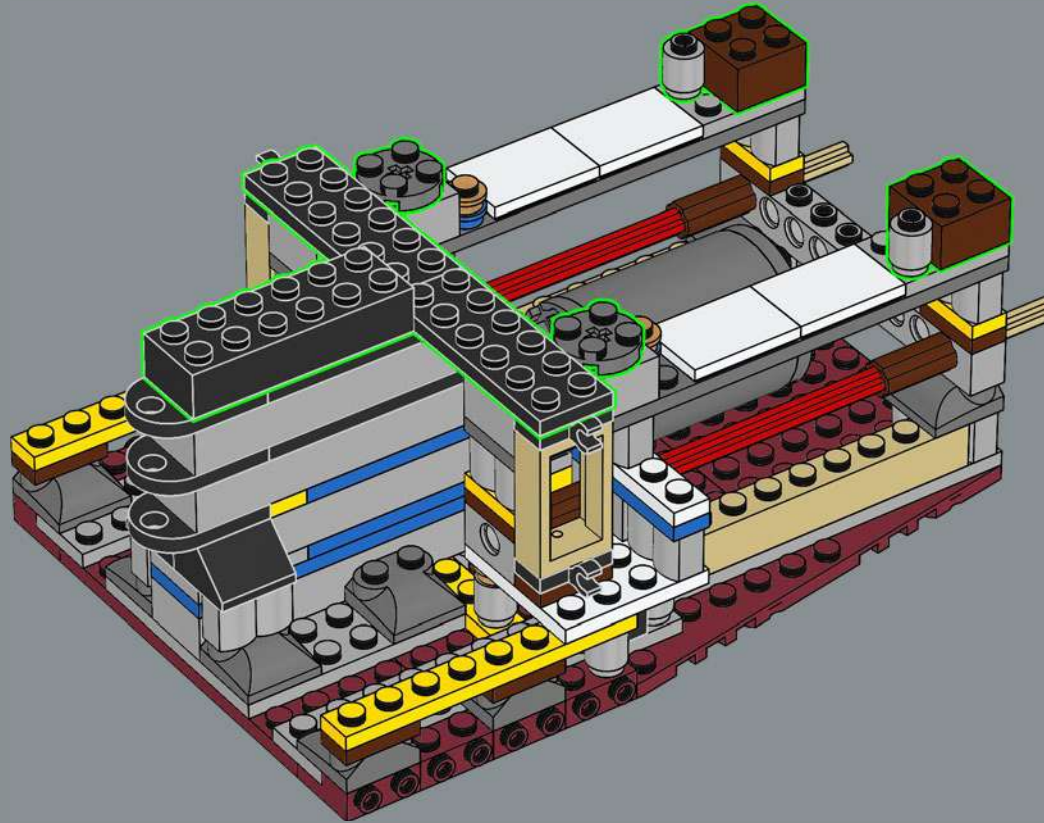

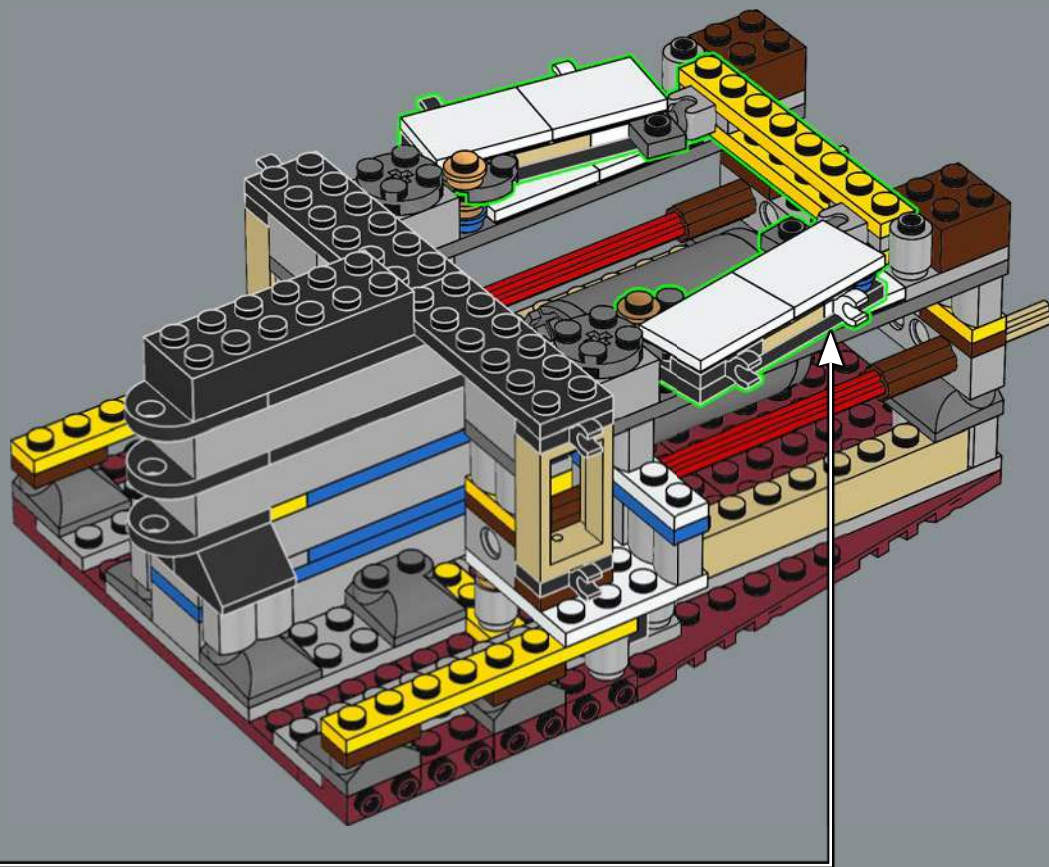

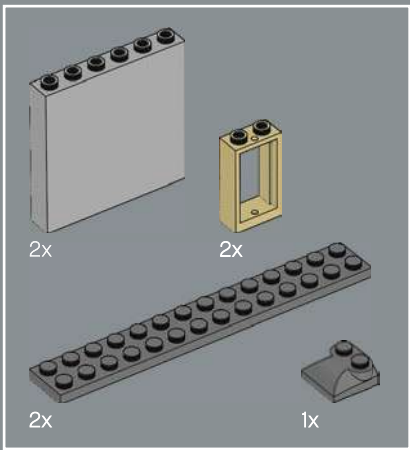

22

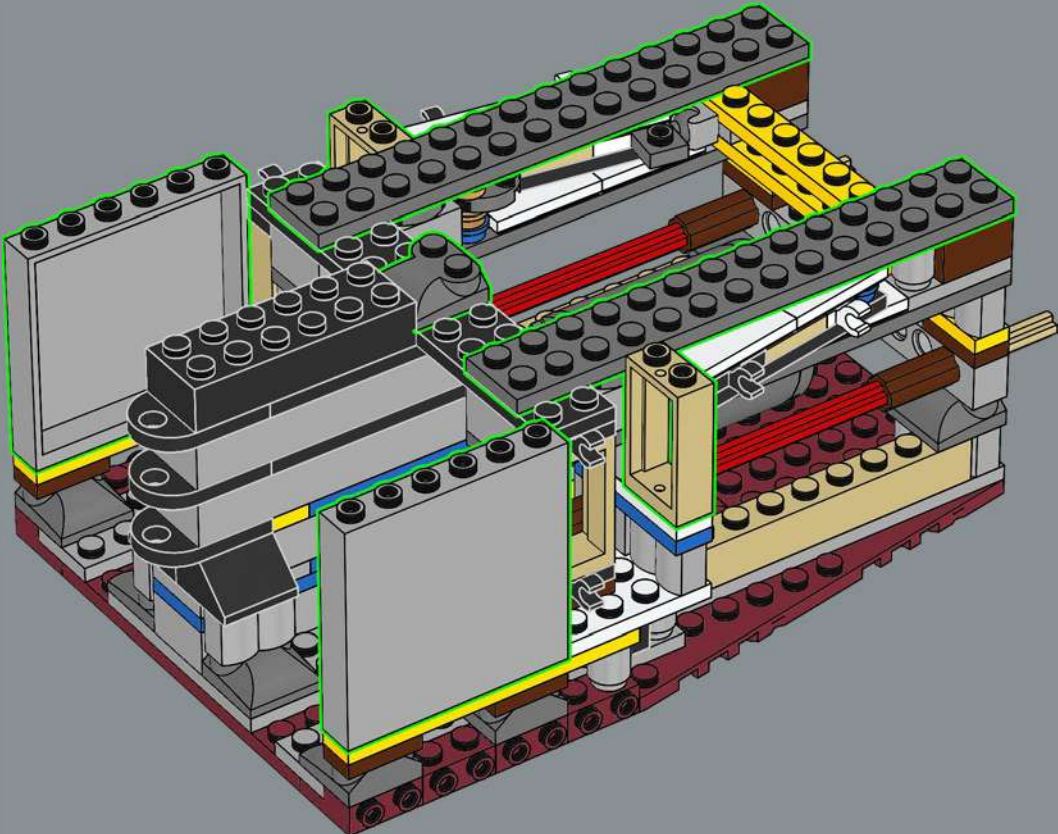

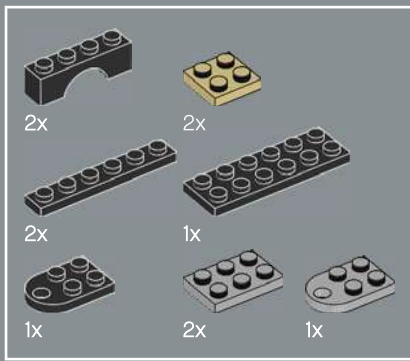

23

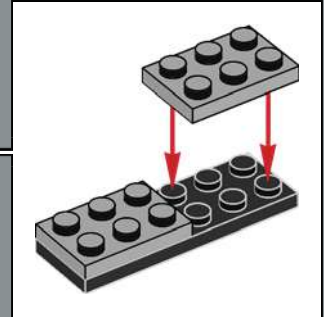
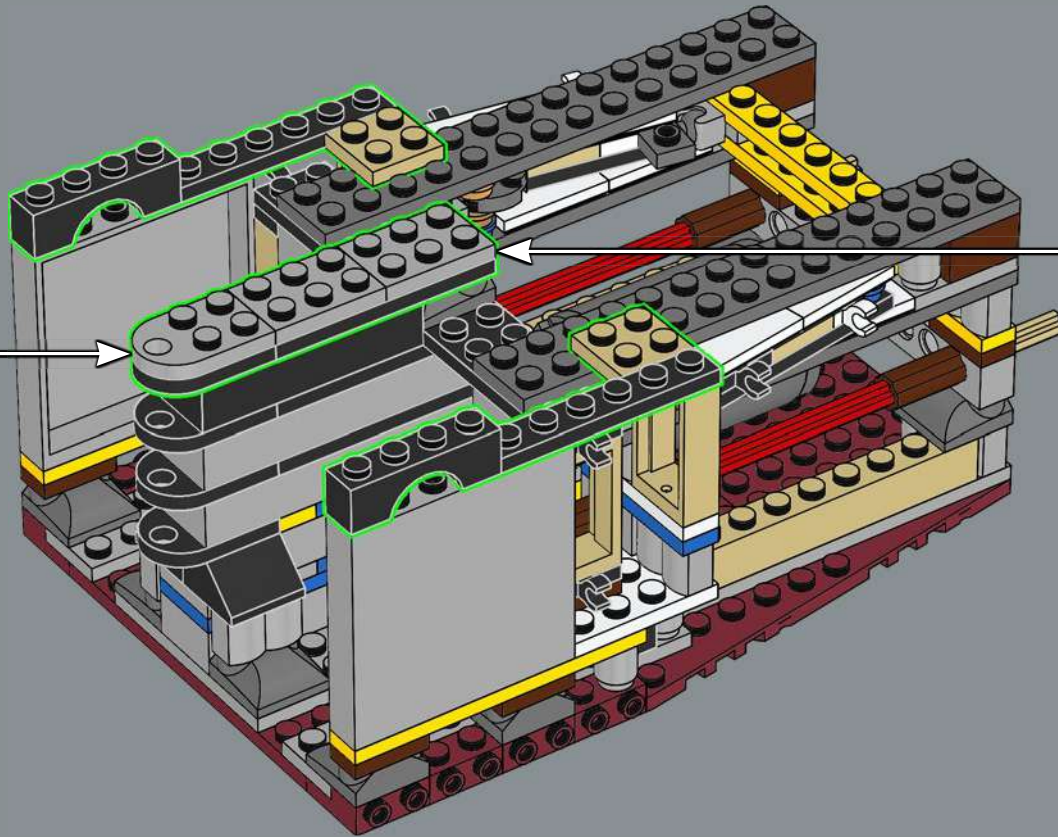
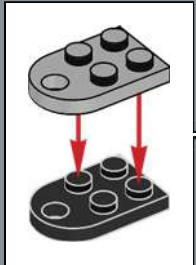

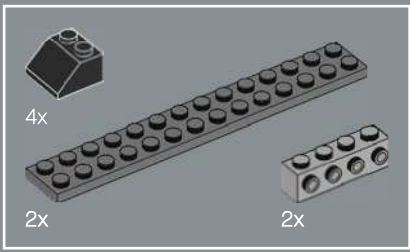

24

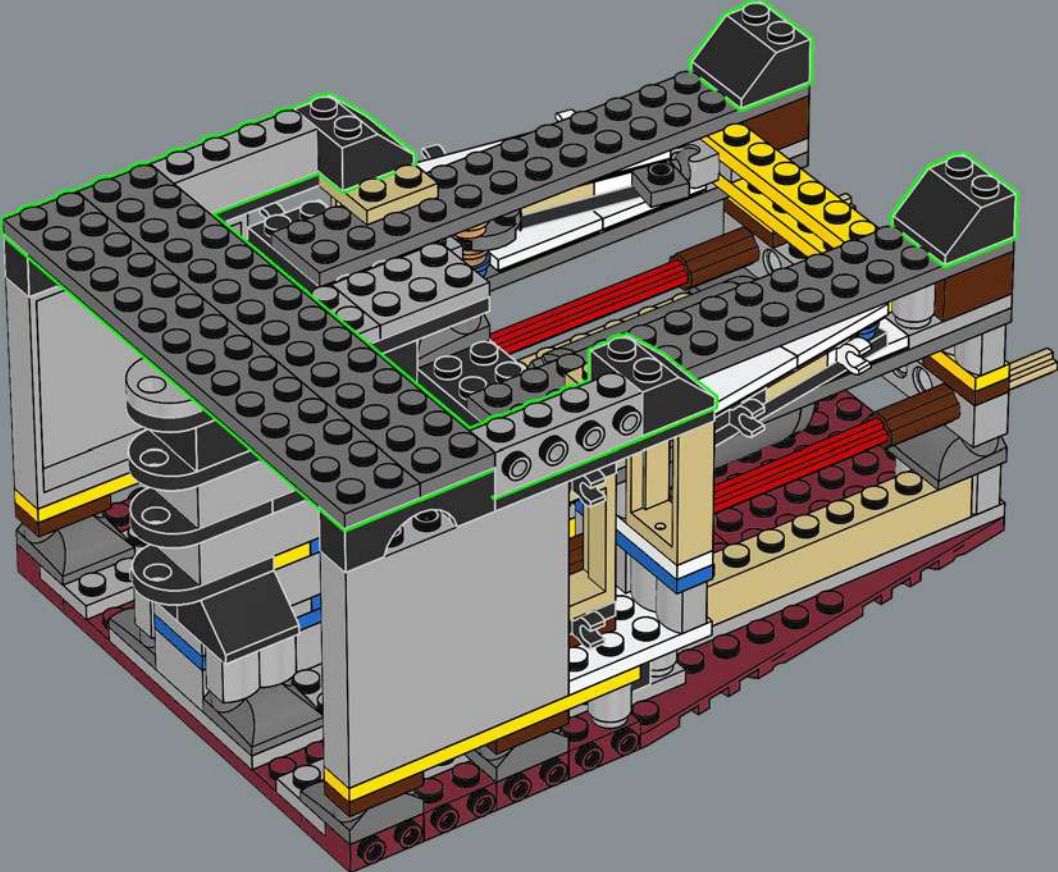

30

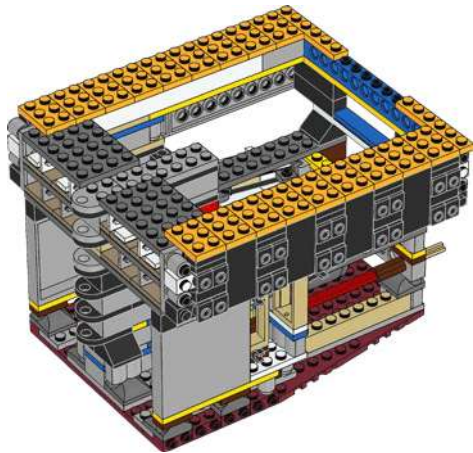
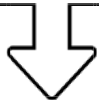

4x



1x



4x



2x



2x

25

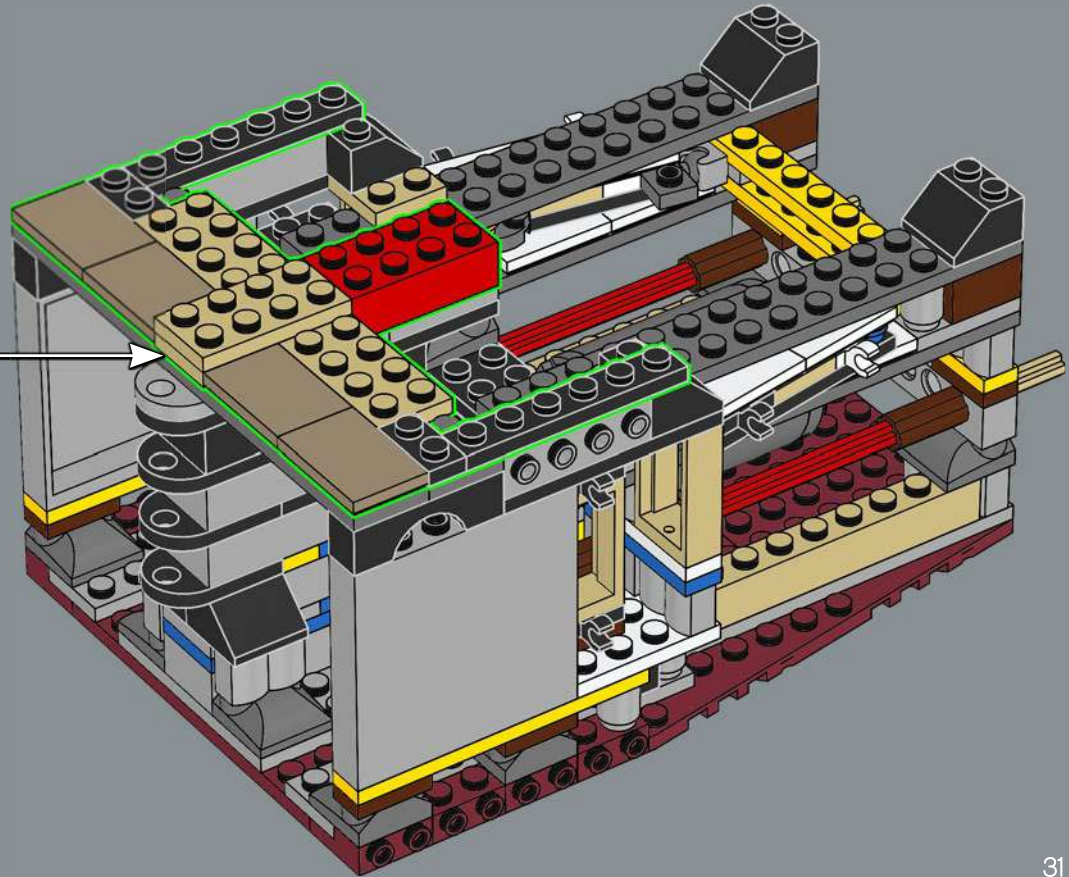
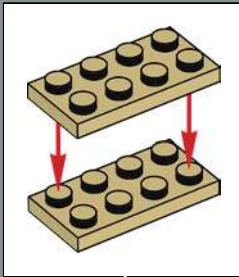

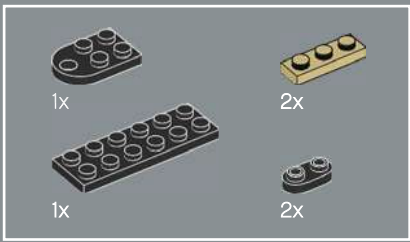

26

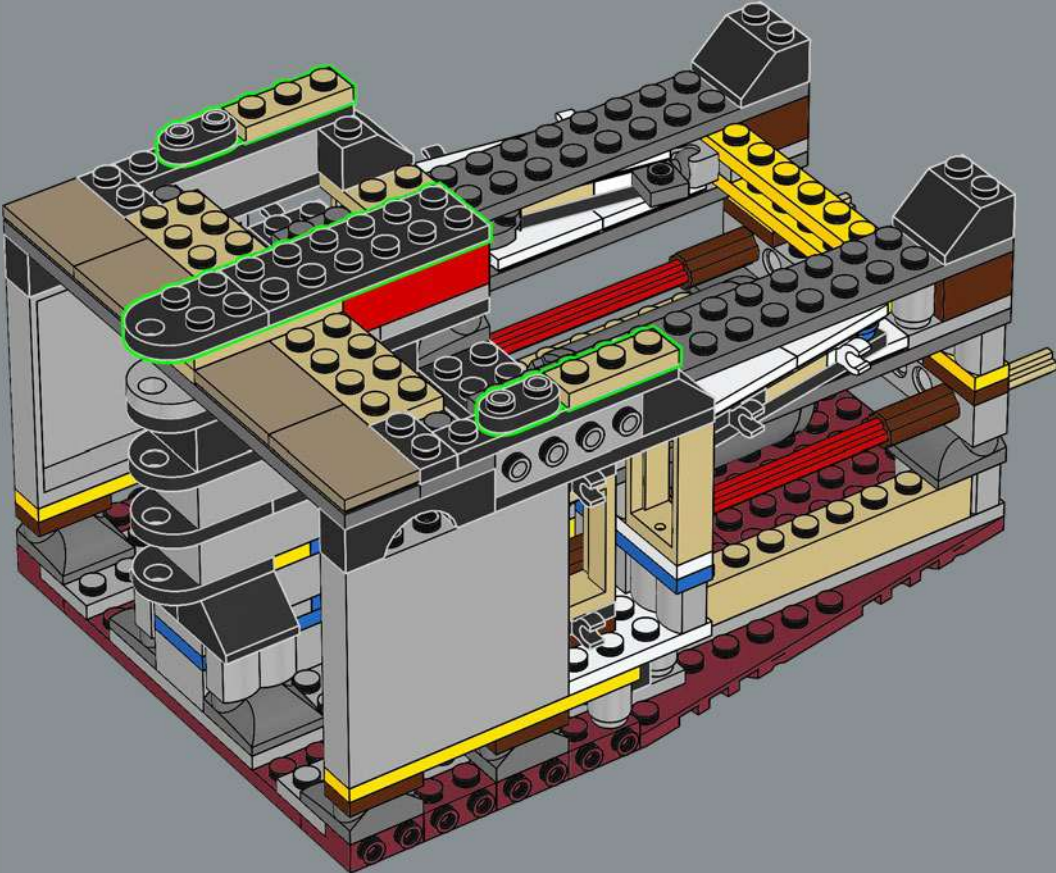

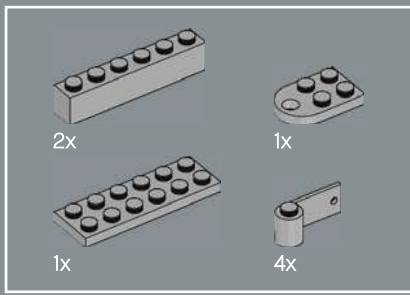

27

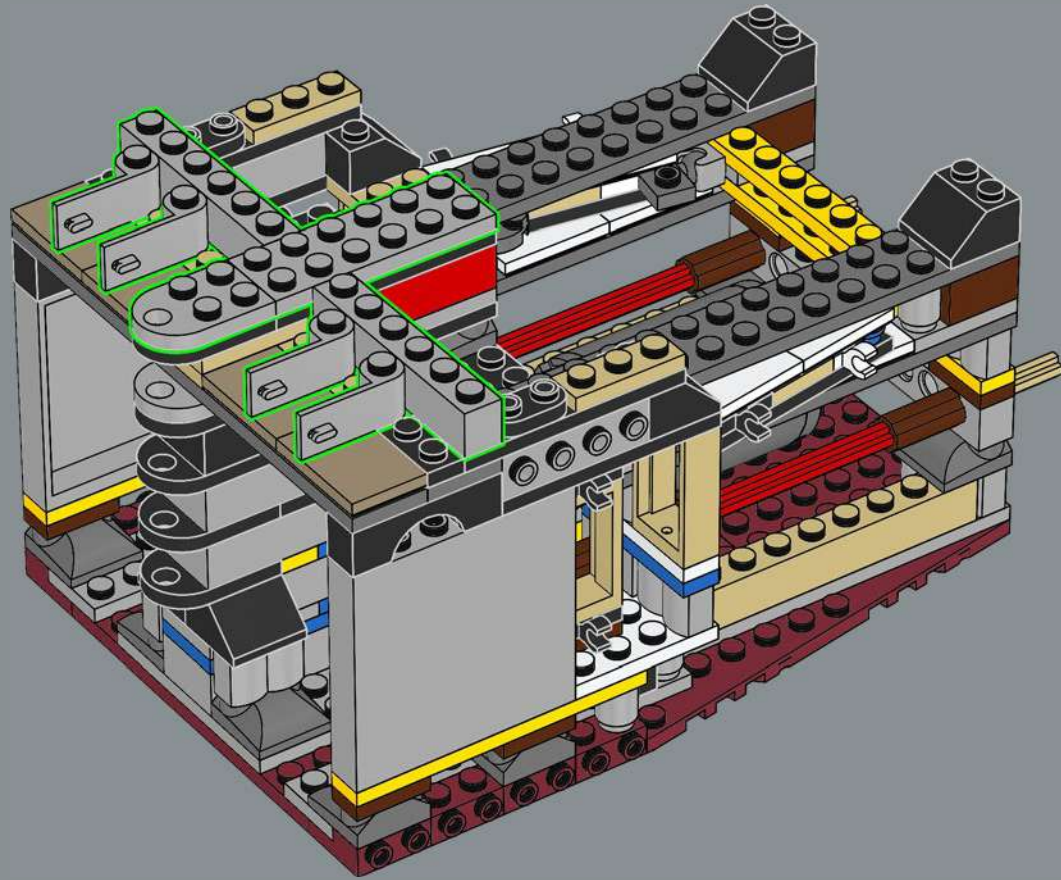

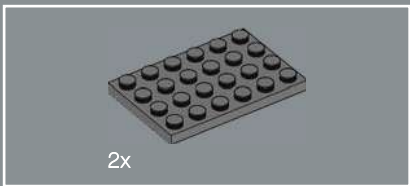

28

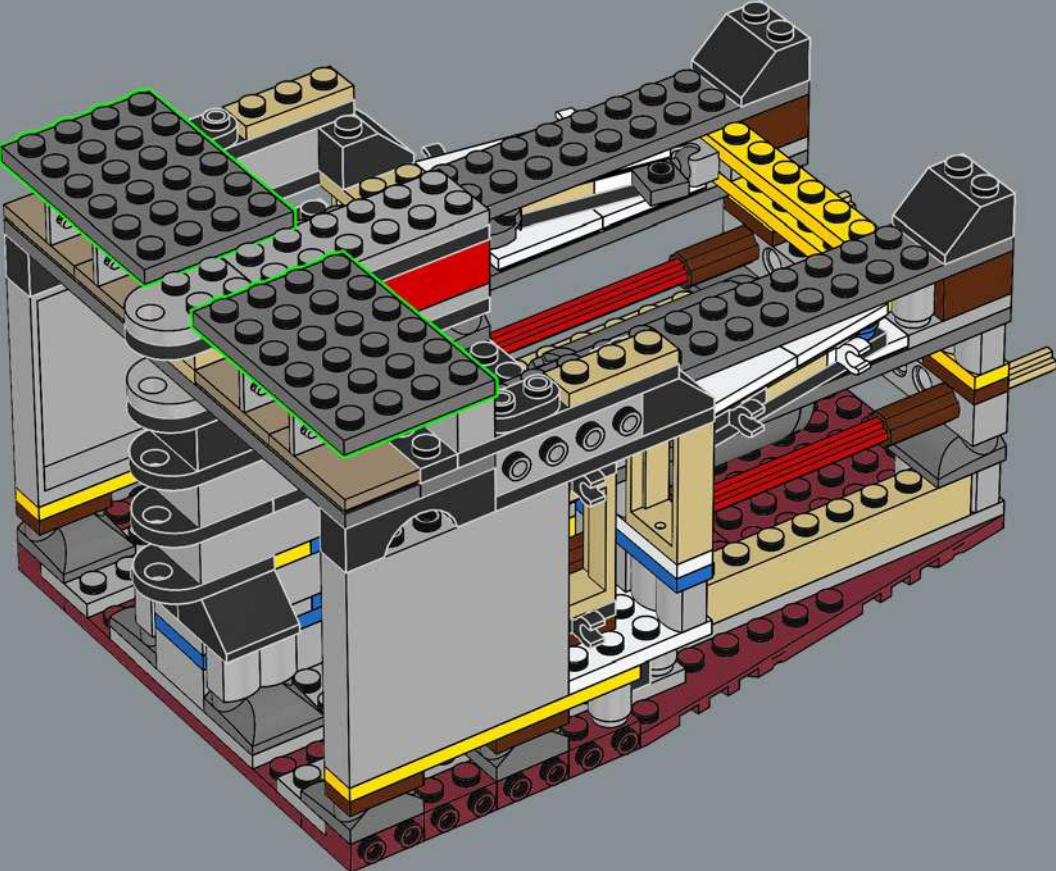

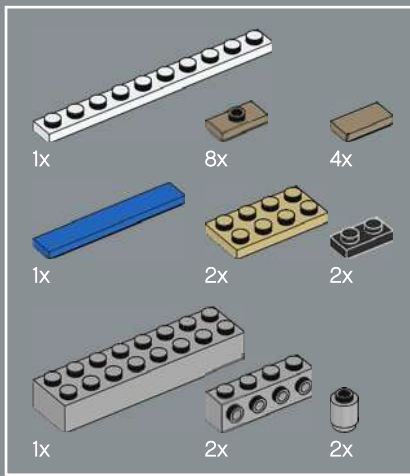

29

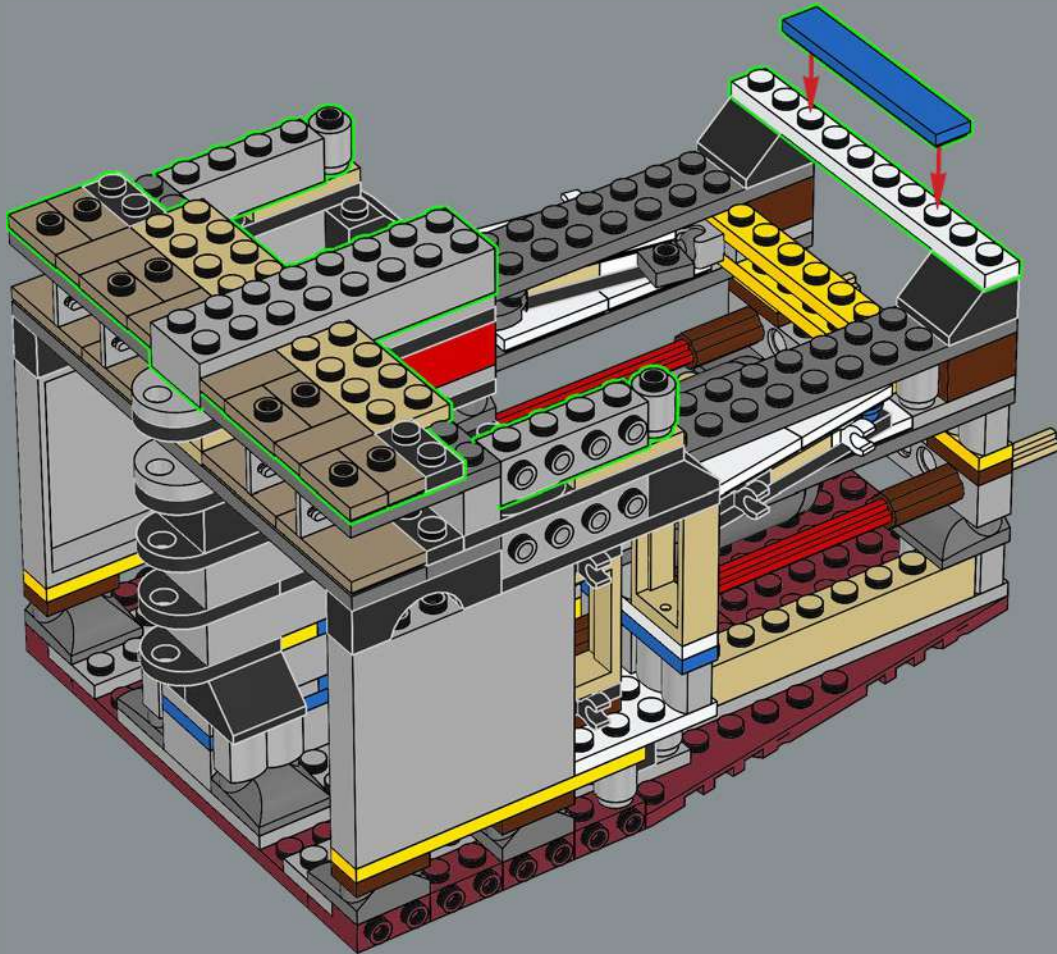

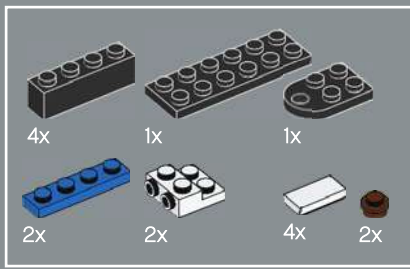

30

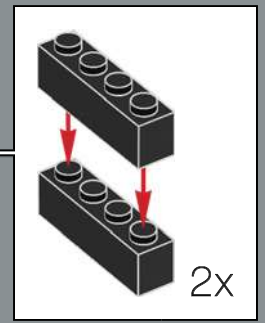
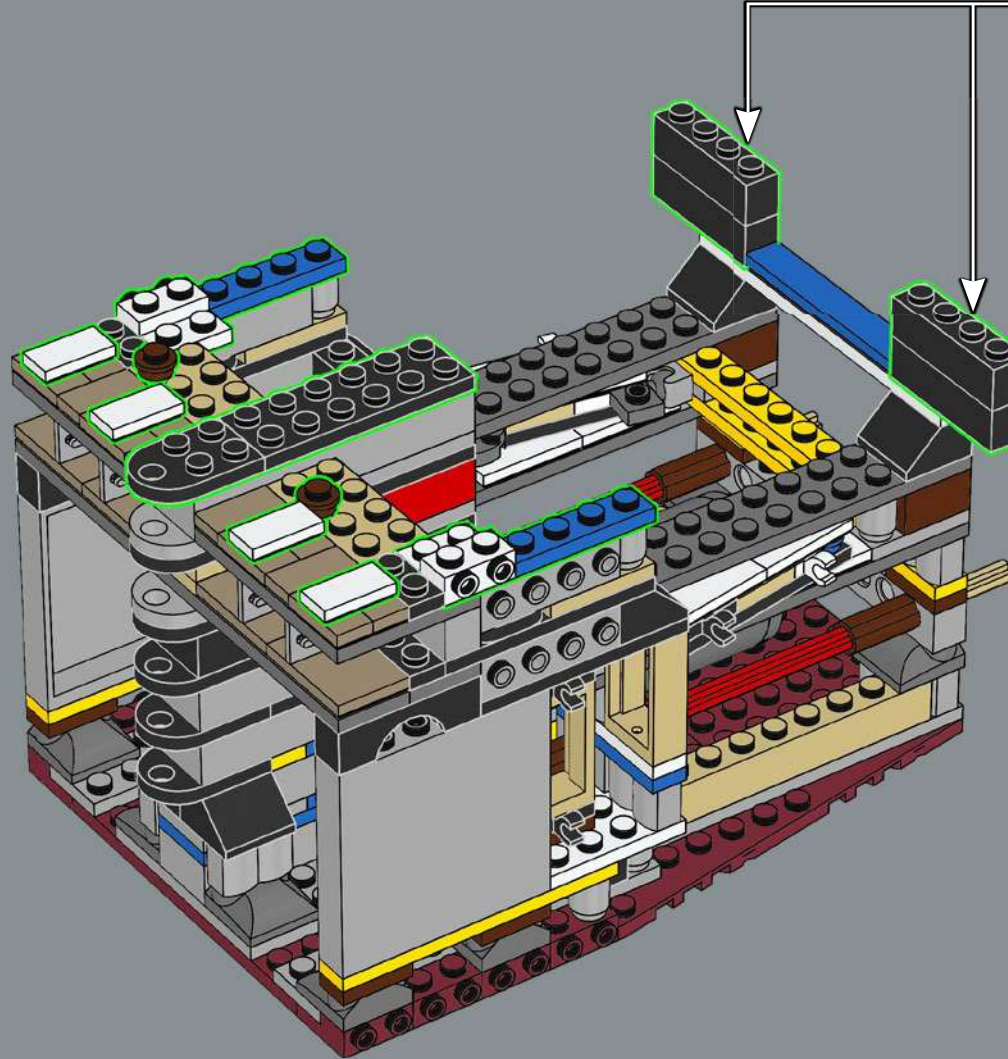

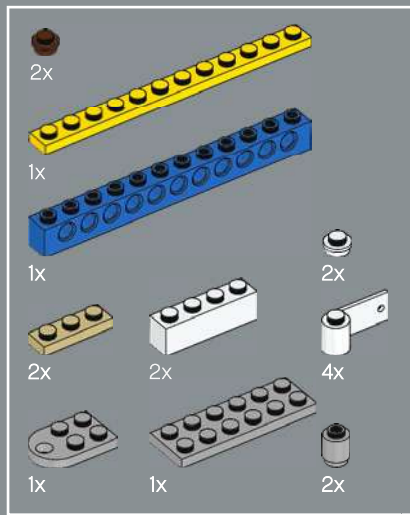

31

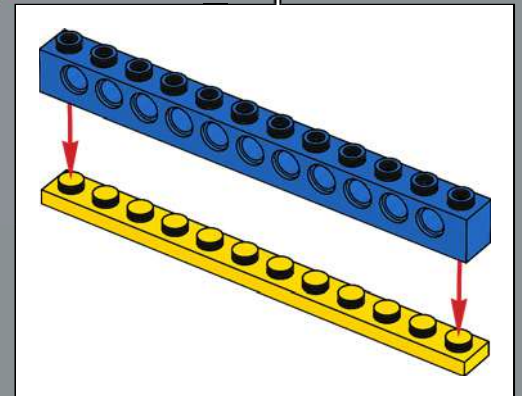
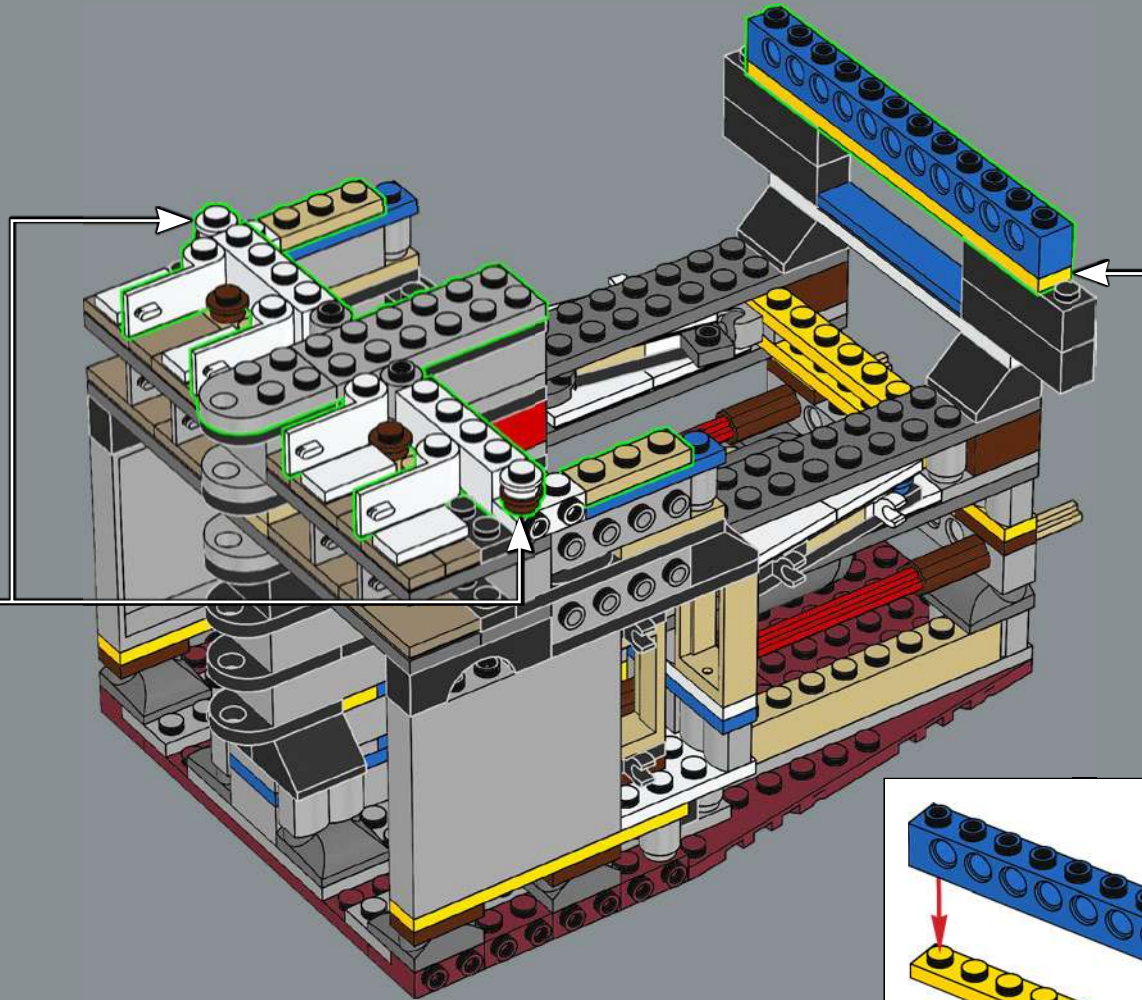
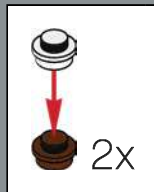

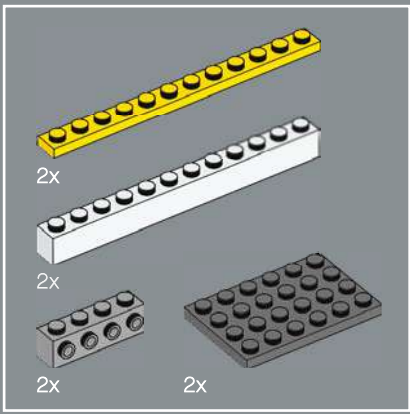

32

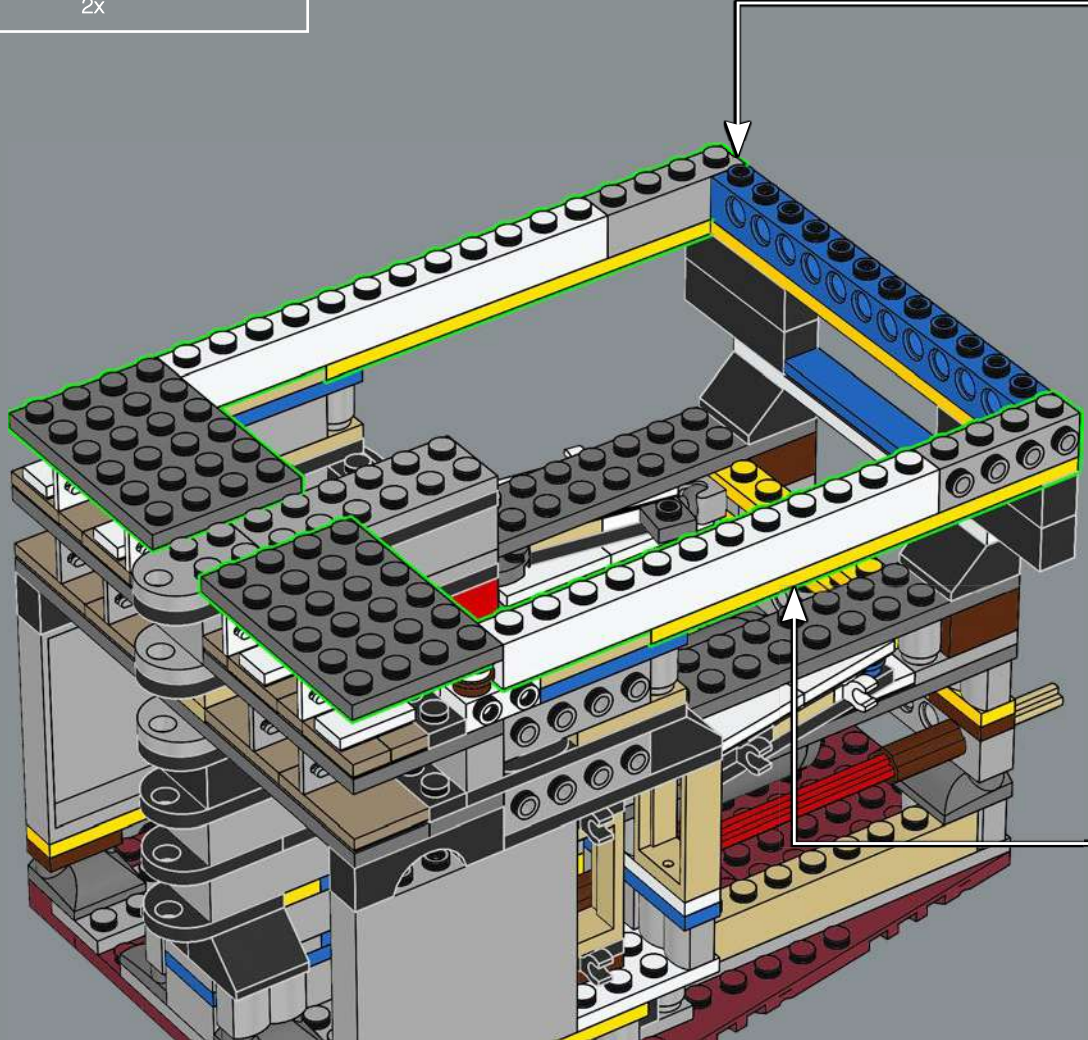
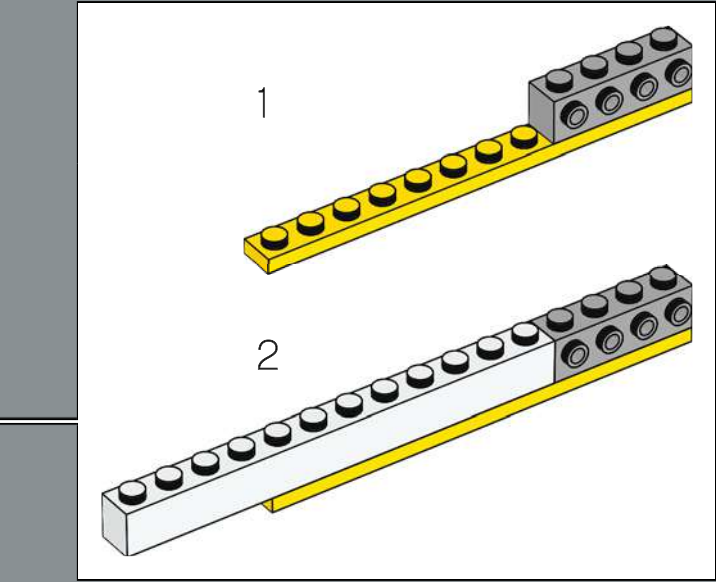
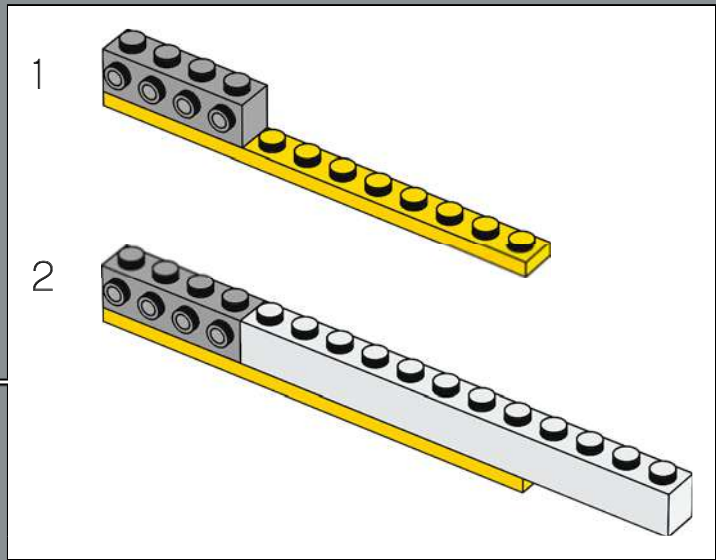

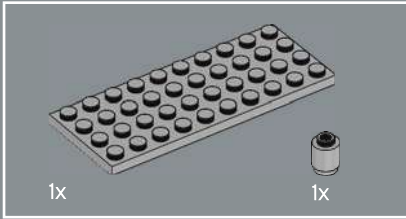
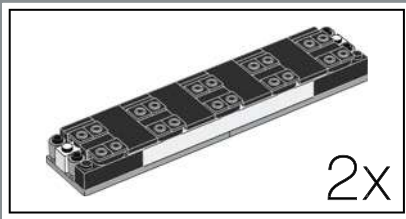

33

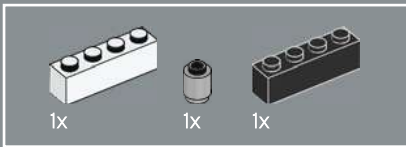
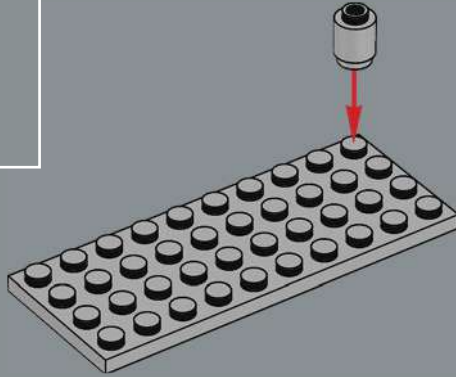

34

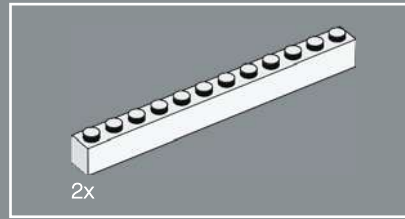
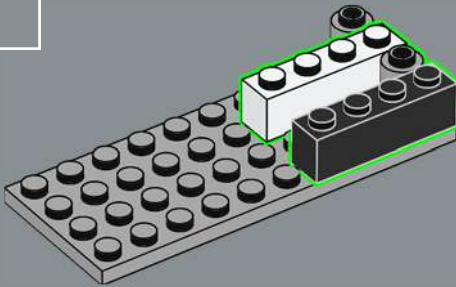

35

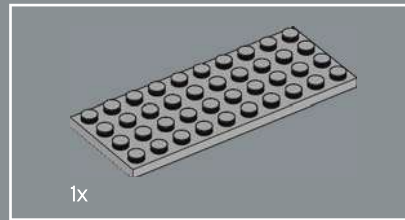
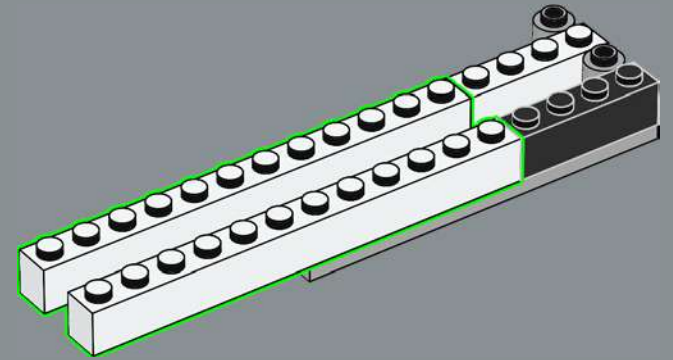

36

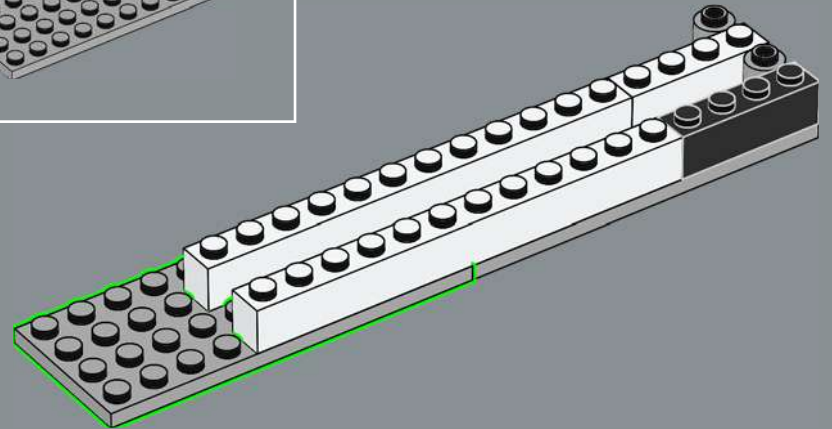

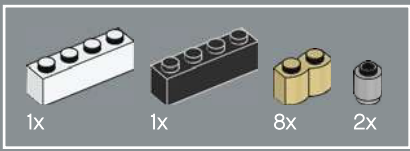

37

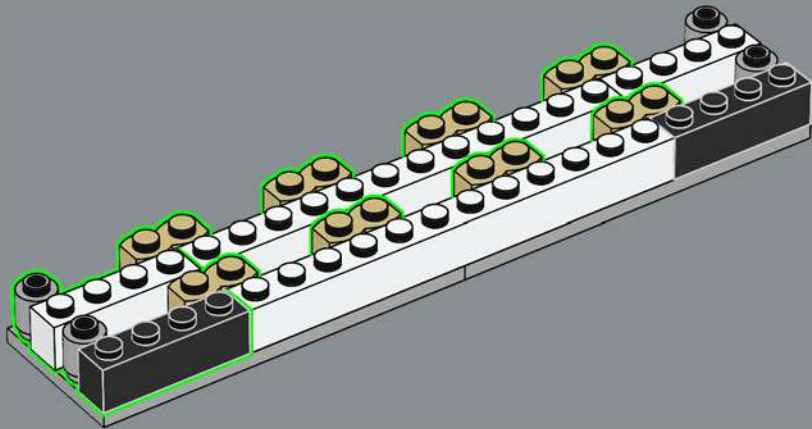

38

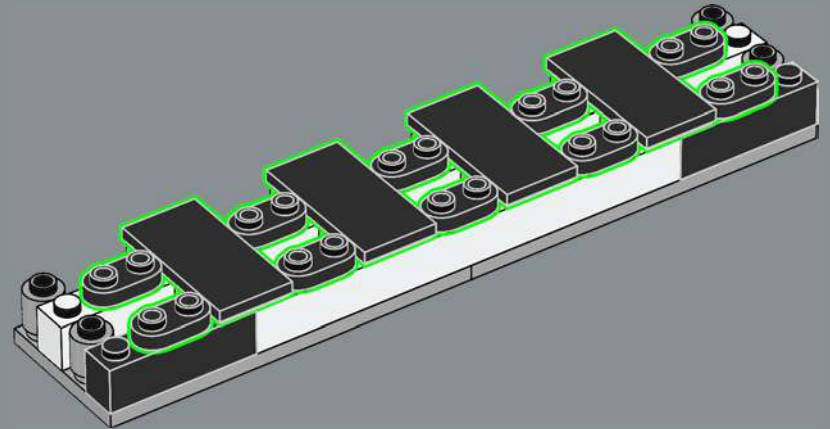



39

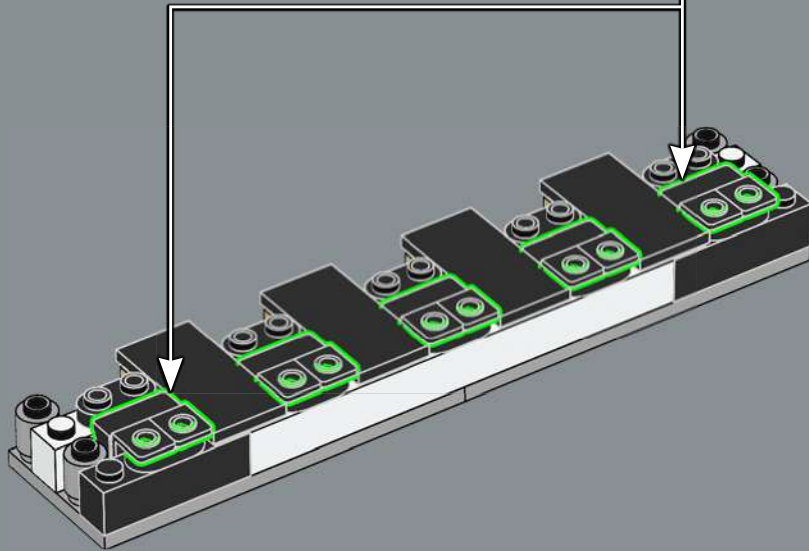
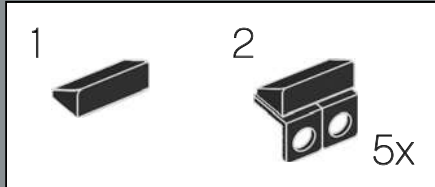

40

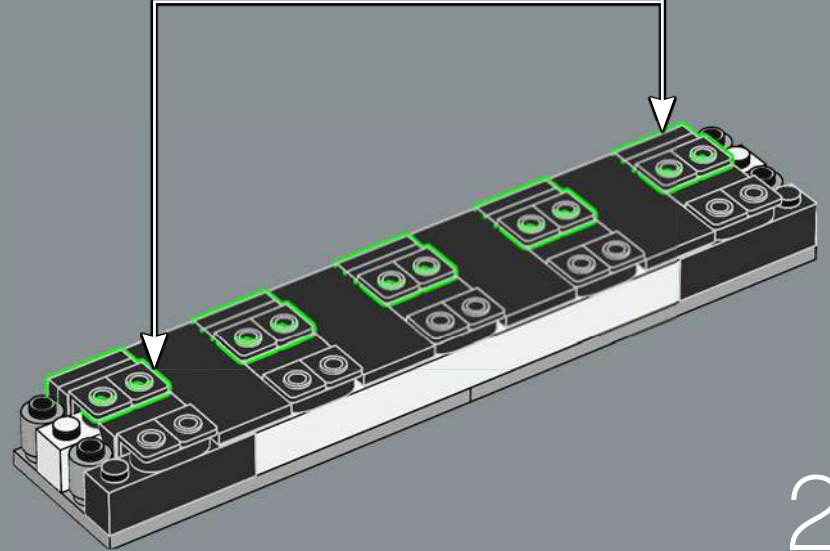
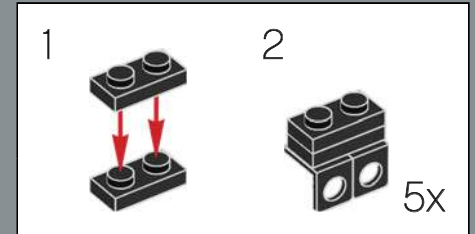

2x

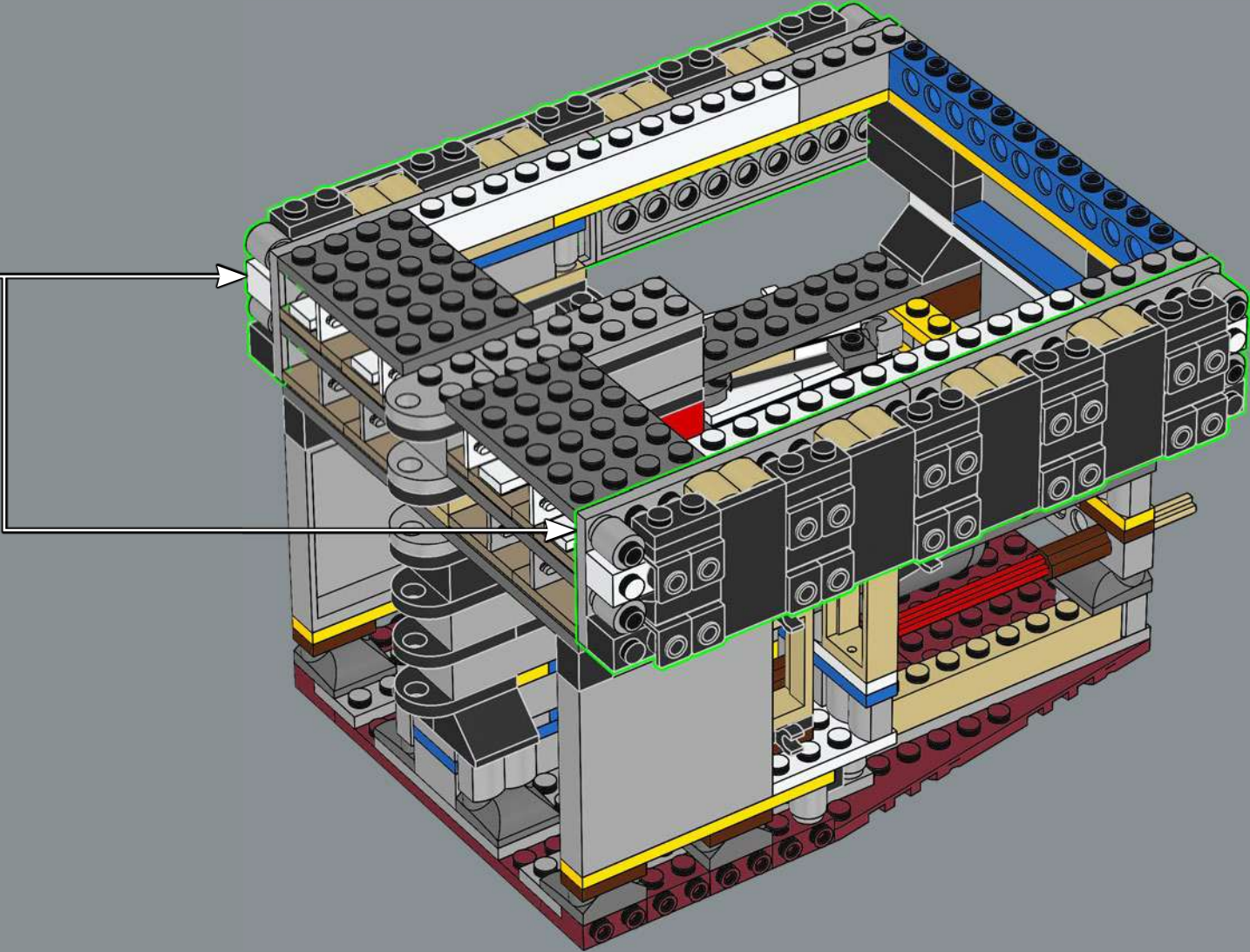

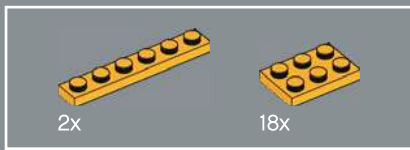

42

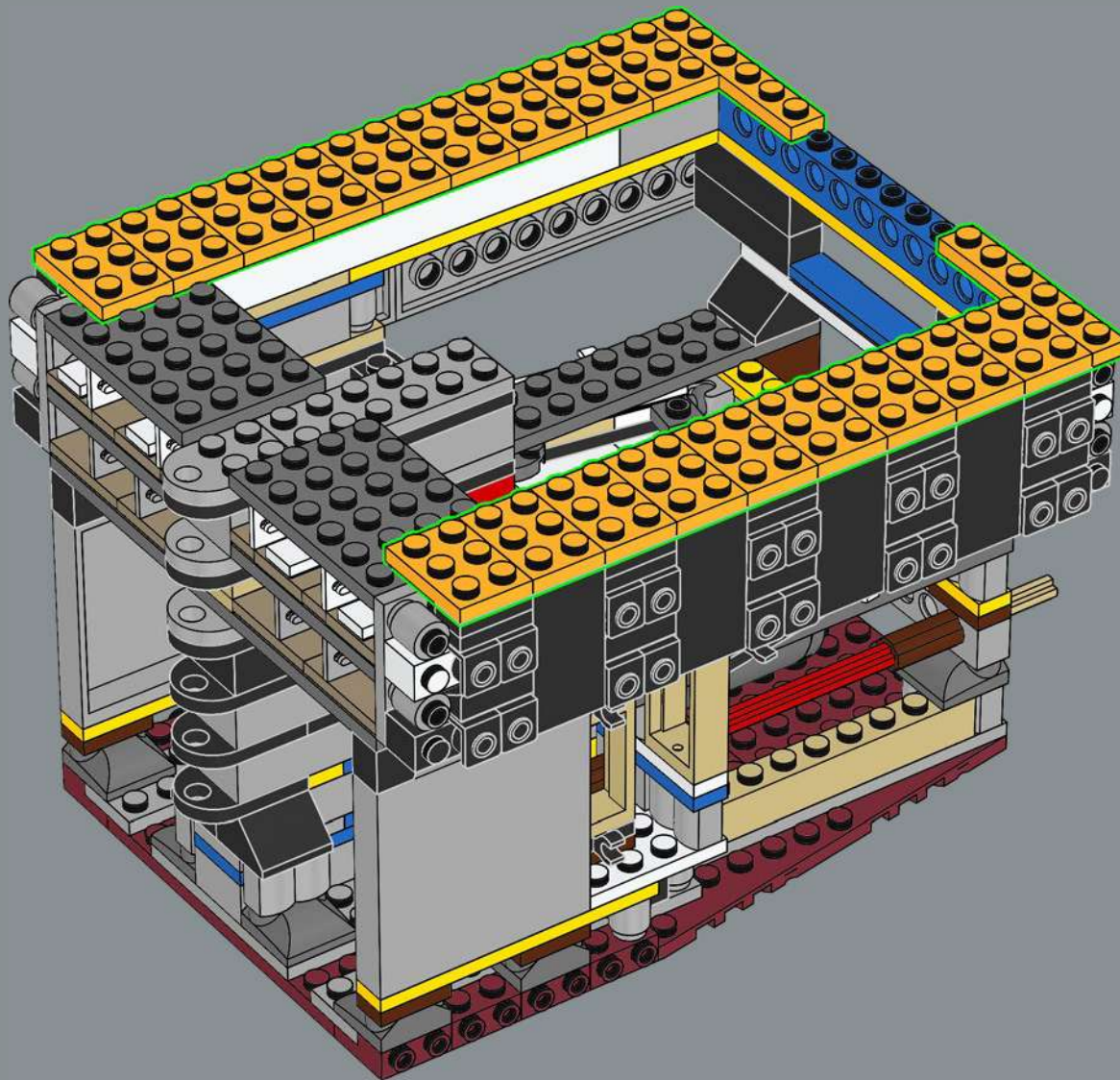

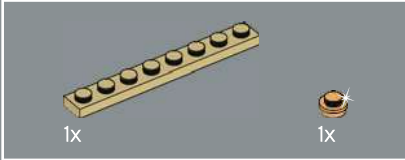
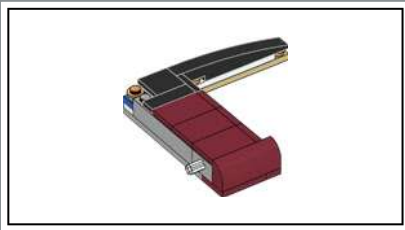
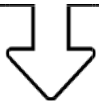

43

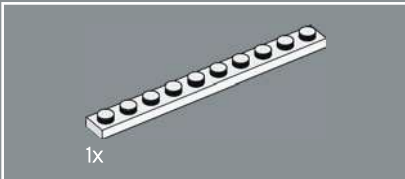
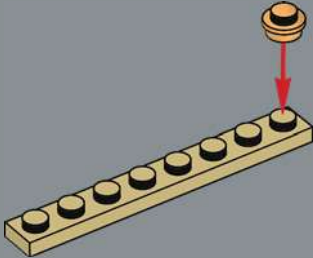

44

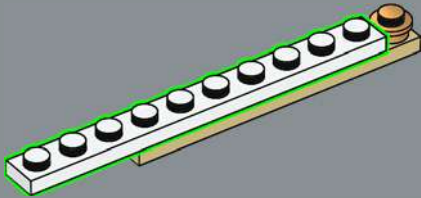

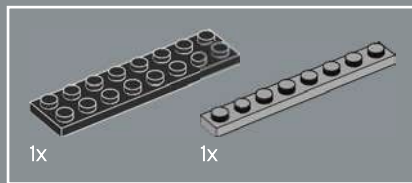

45

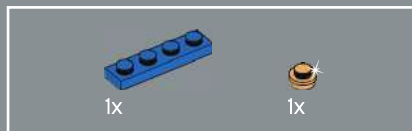
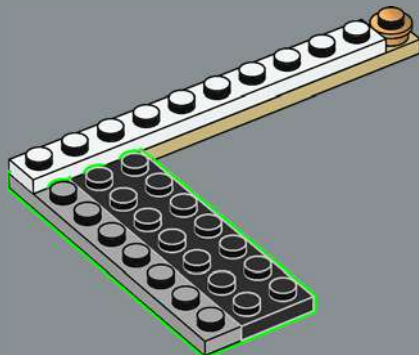

46

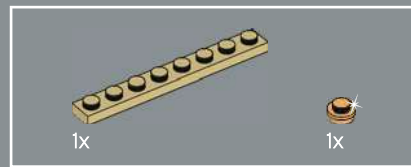
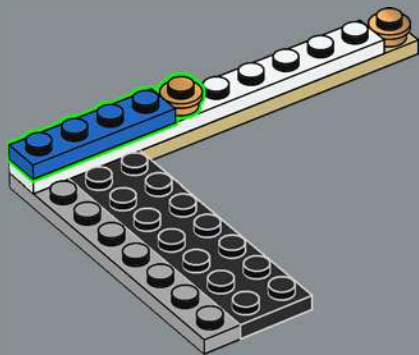

47

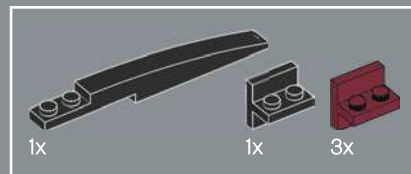
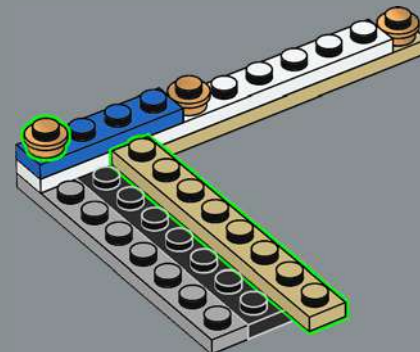

48

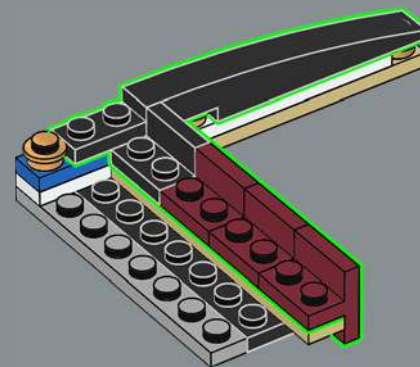

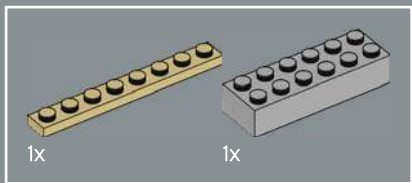

49

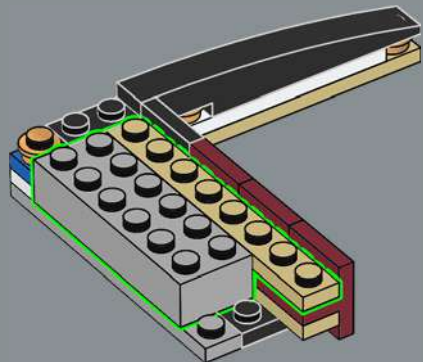

50

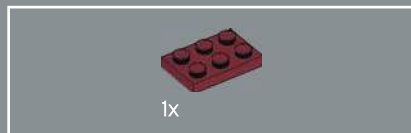
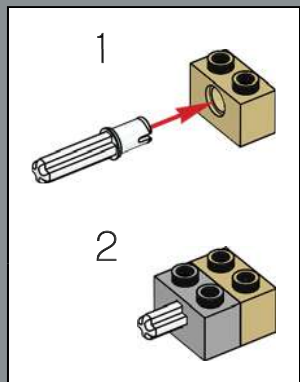
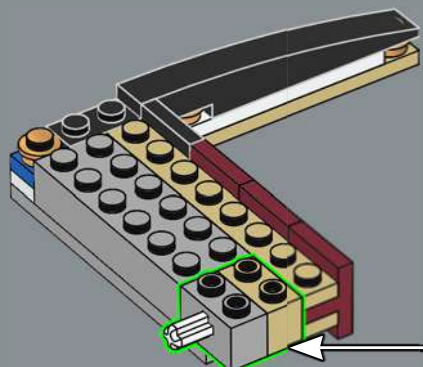

51

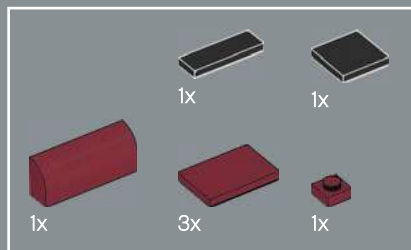
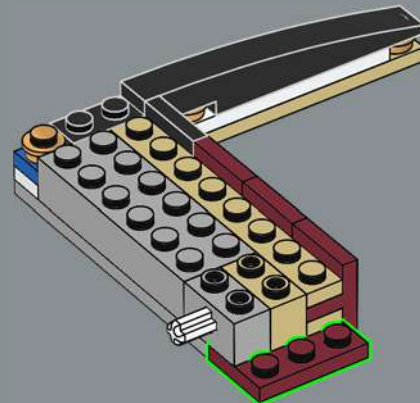

52

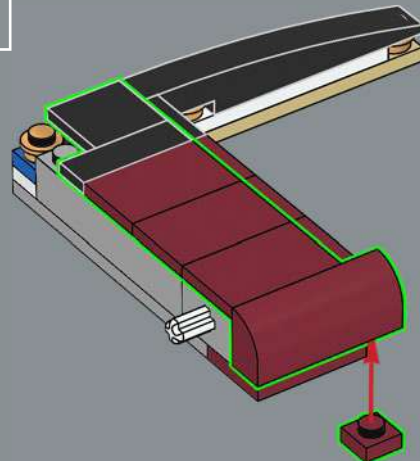

53

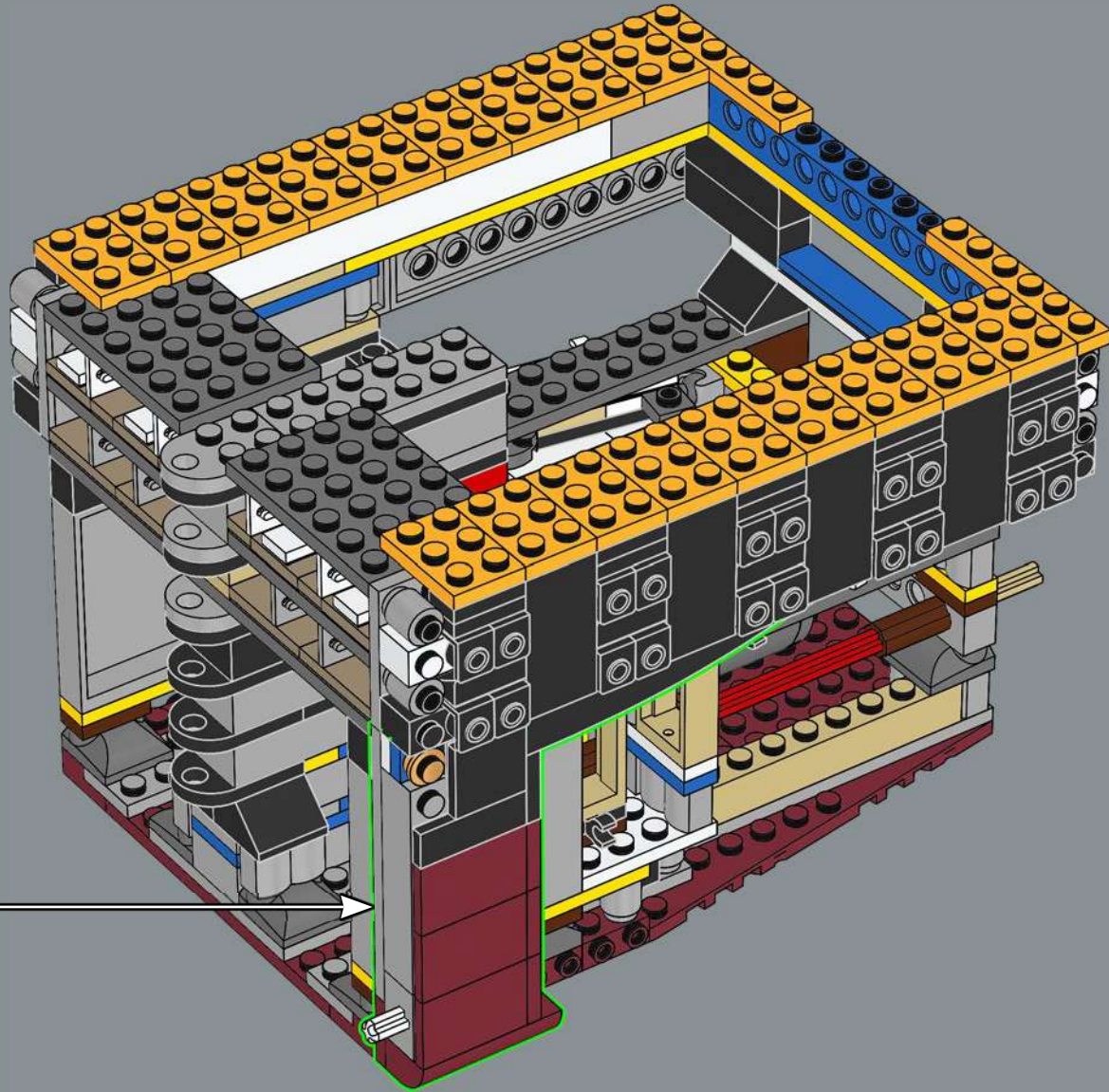

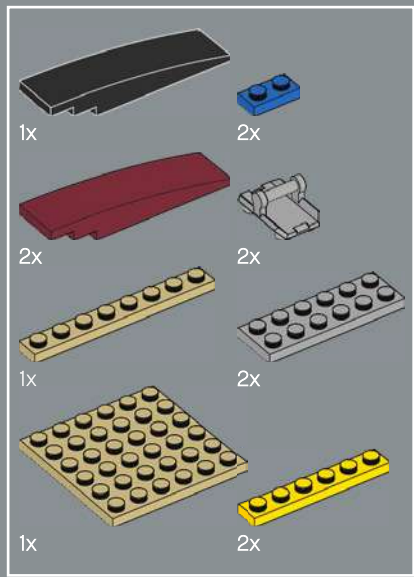

54

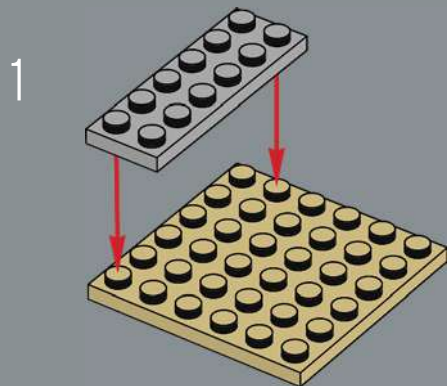

2

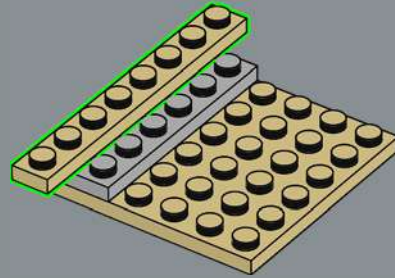

3

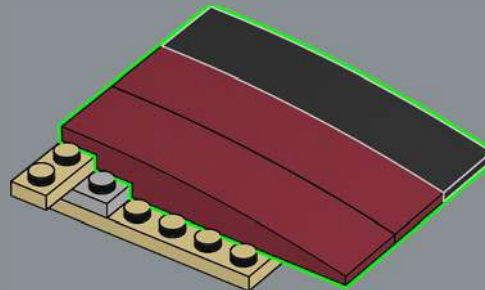

4

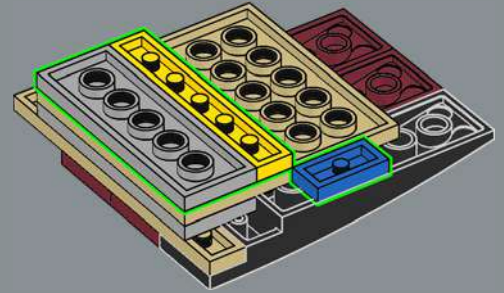

5

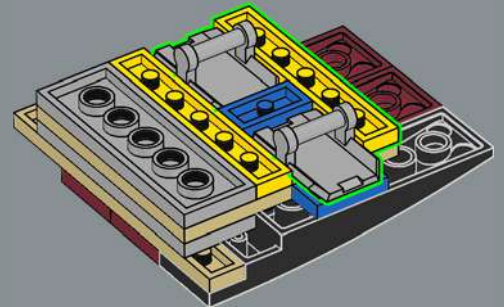

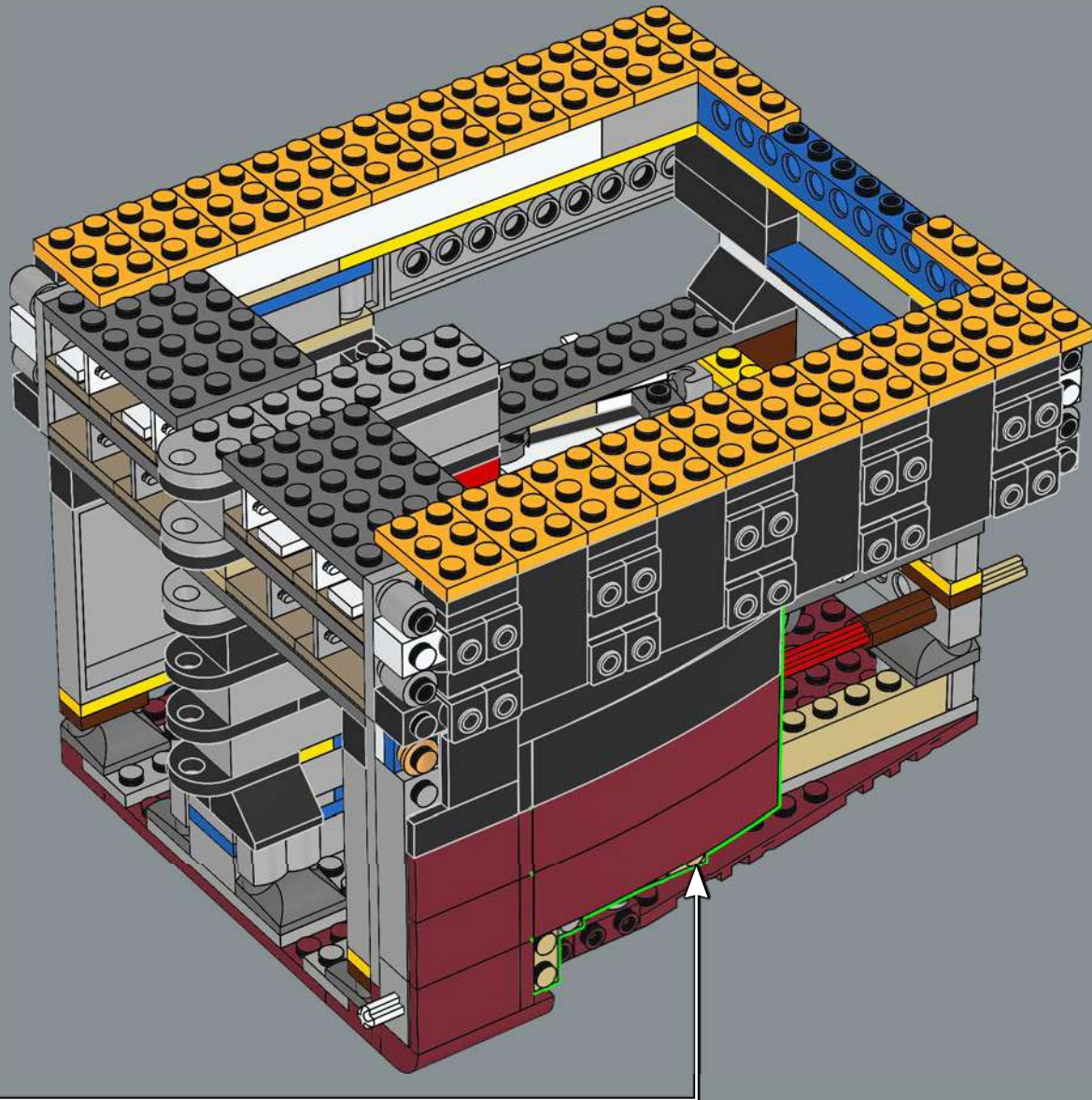

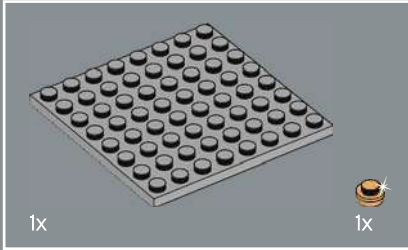
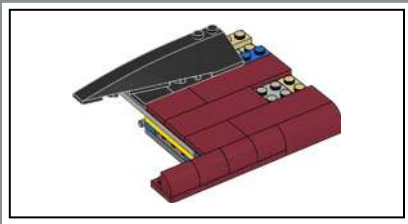

55

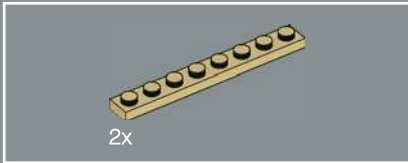
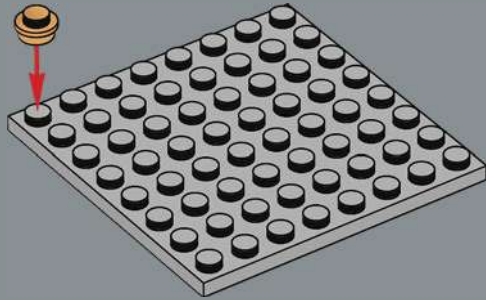

56

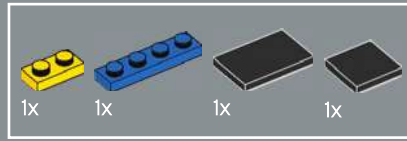
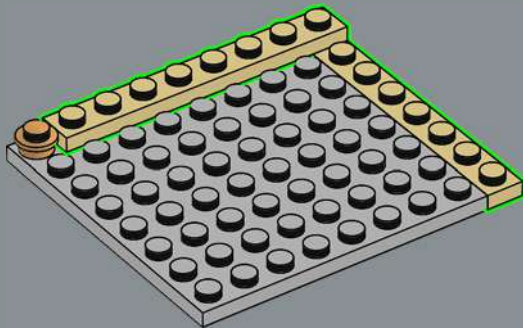

57

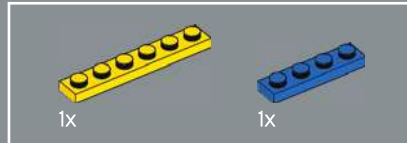
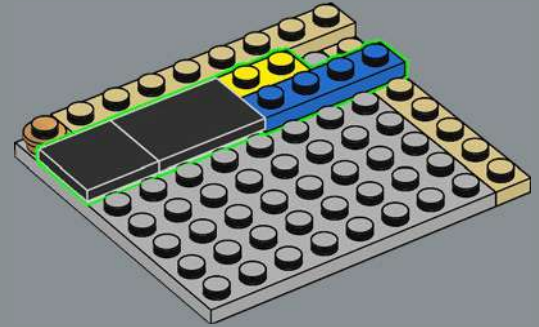

58

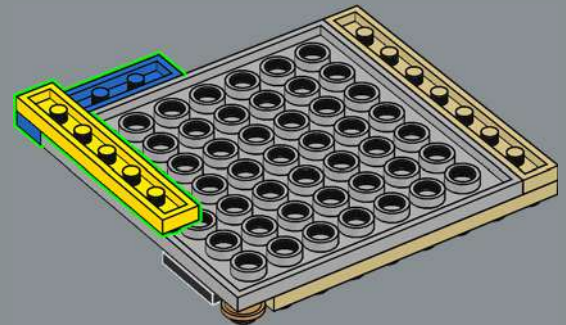

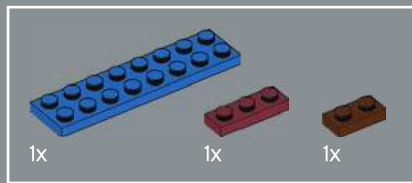

59

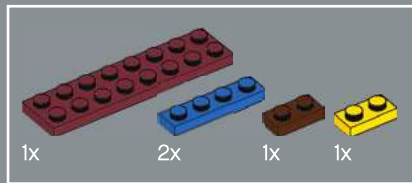
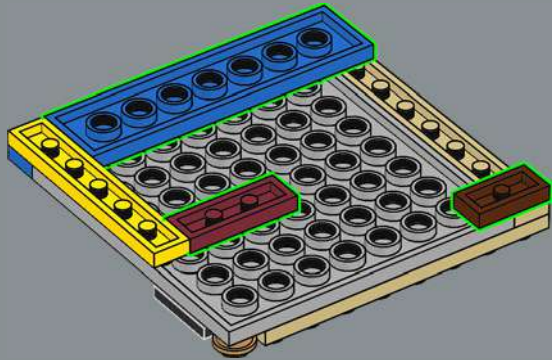

60

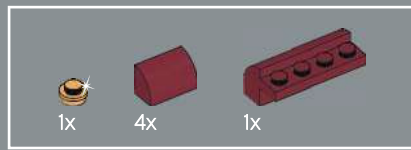
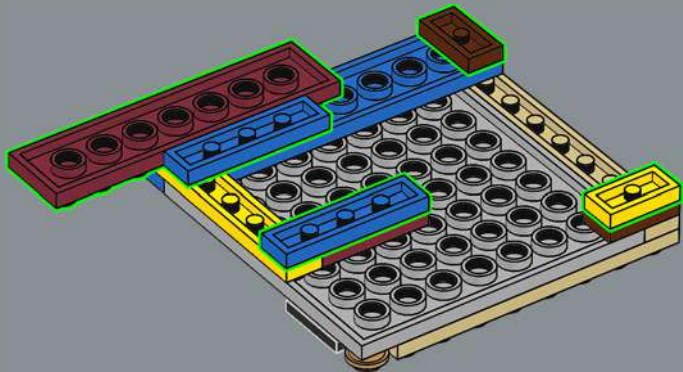

61

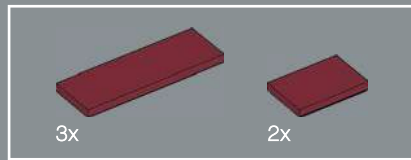
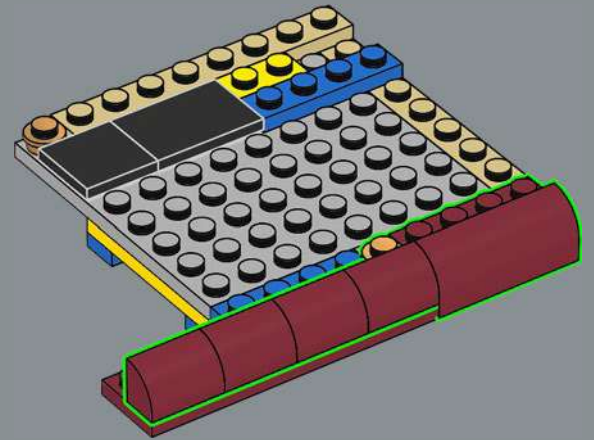

62

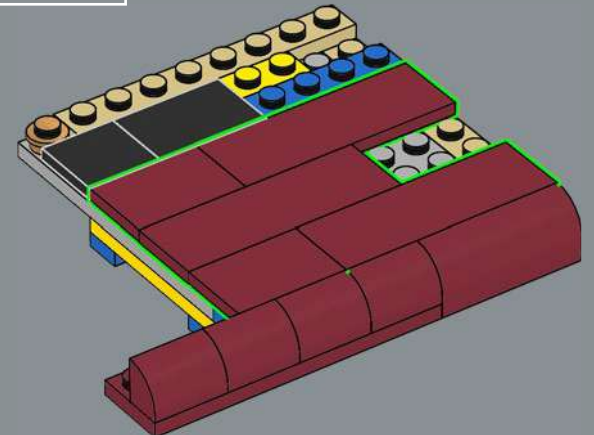

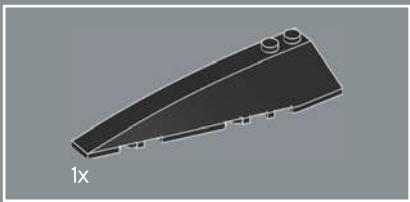

63

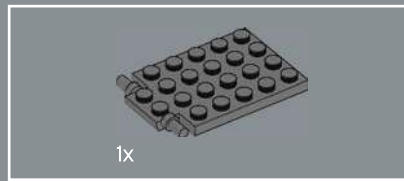
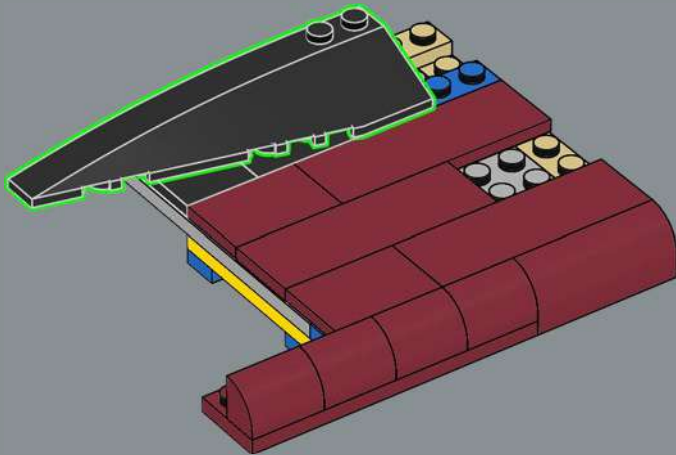

64

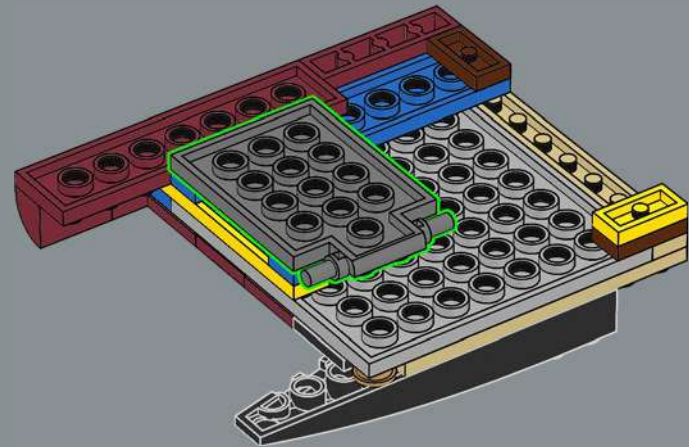

65

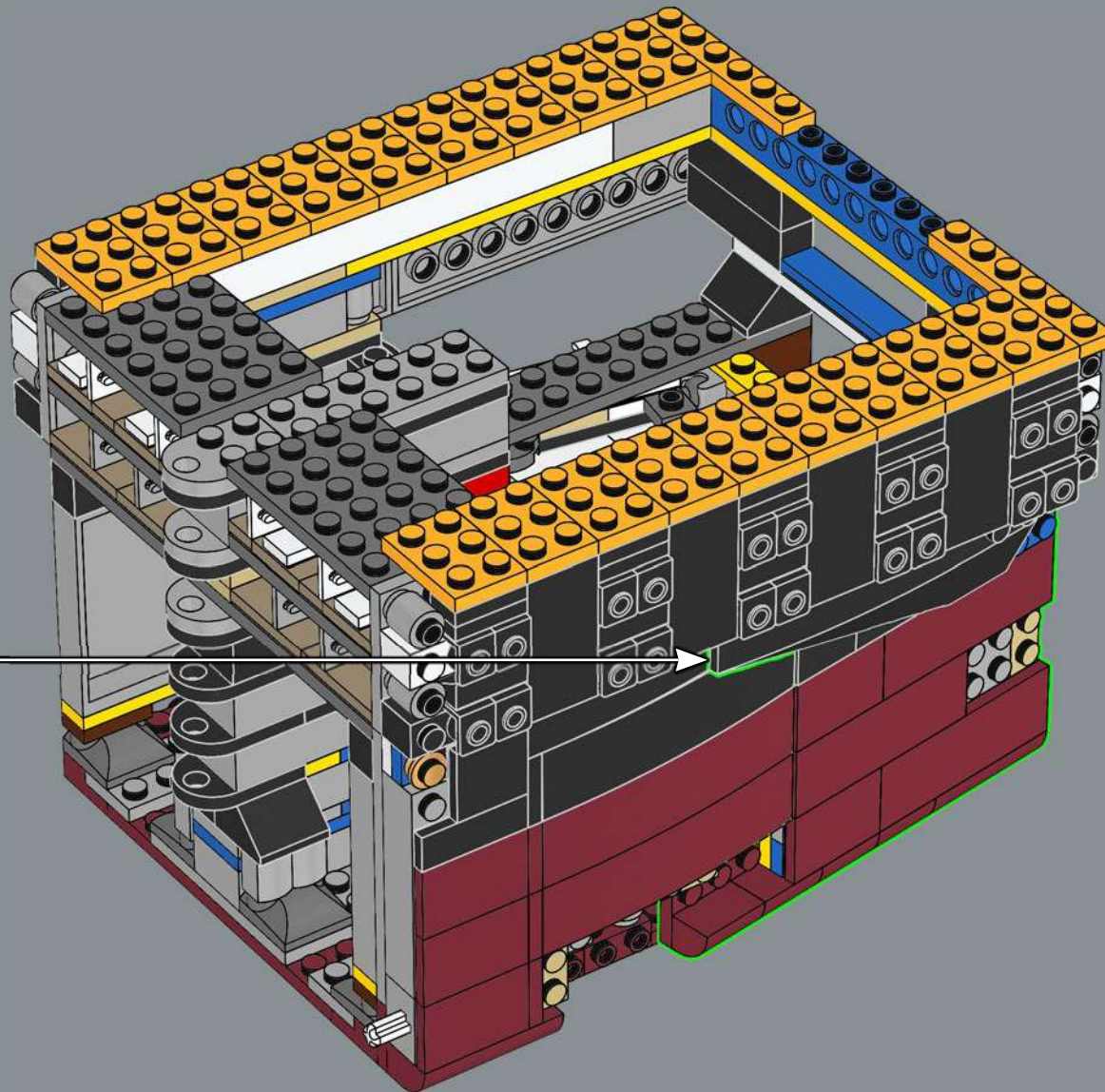

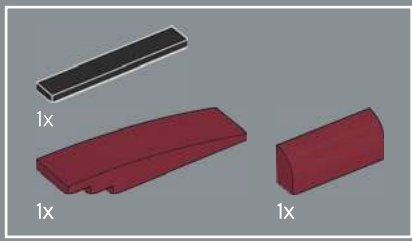

66

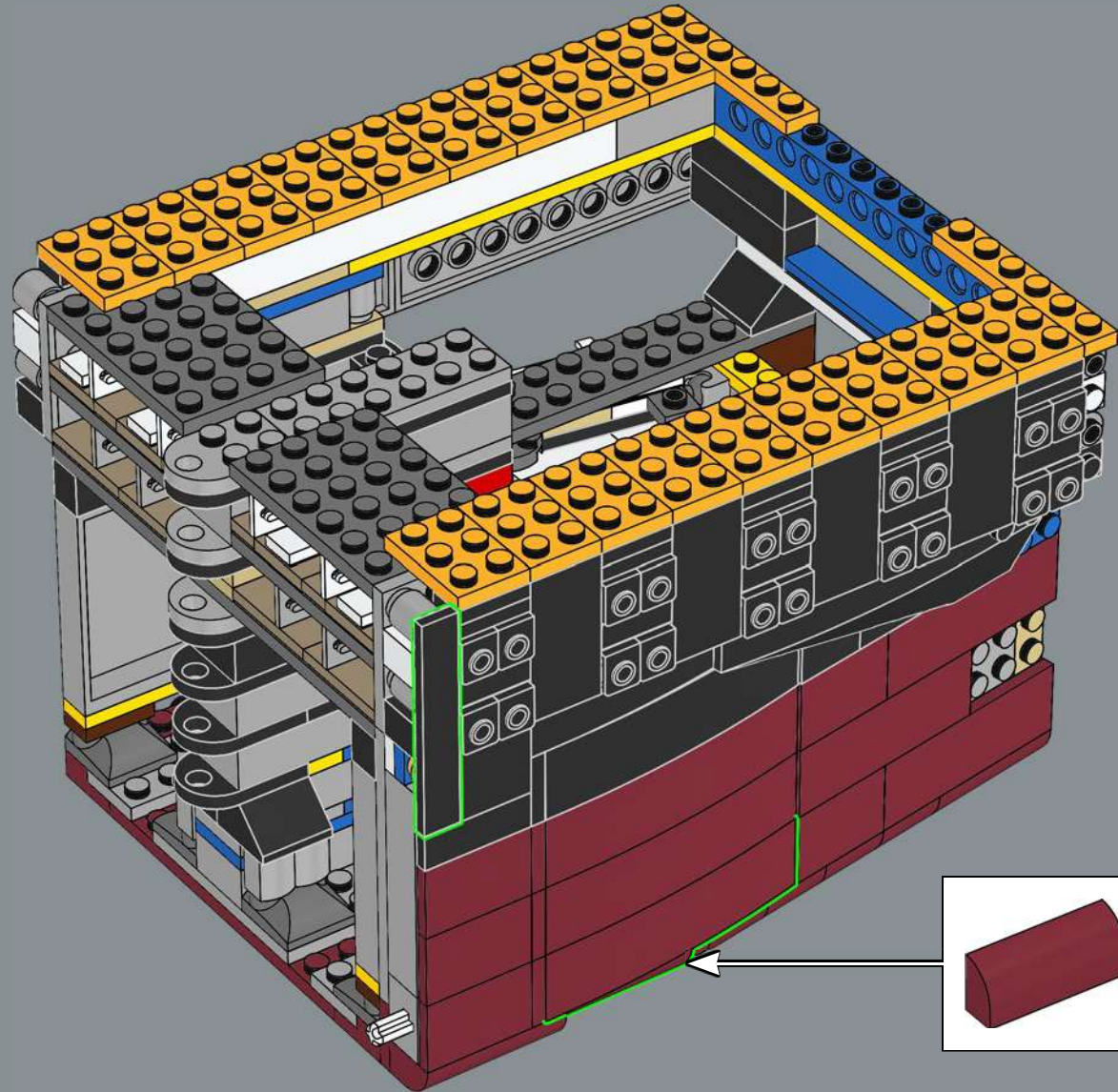

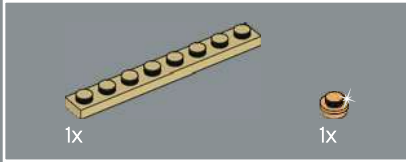
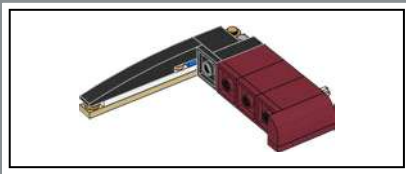

67

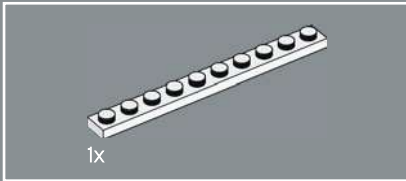
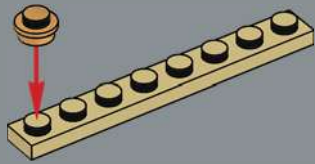

68

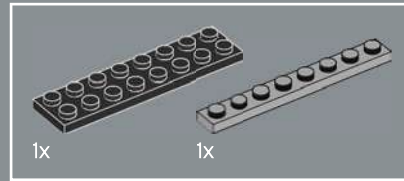
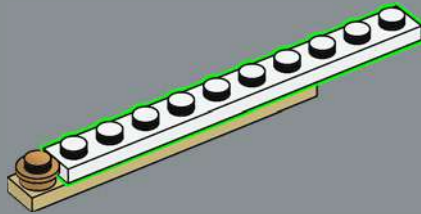

69

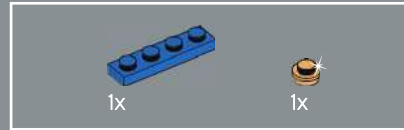
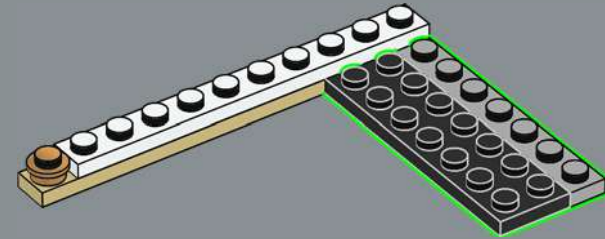

70

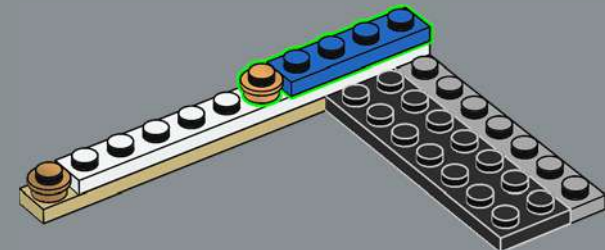

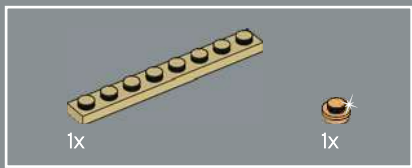

71

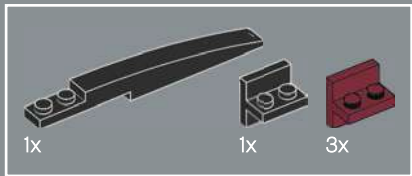
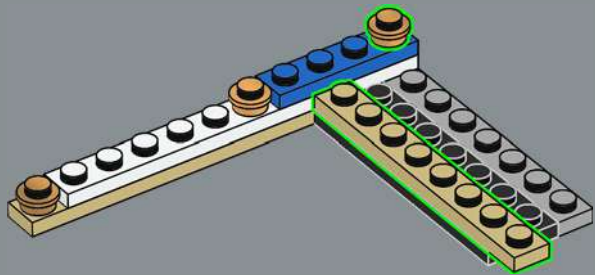

72

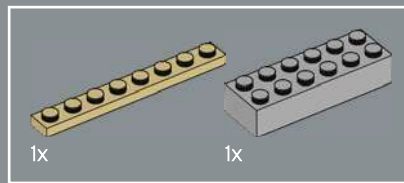
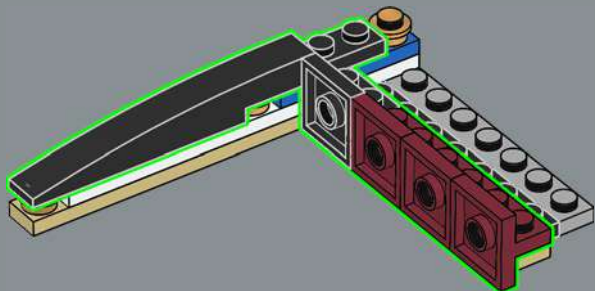

73

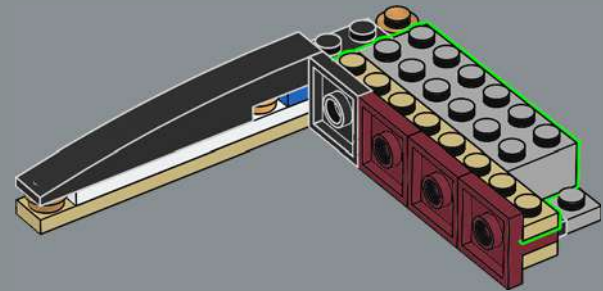

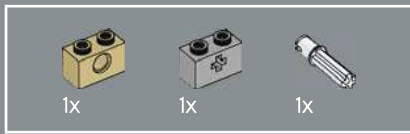

74

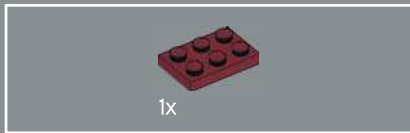
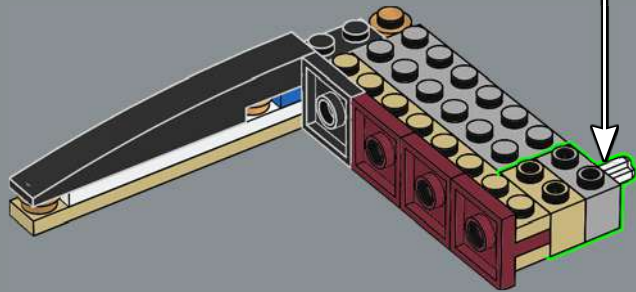
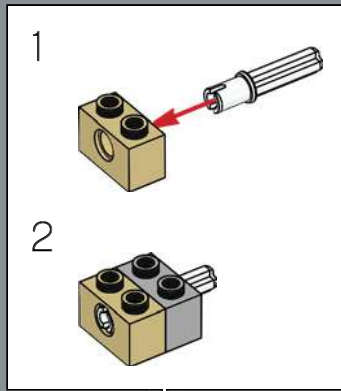

75

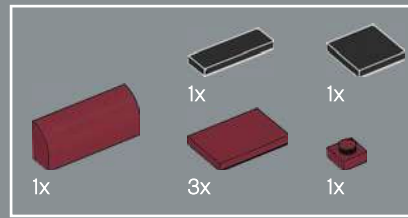
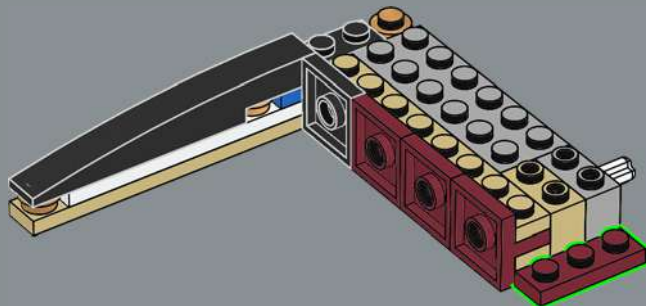

76

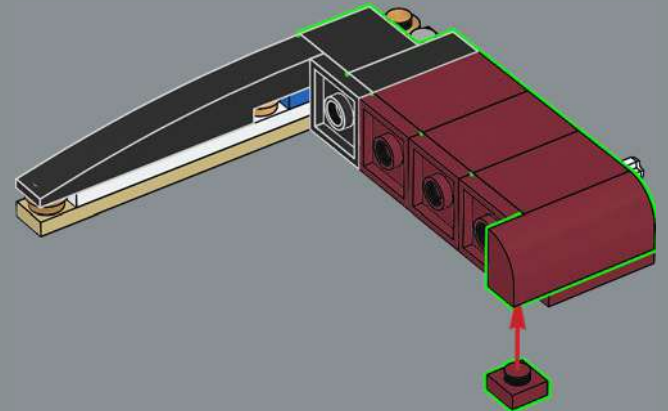

77

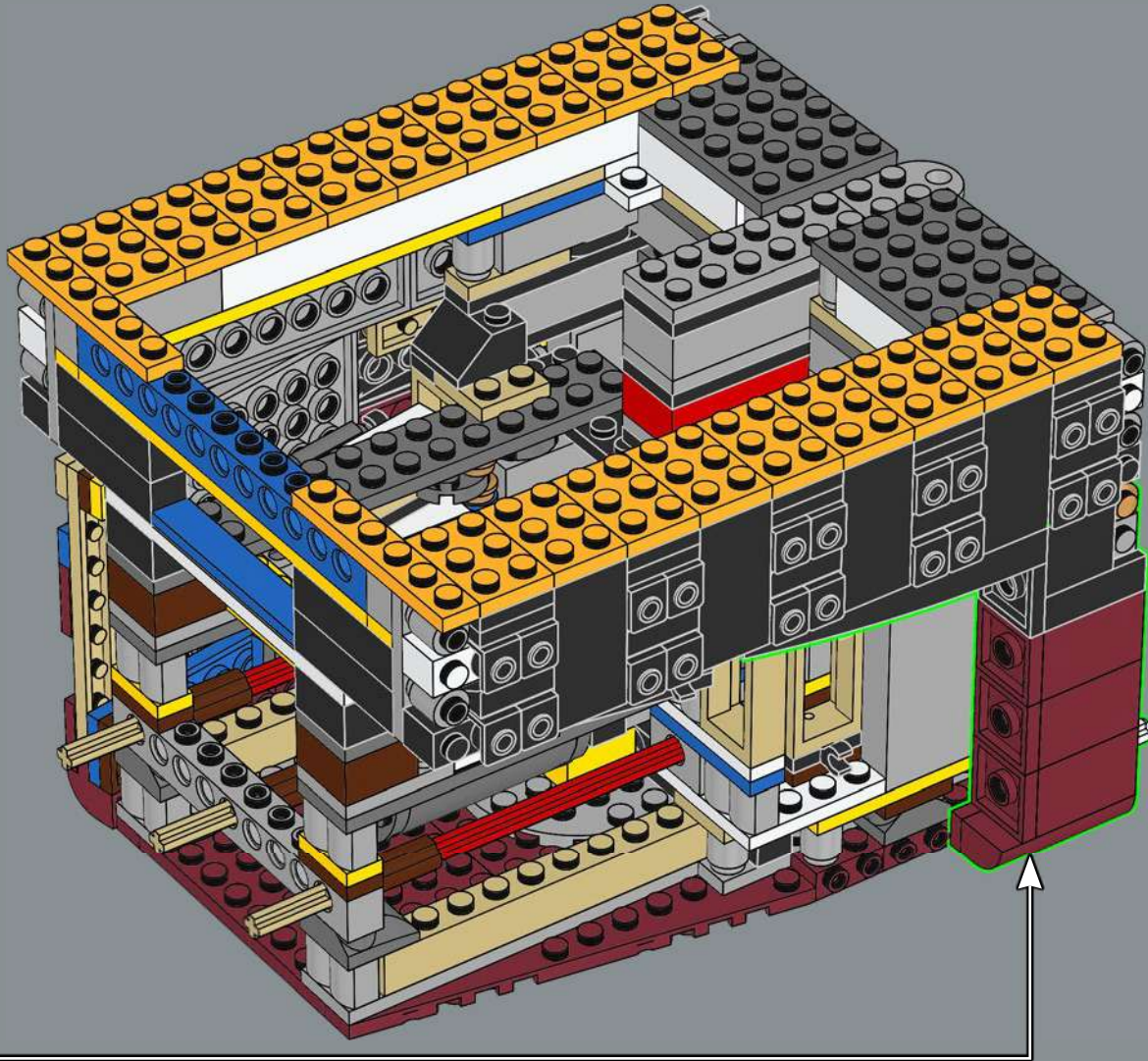

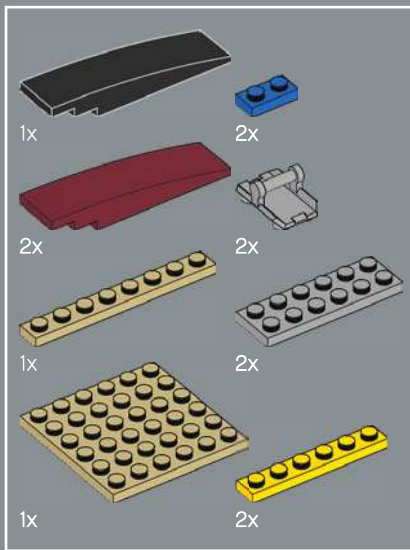

78

1

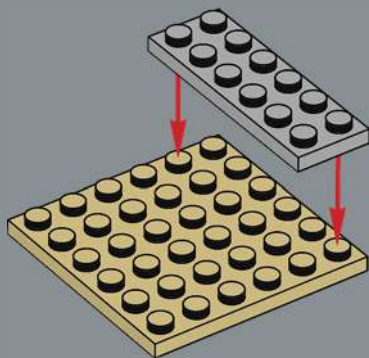

2

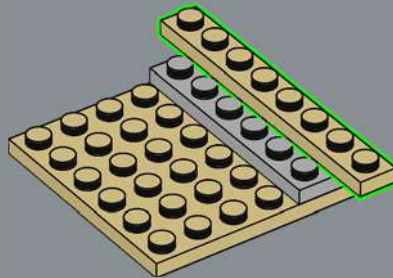

3

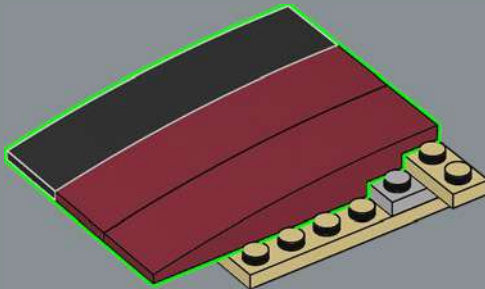

4

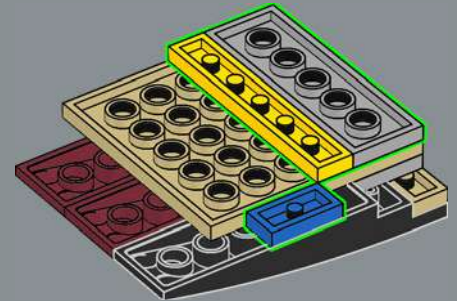

5

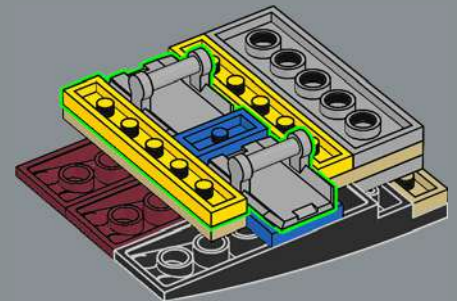

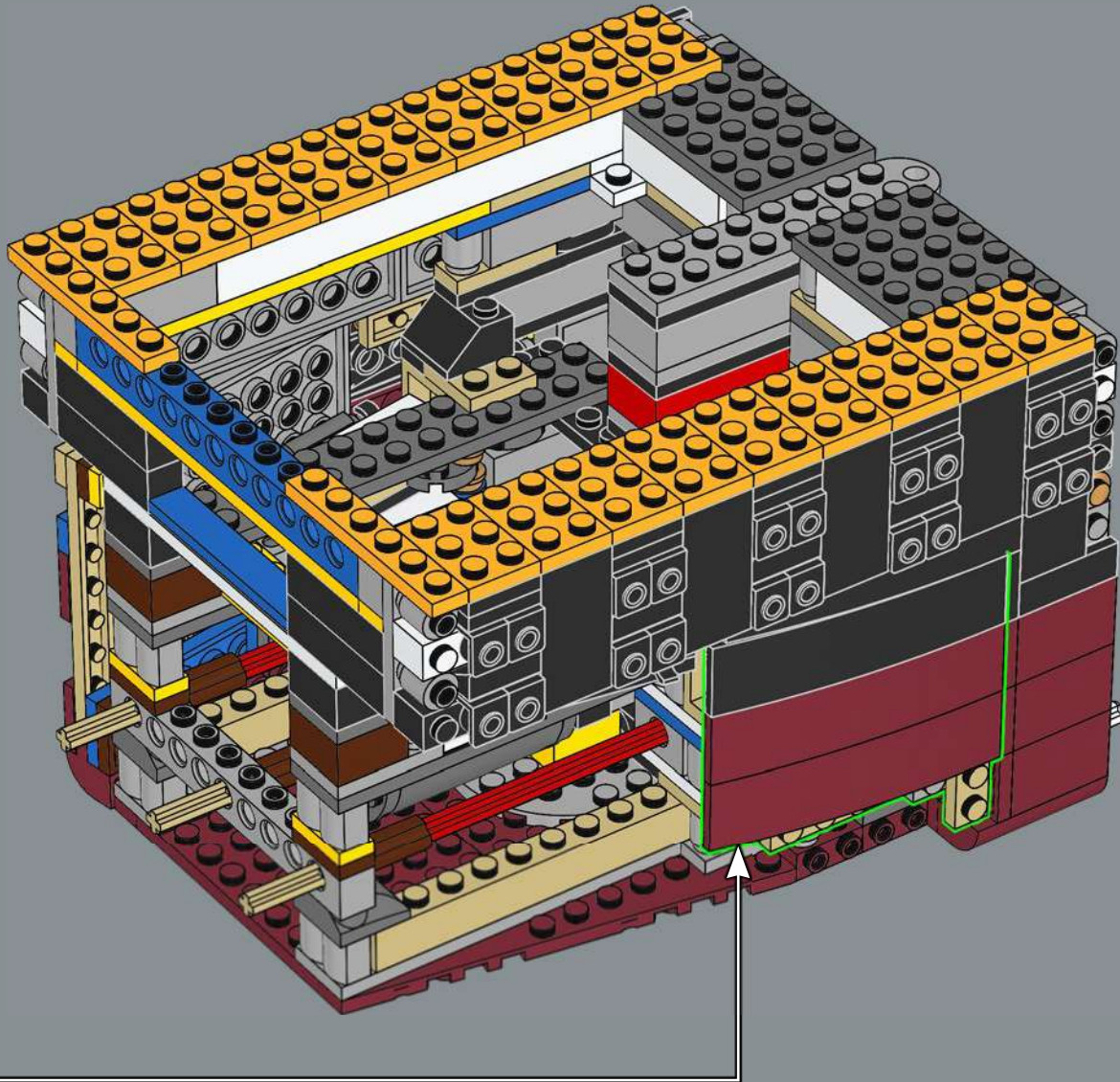

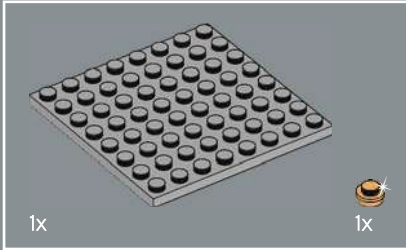
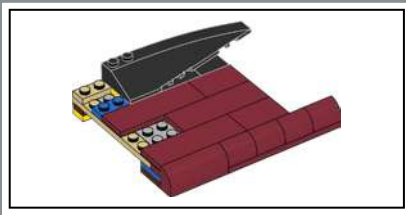

79

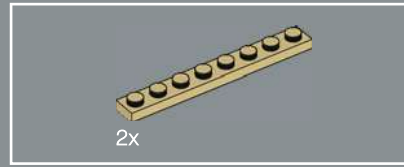
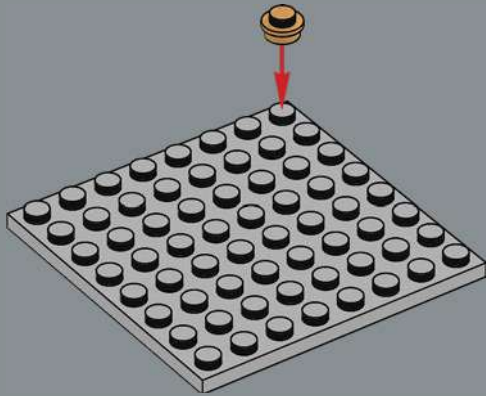

80

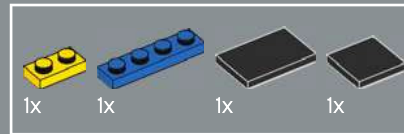
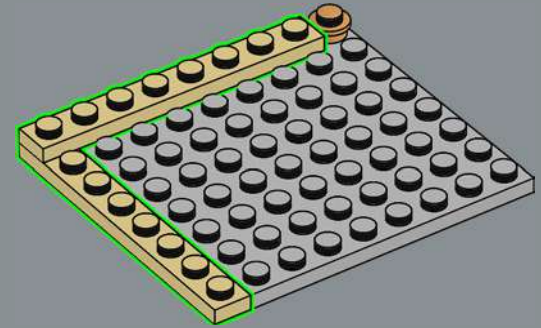

81

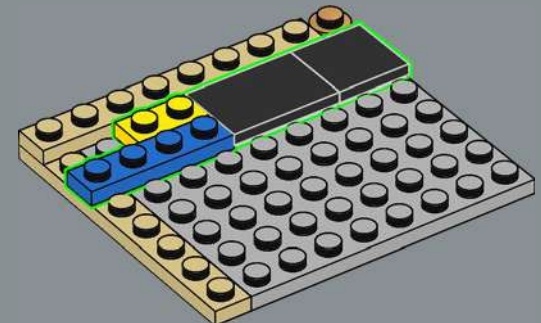

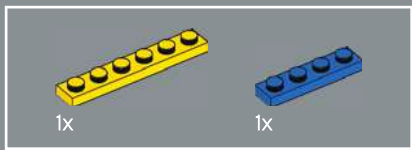

82

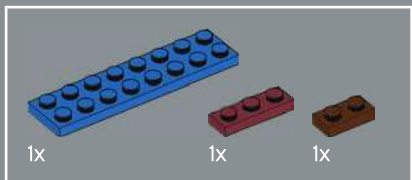
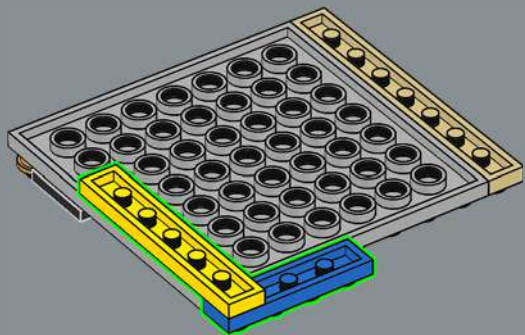

83

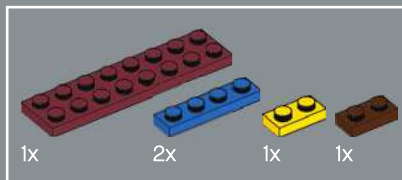
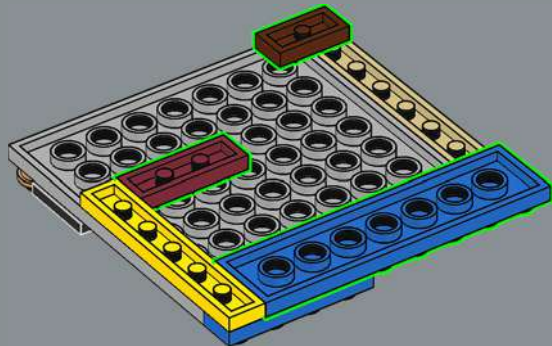

84

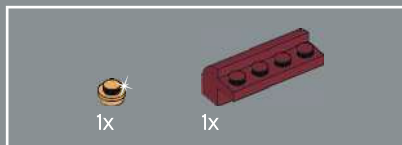
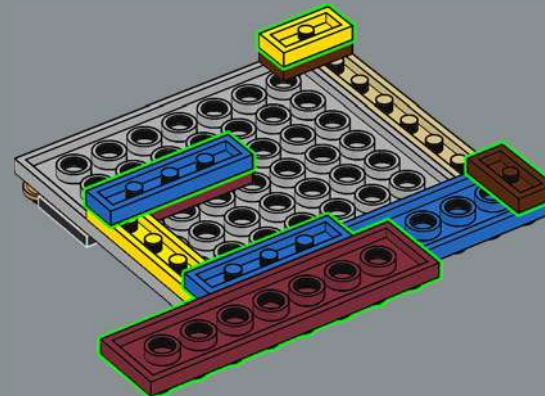

85

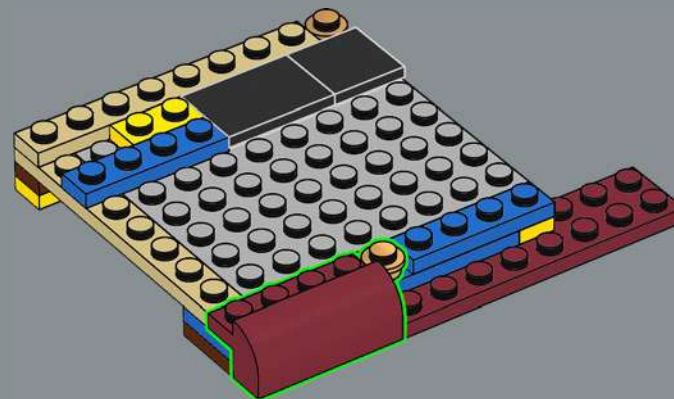

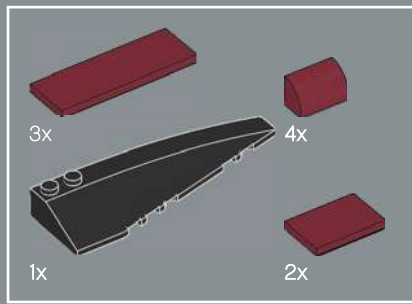

86

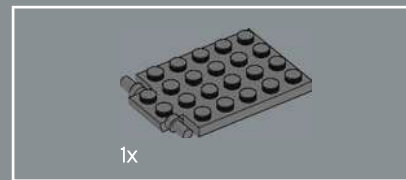
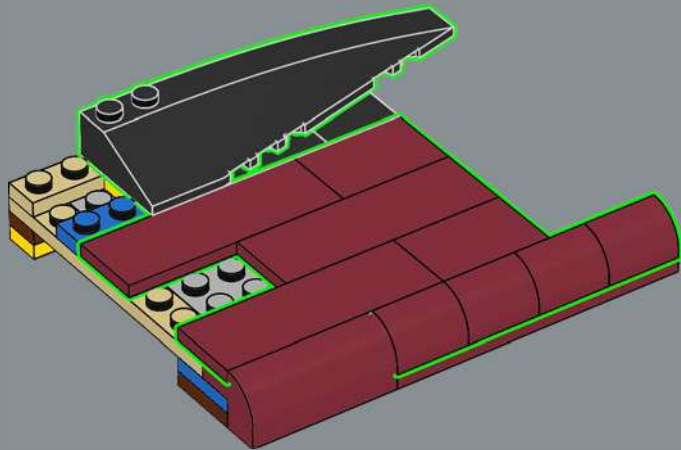

87

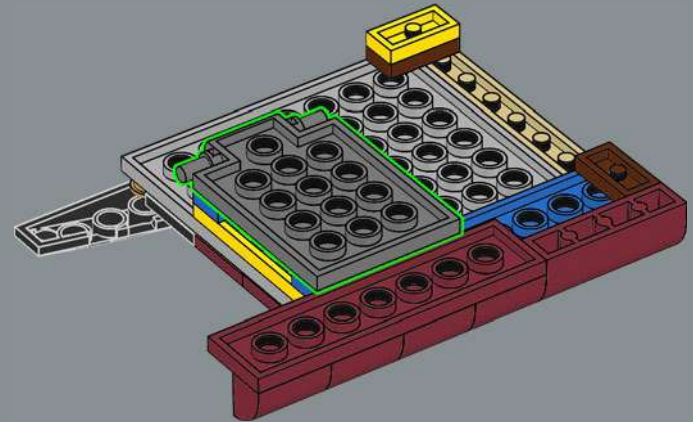

The *Titanic* was 640 km (400 miles) from land when she struck the iceberg.

88

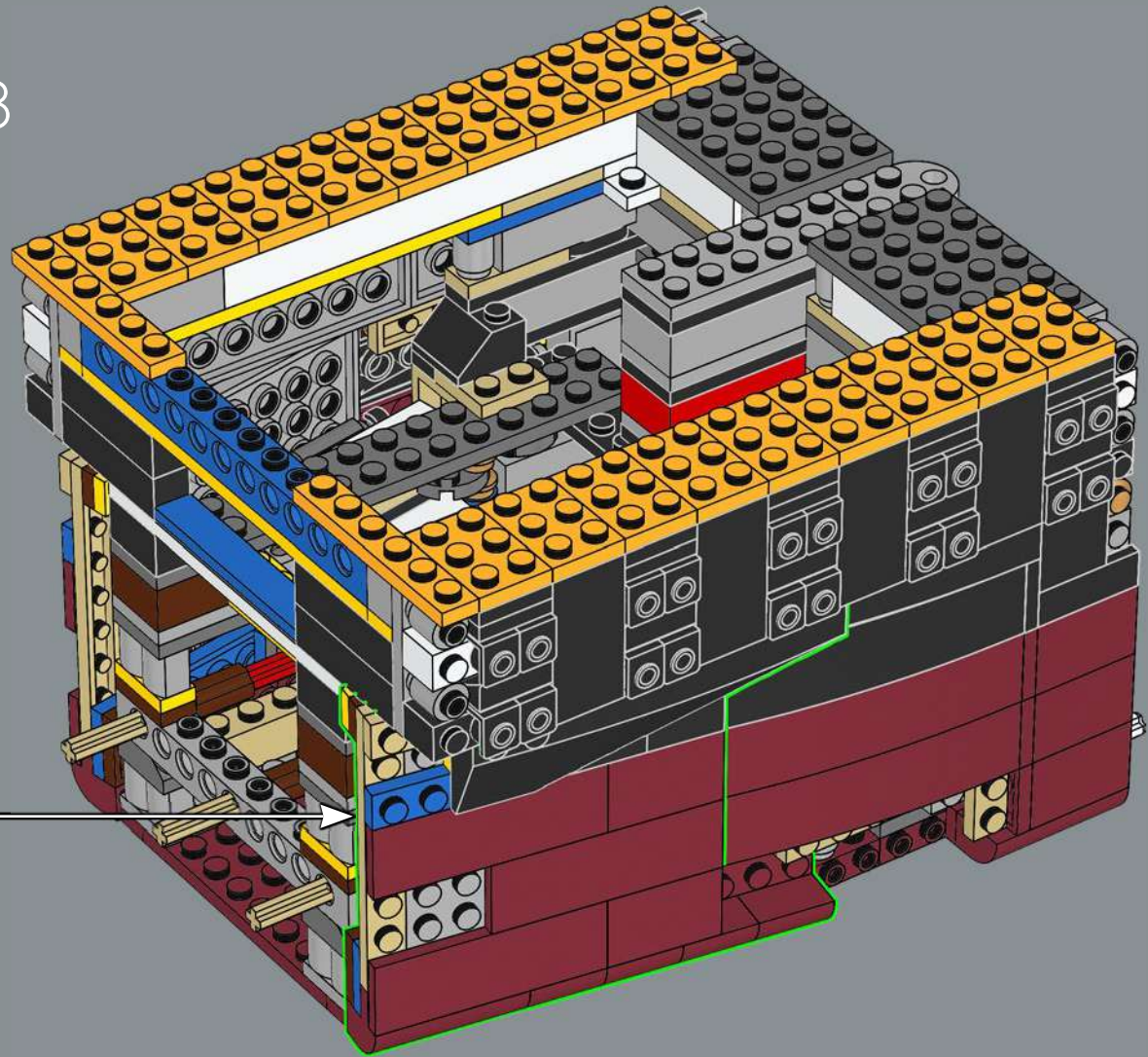

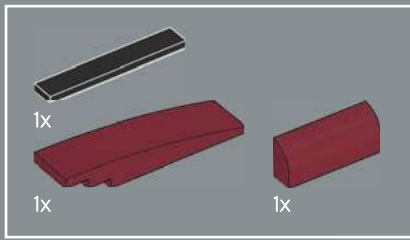

89

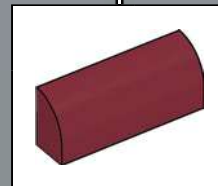
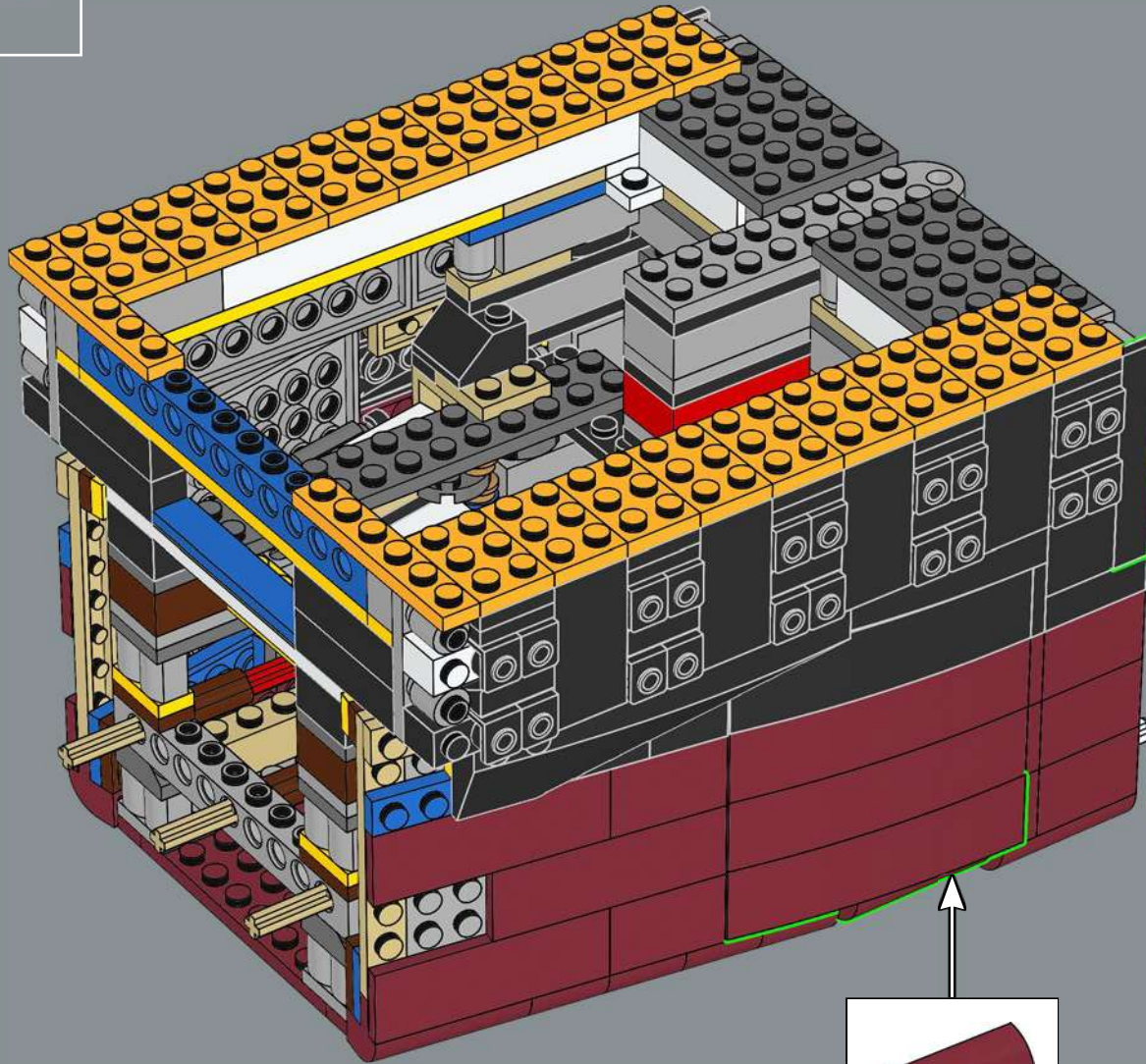

32

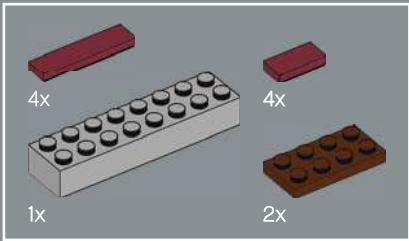

90

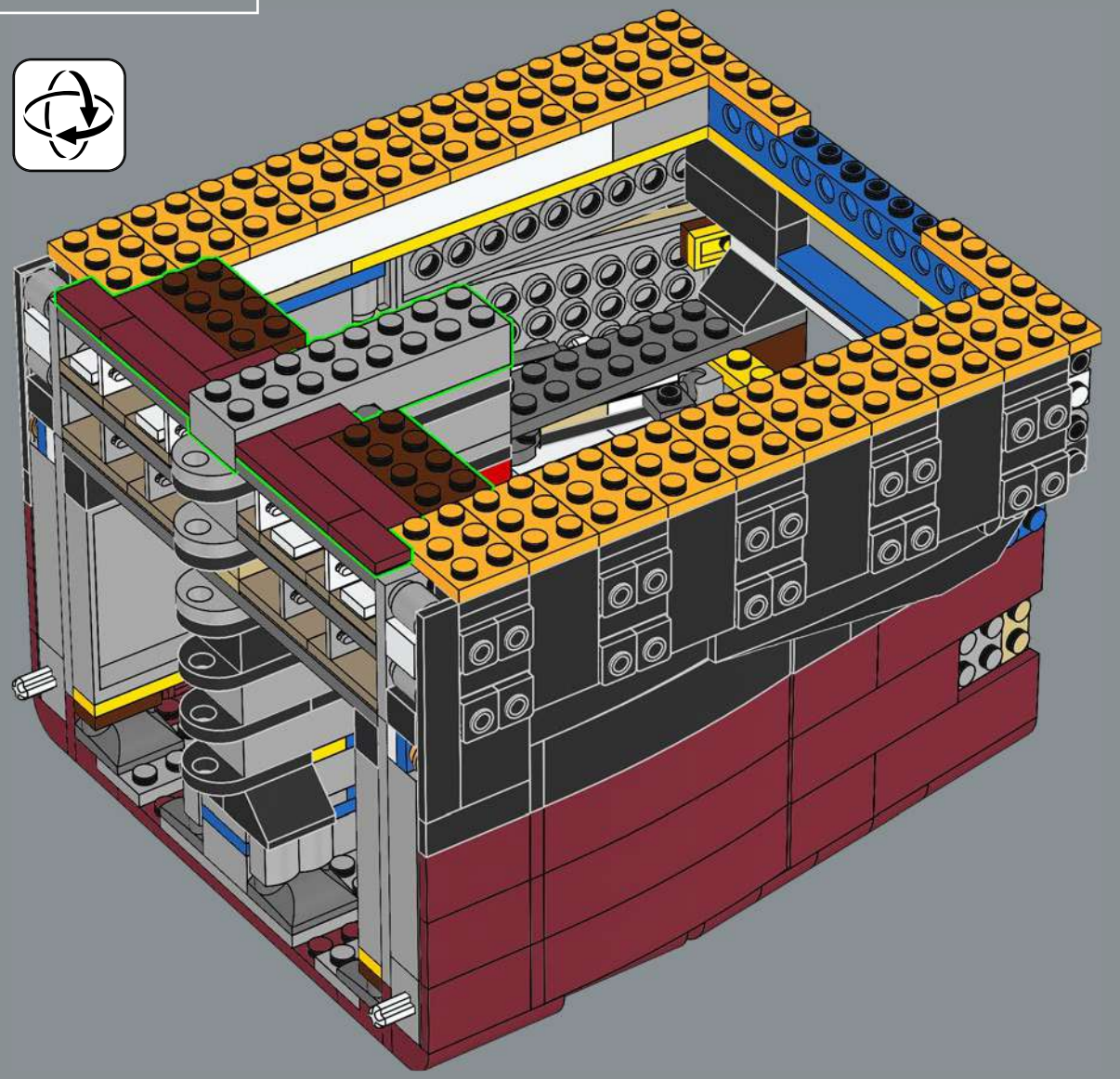

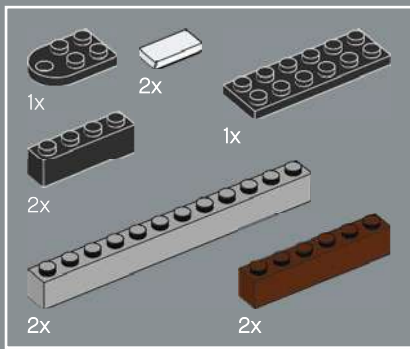

91

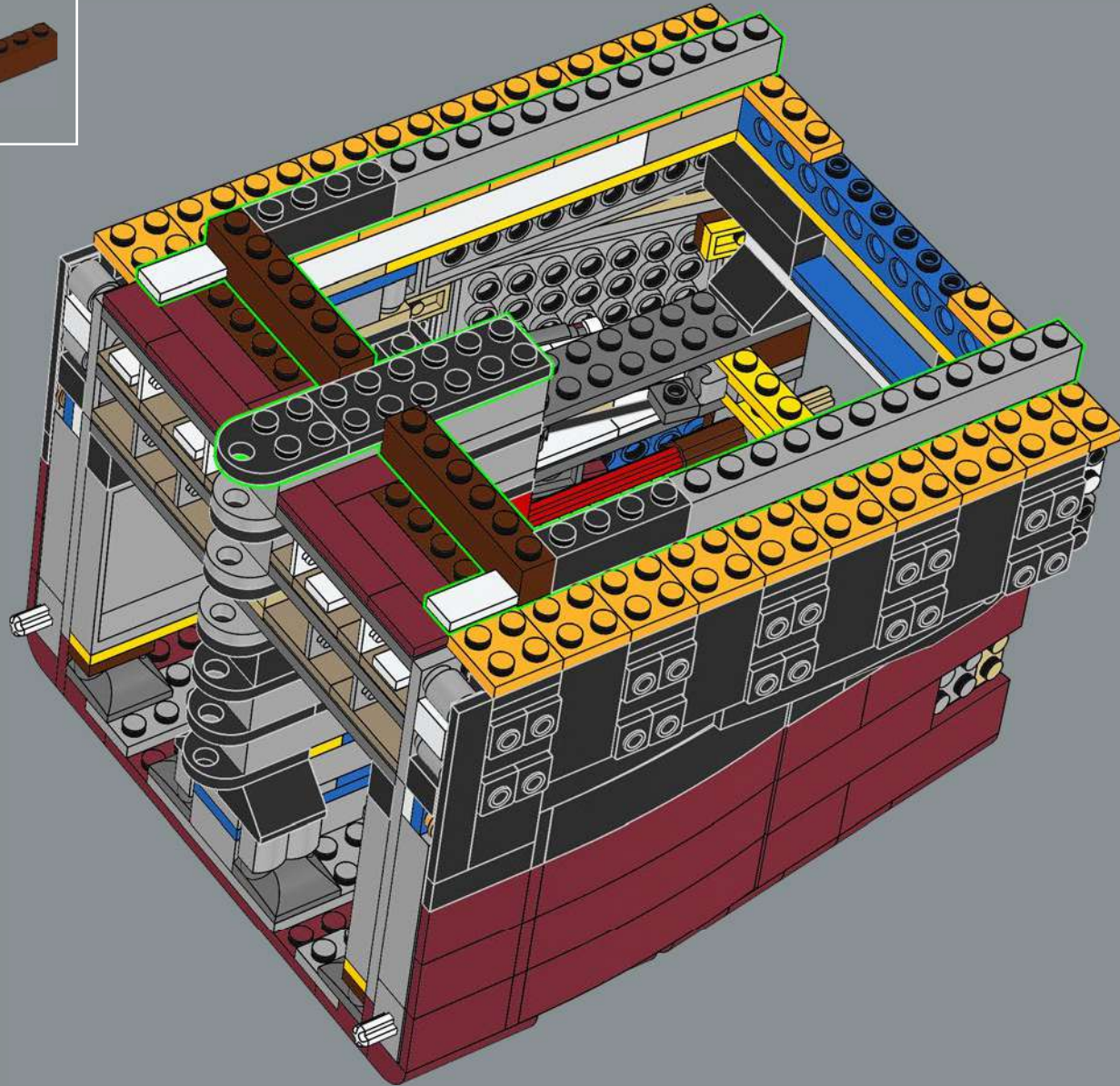



18x

93

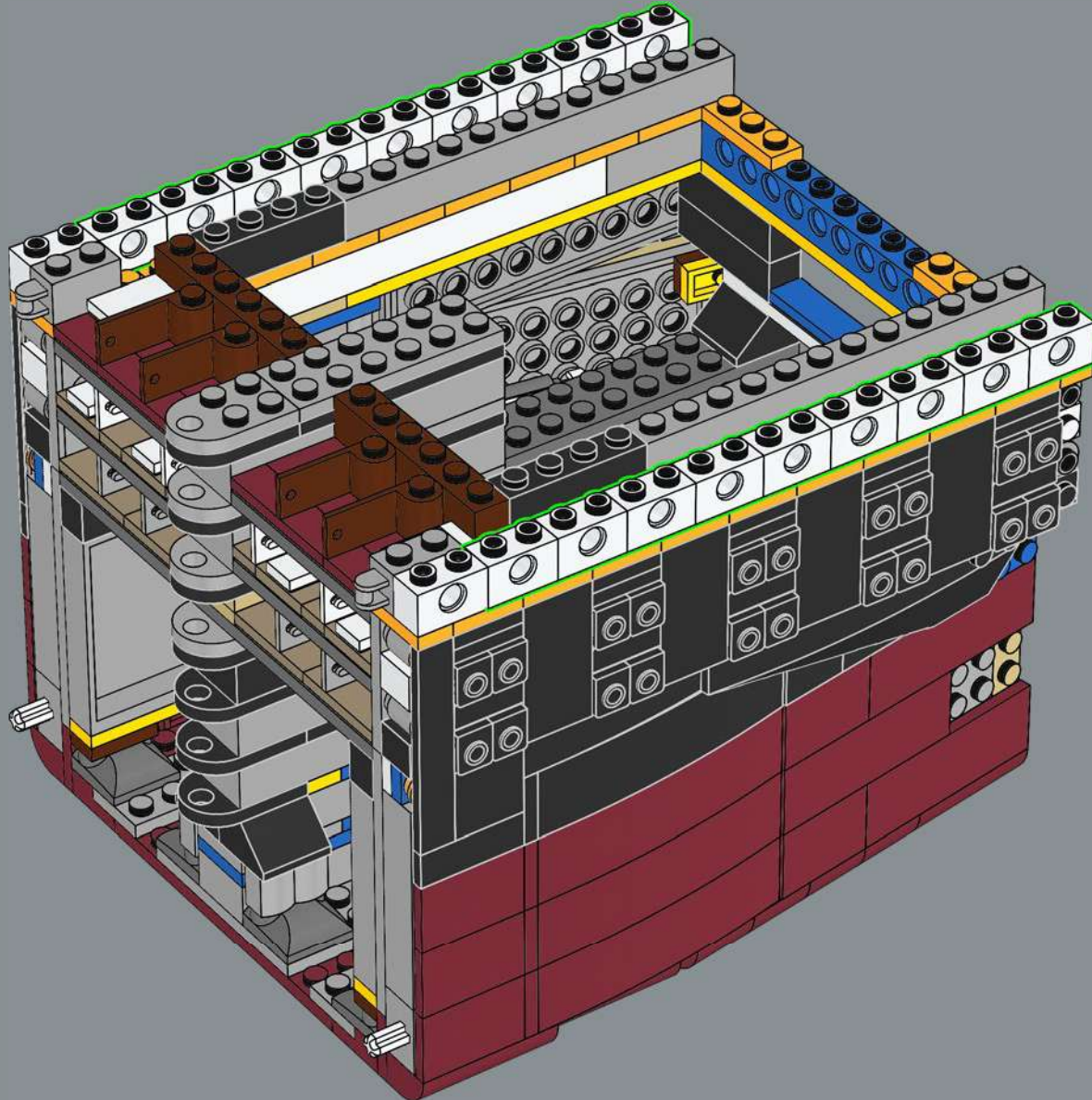

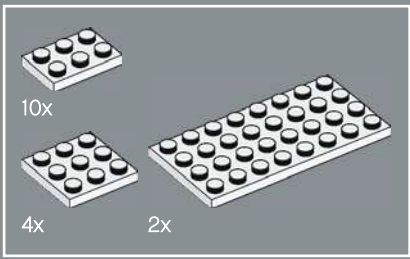

94

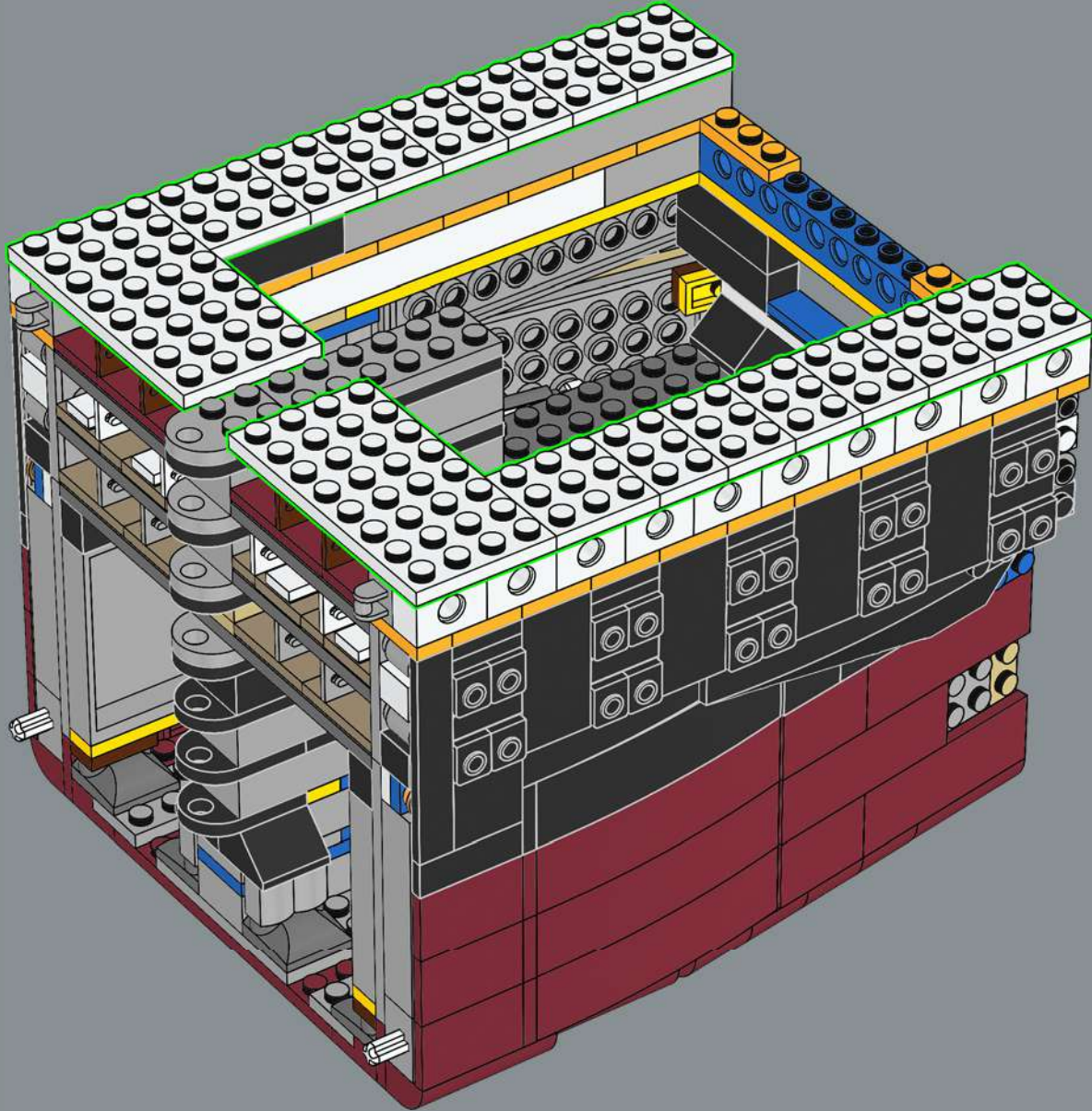

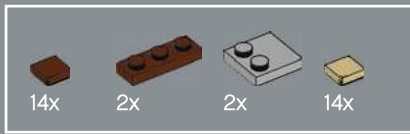

95

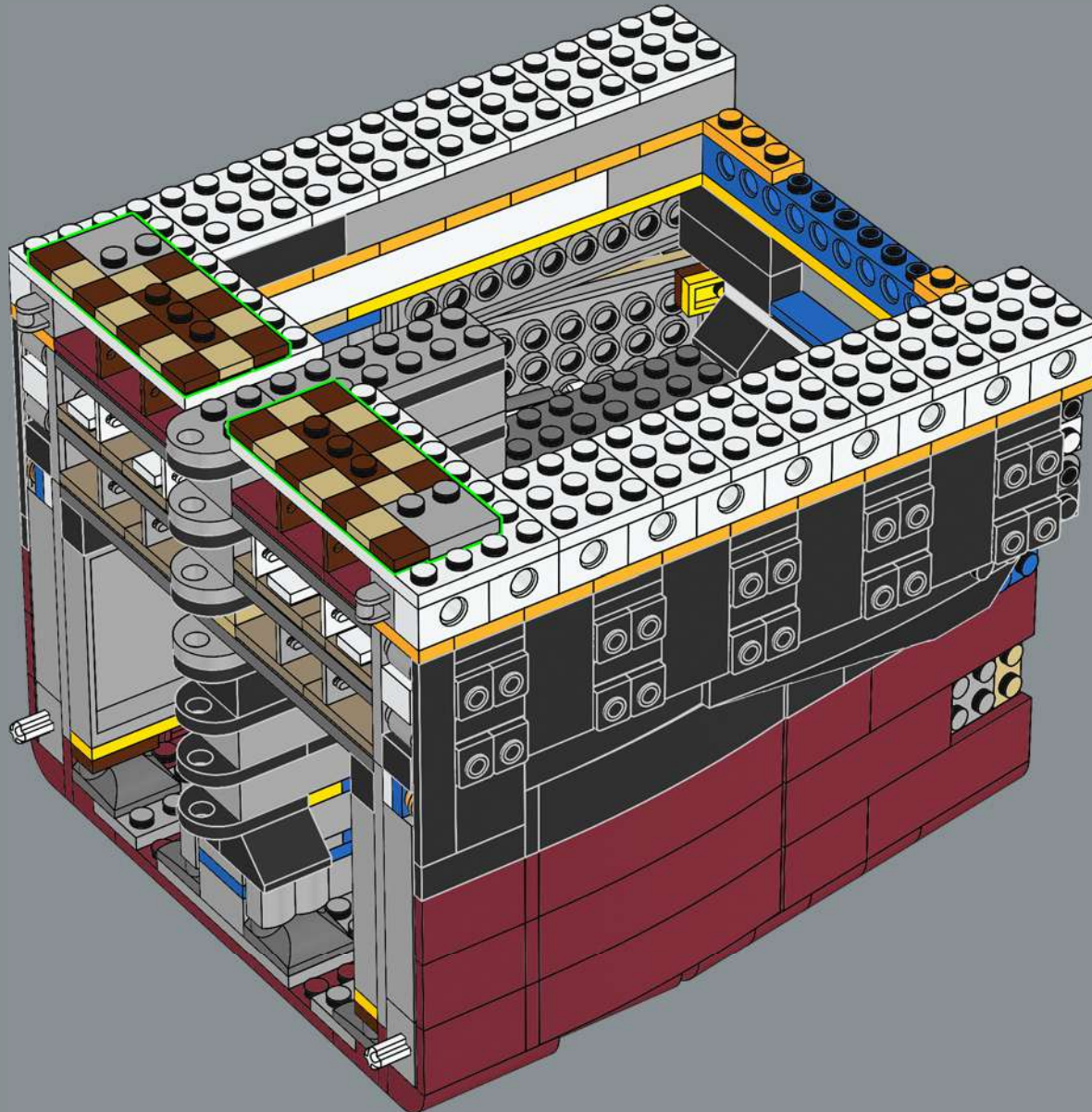

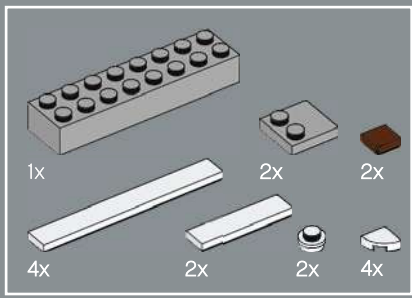

96

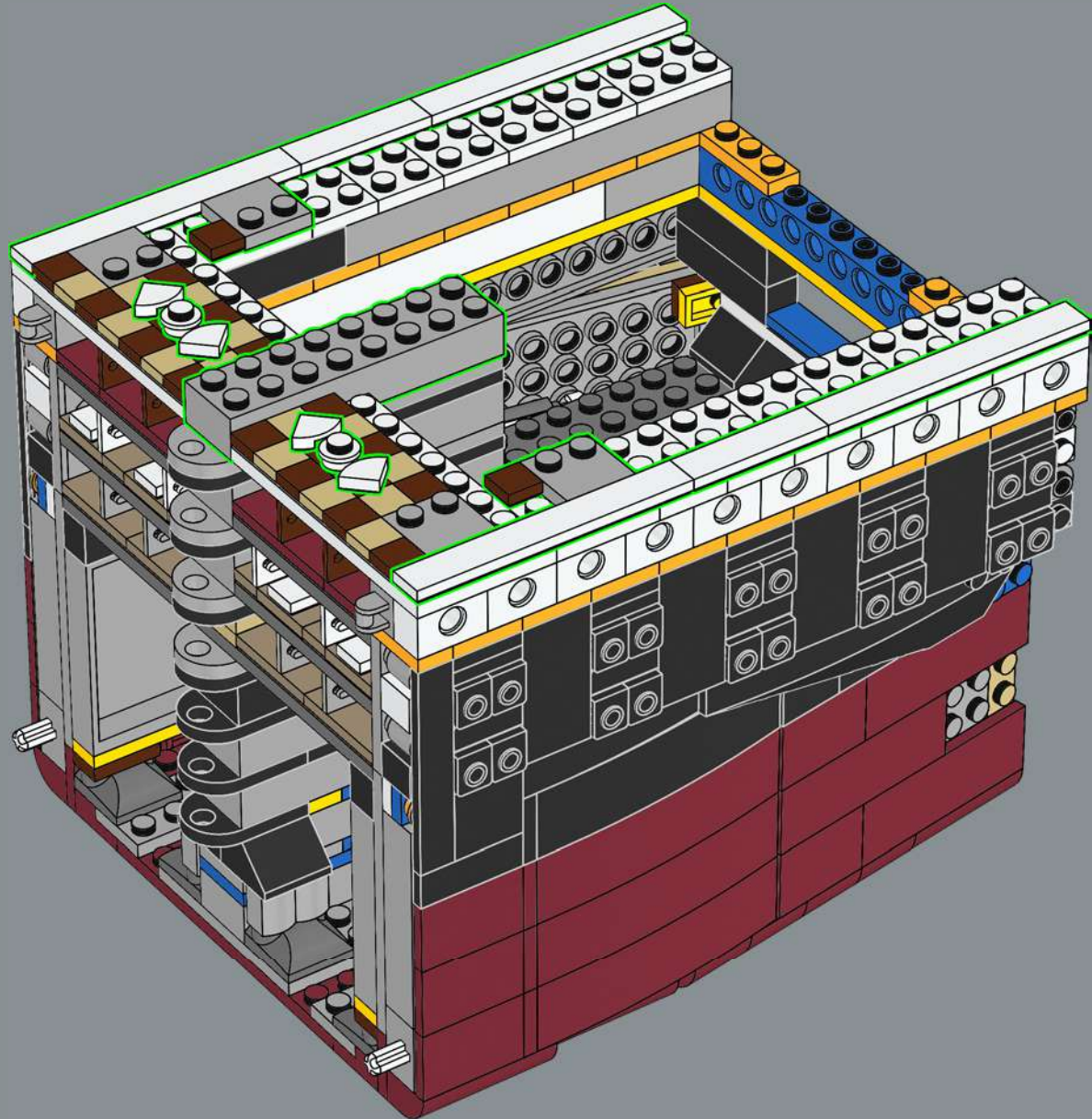

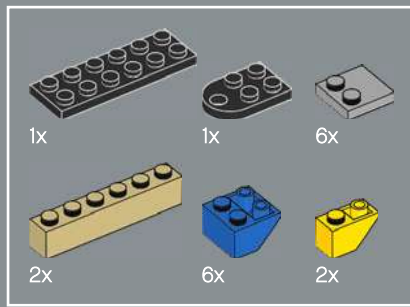

97

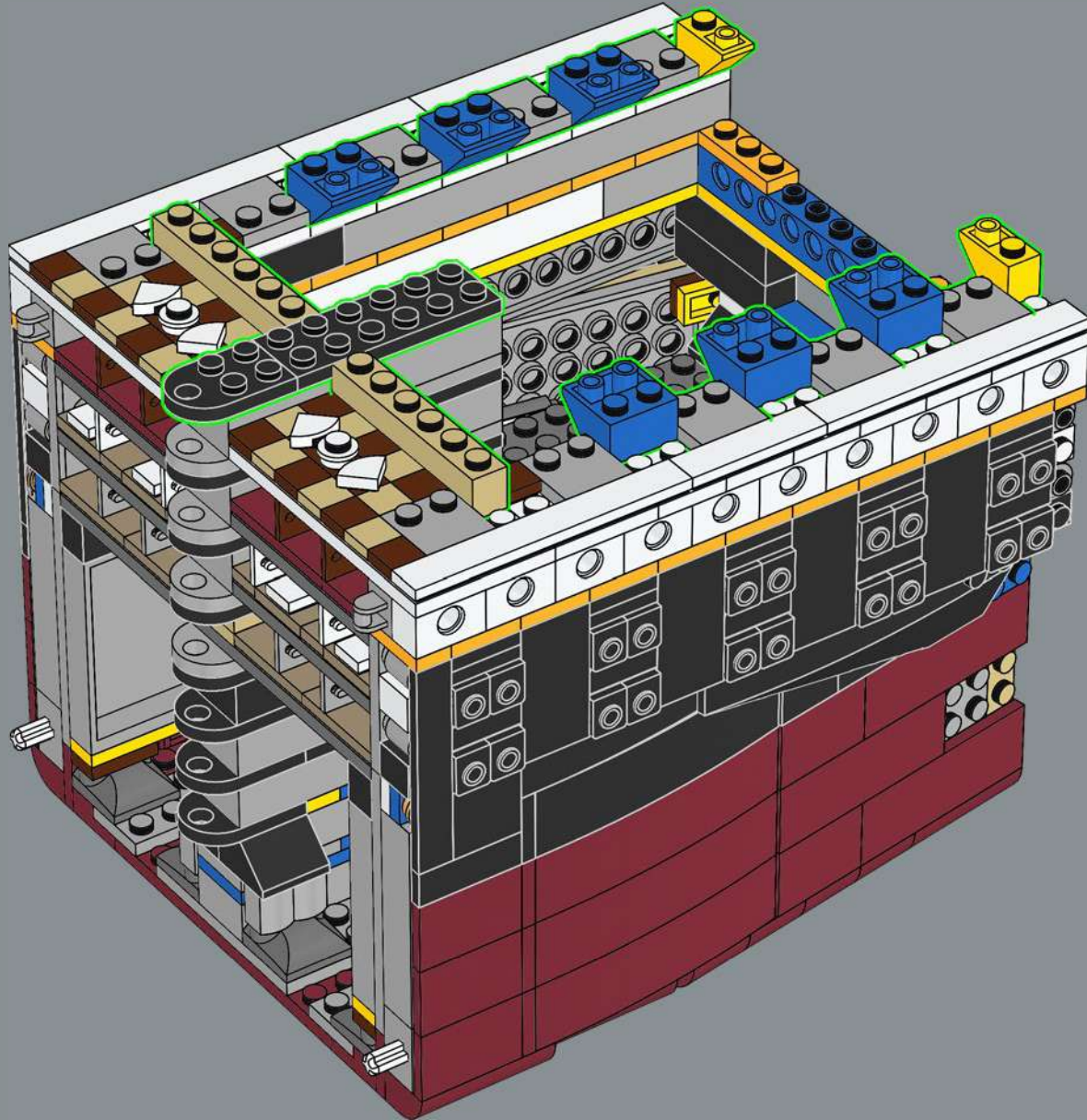

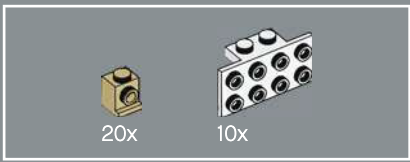

98

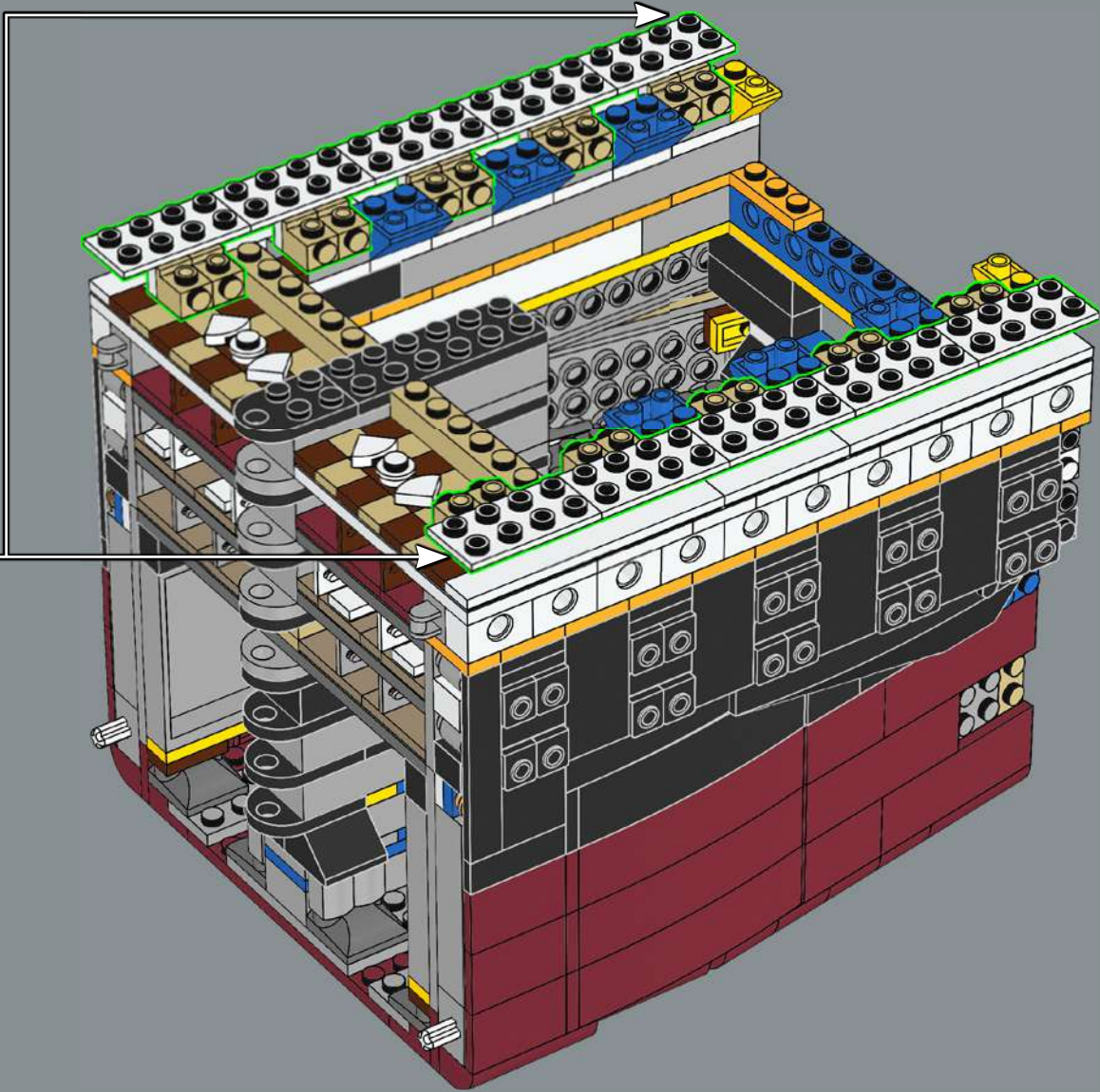
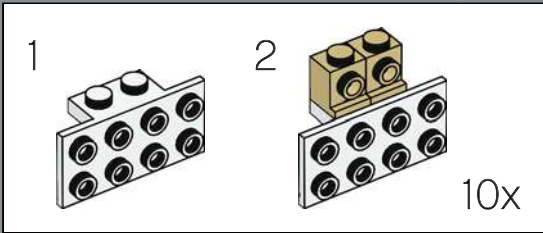



99

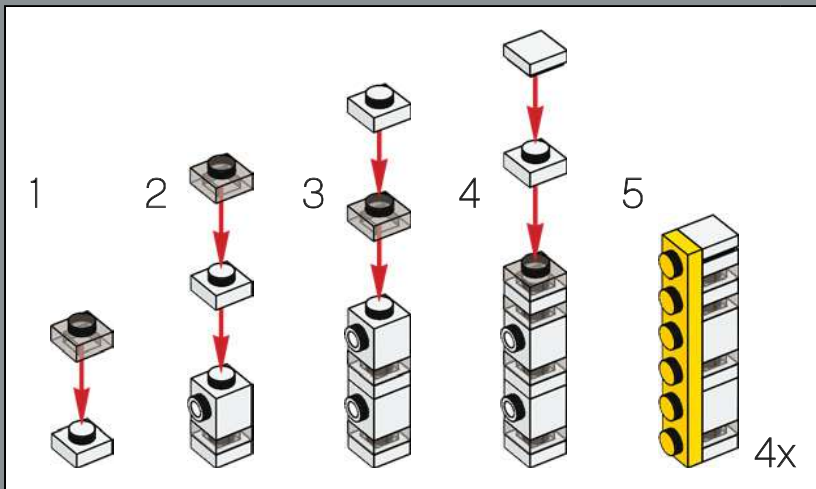
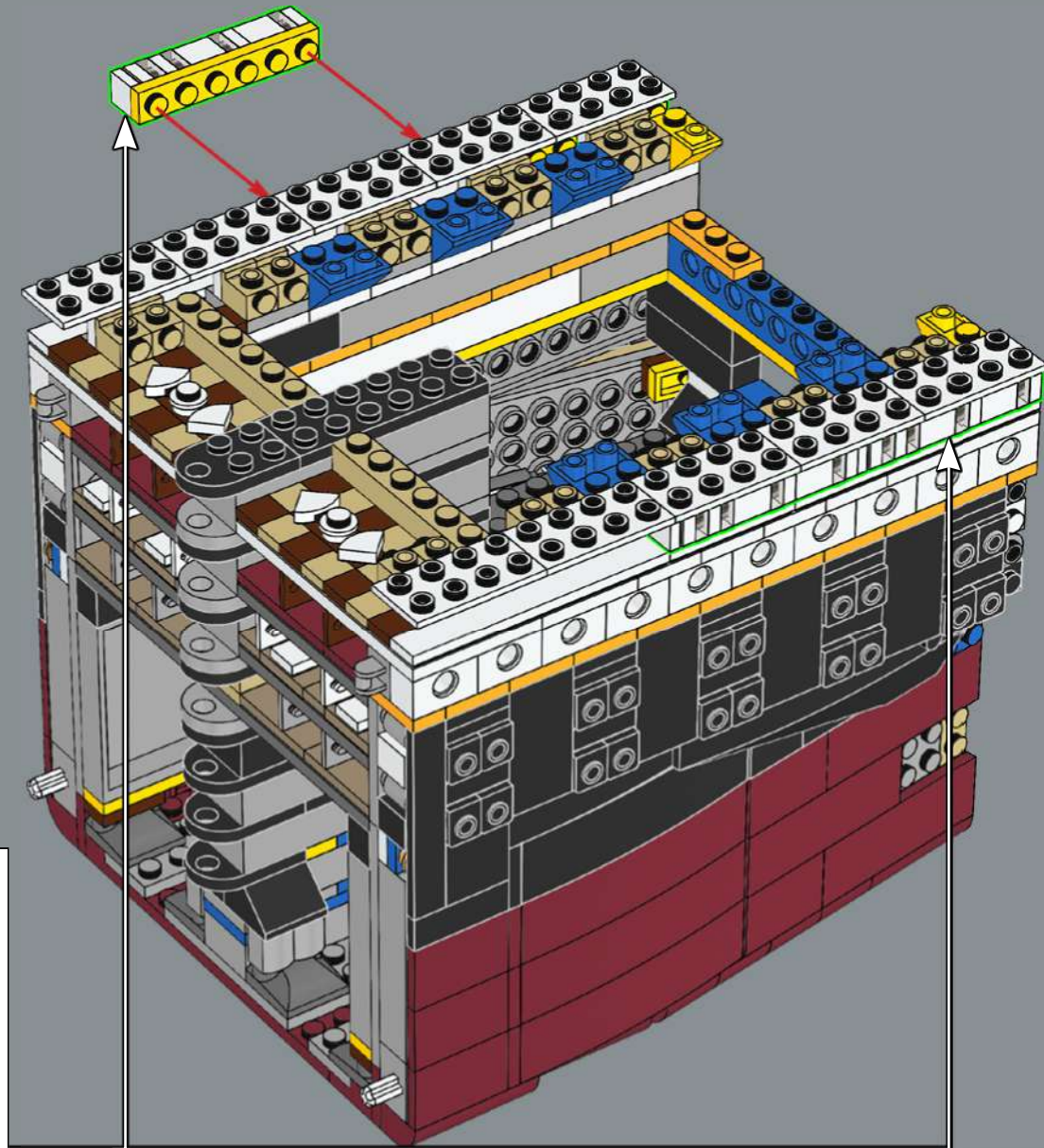

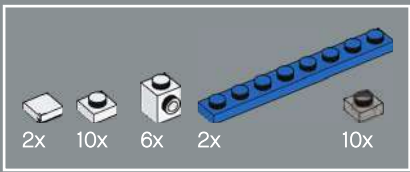

100

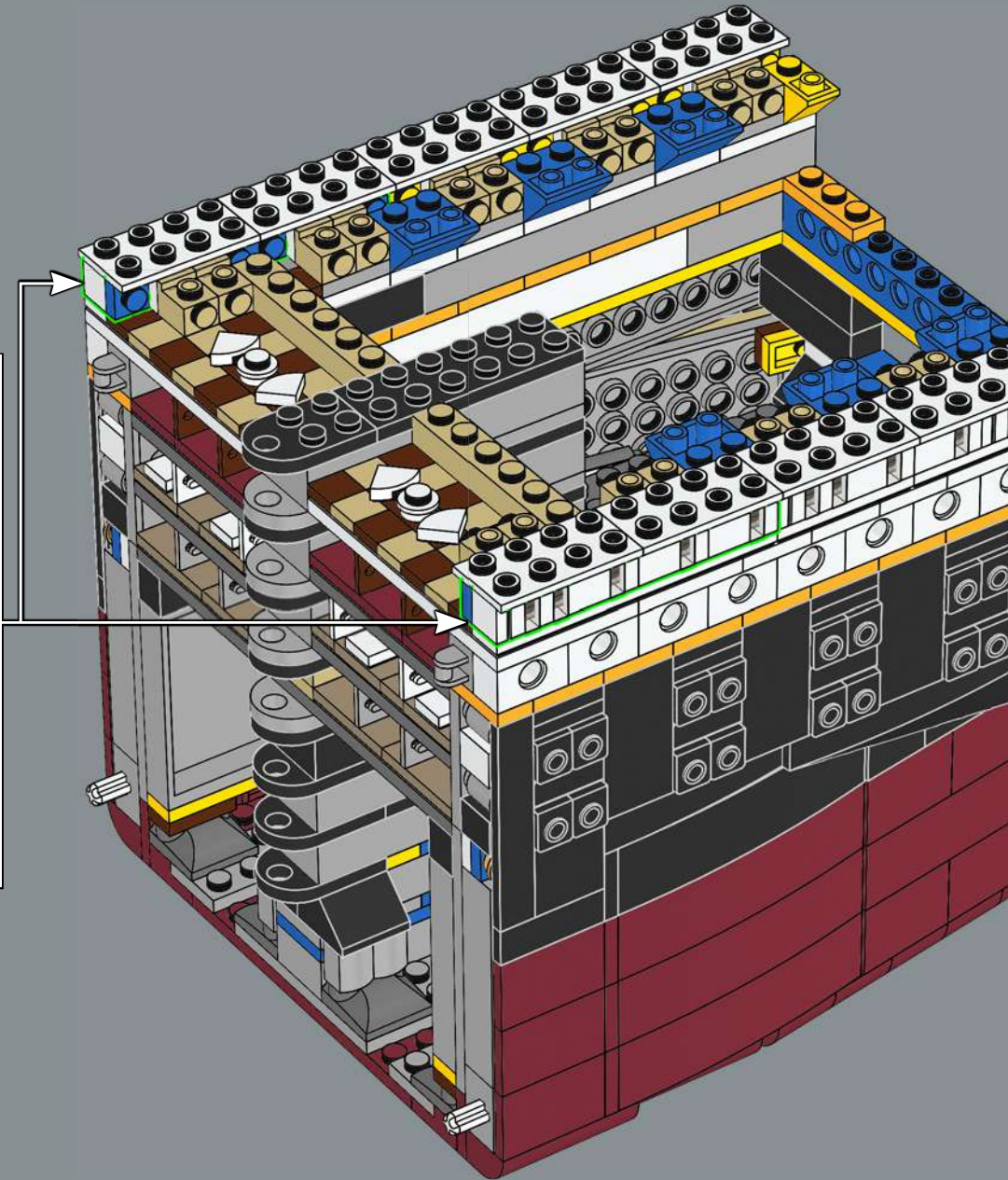
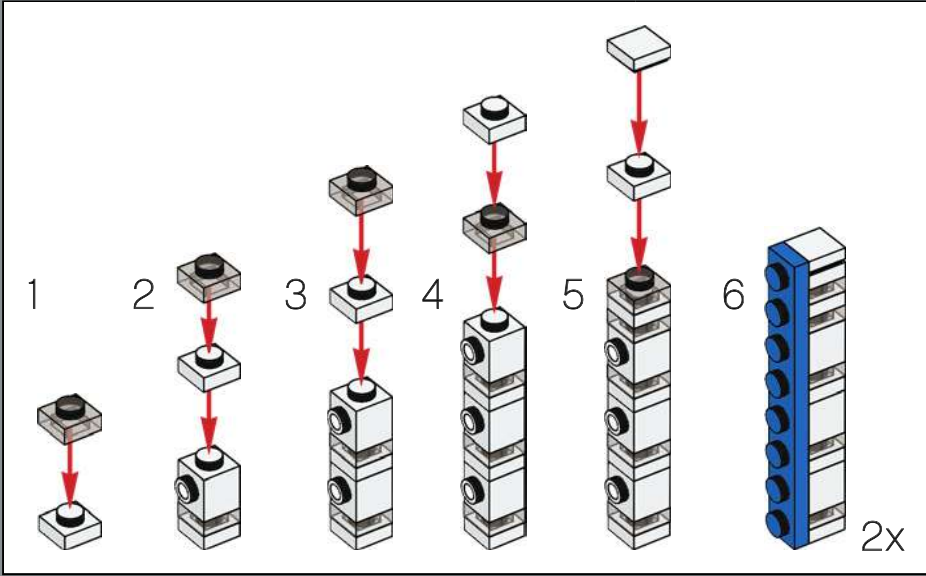

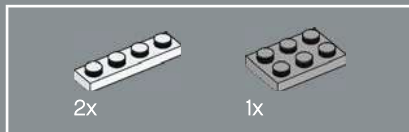
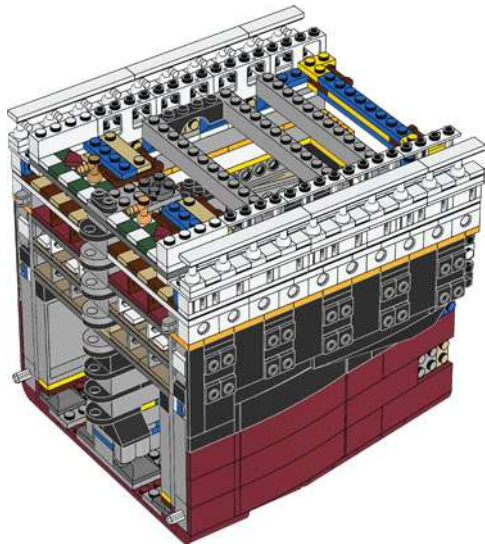
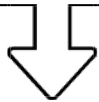

101

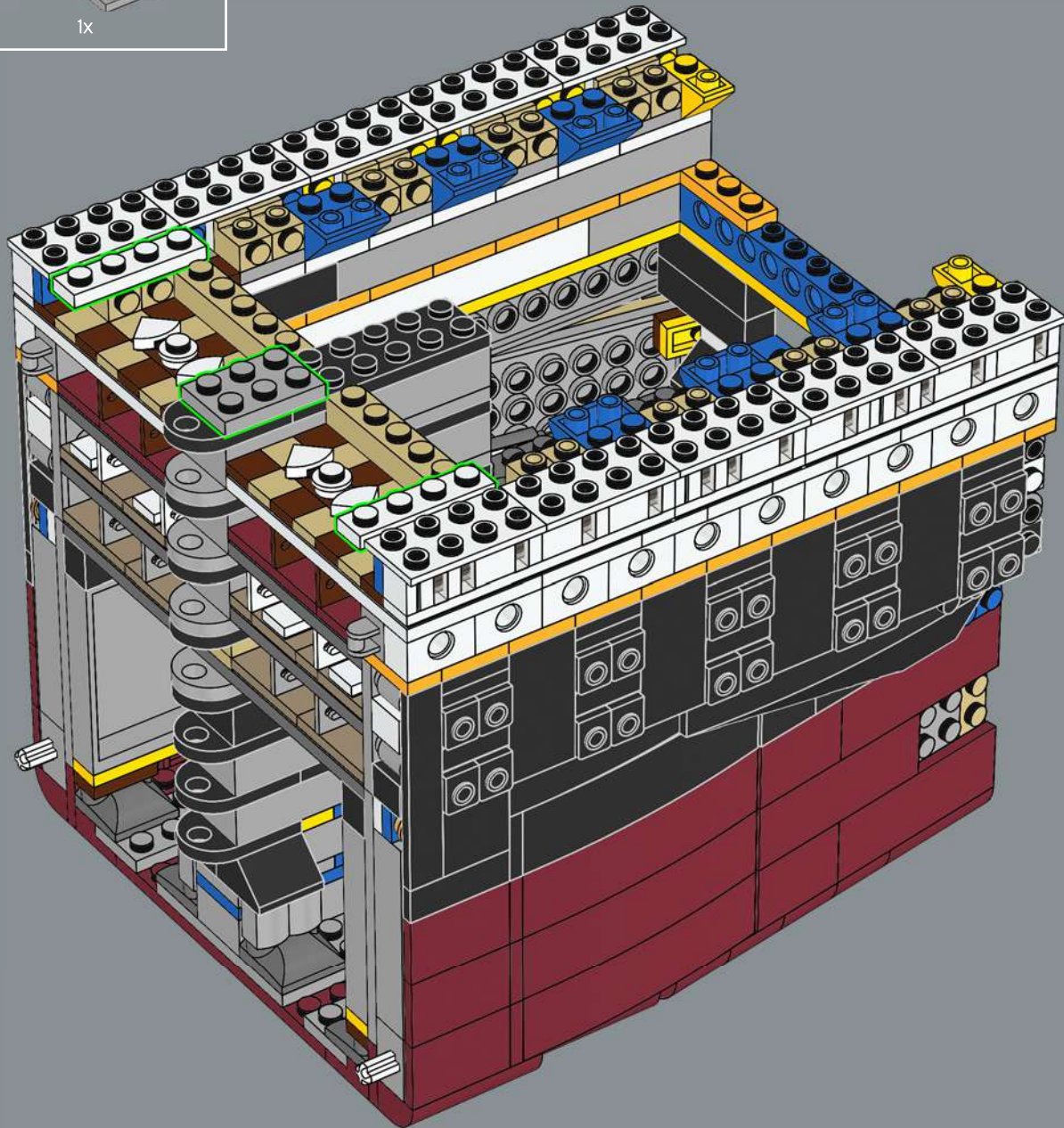

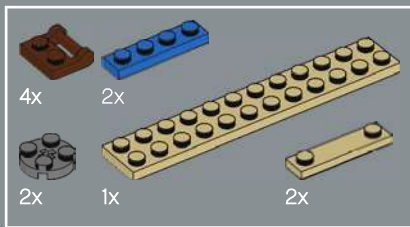

102

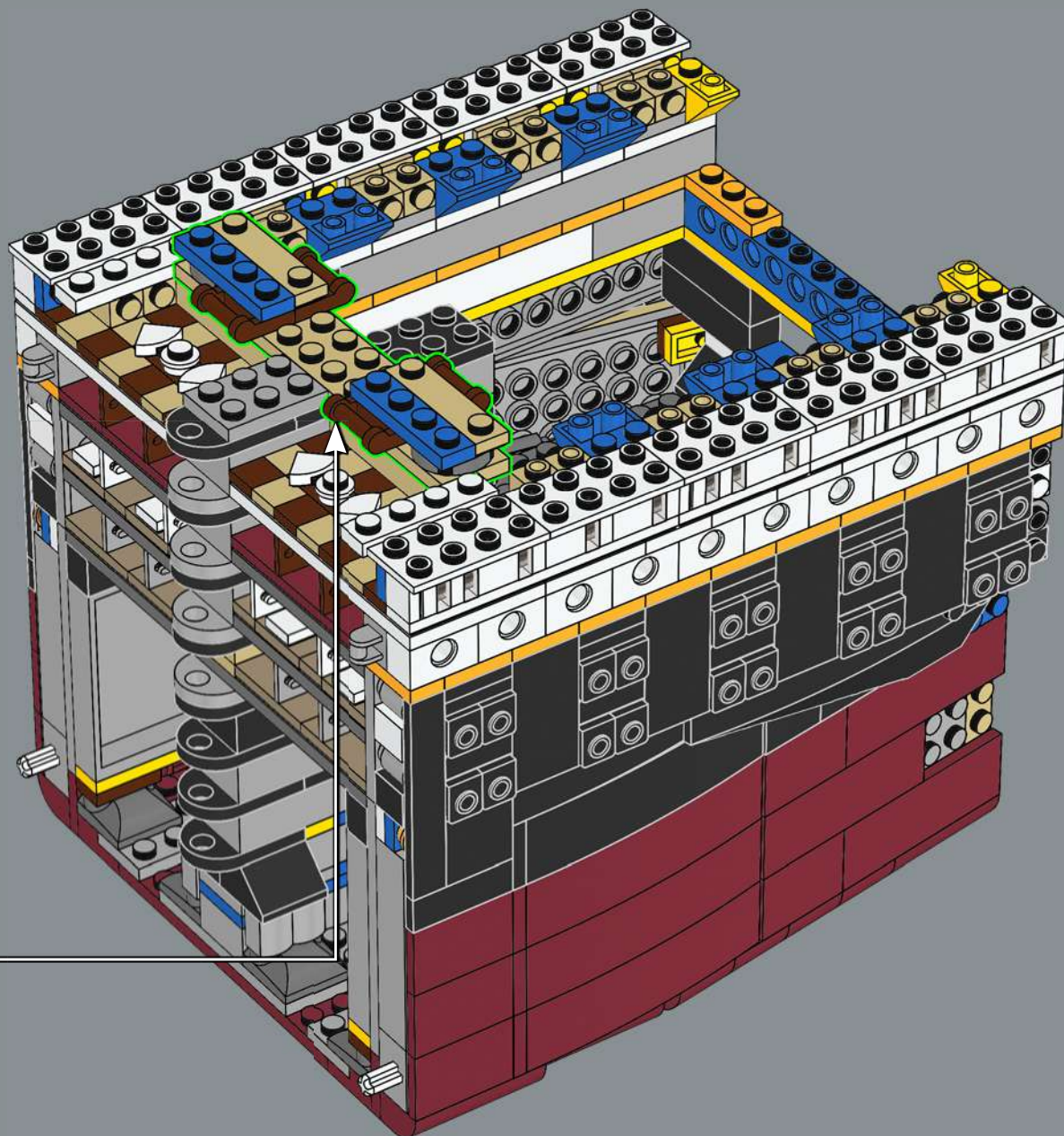
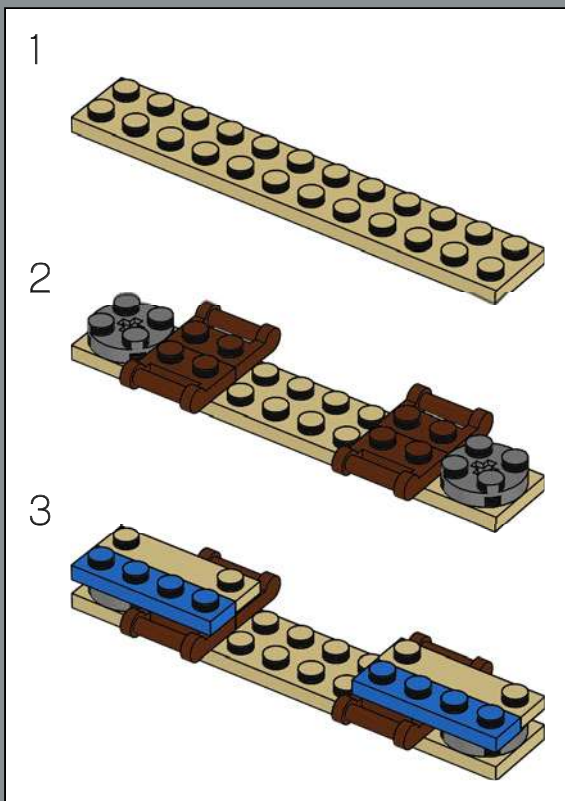

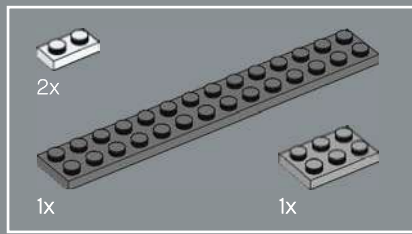

103

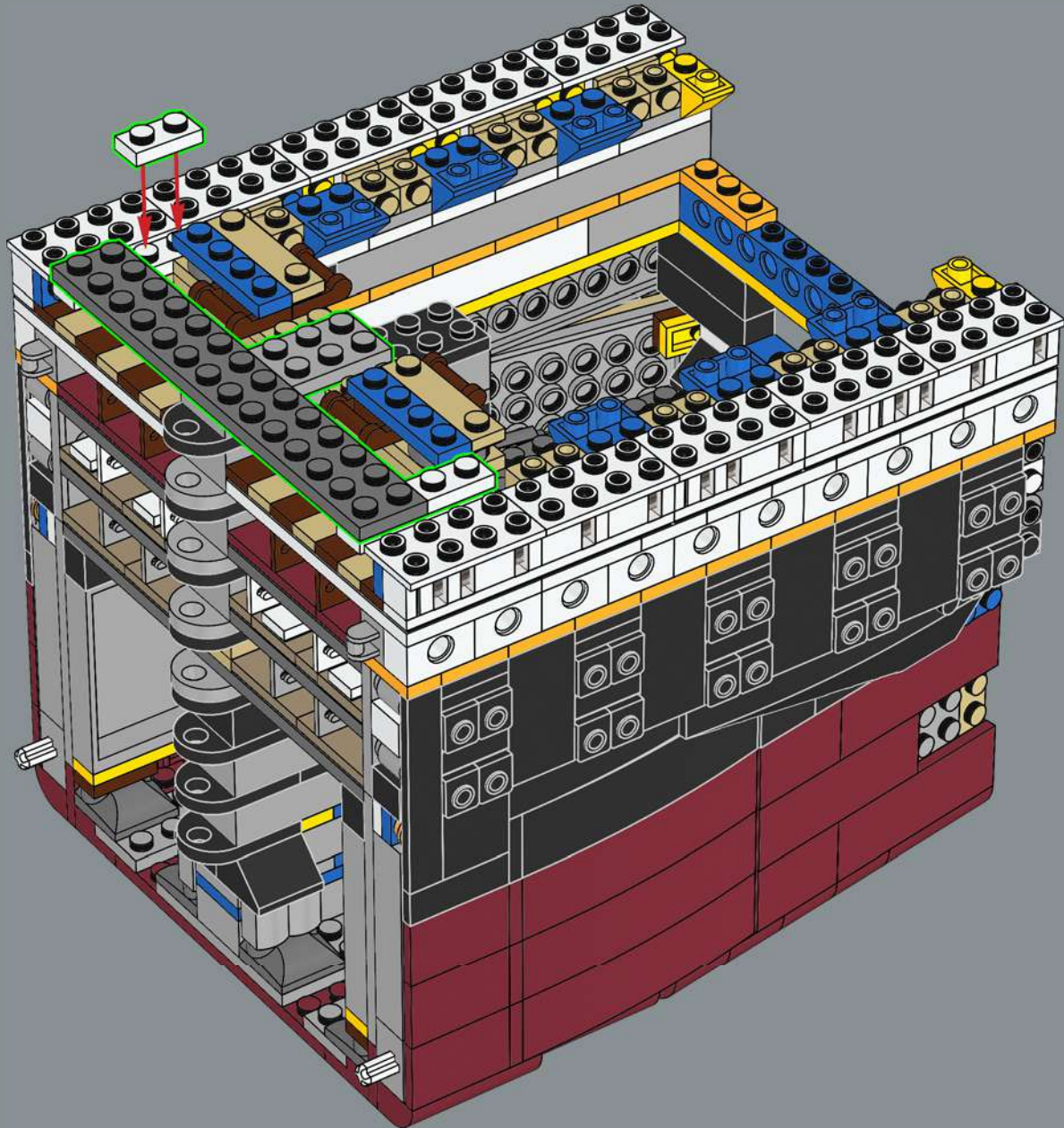

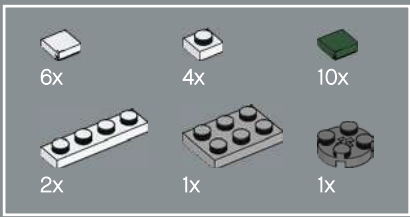

104

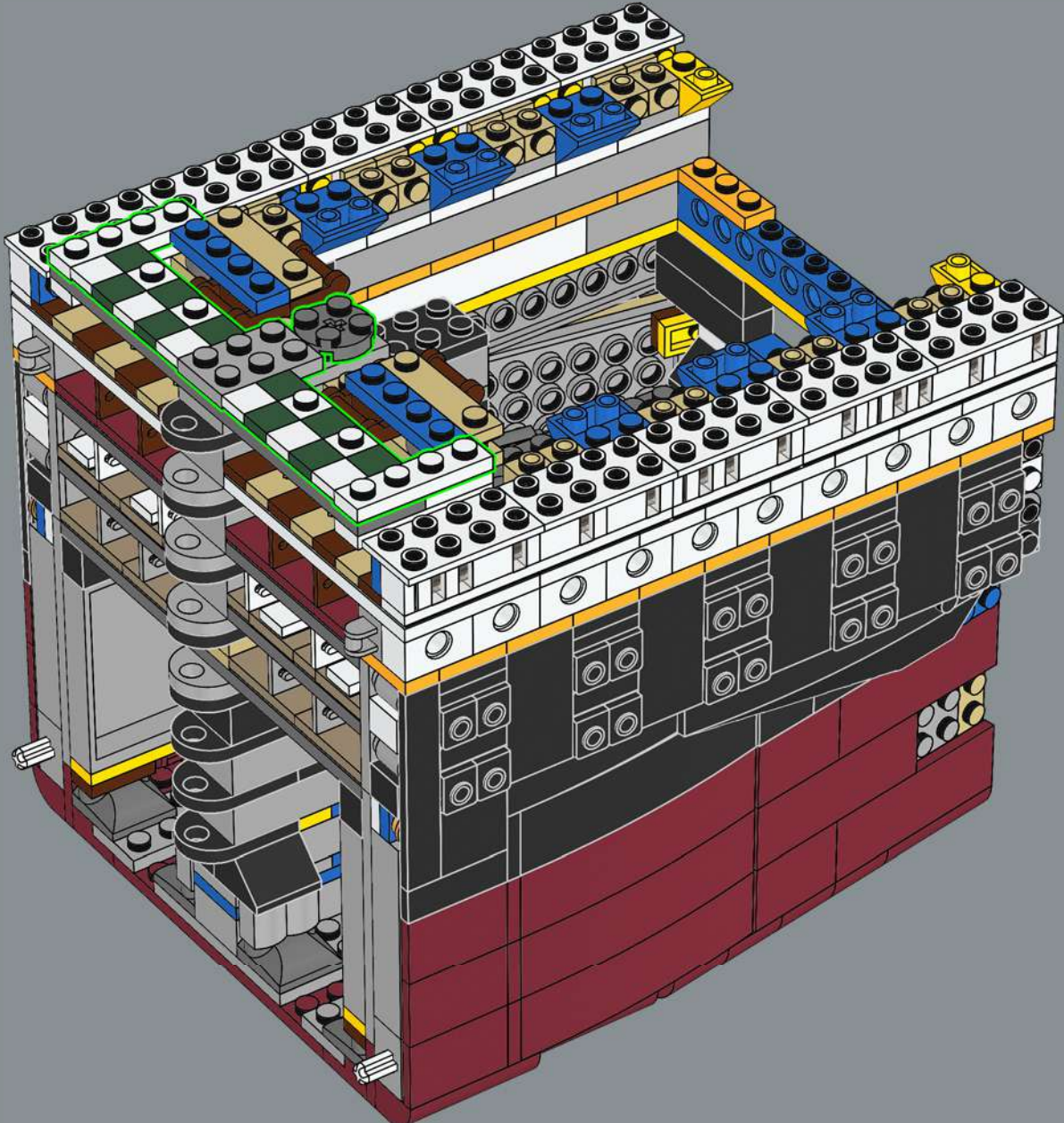

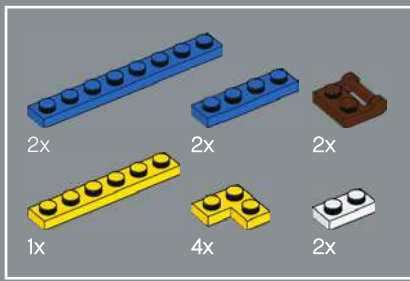

105

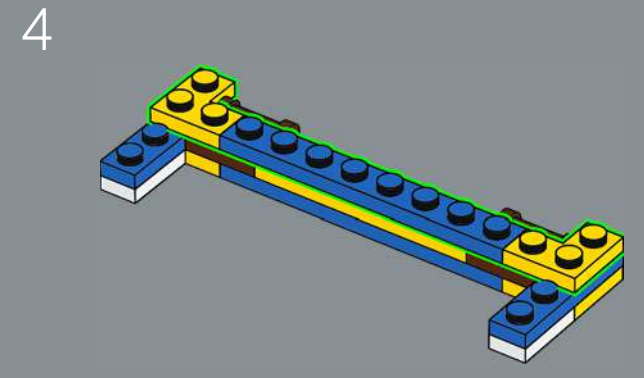
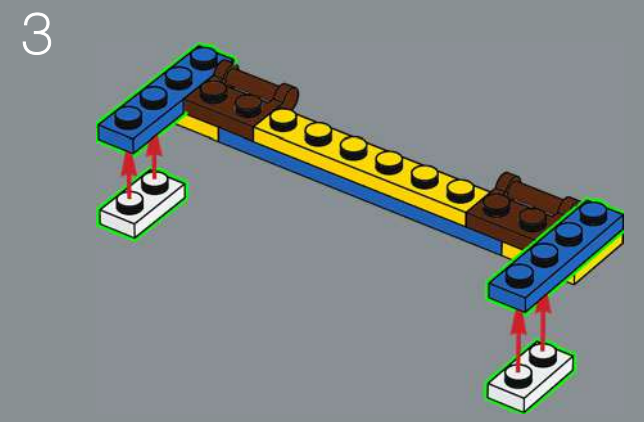
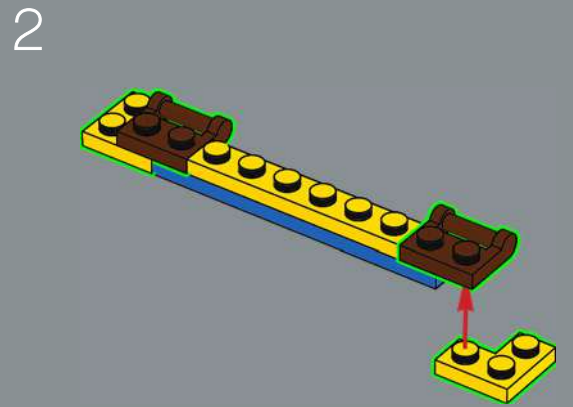
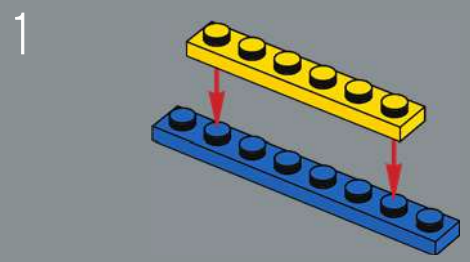

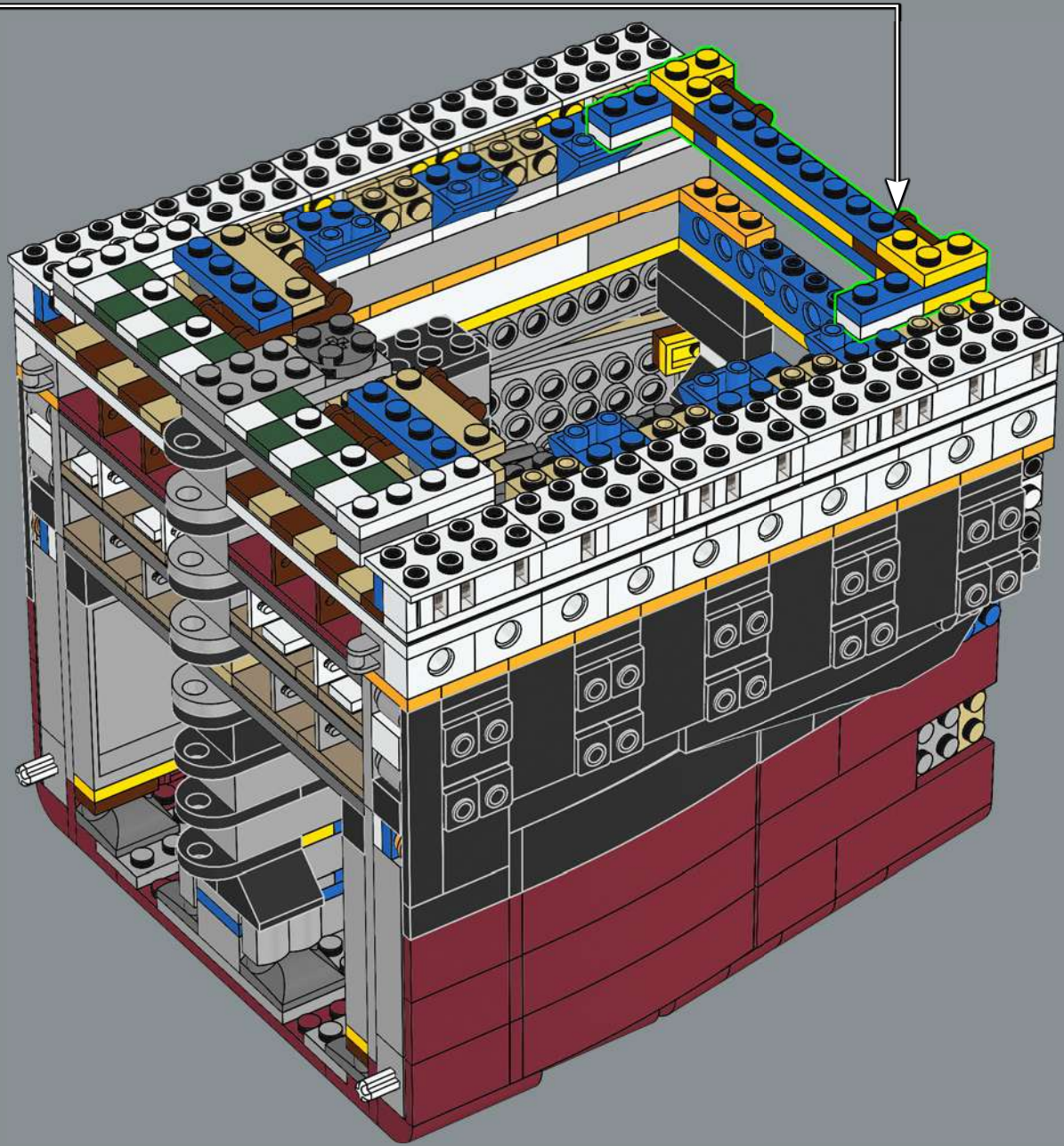

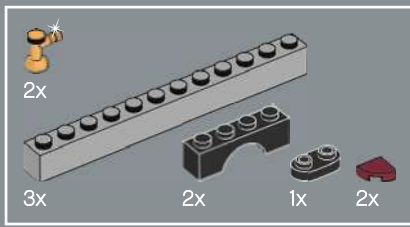

106

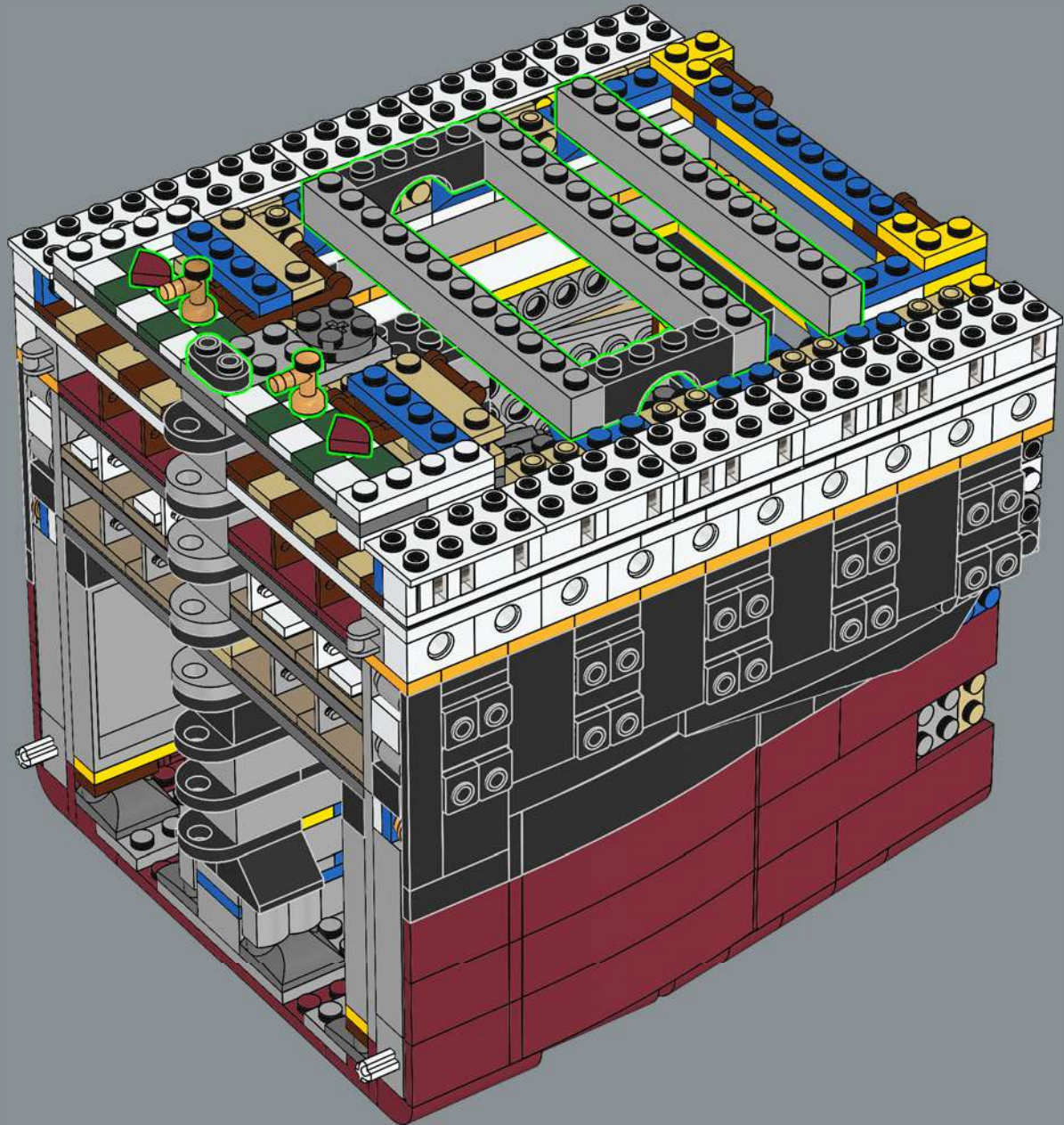

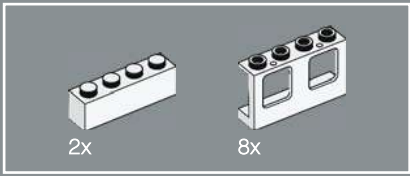

107

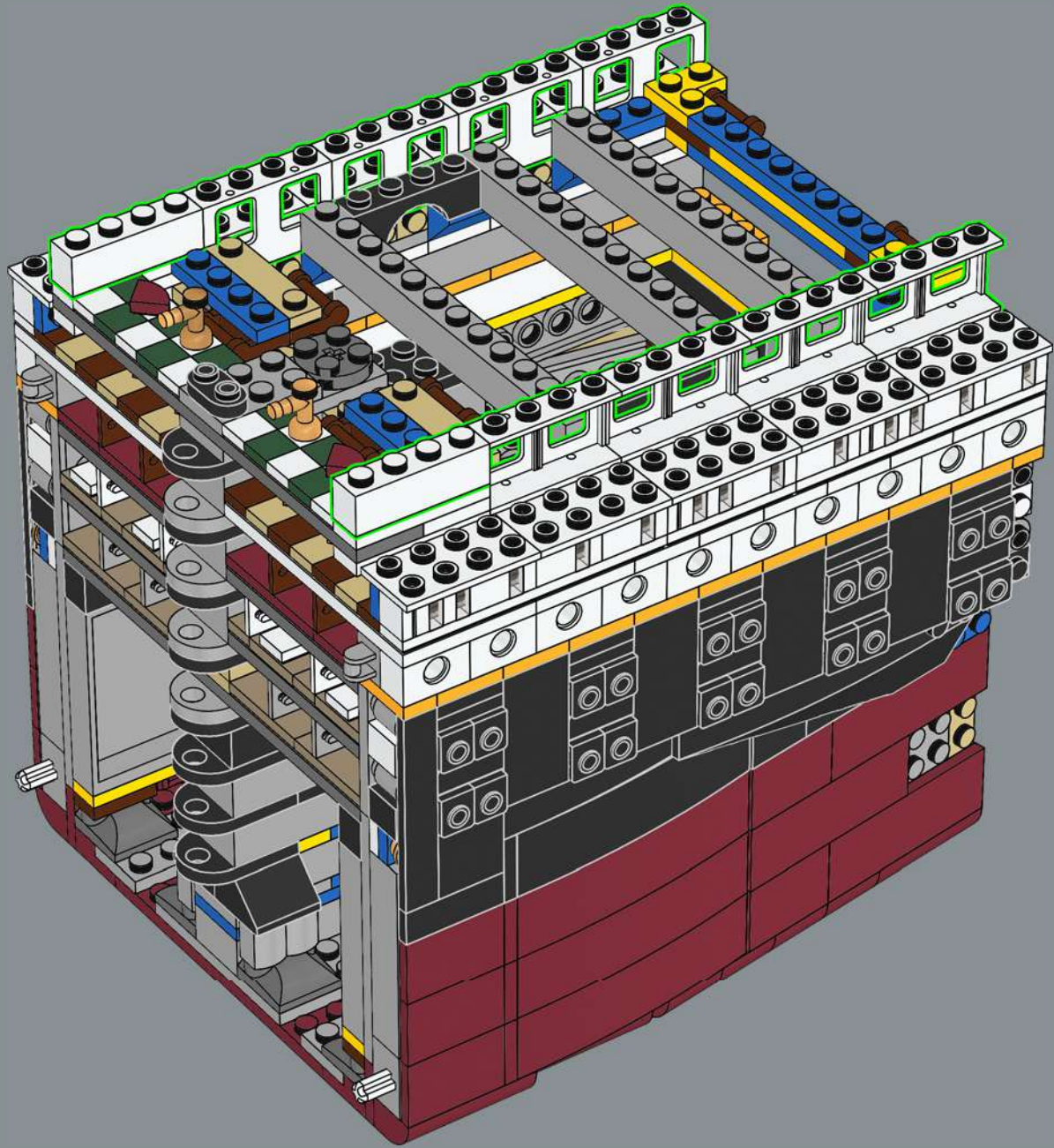

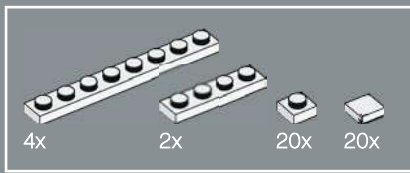

108

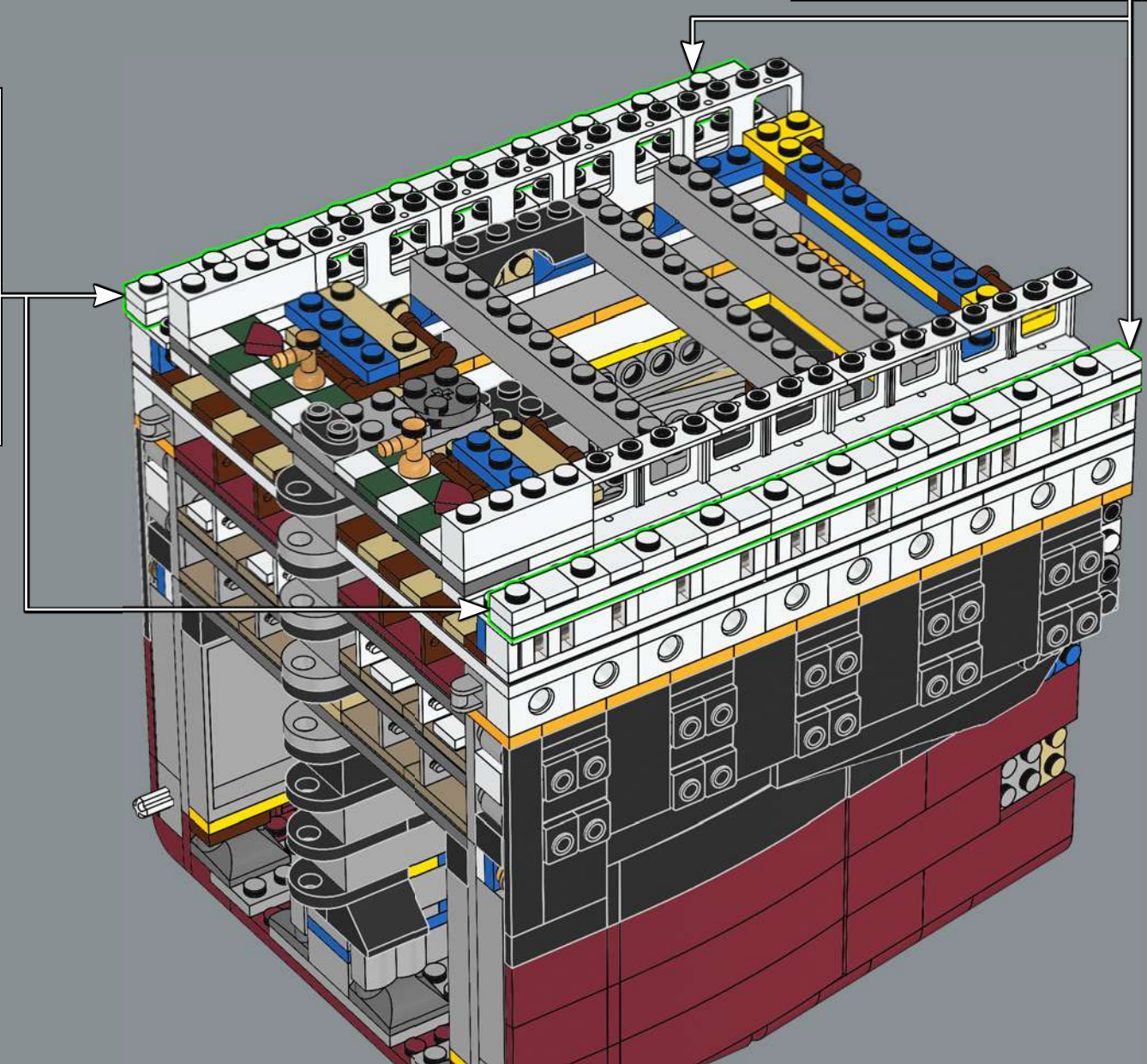
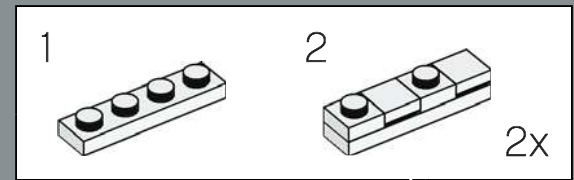
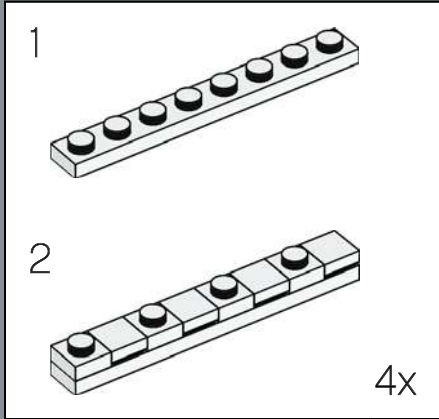



20x

109

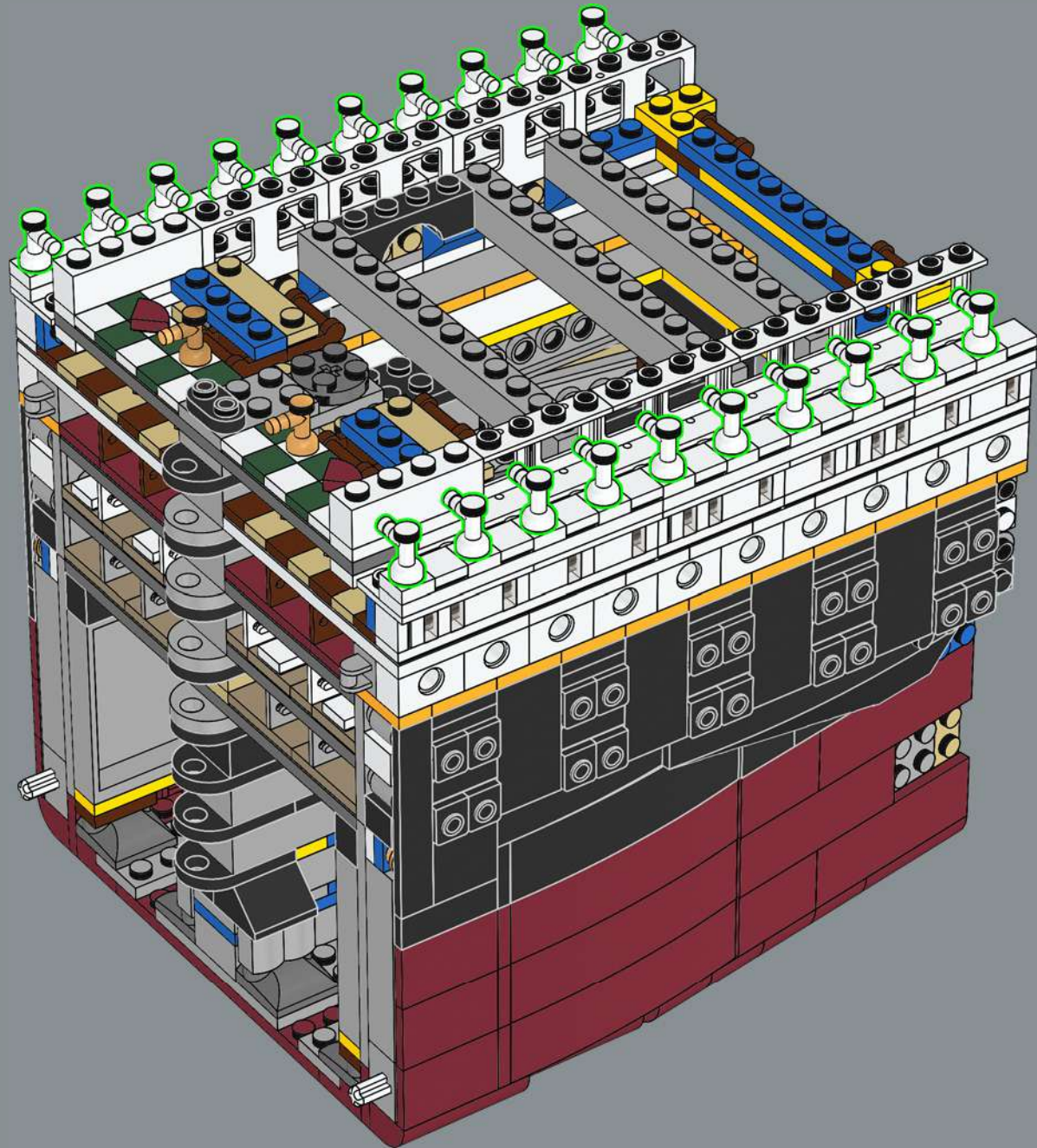

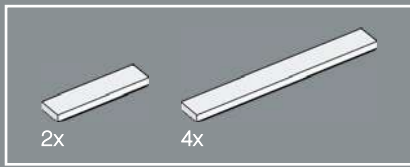

110

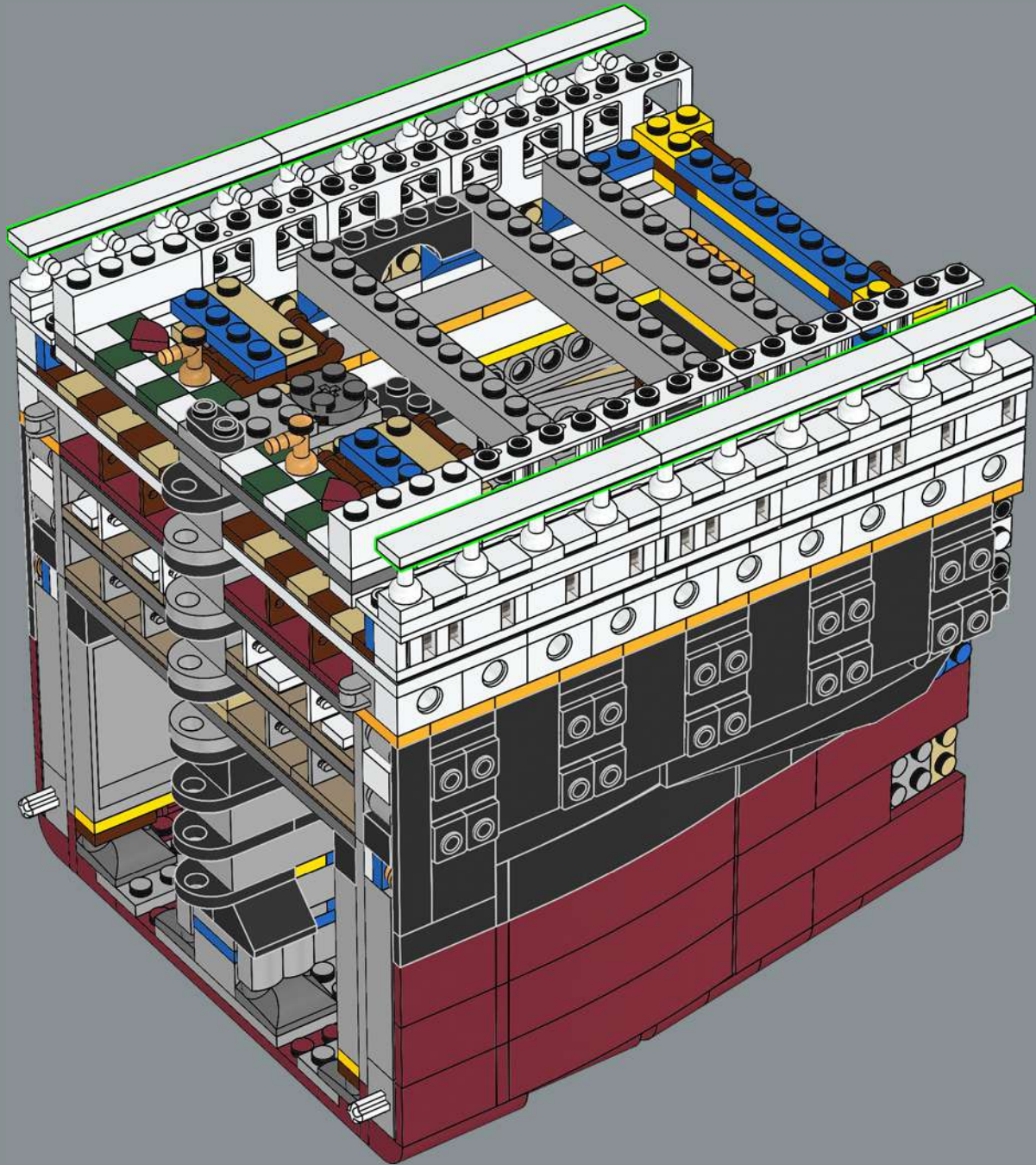

34

2x

4x

2x

111

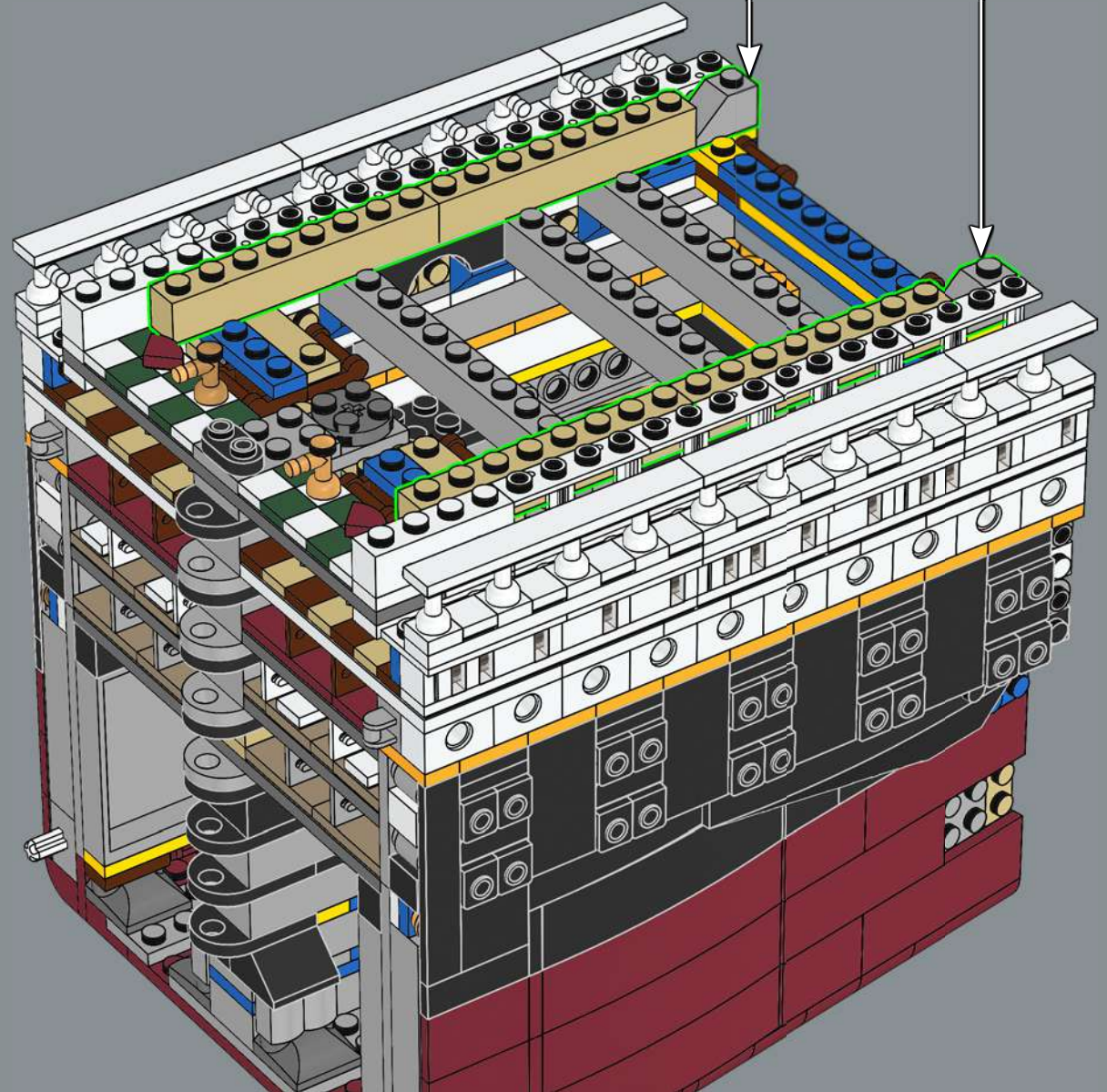

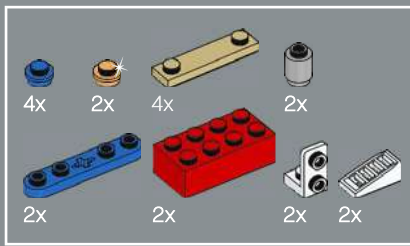

112

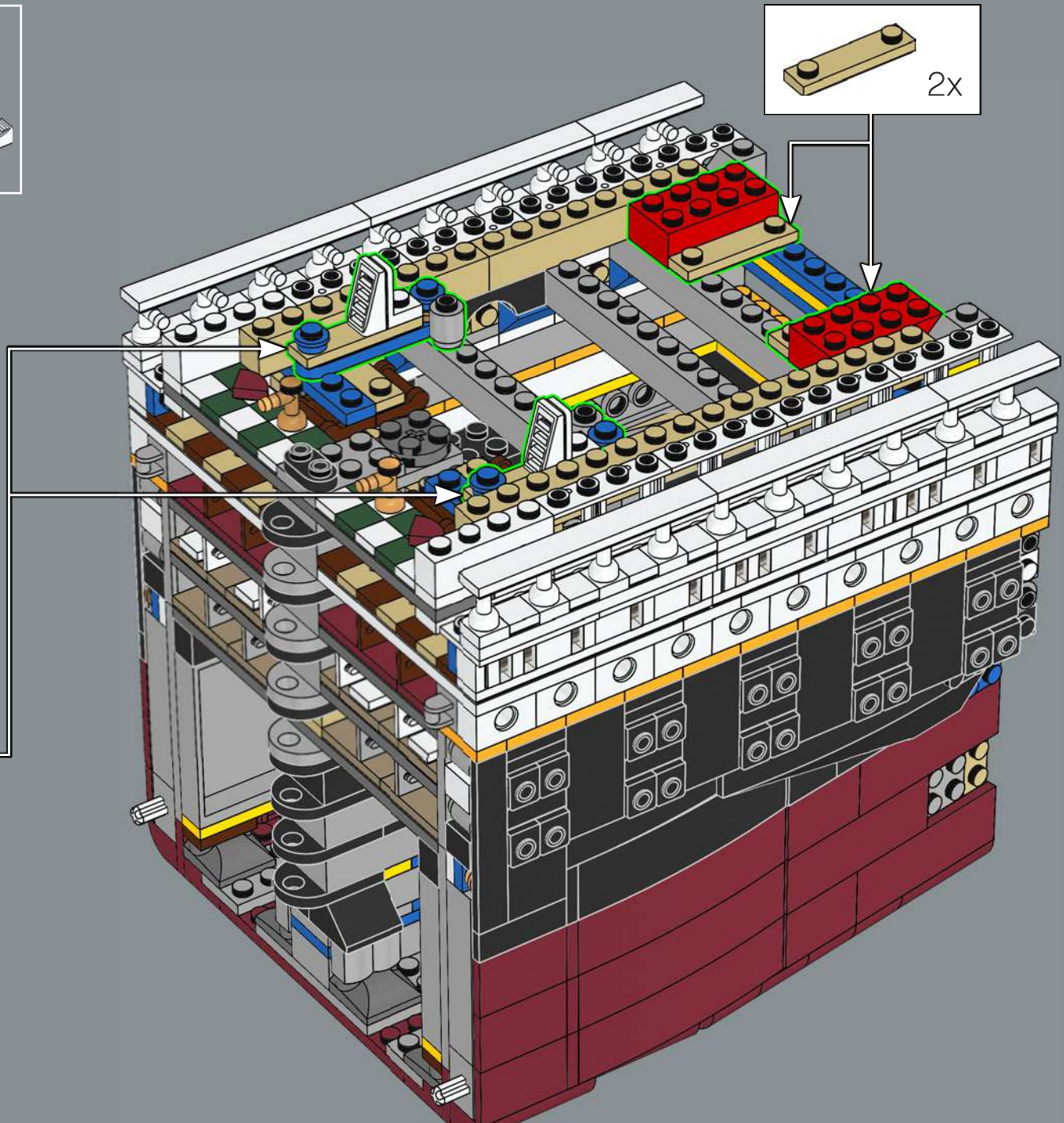
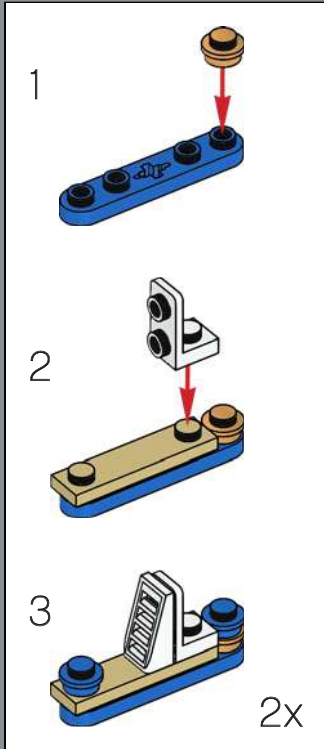

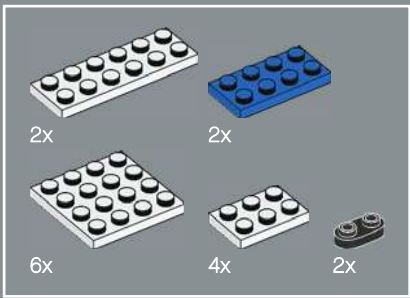

113

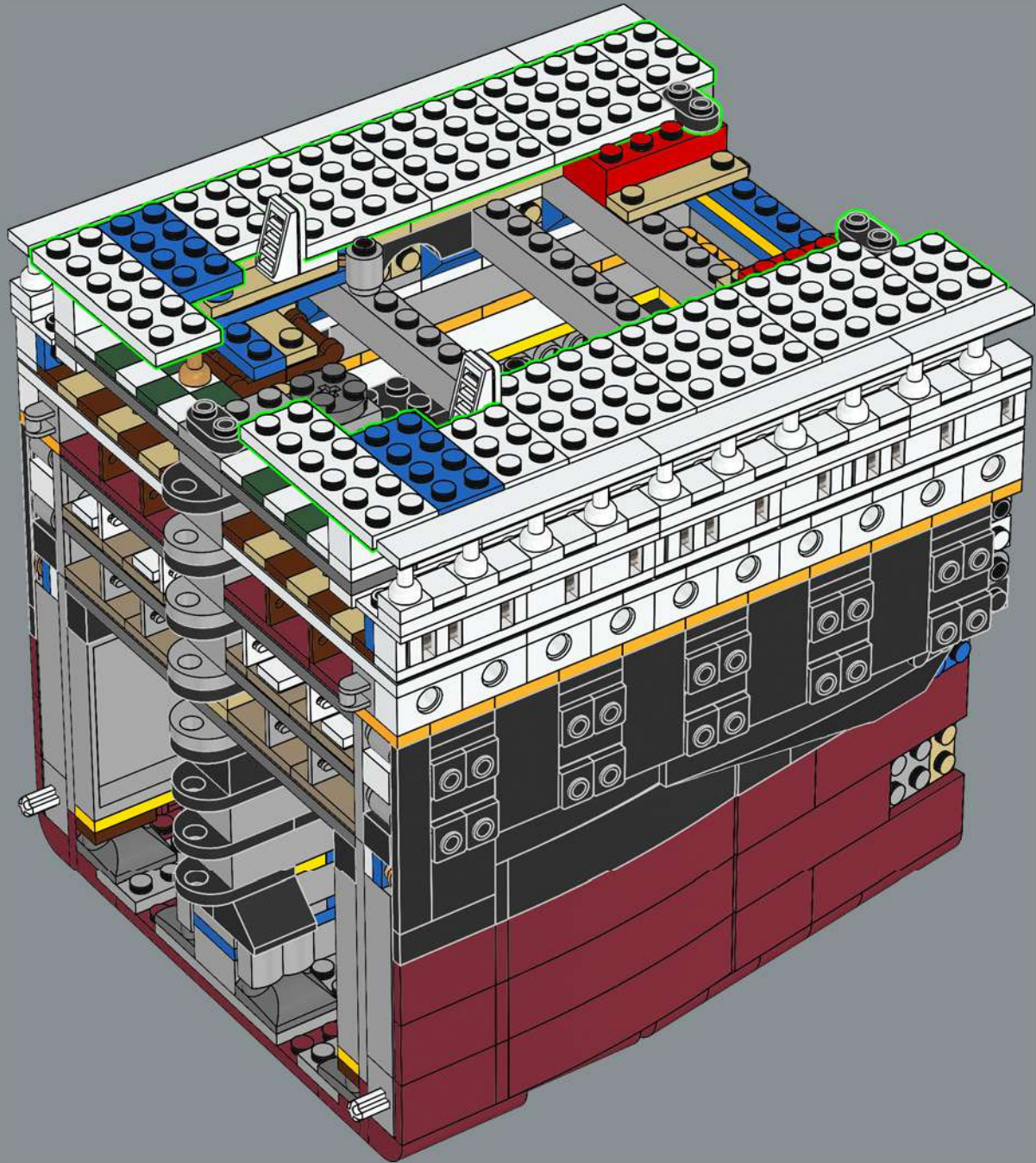

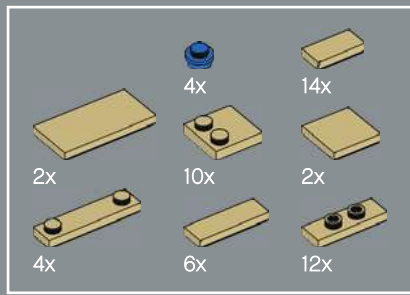

114

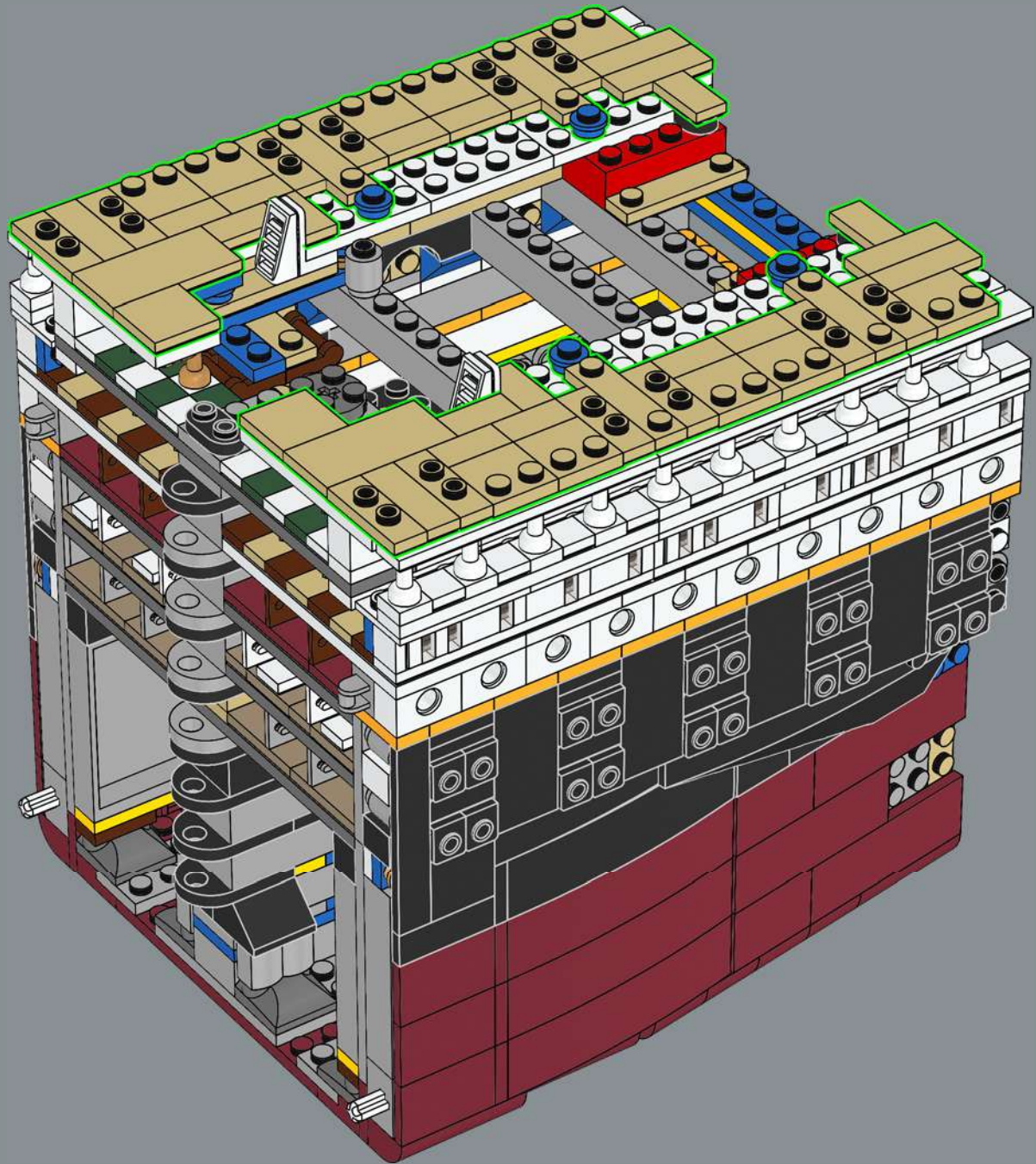

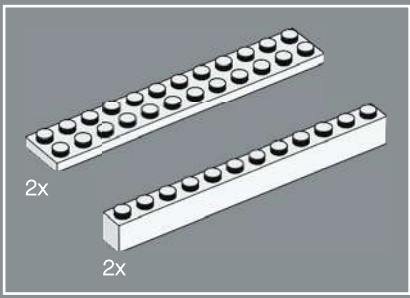

115

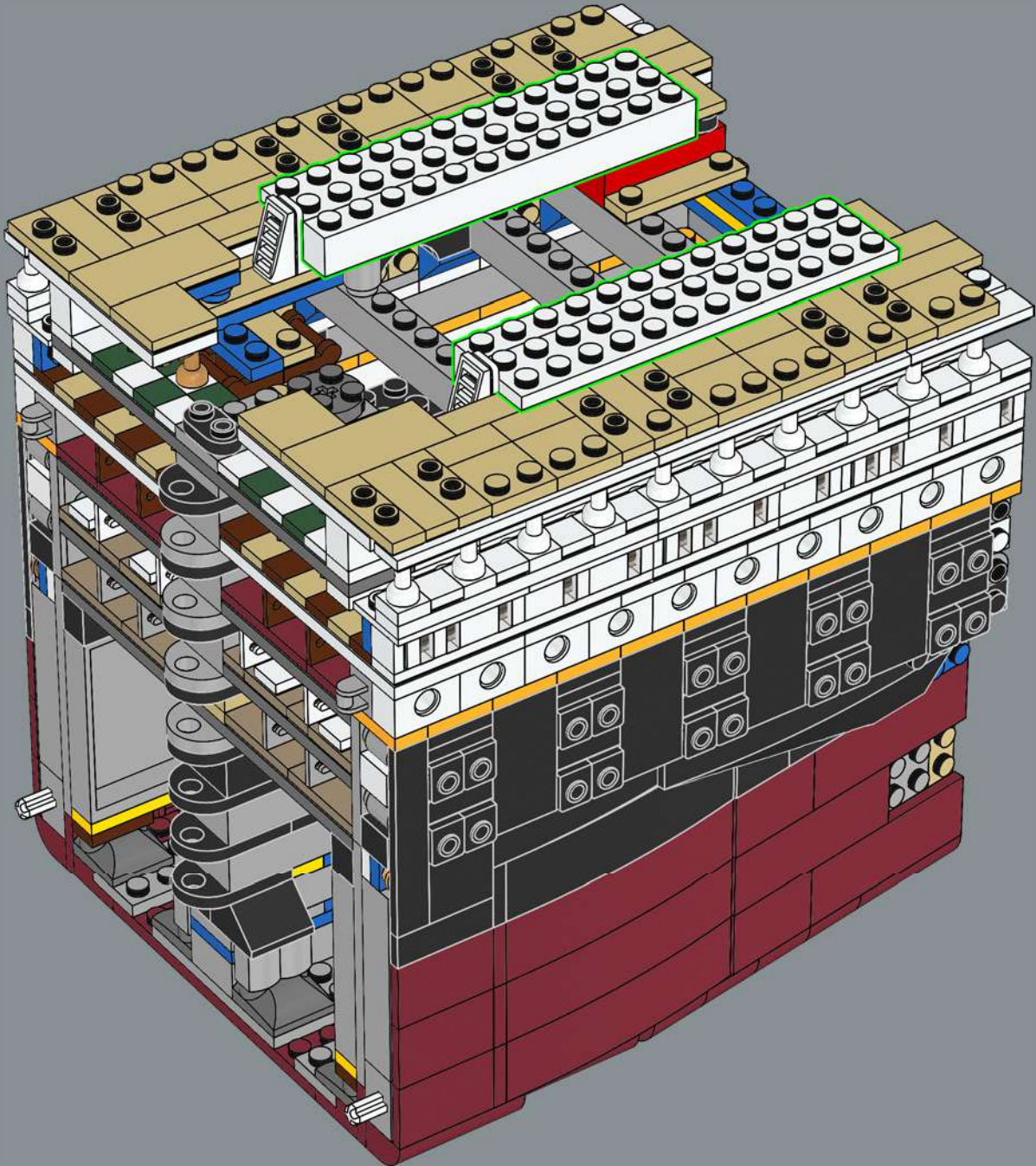

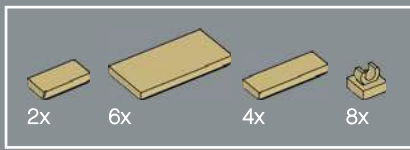

116

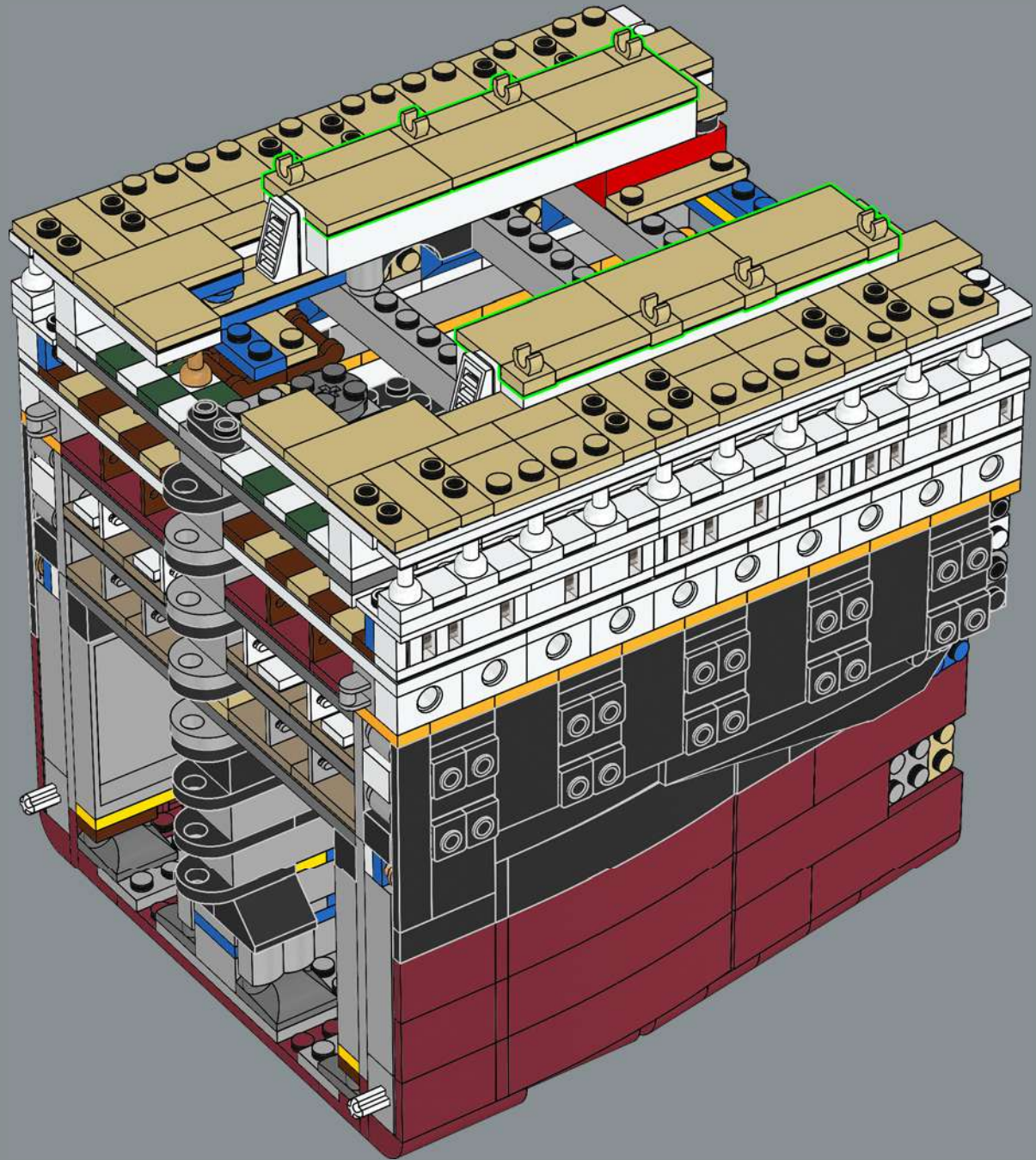

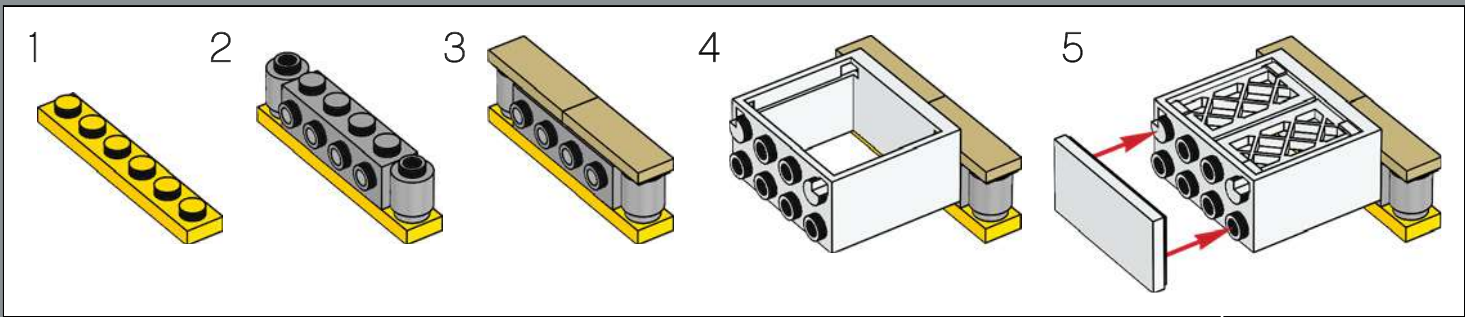
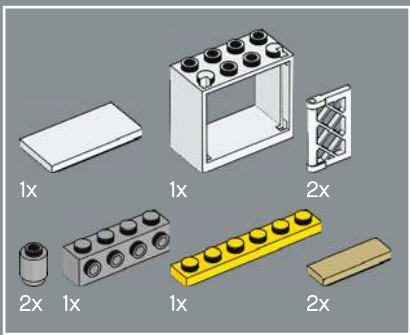

117

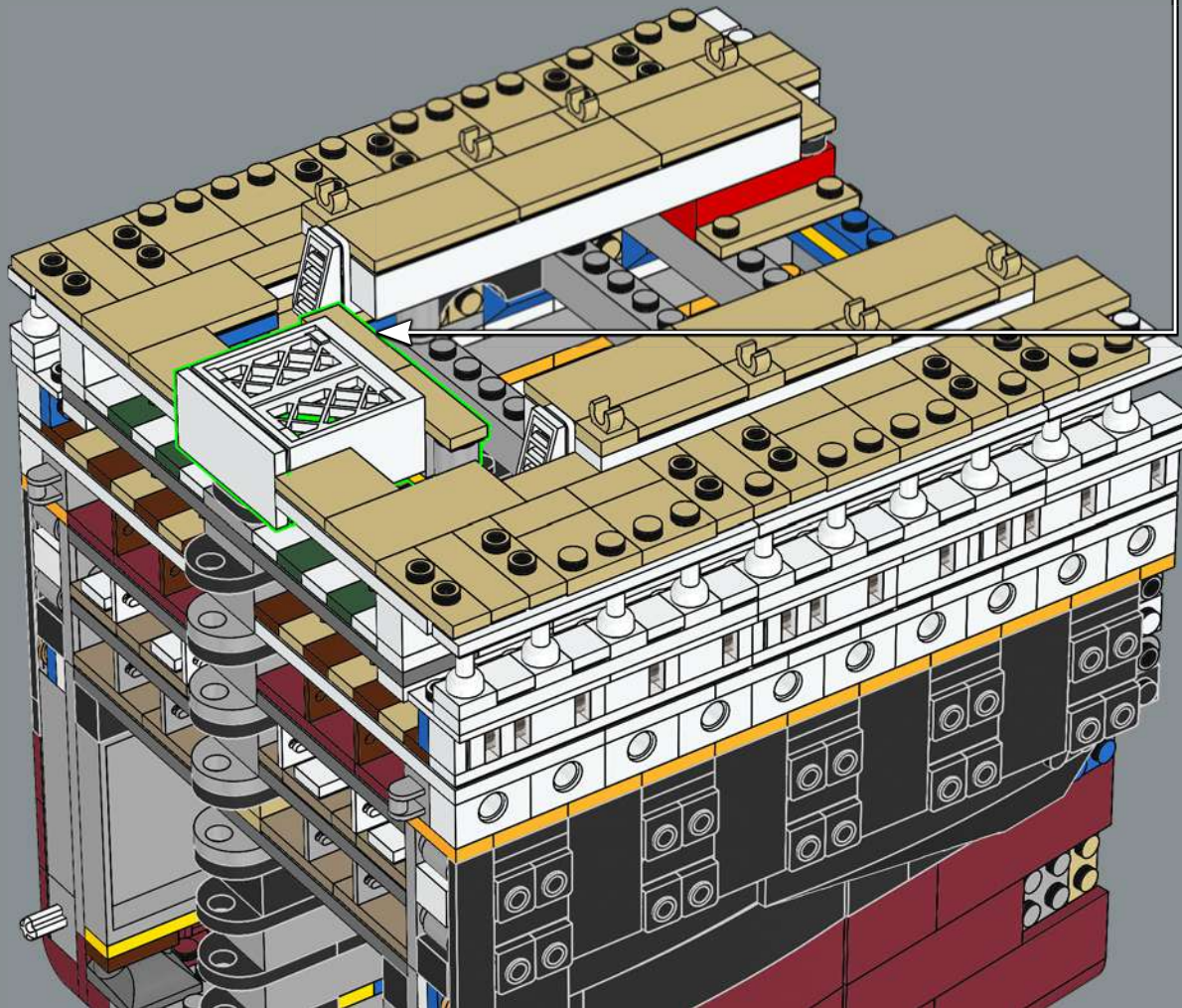

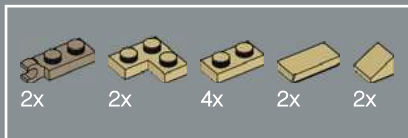

118

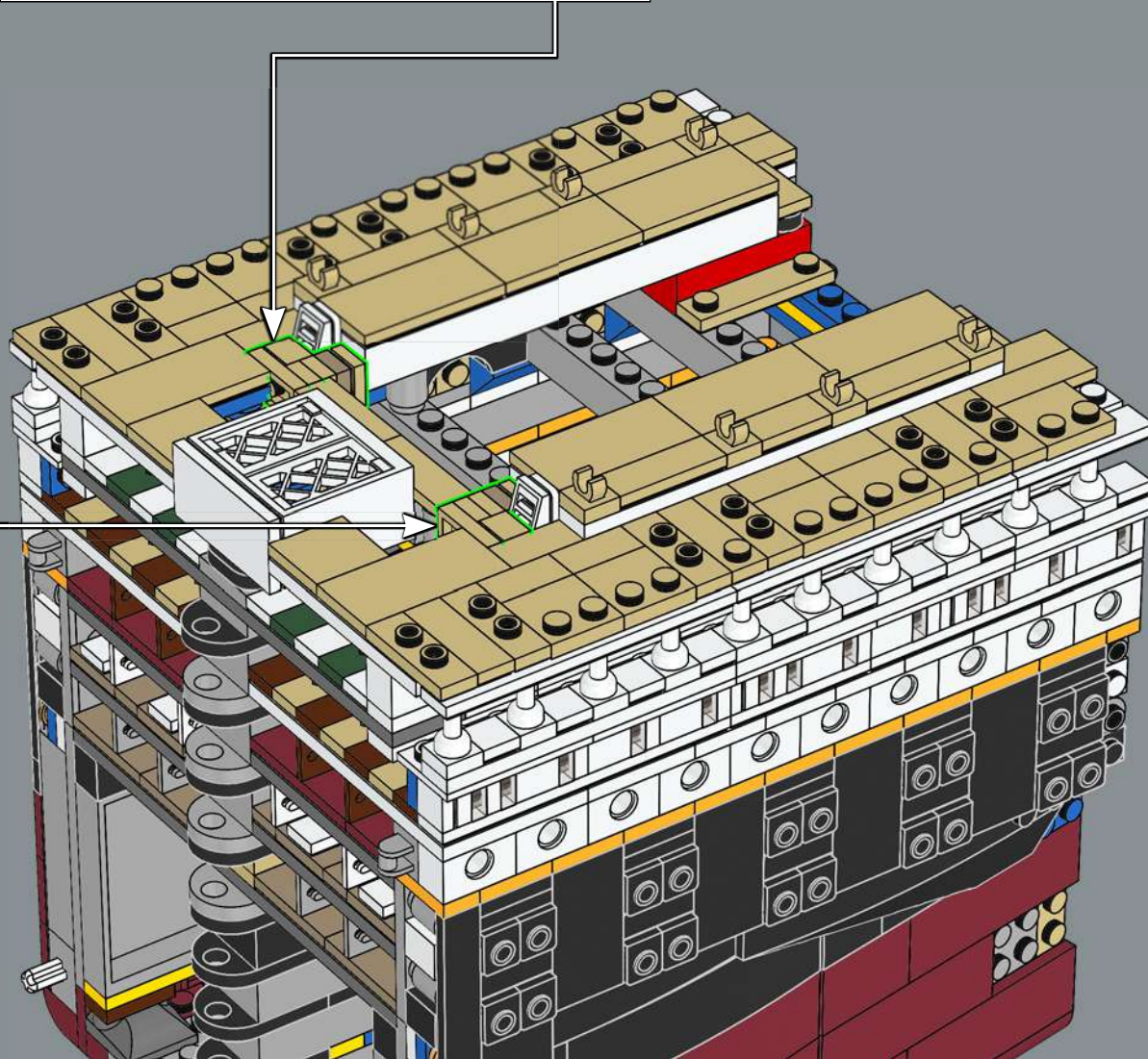
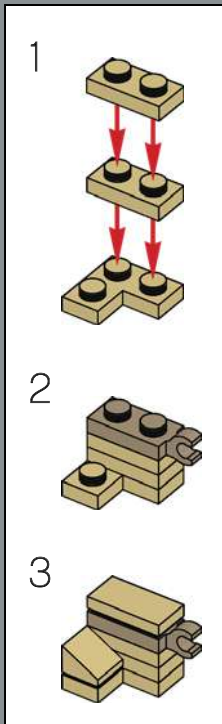
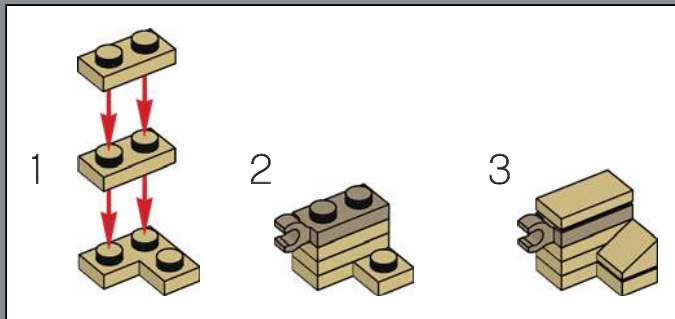

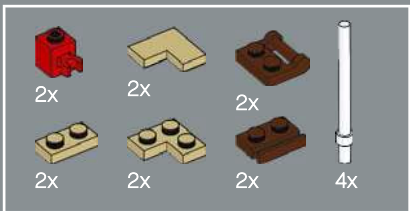

119

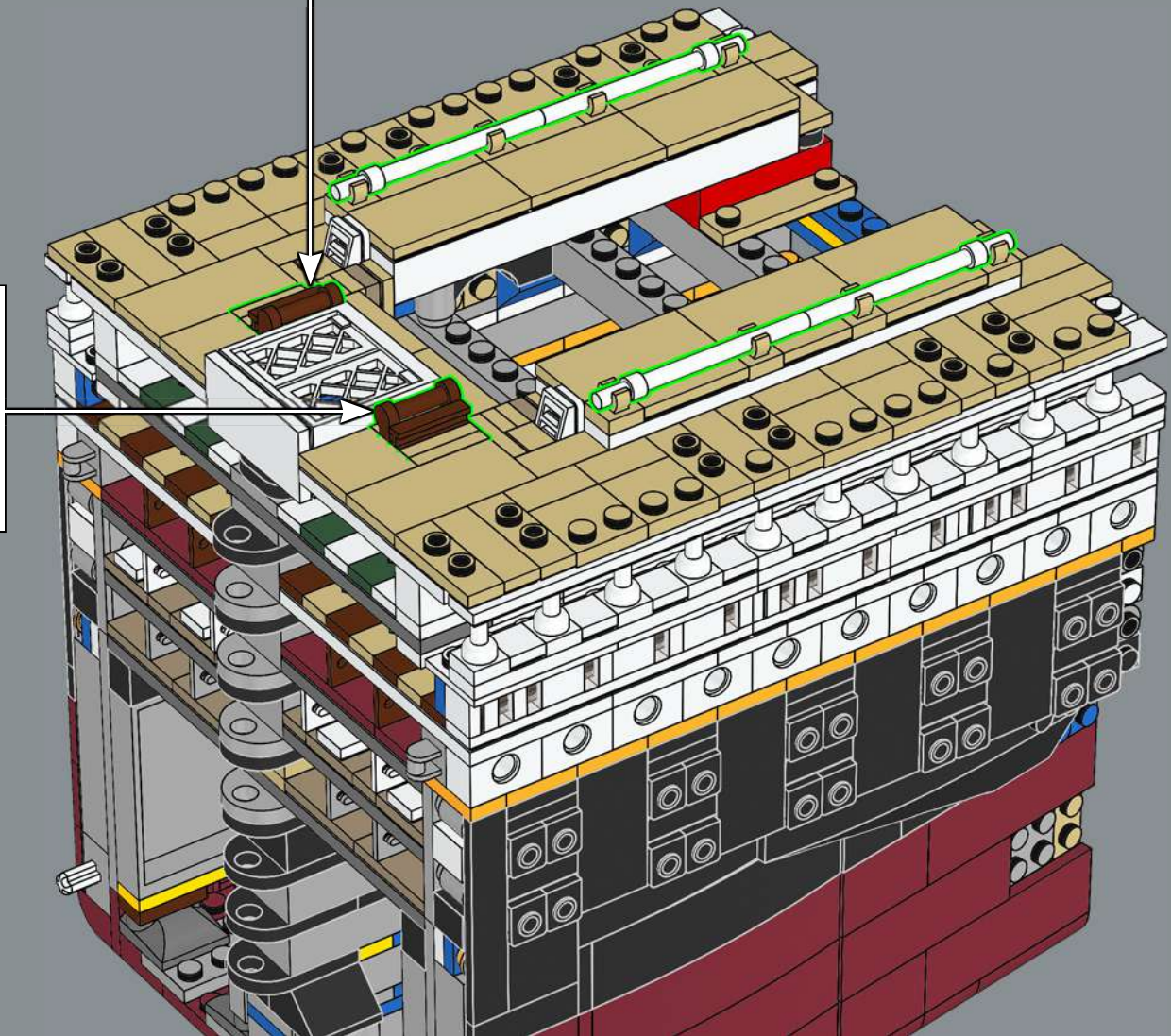
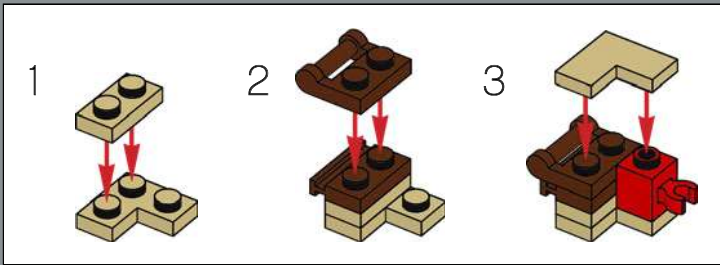
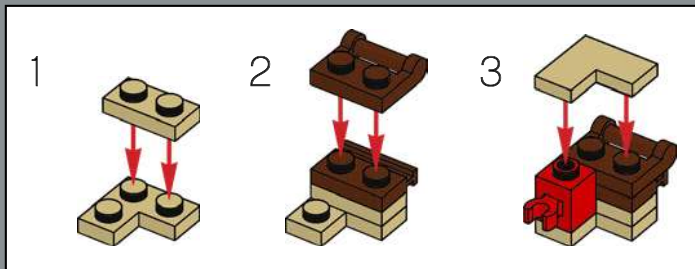

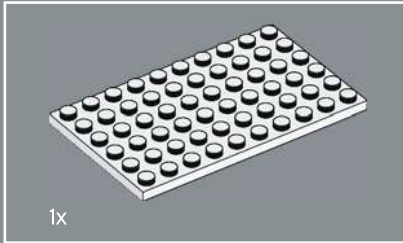
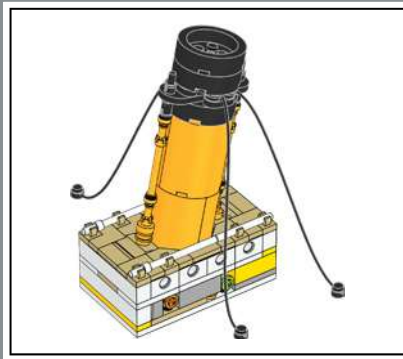
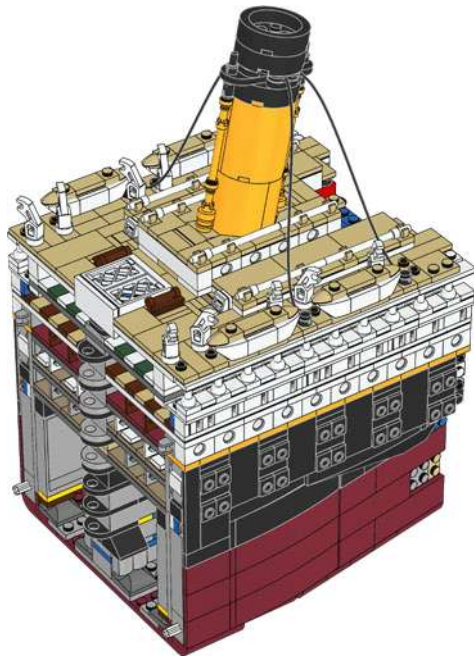

120

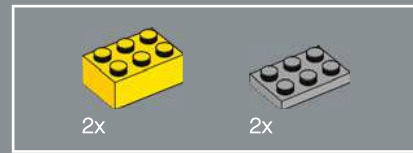
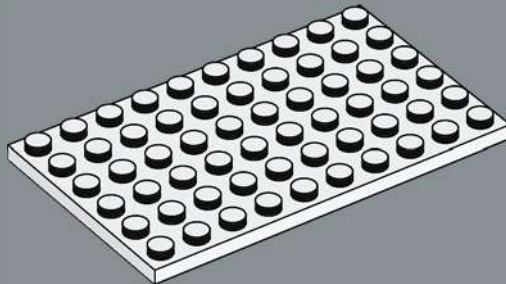

121

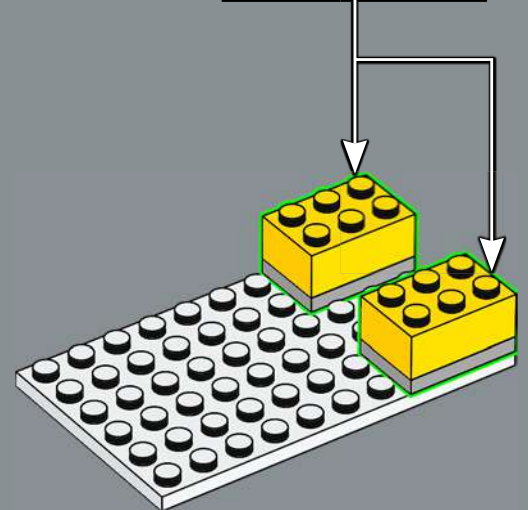
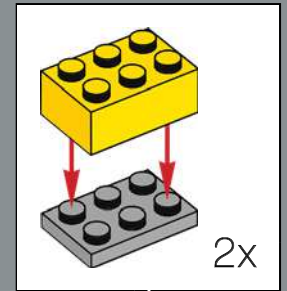

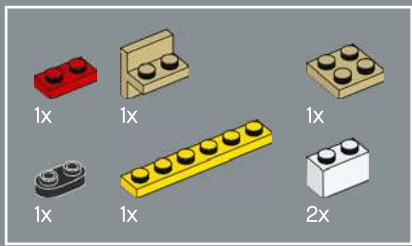

122

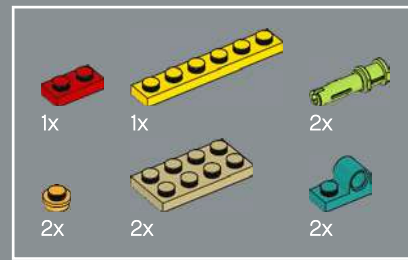
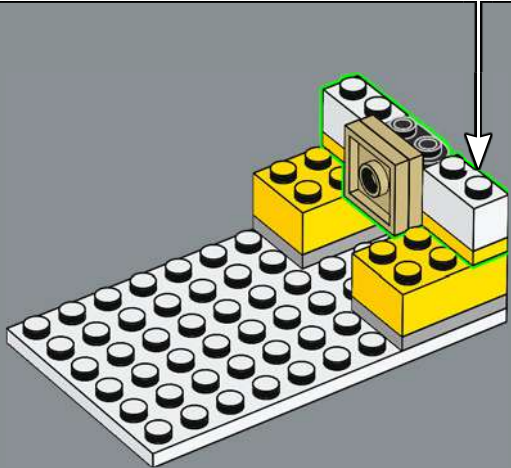
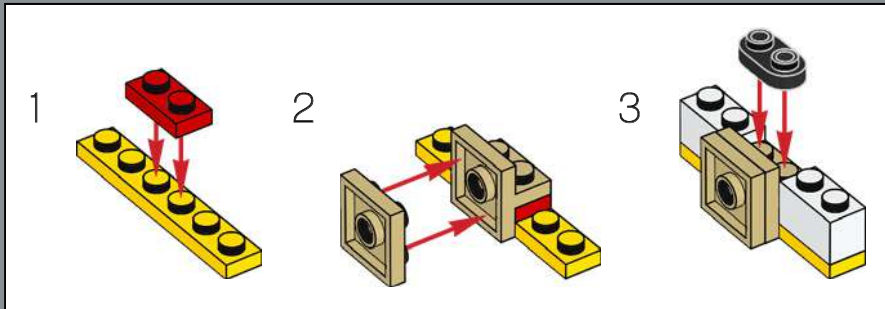

123

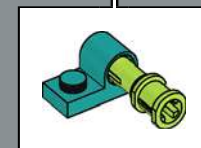
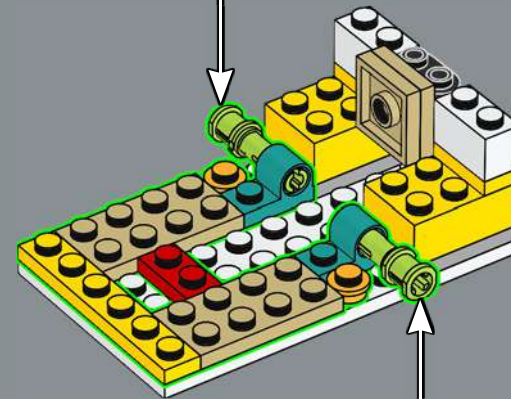
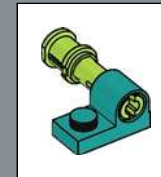

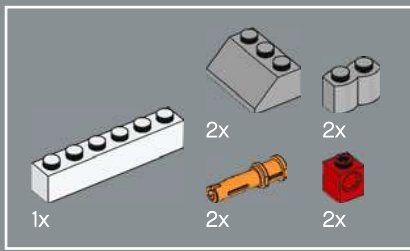

124

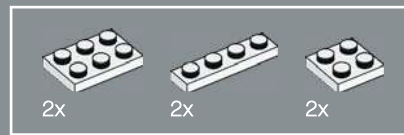
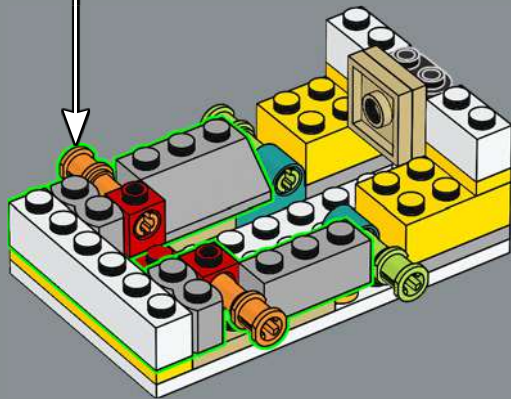

125

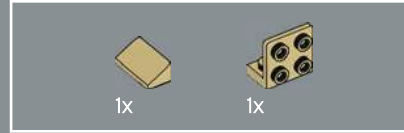
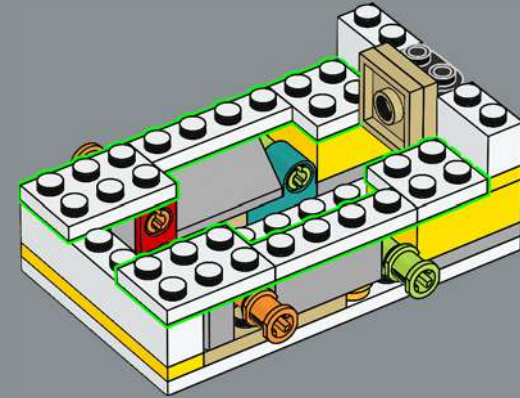

126

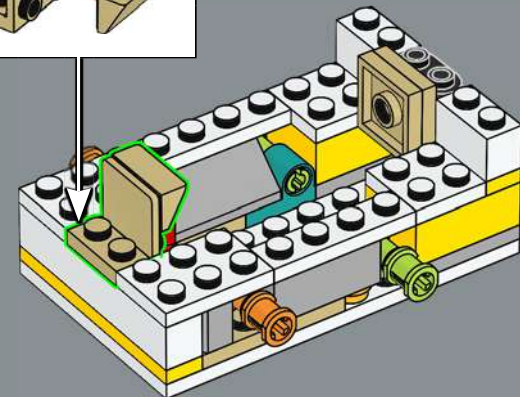
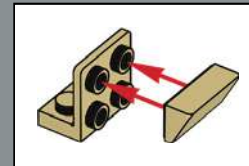

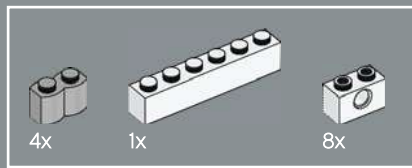

127

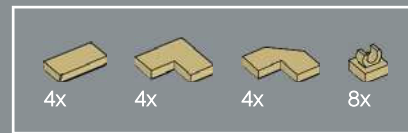
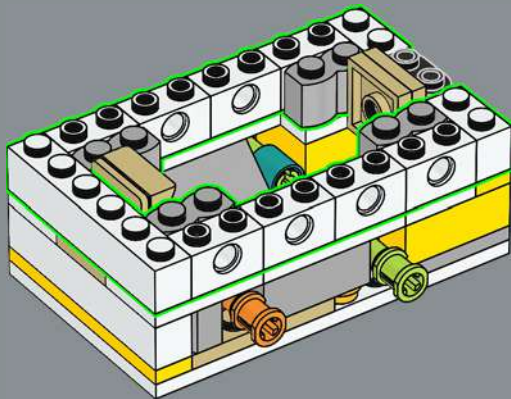

128

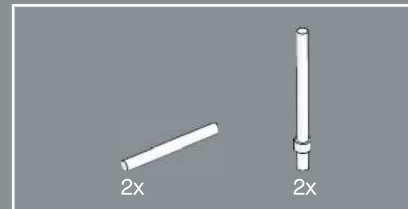
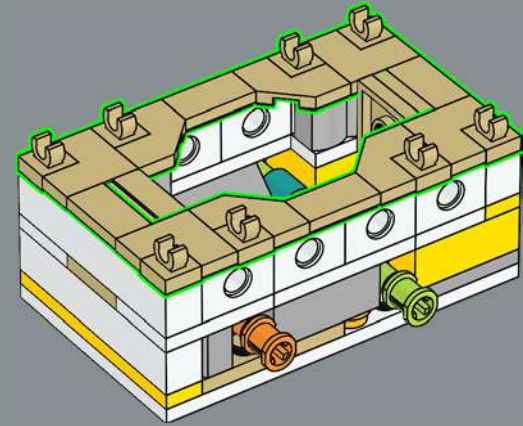

129

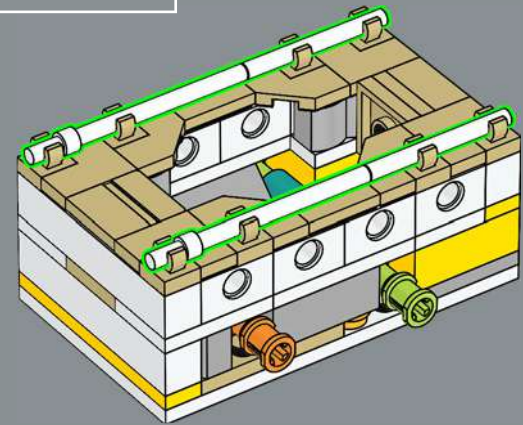

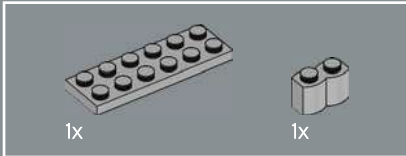
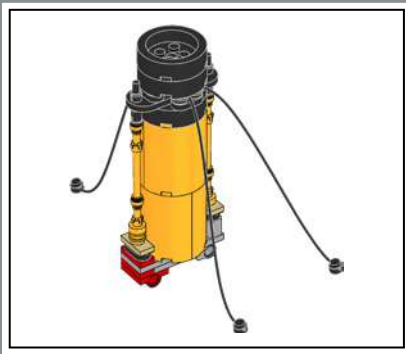

130

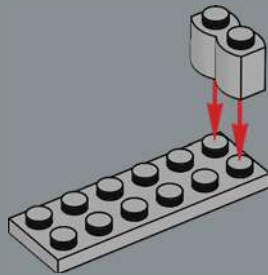

131

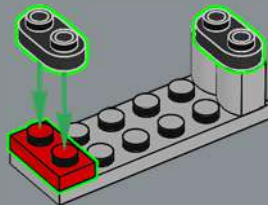

132

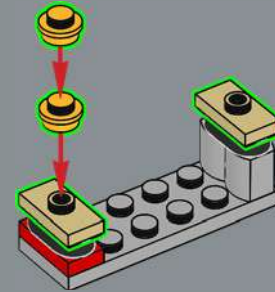

133

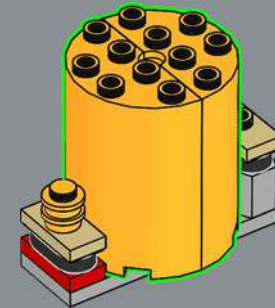

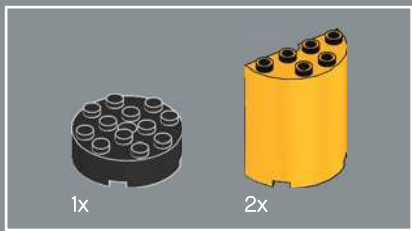

134

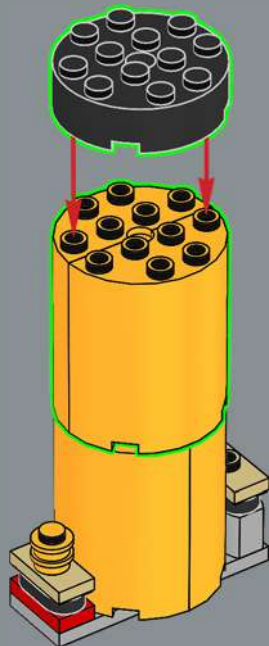

135

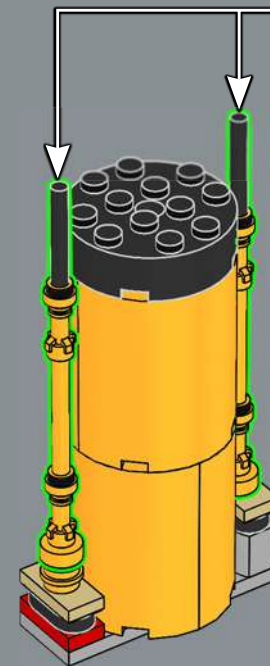
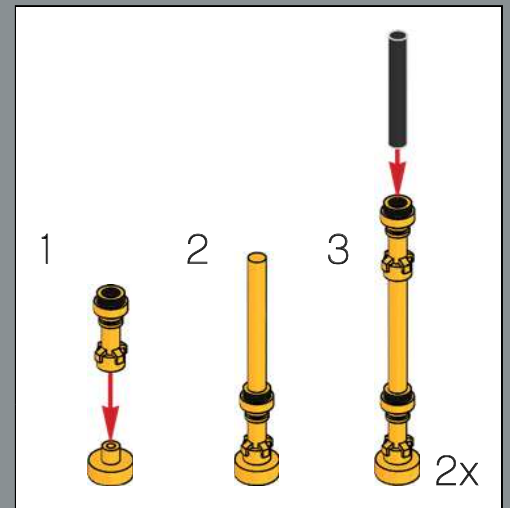



136

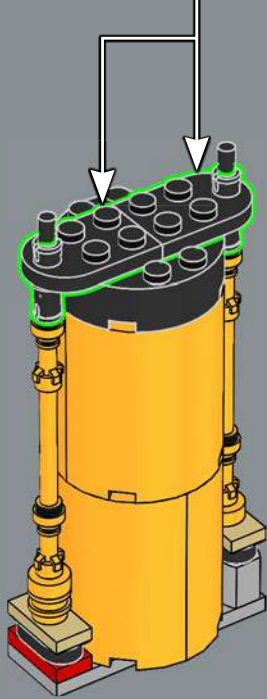
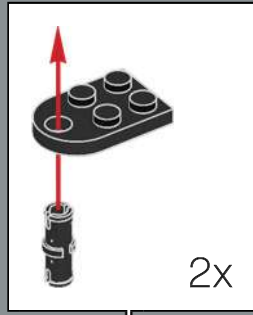

137

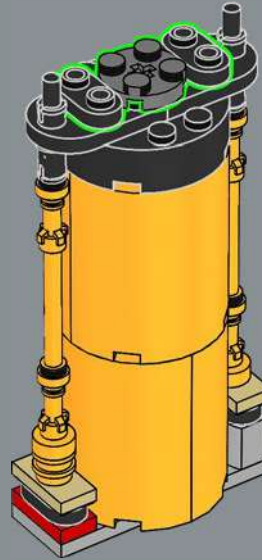

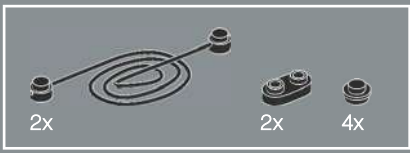

138

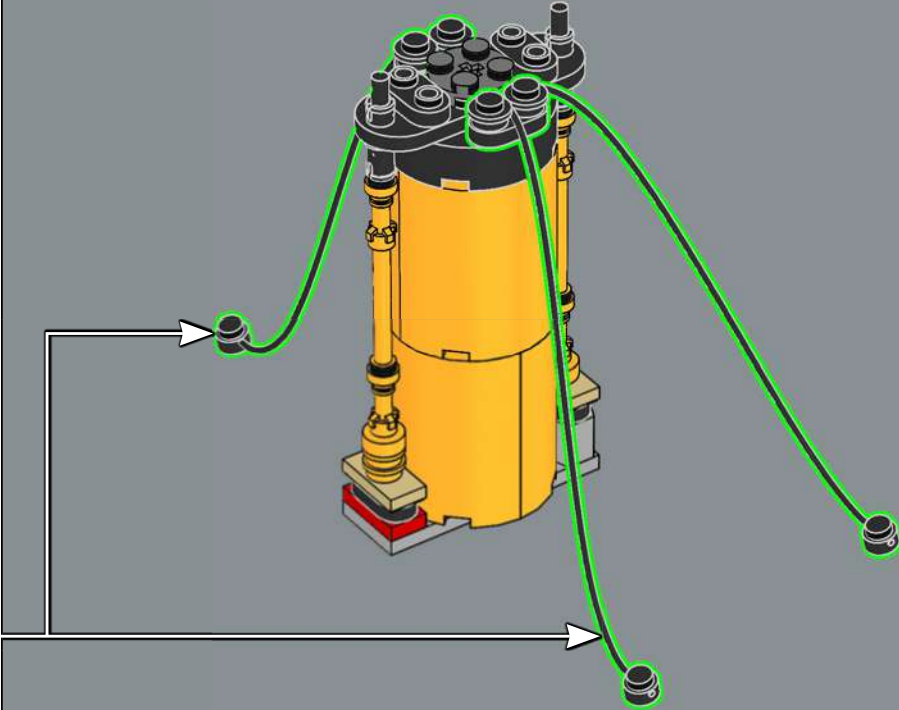
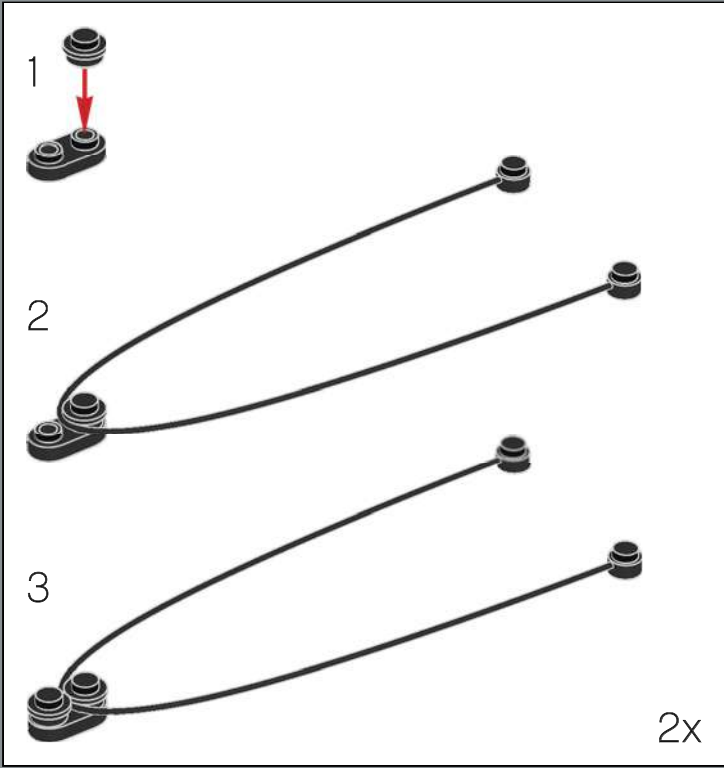

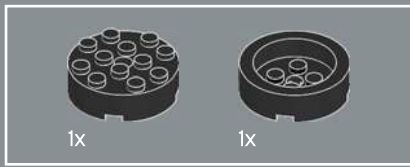

139

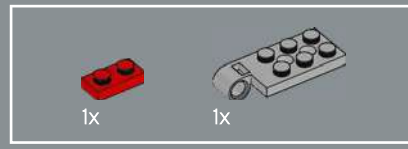
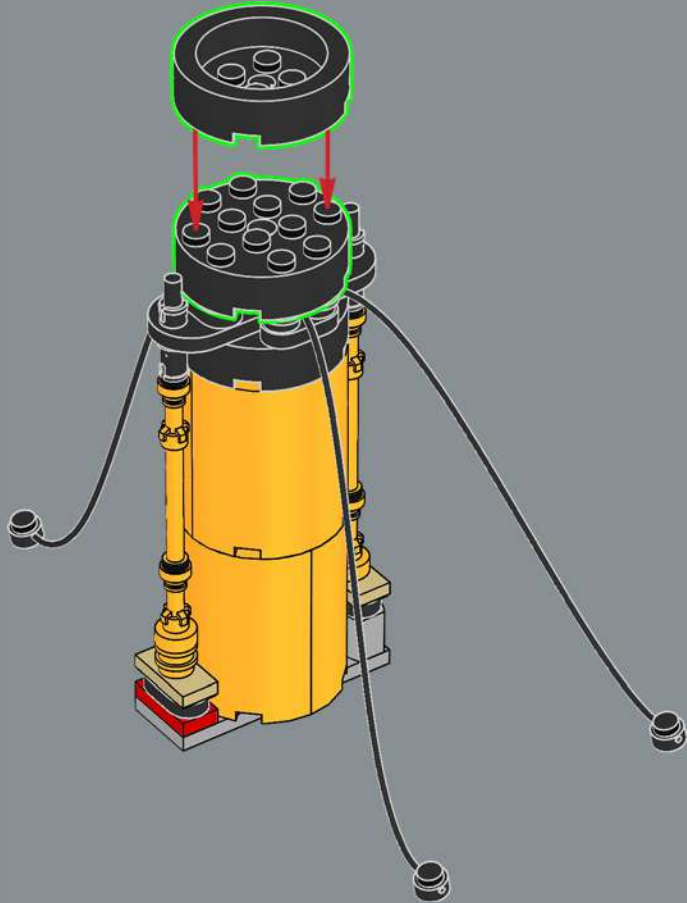

140

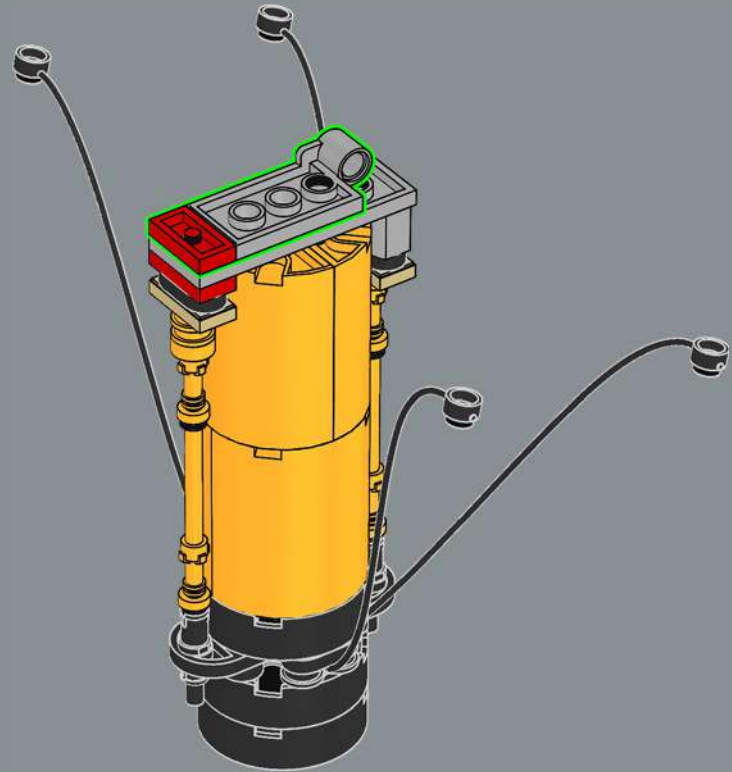

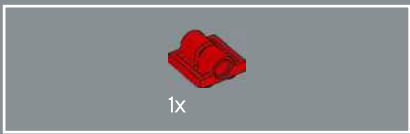

141

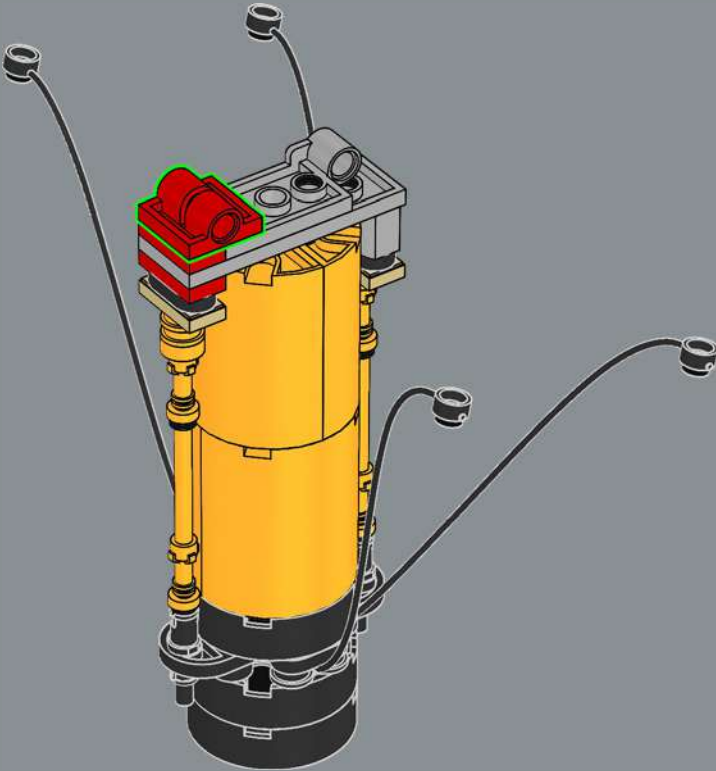

142

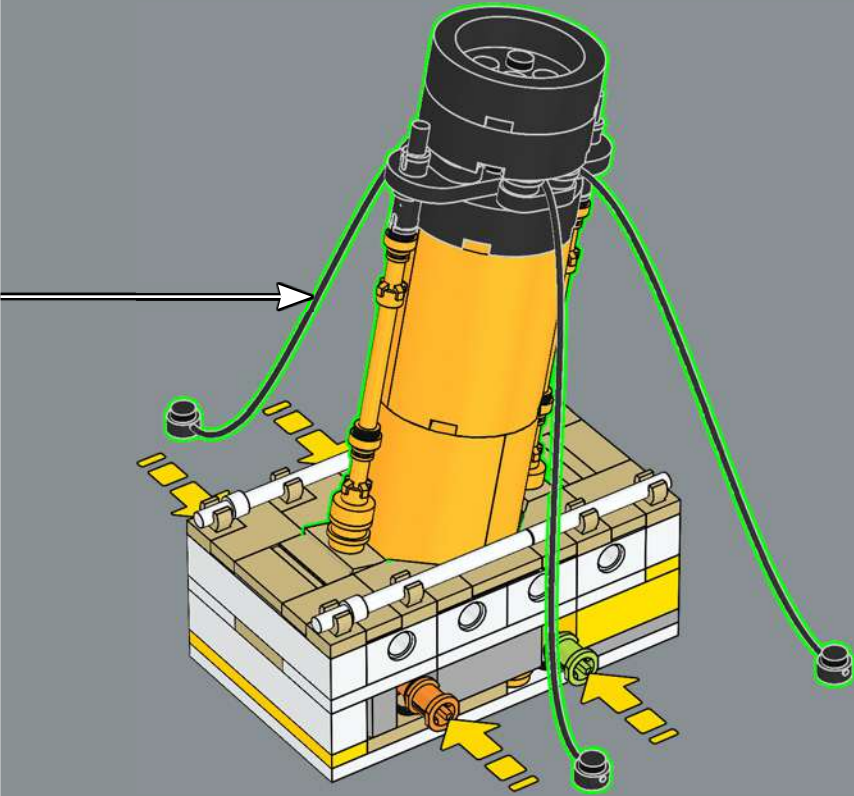

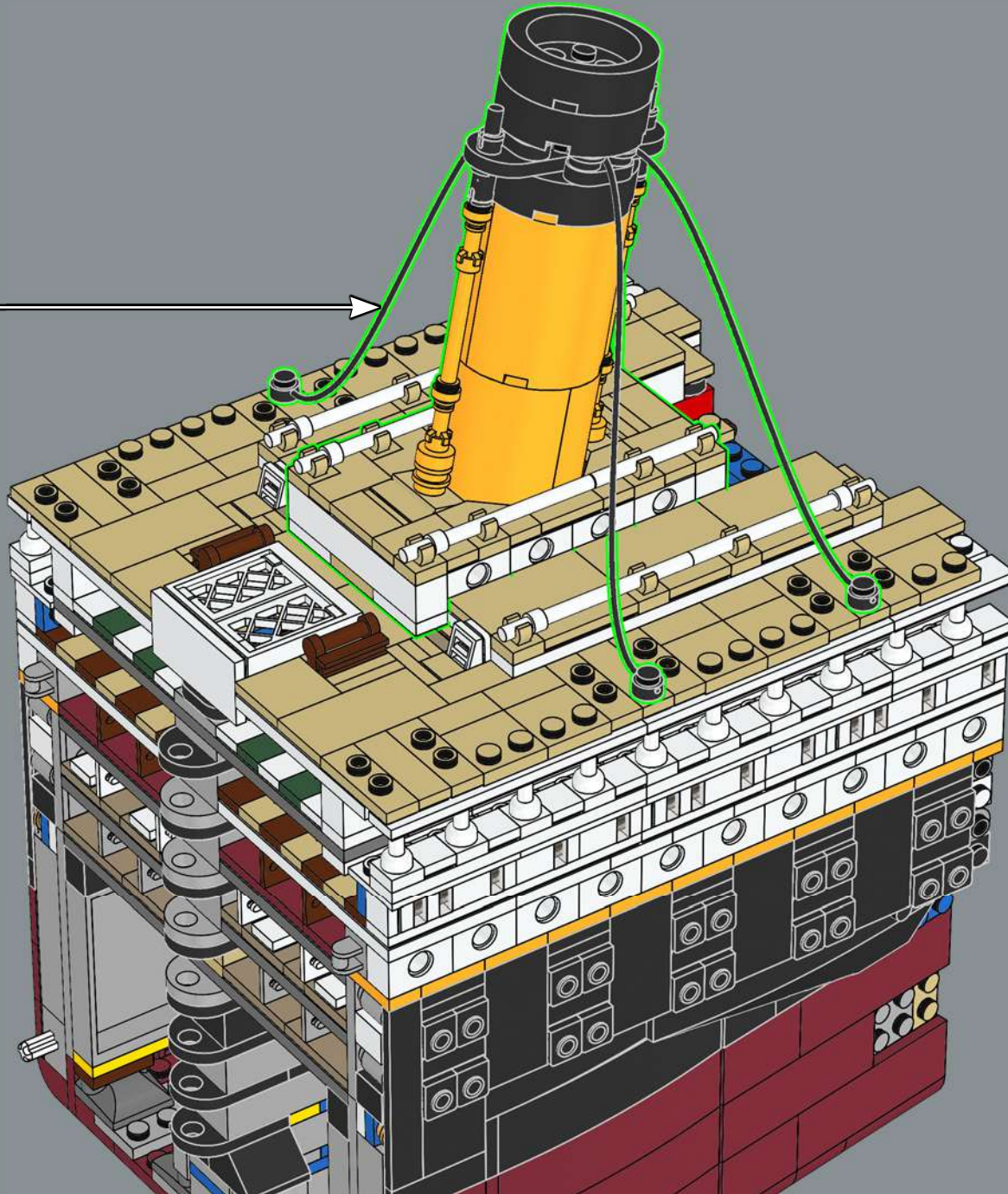

The *Titanic* had four funnels, though only three were functional—the last one was a dummy, installed for aesthetic purposes.

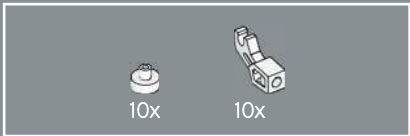

144

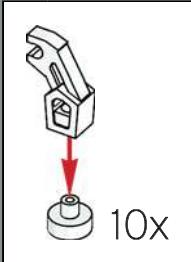
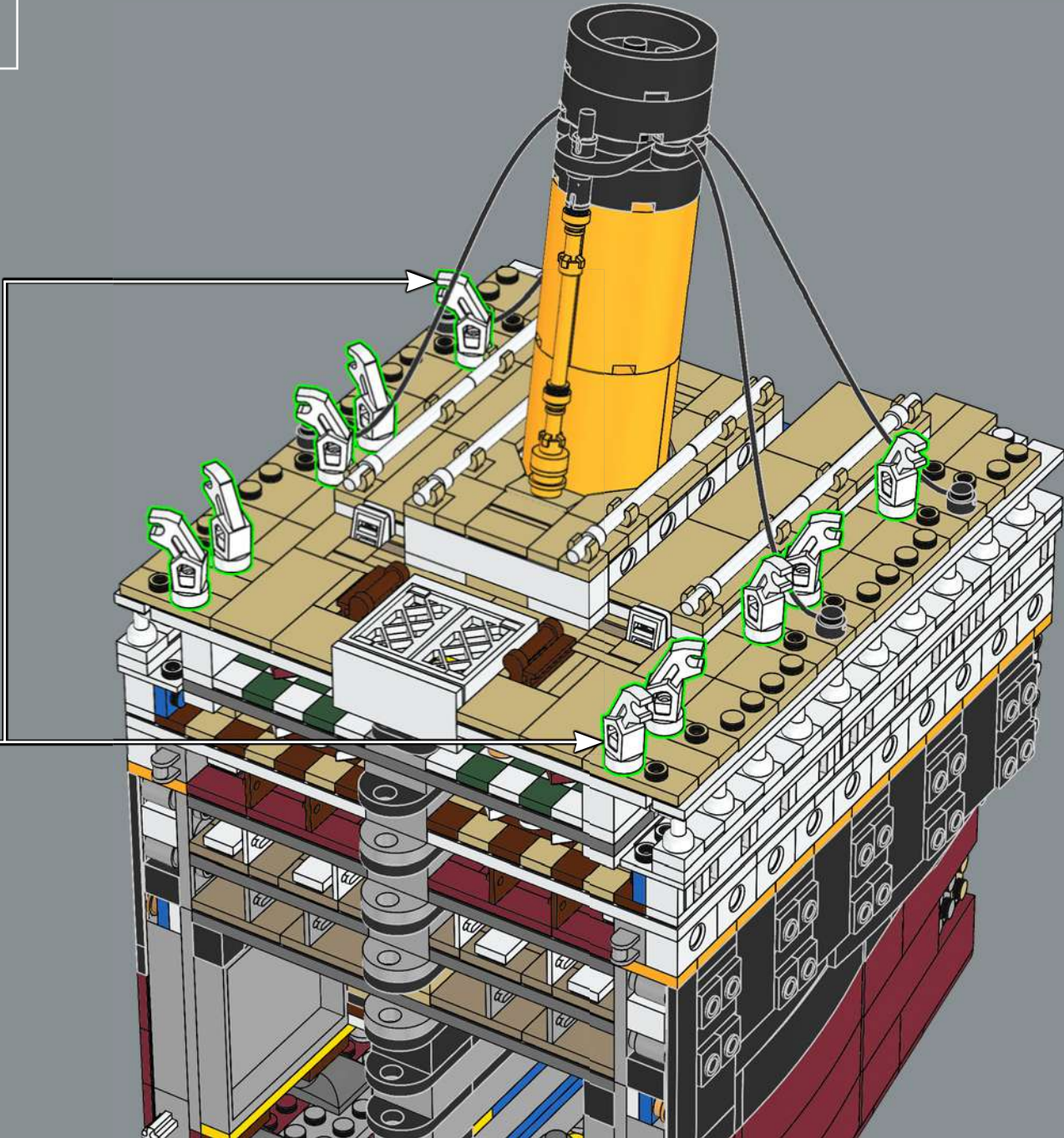

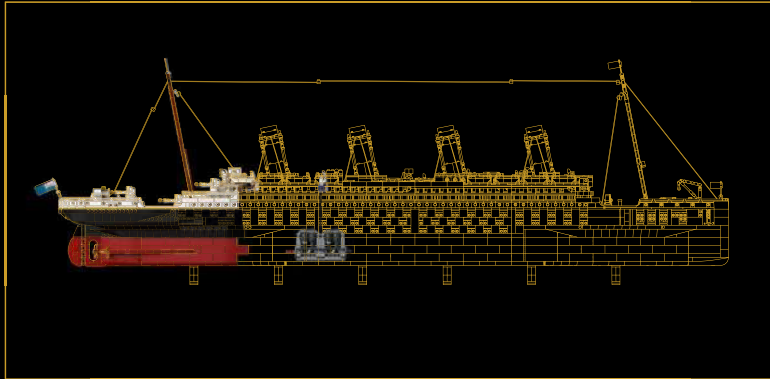

SECTION 6:

STERN & WELL DECK

This final section is the most complicated section of the hull and includes the rudder and three main driveshafts that connect the propellers to the engines. You will build the two main piston engines that are linked directly to the port and starboard screws. Turning the screws moves the engine crankshafts and pistons inside the model.

↓ The exterior details of this section include the stern bridge and benches for the 3rd class passengers.



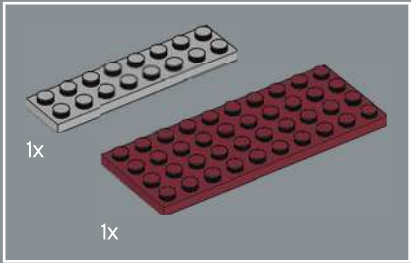
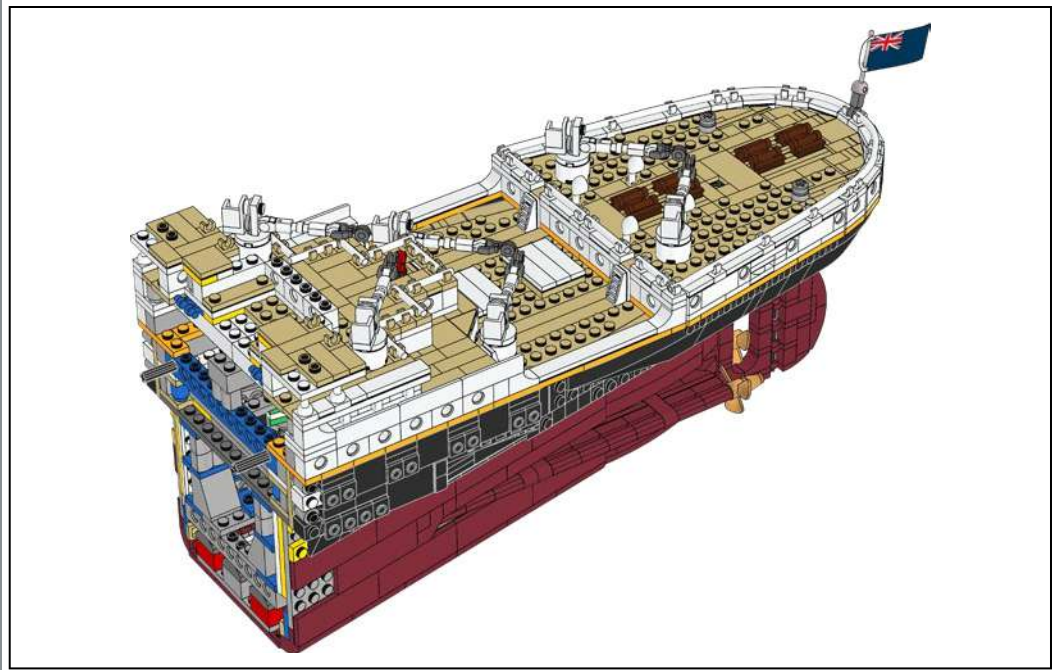
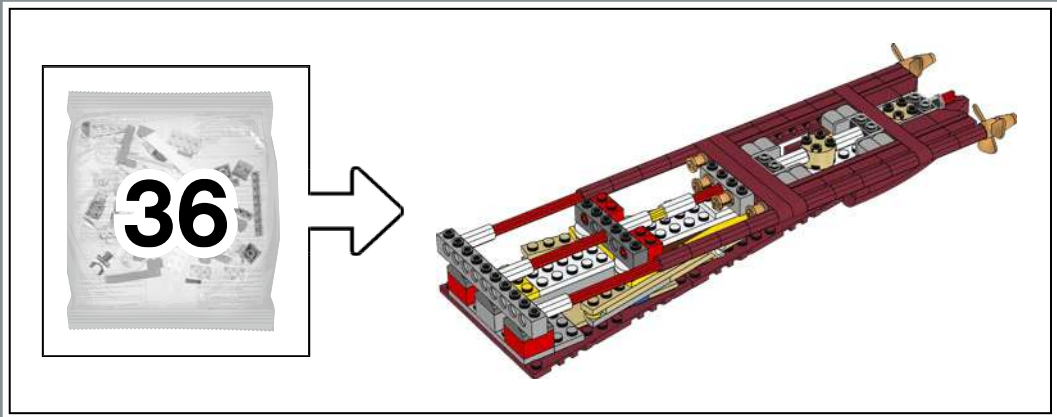

146

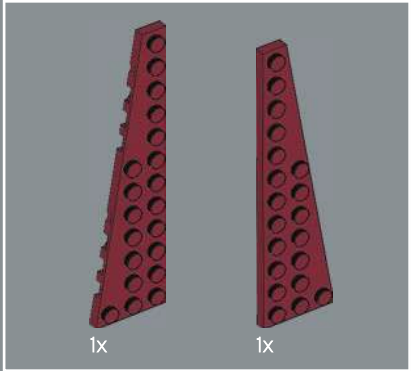
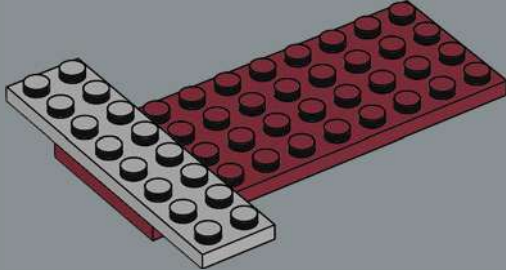

147

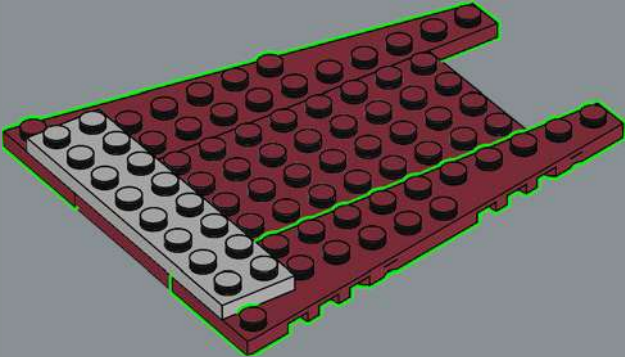

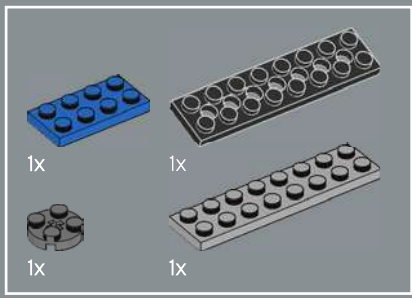

148

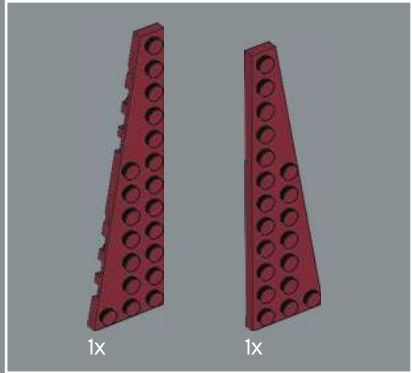
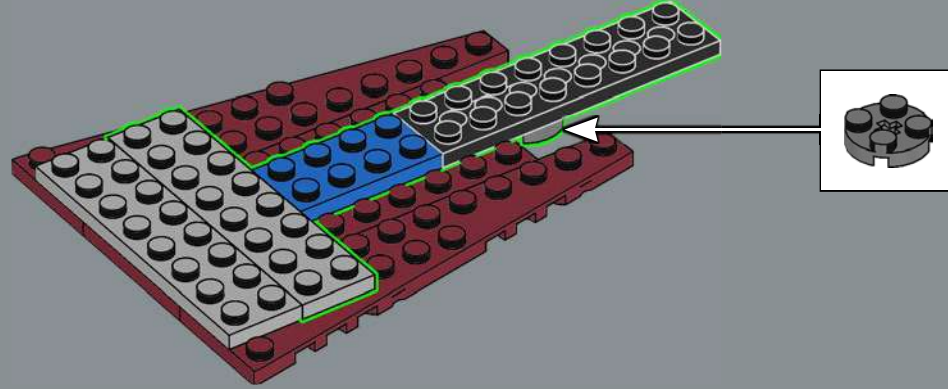

149

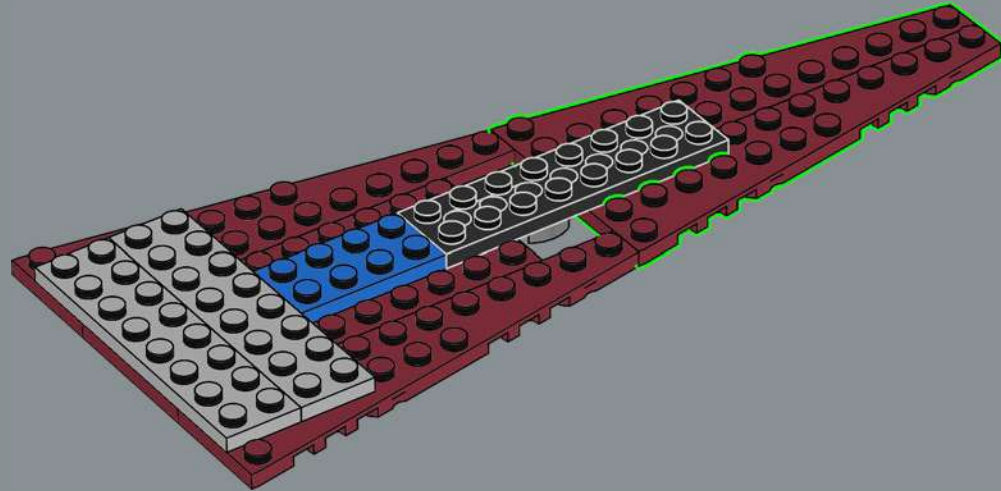

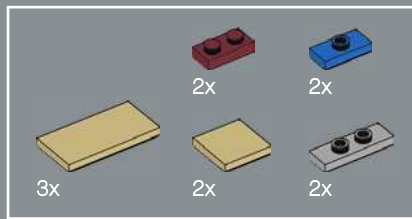

150

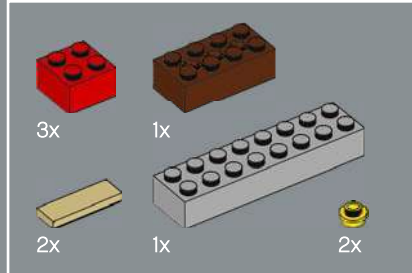
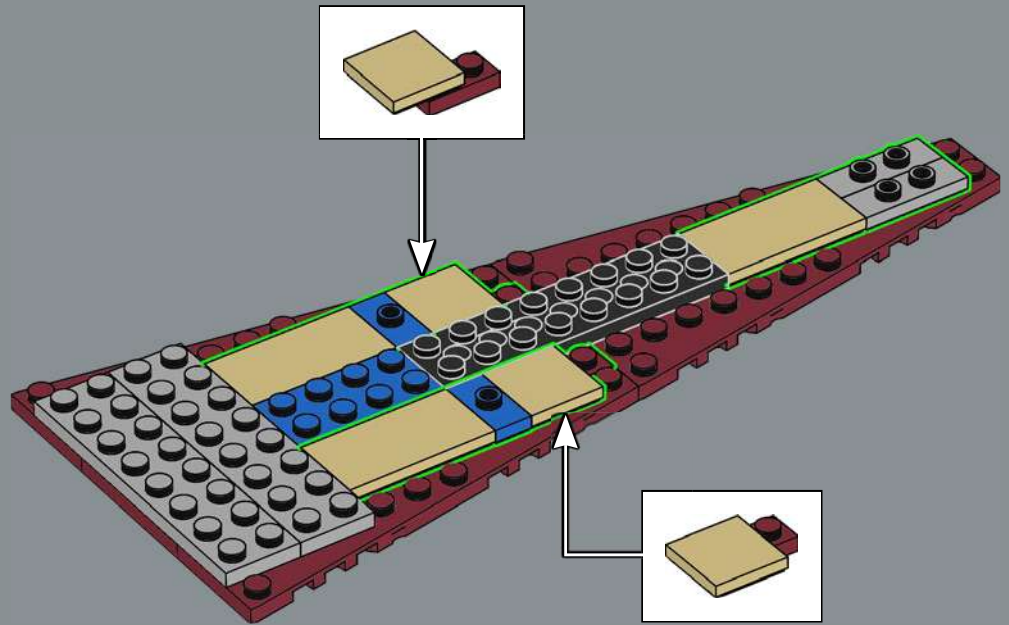

151

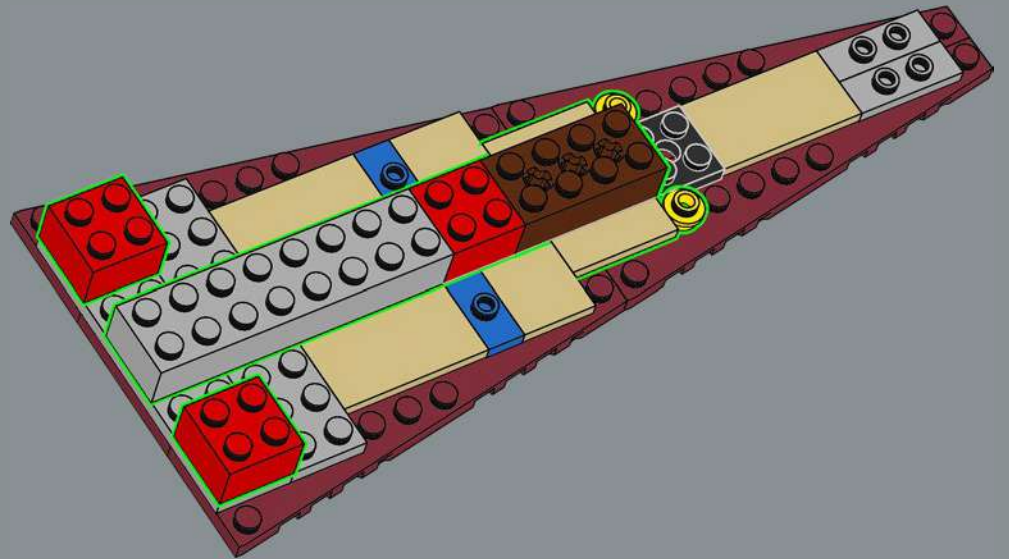

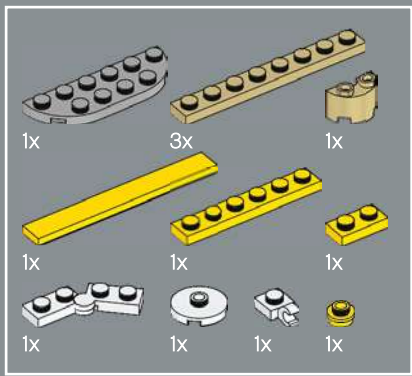

152

1



2

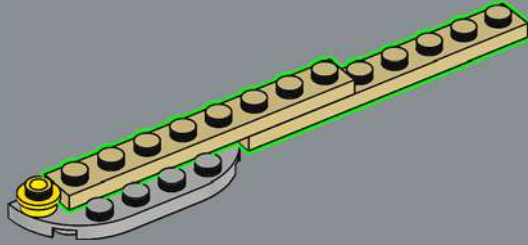

3

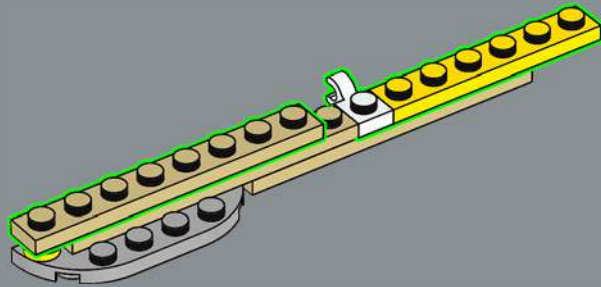

4

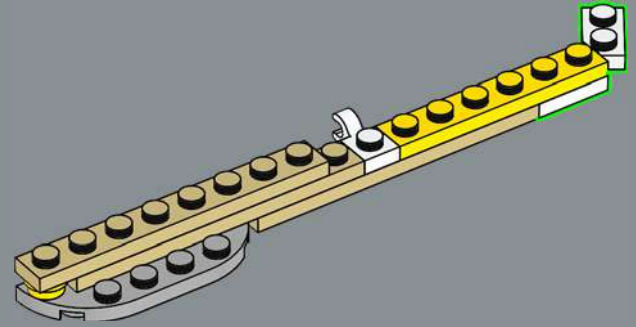

5

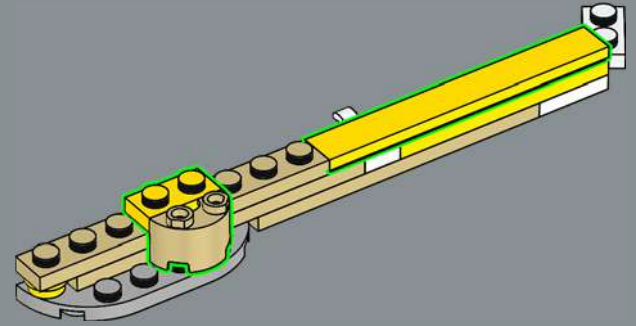

6

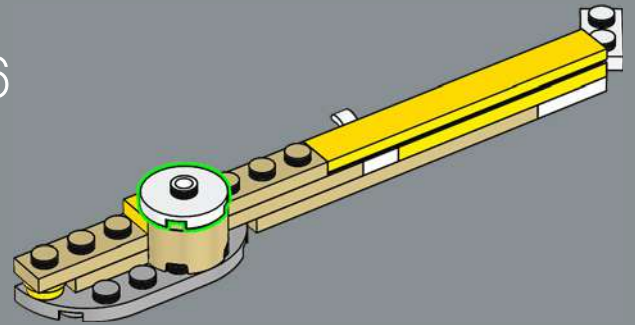

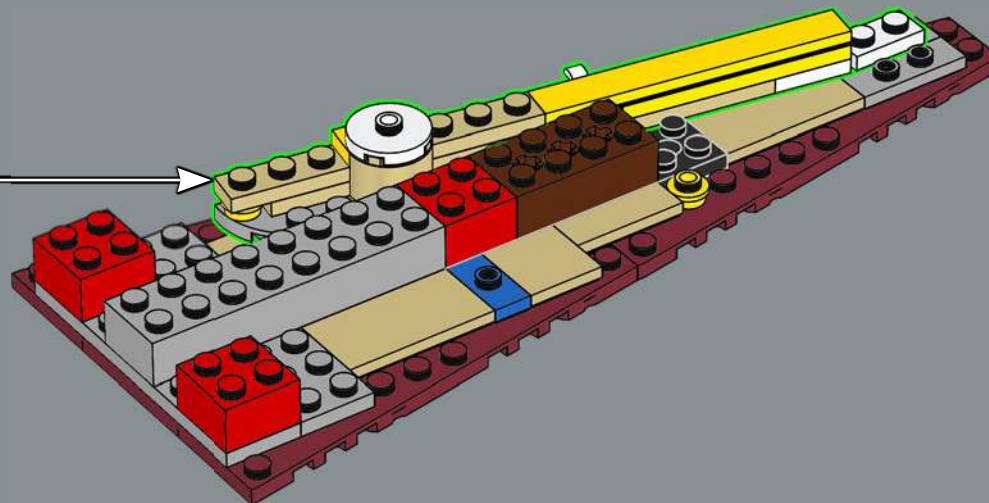

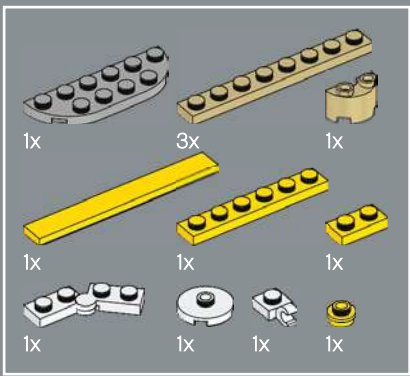

153

1

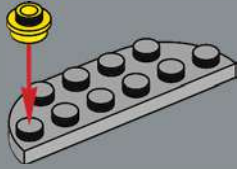

2

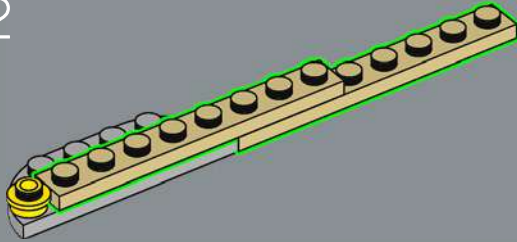

3

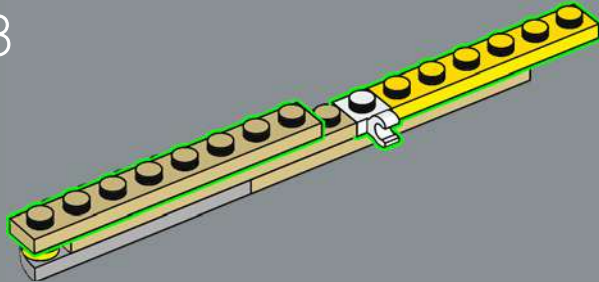

4

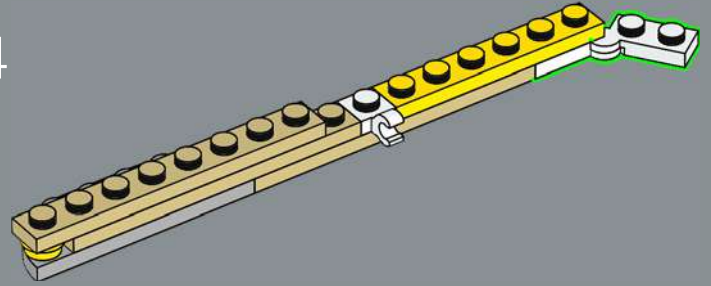

5

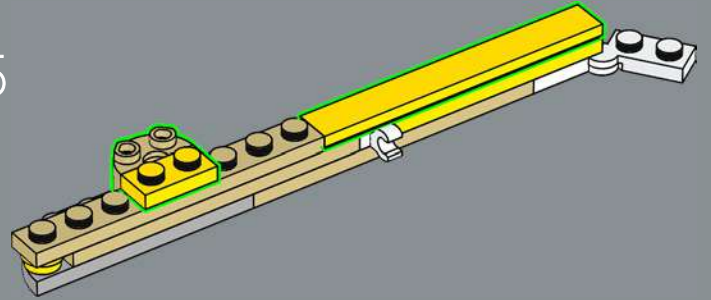

6

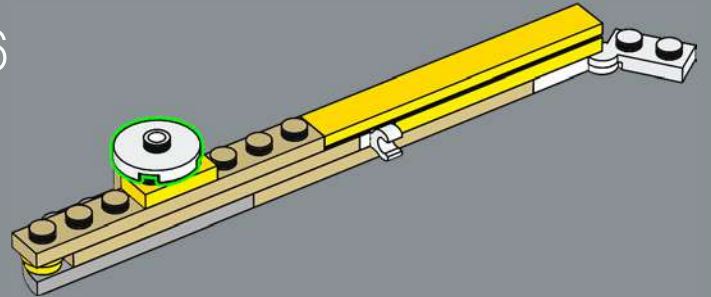

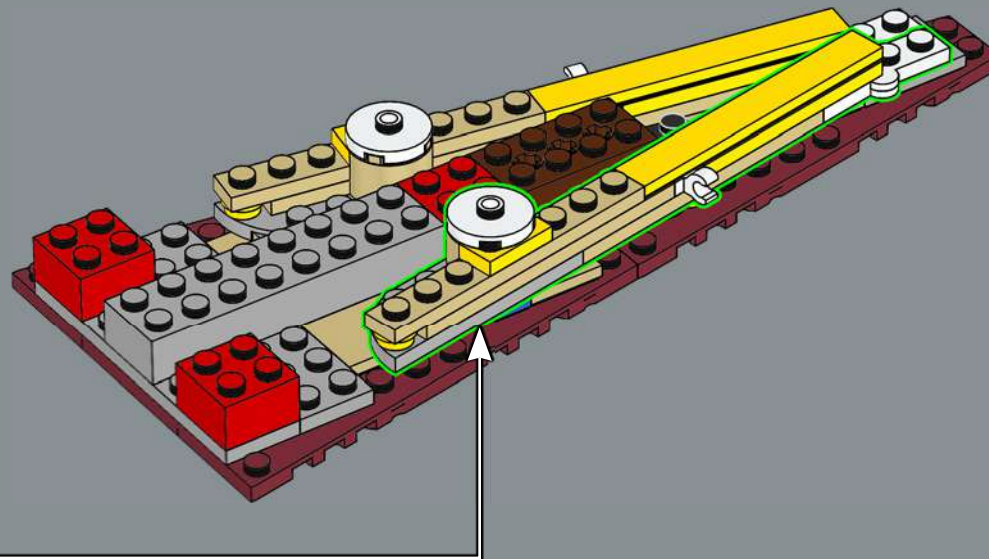

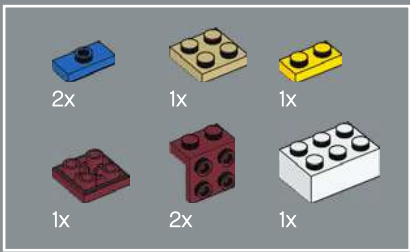

154

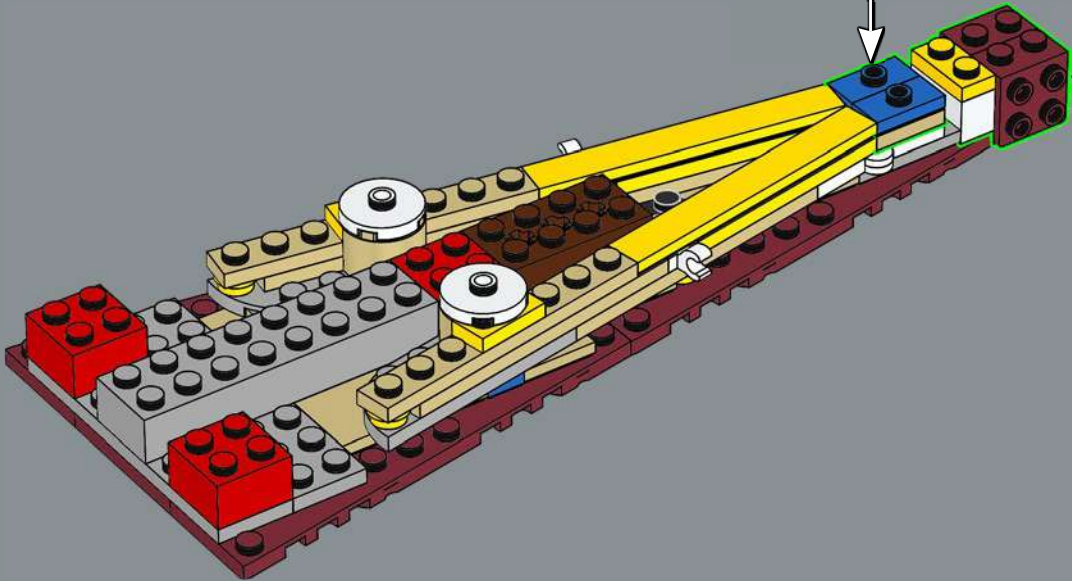
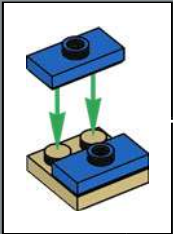
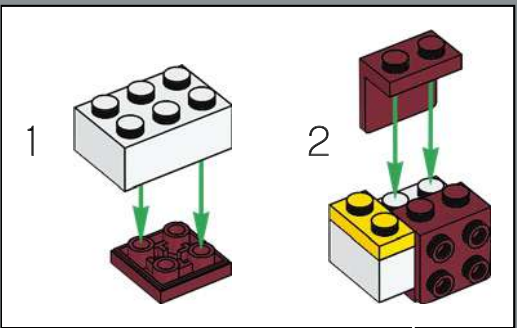

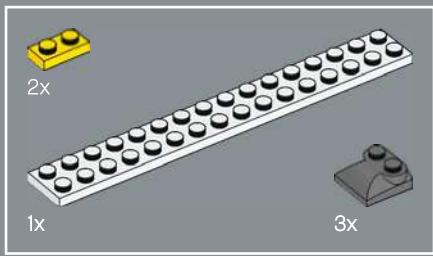

155

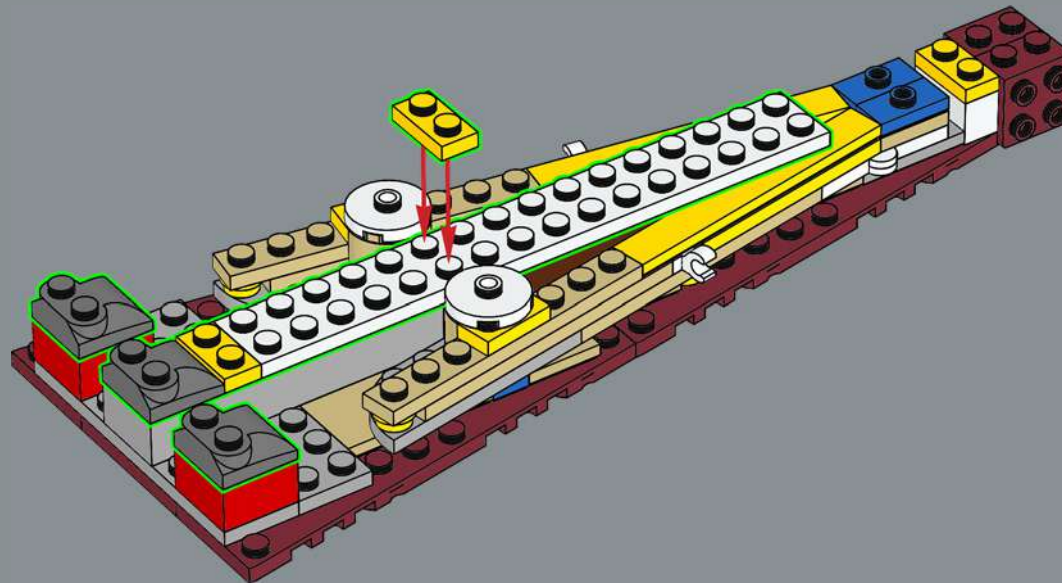

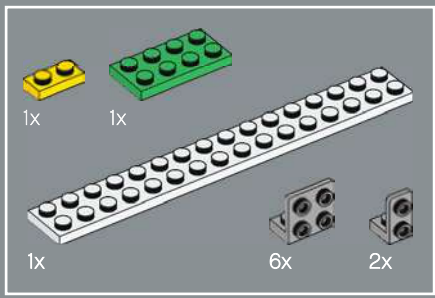

156

1

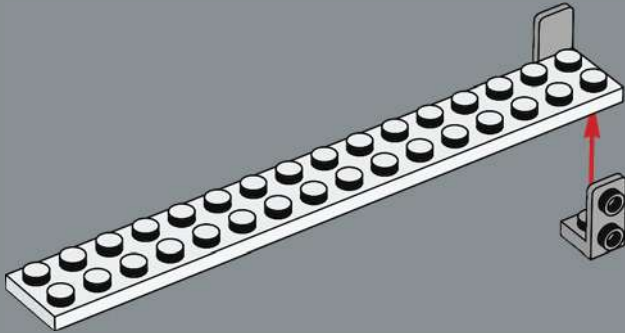

2

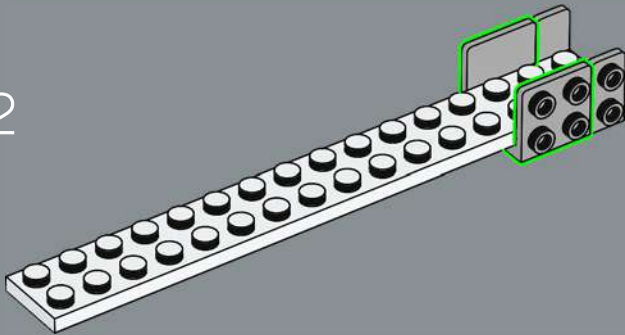

3

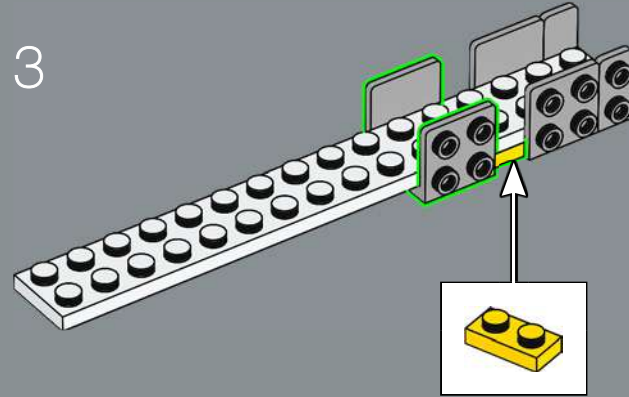

4

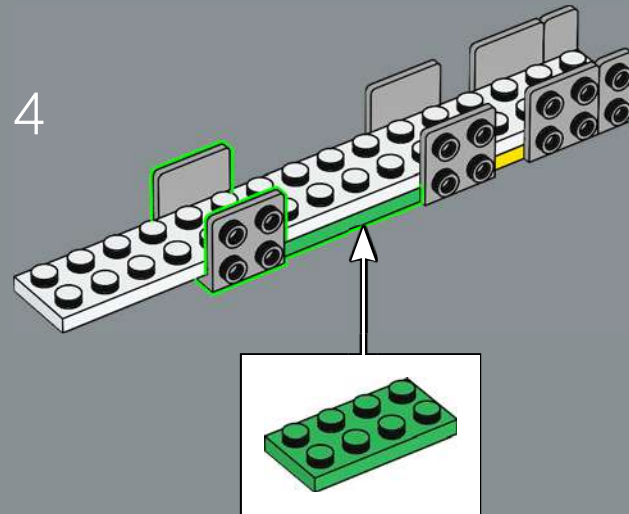

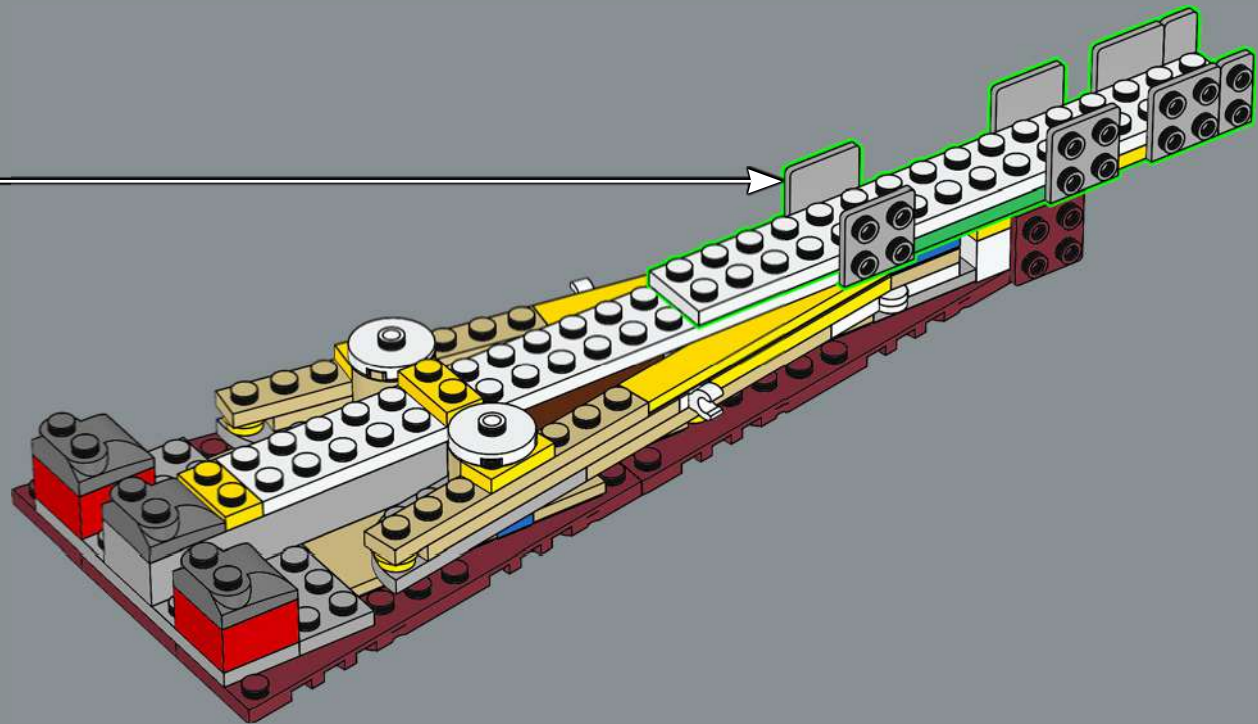



157

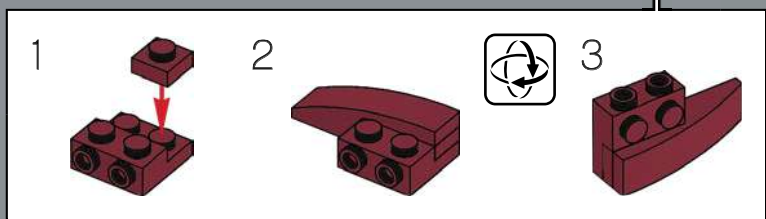
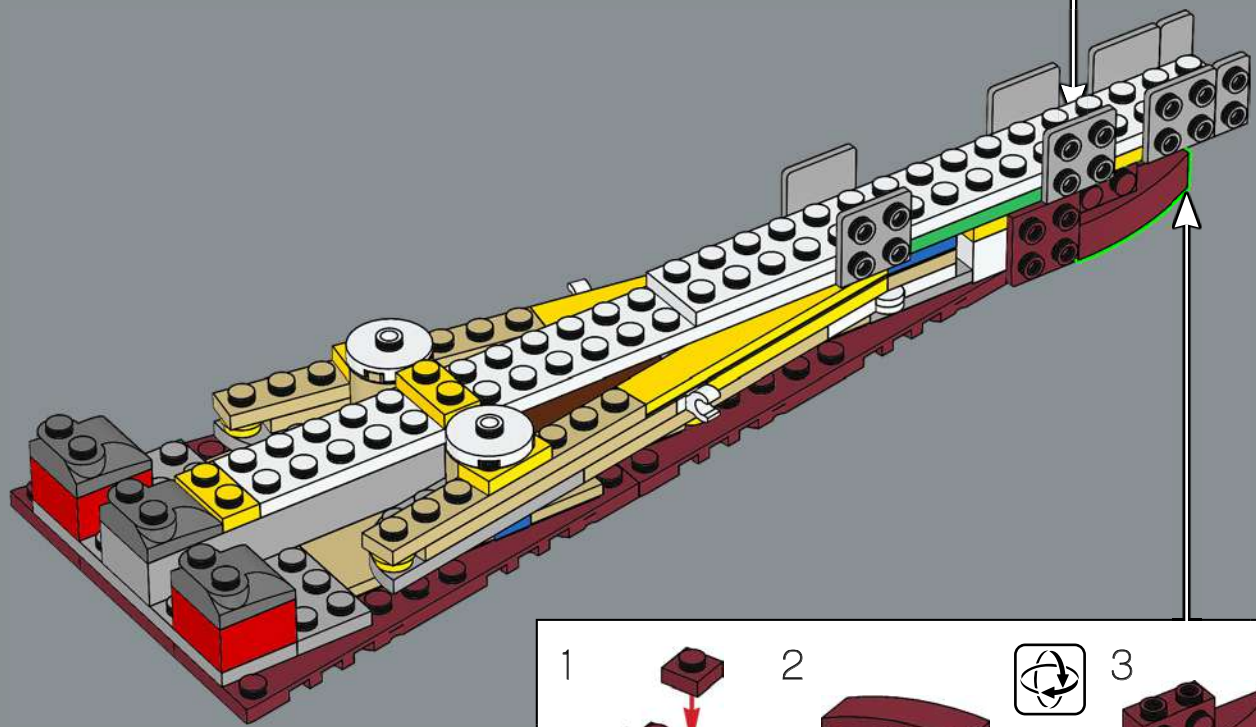
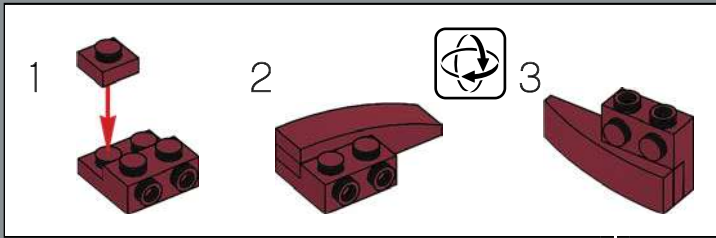

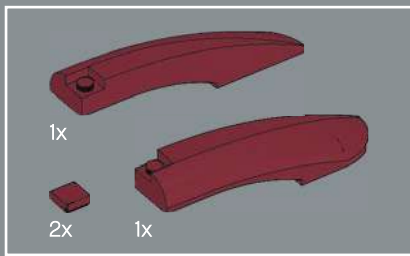

158

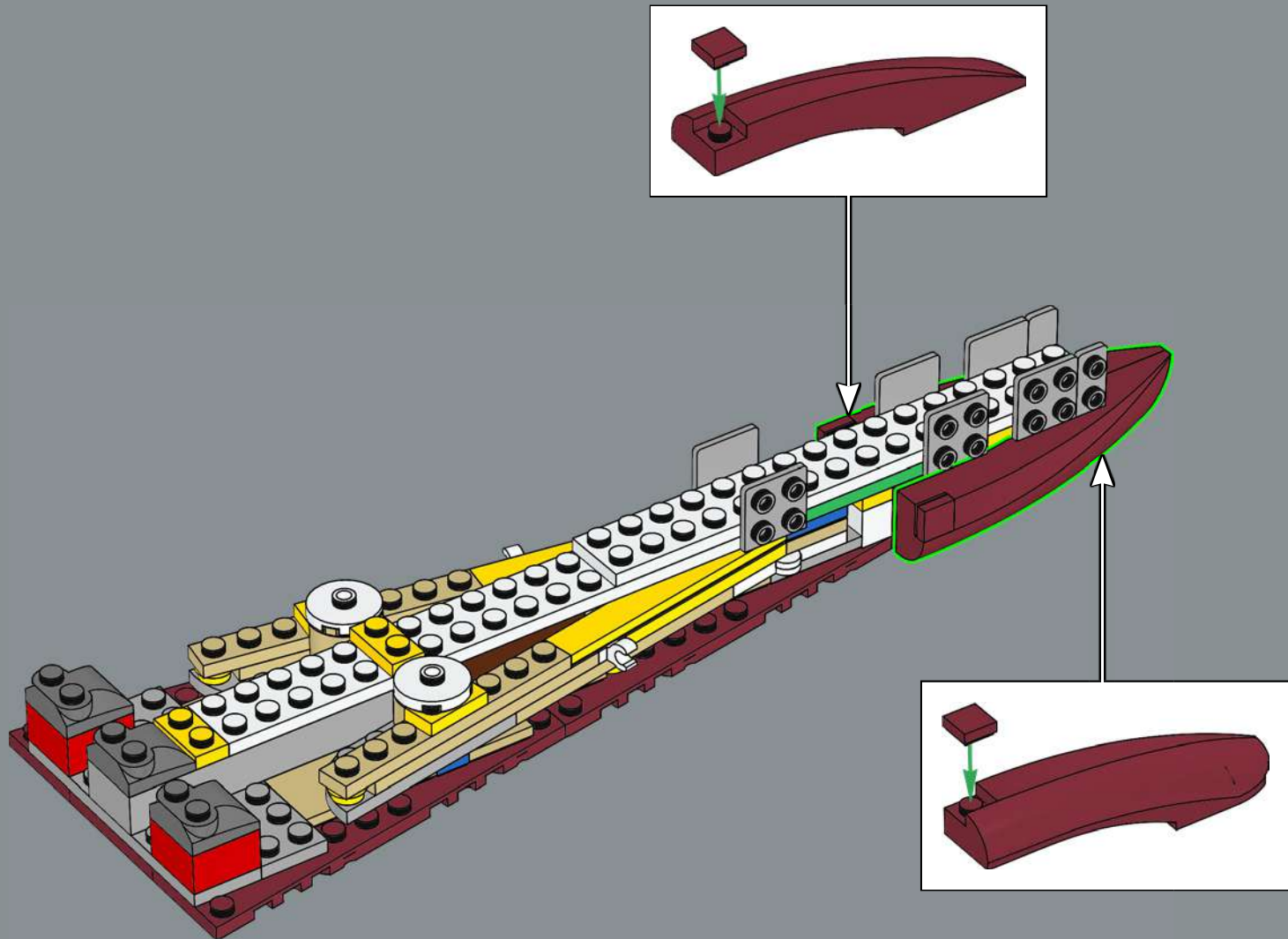

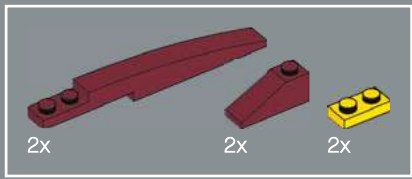

159

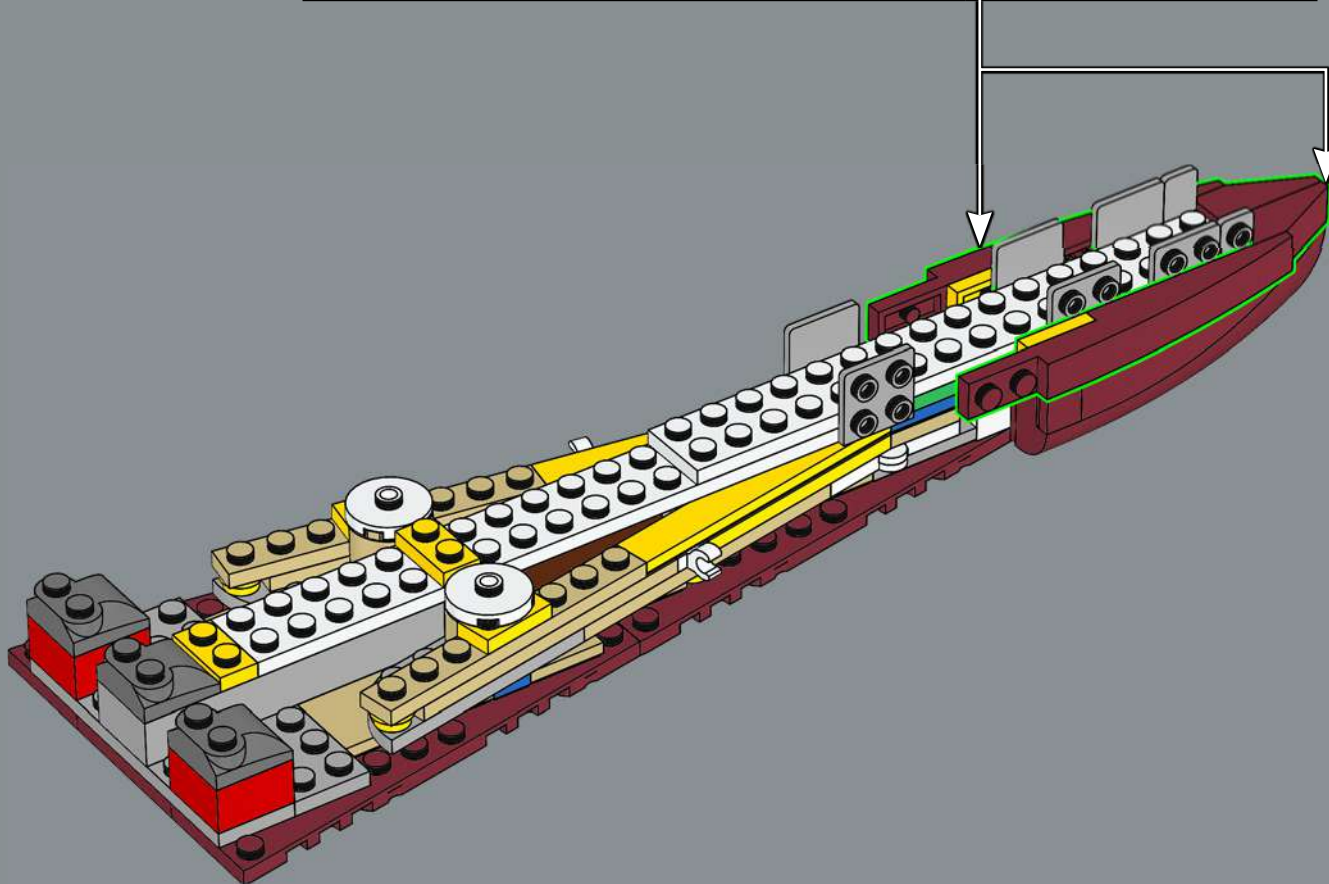
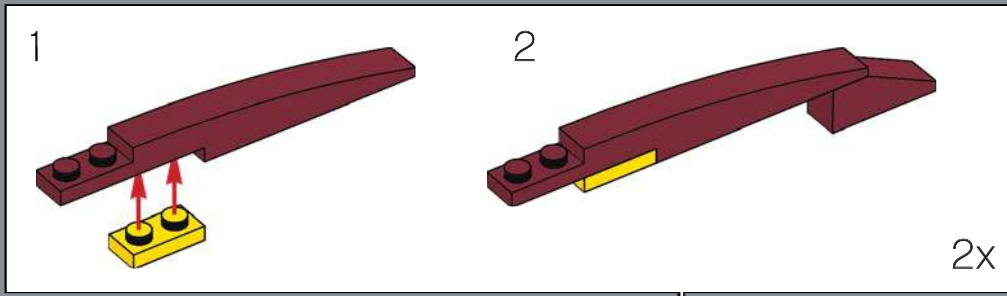

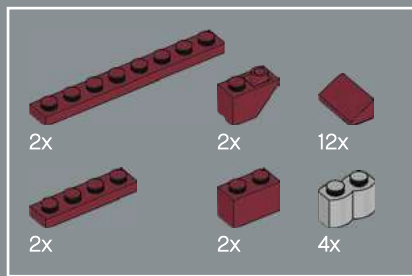

160

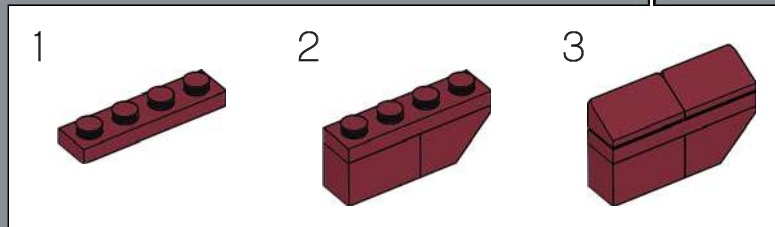
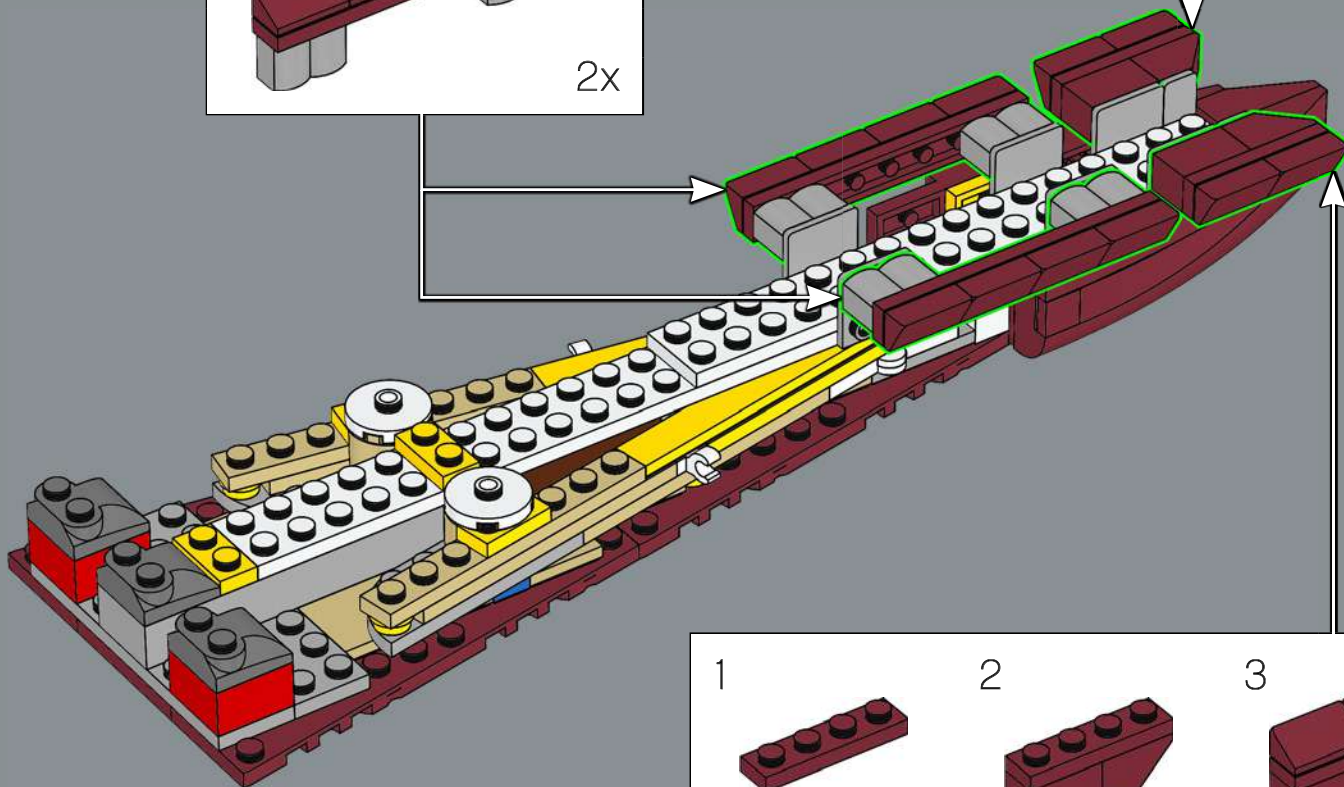
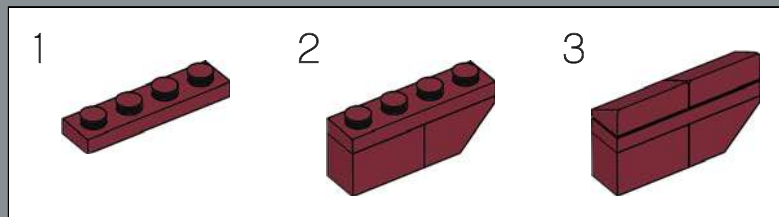
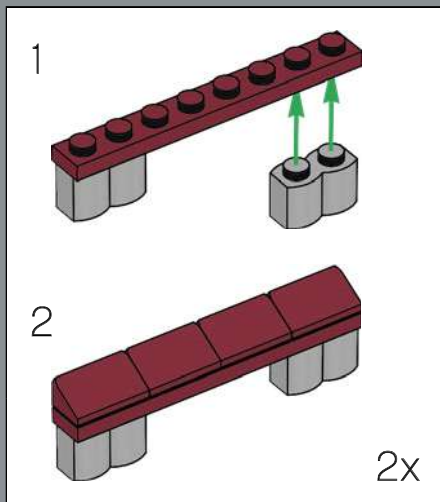

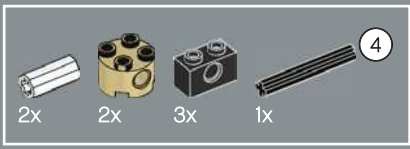

161

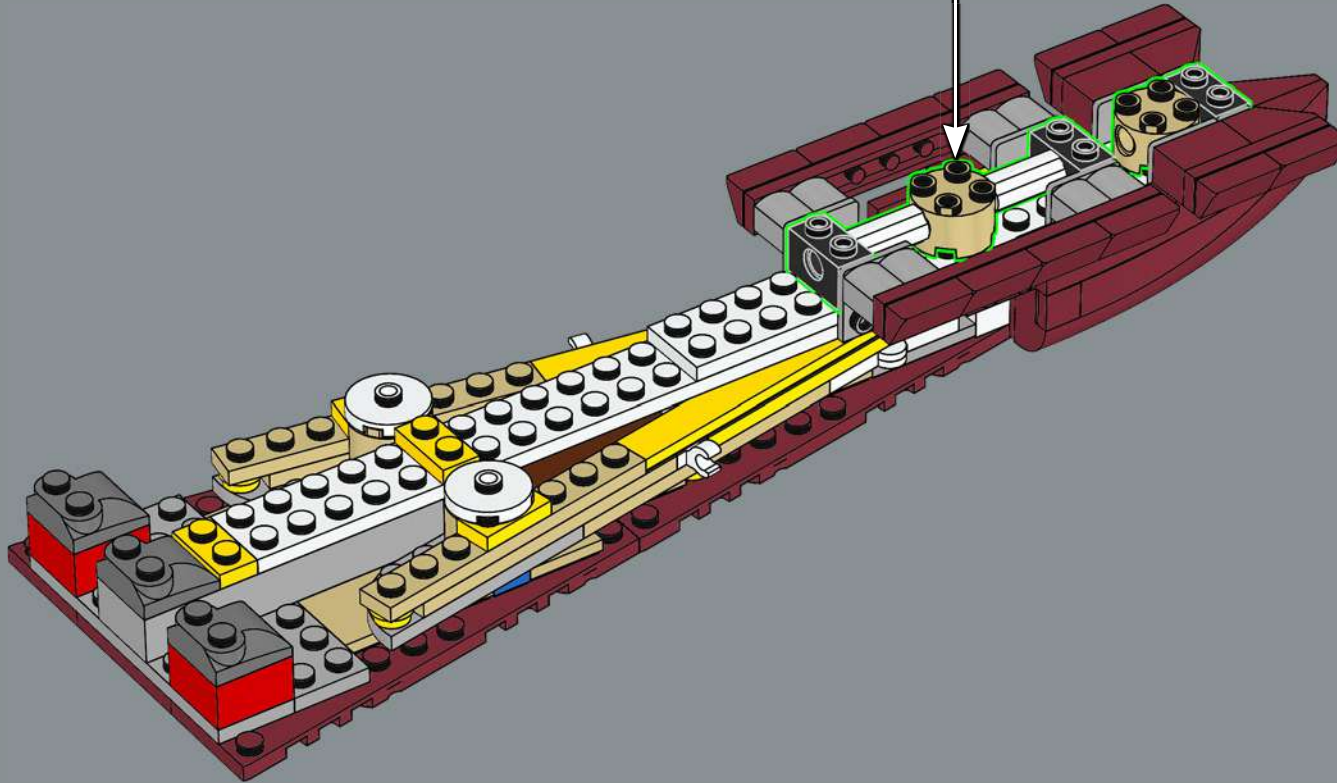
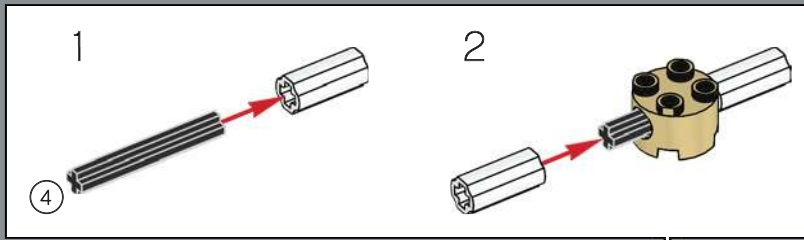

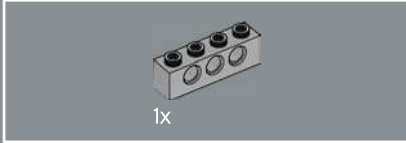
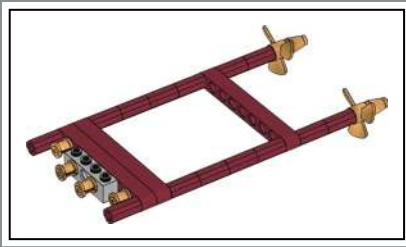

162

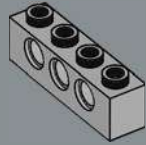

163

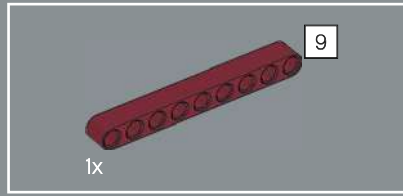
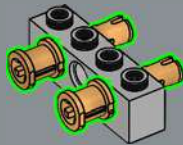

164

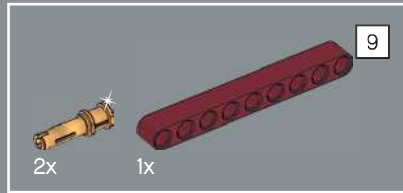
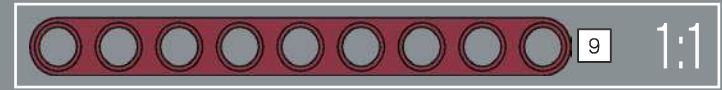

165

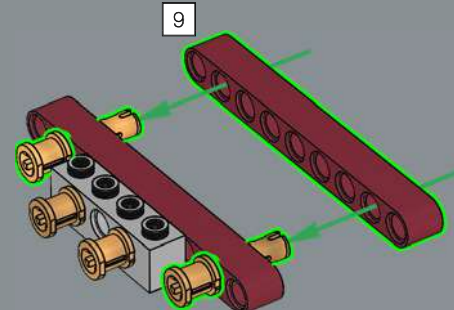
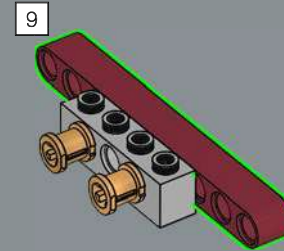

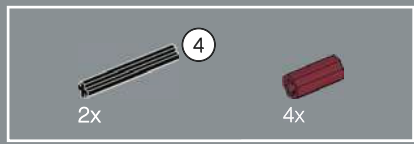

166

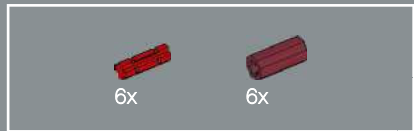
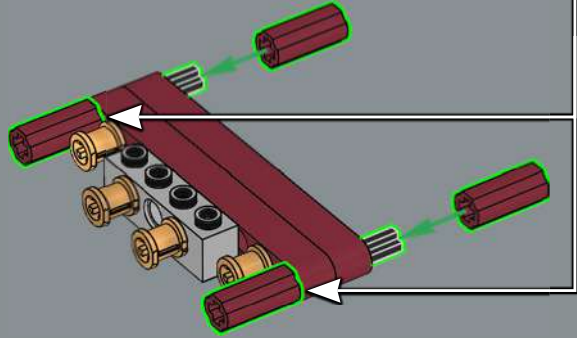
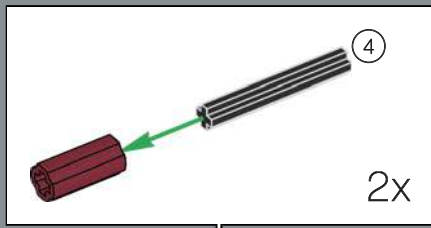

167

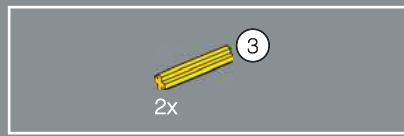
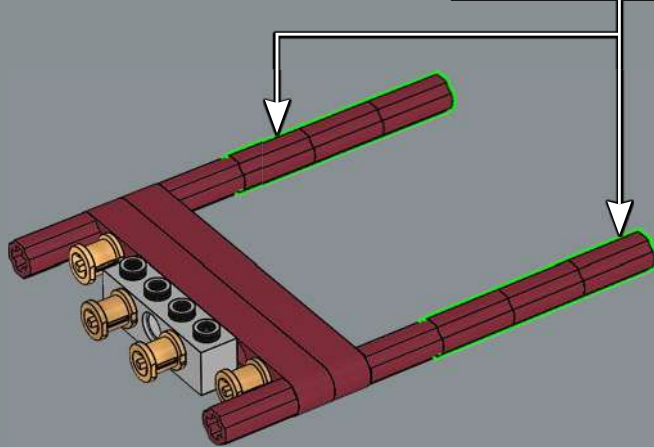
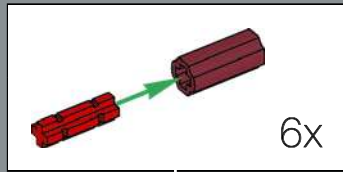

168

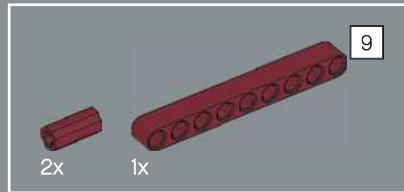
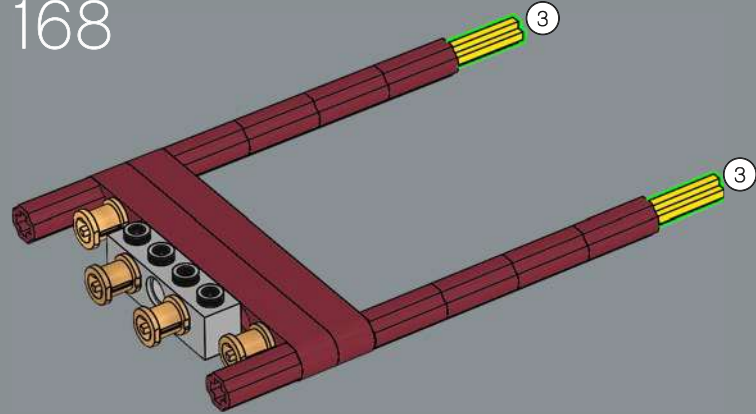

169

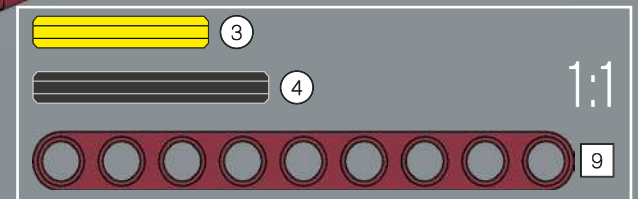
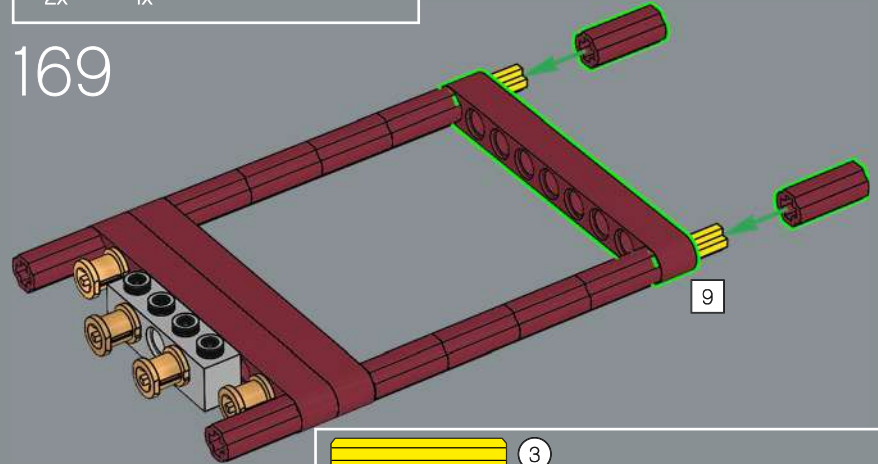

1:1

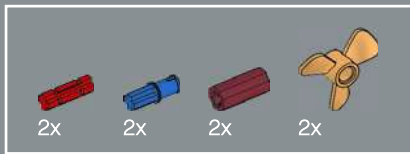

170

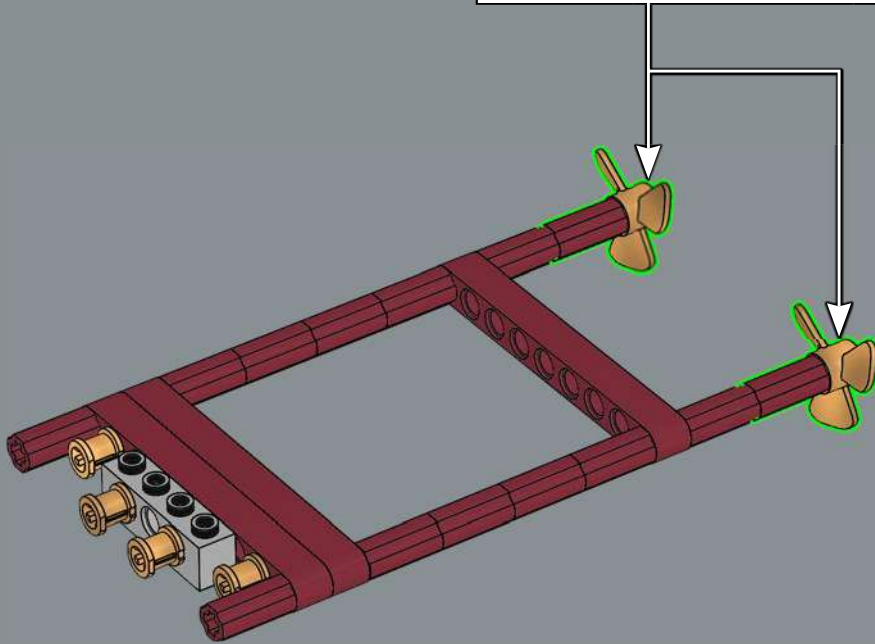
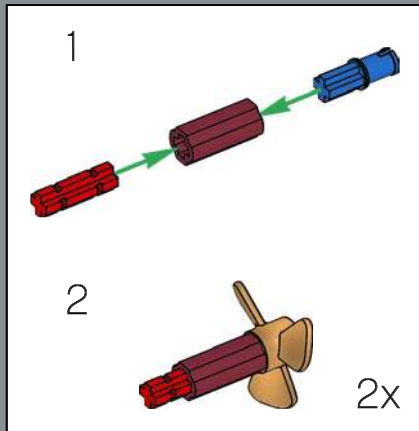

171

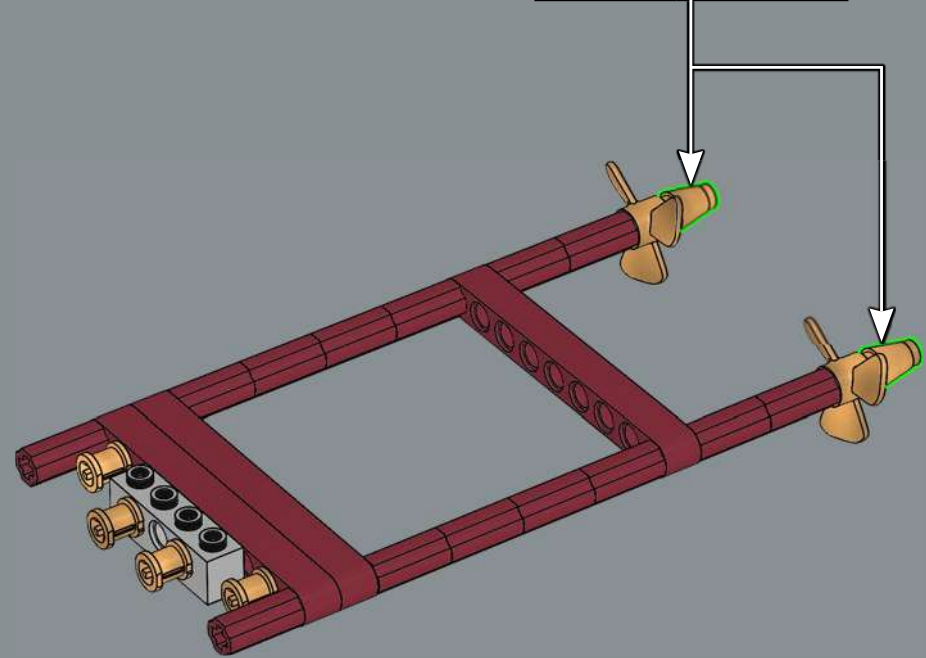
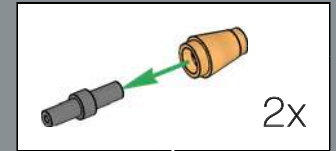

172

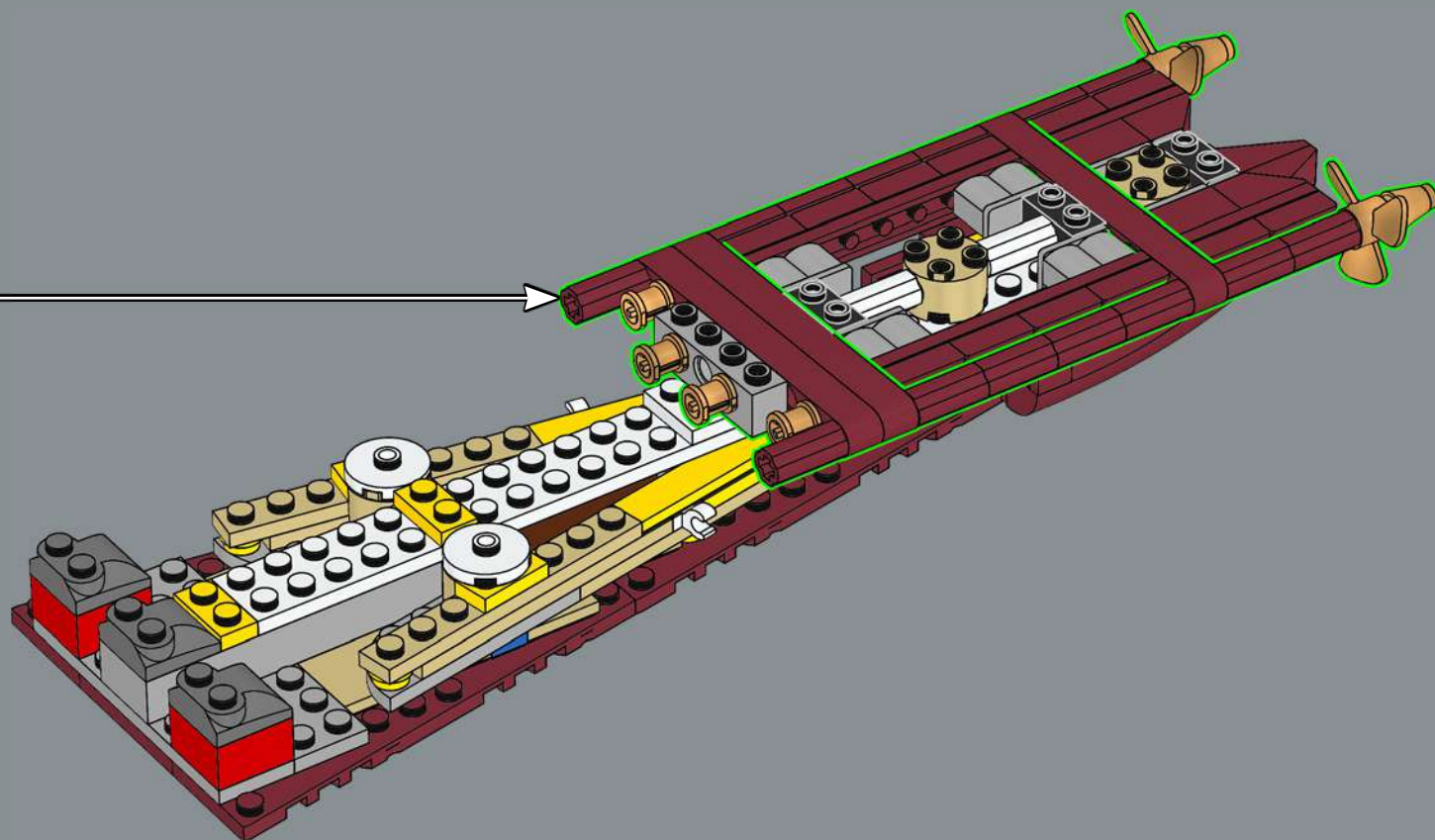

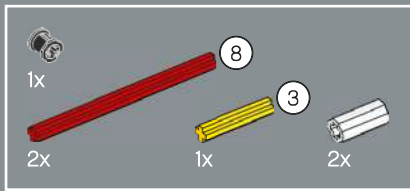

173

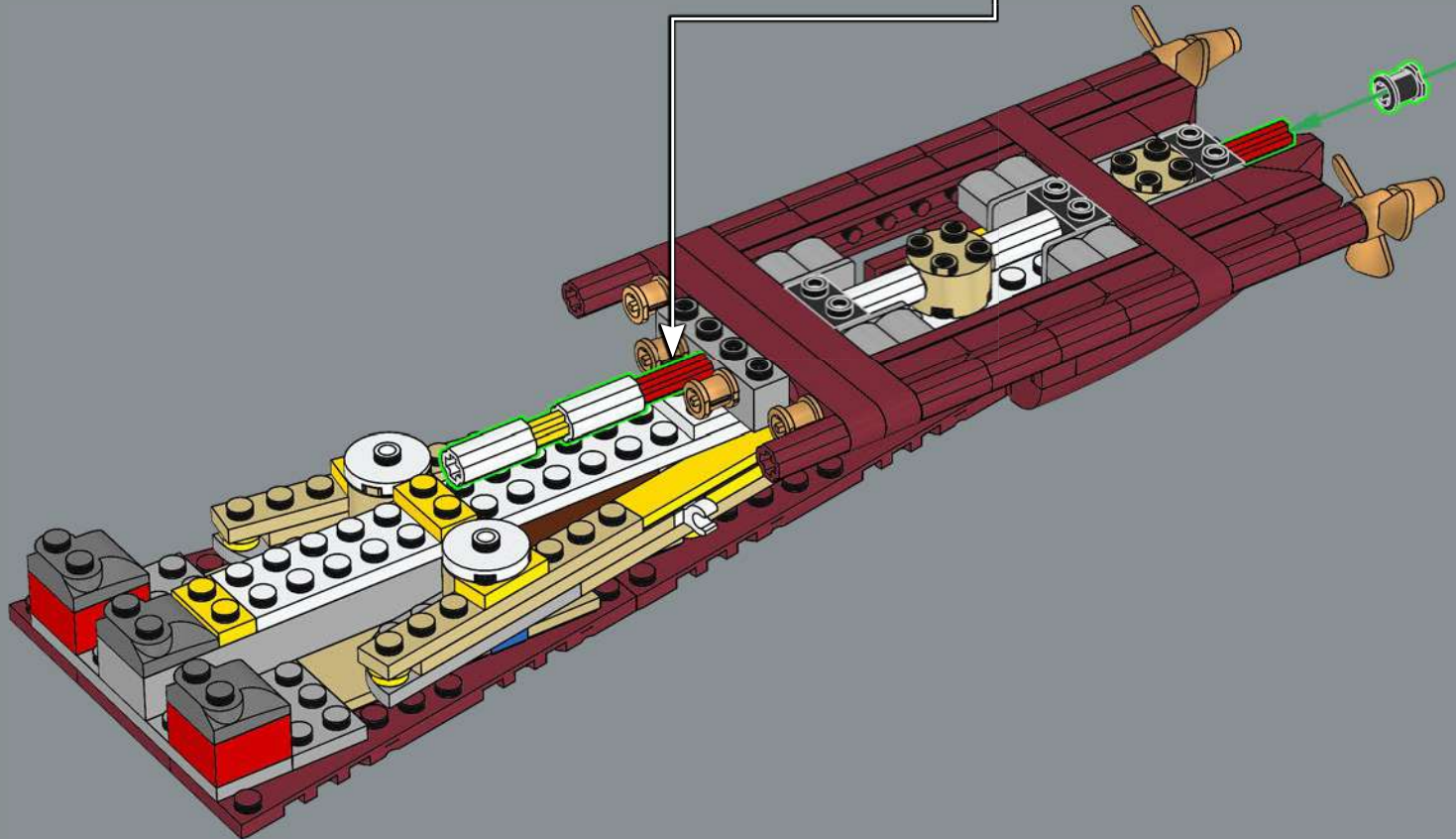
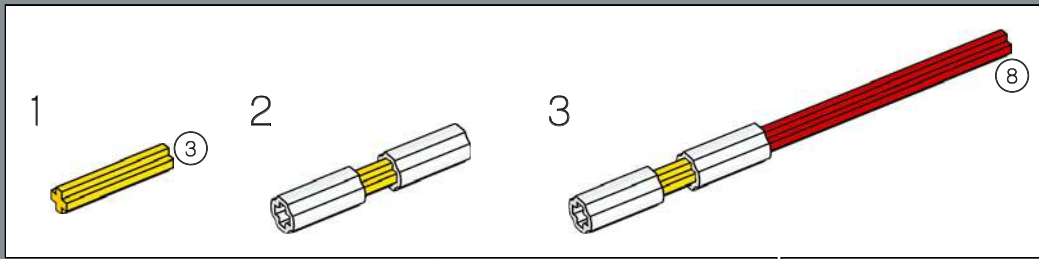

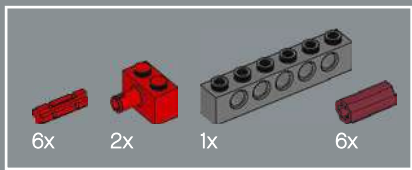

174

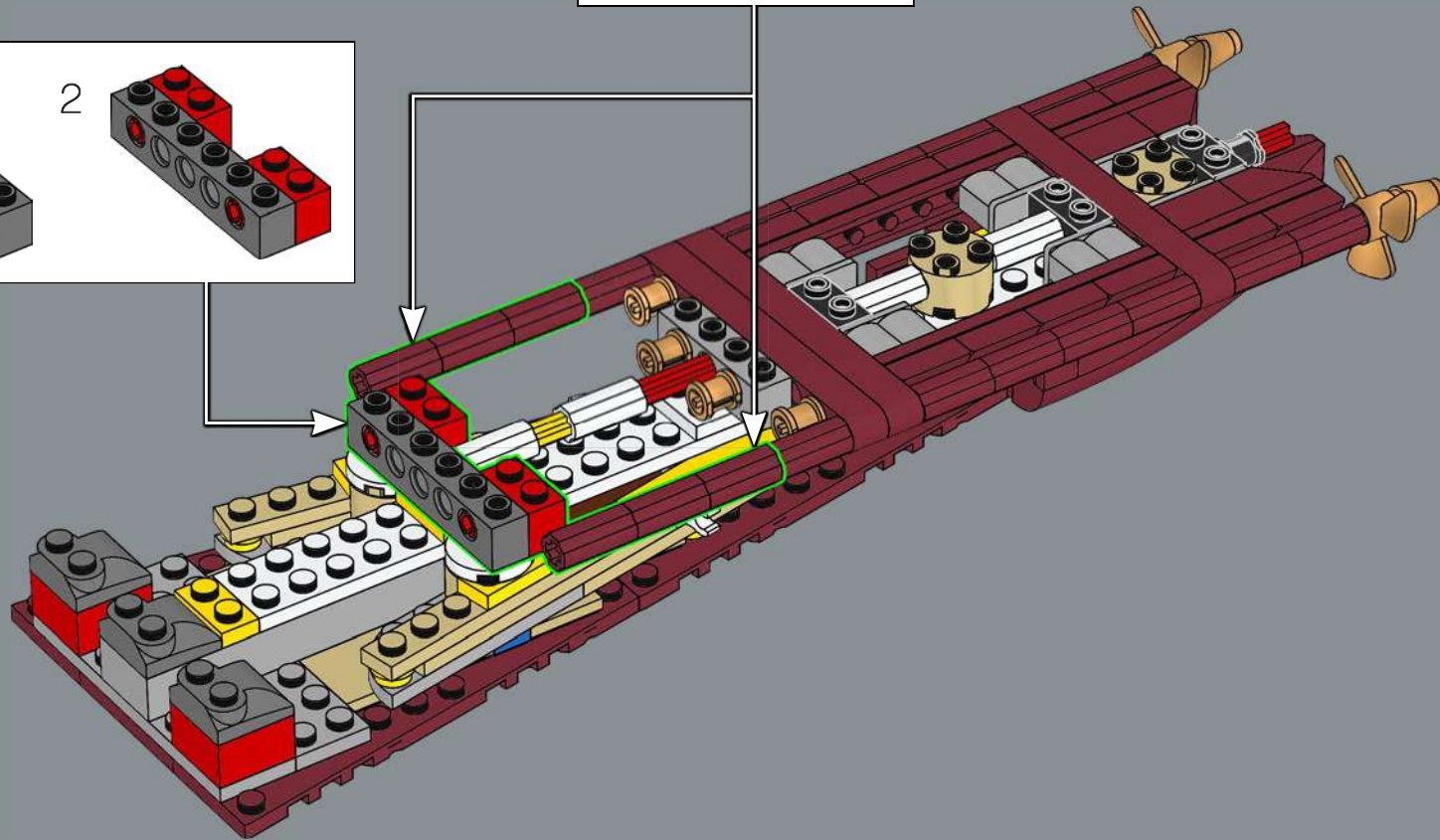
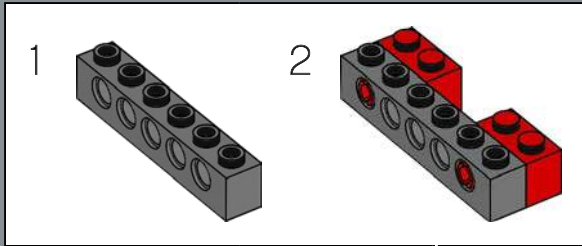
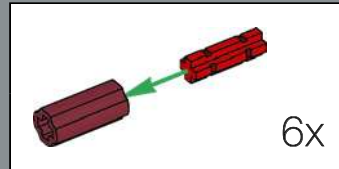

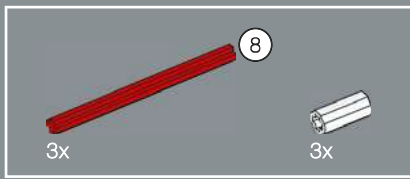

175

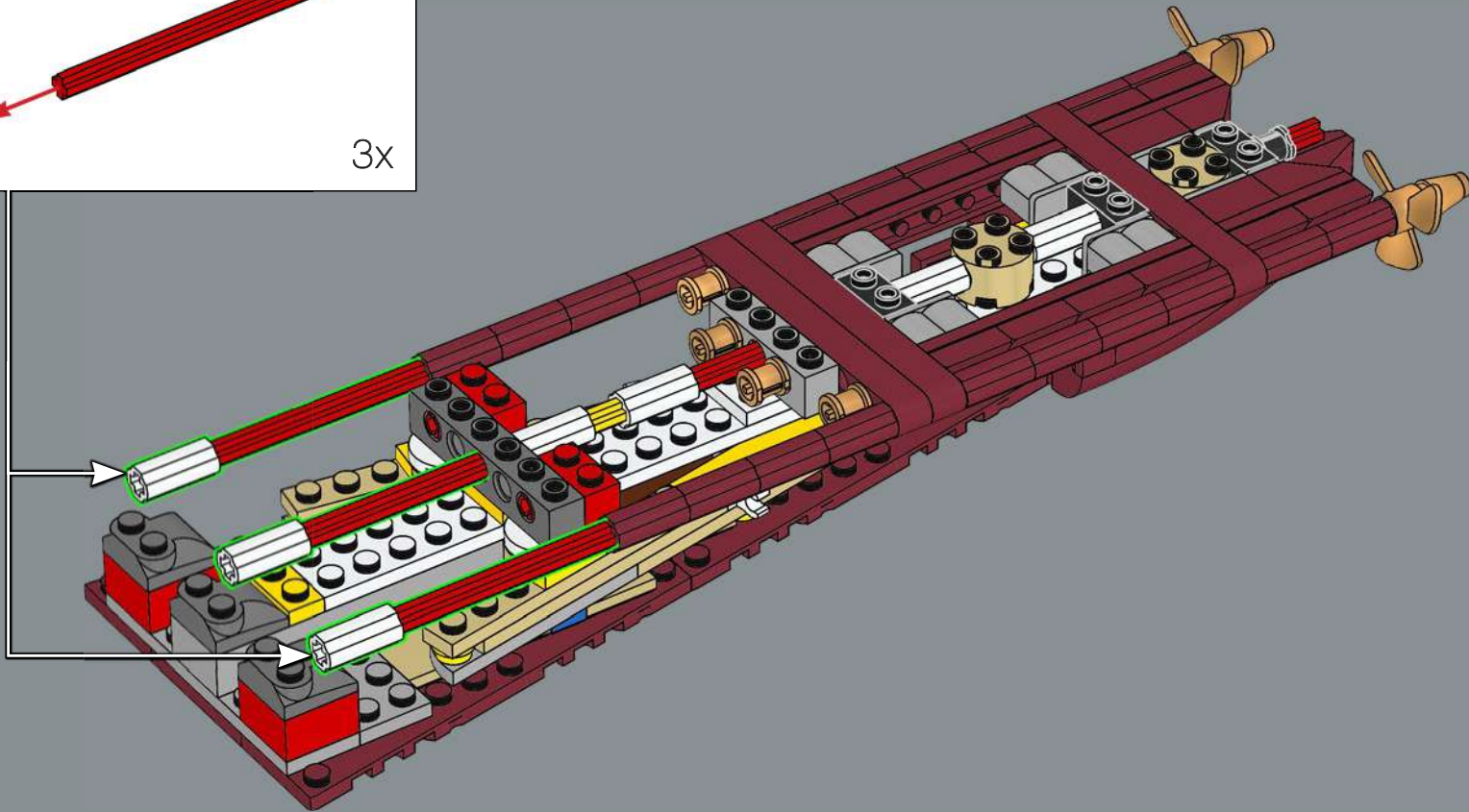
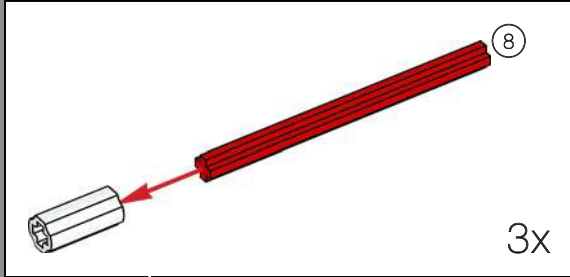

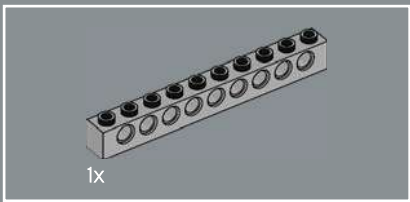

176

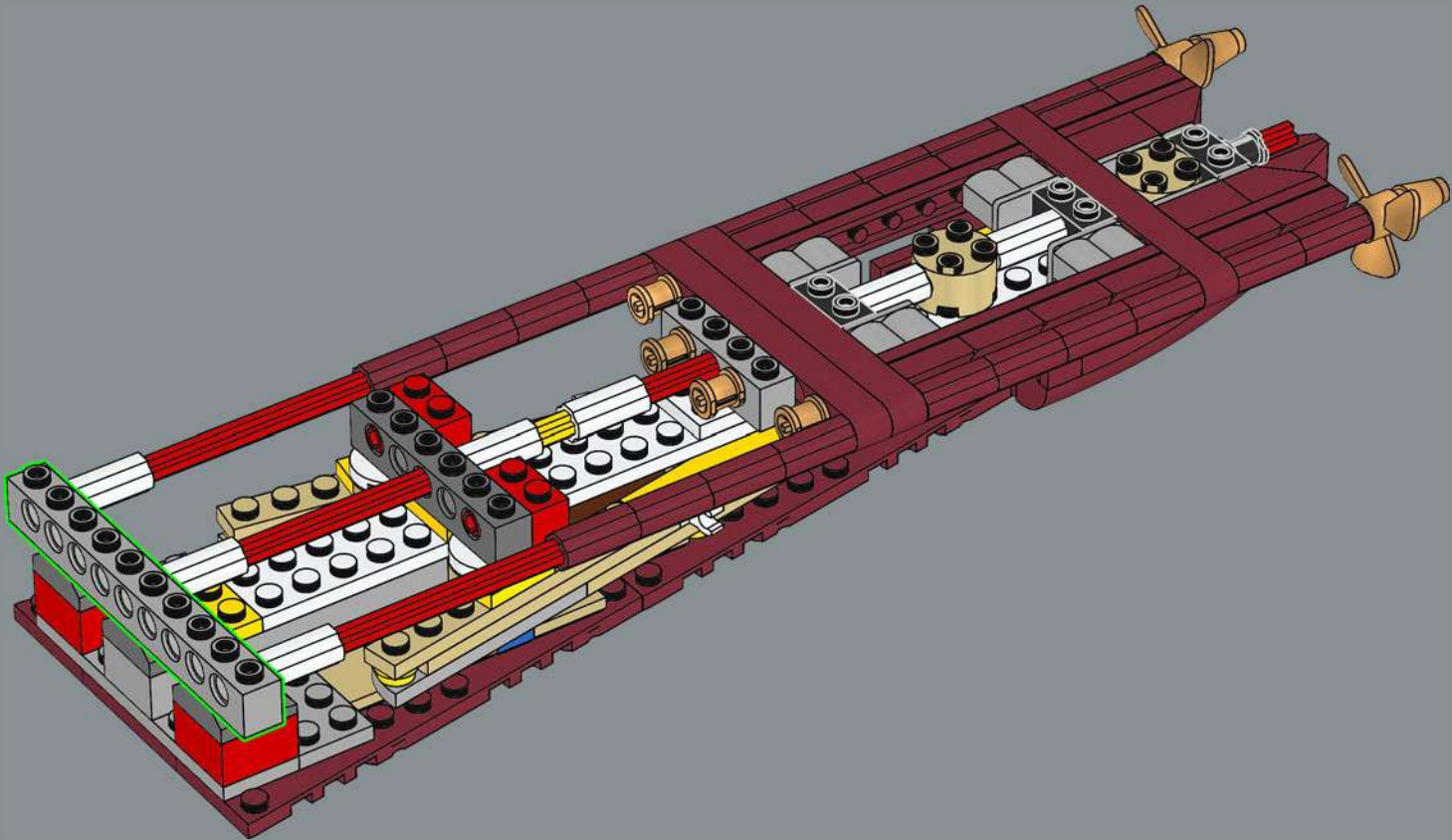

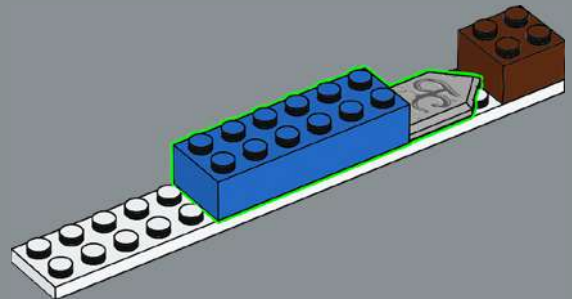
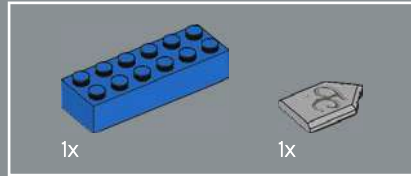
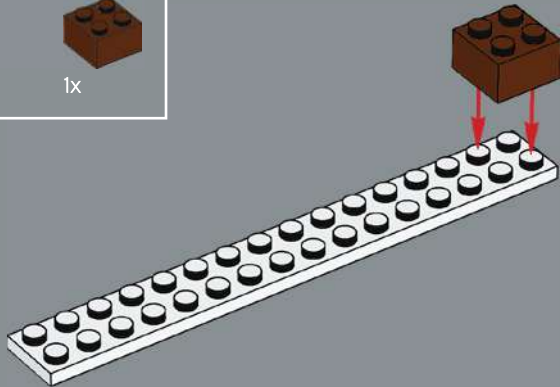
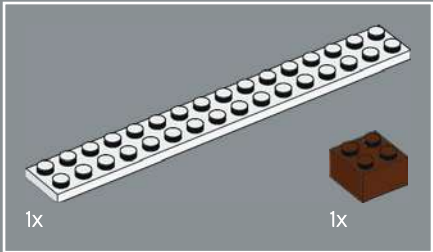
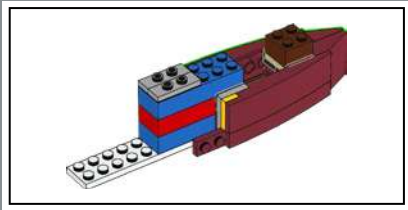
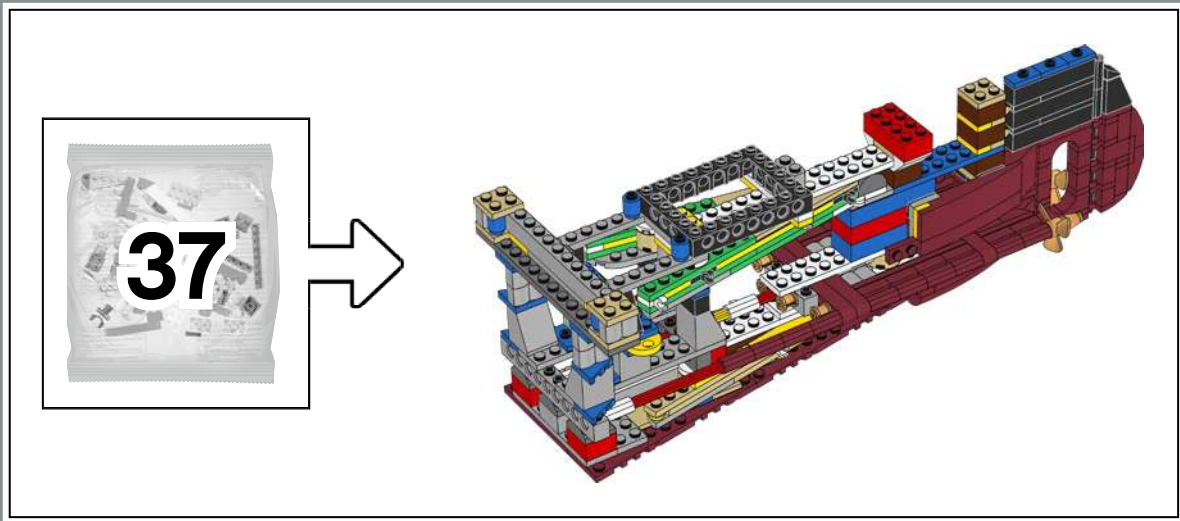



4x

179

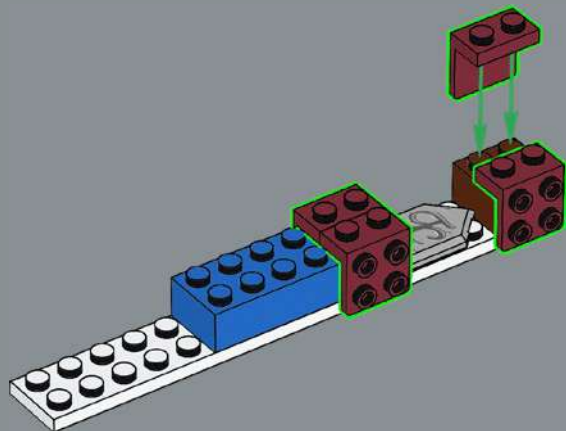

4x

180

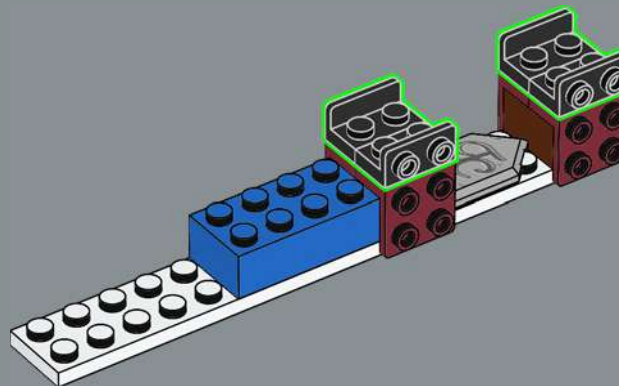

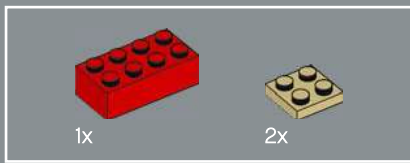

181

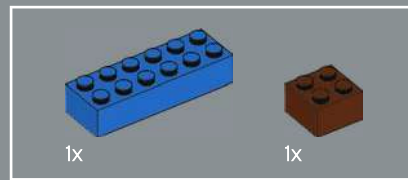
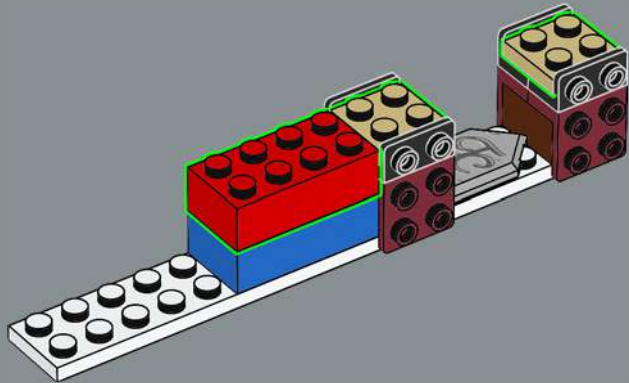

182

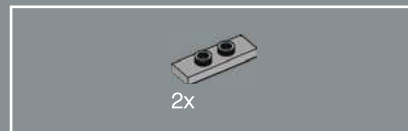
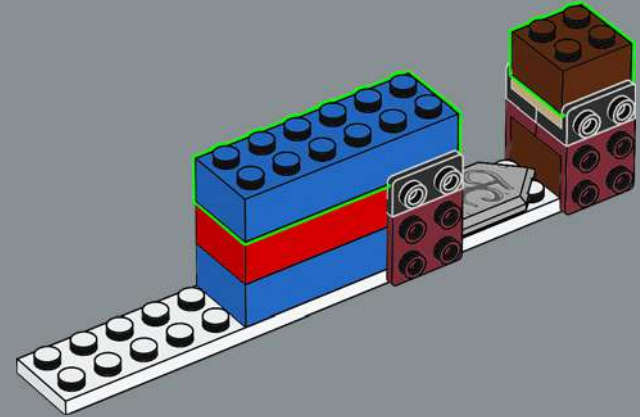

183

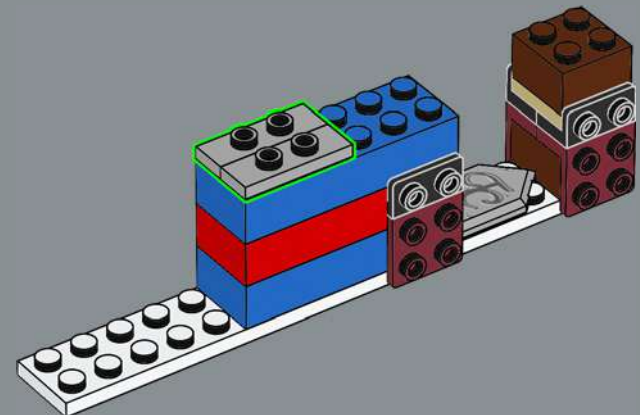

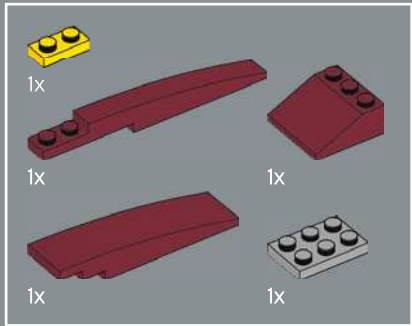

184

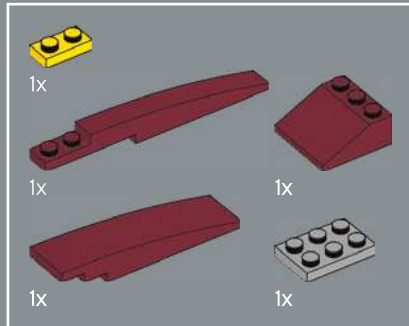
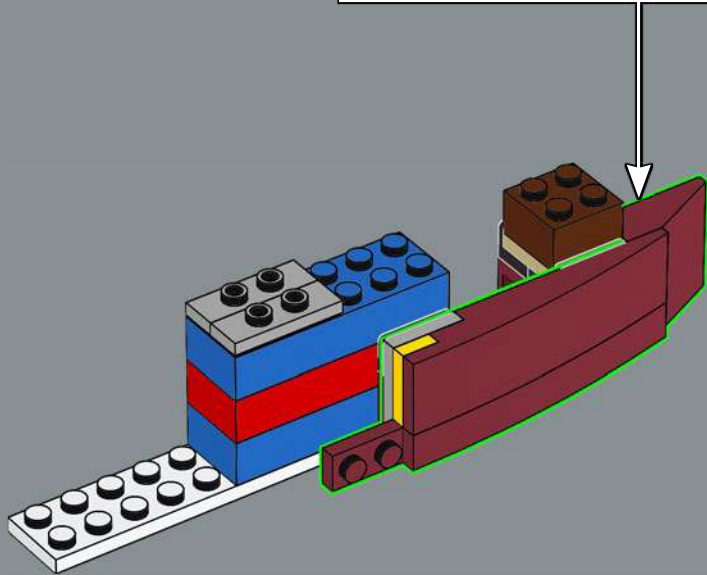
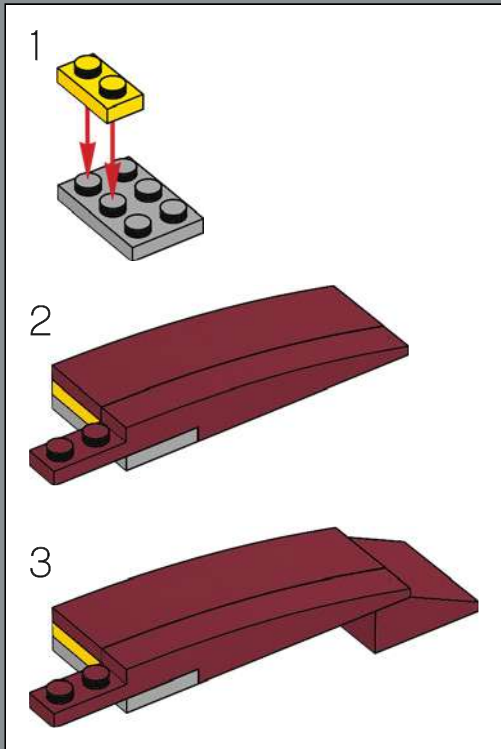

185

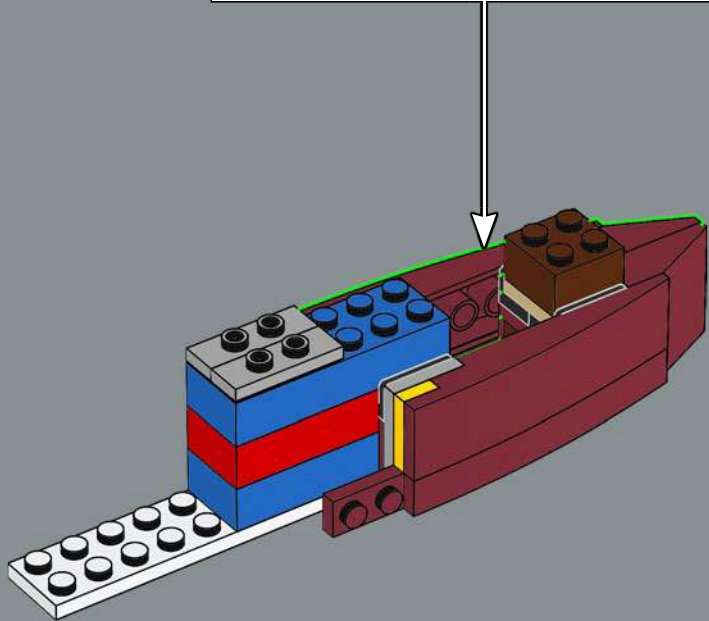
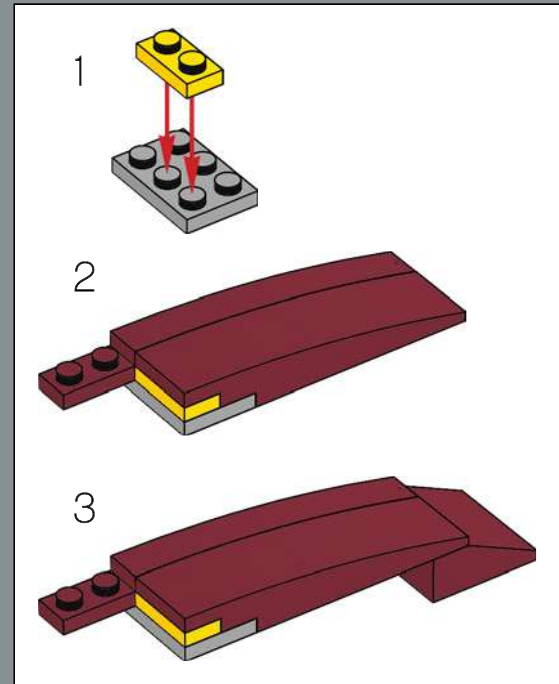

186

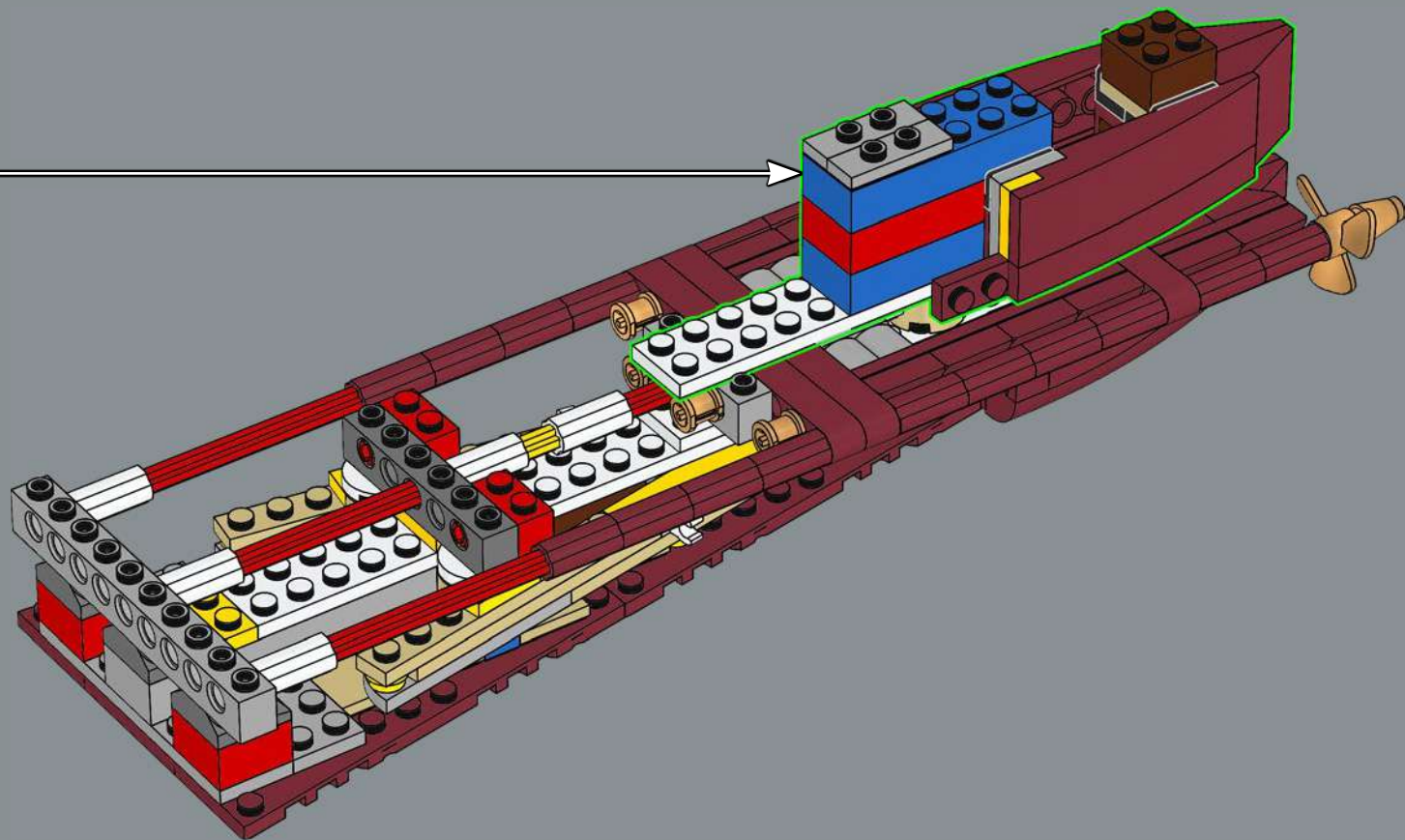

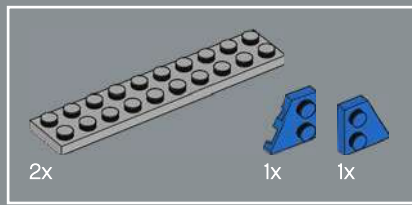

187

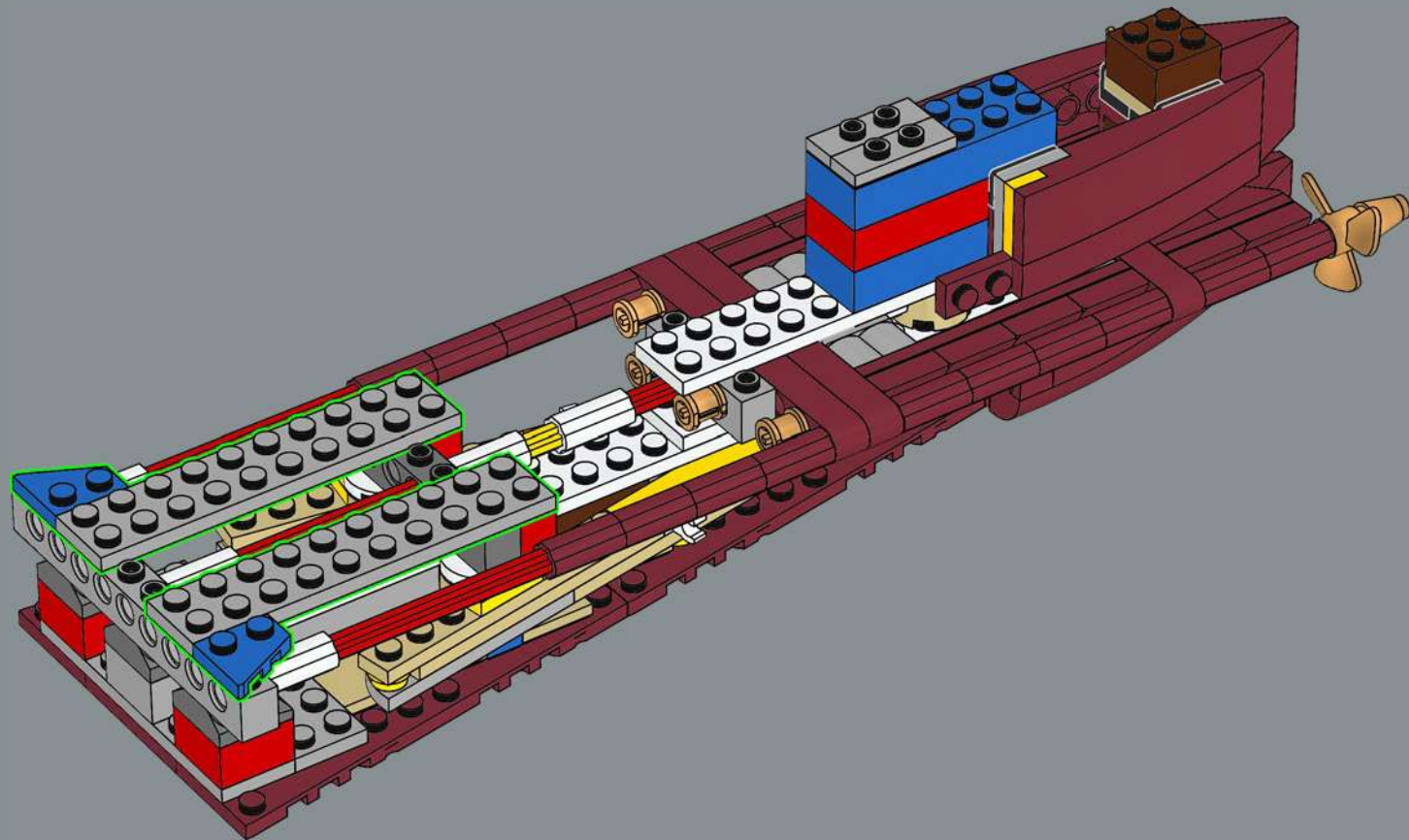

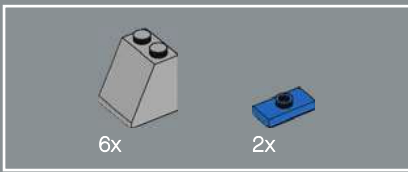

188

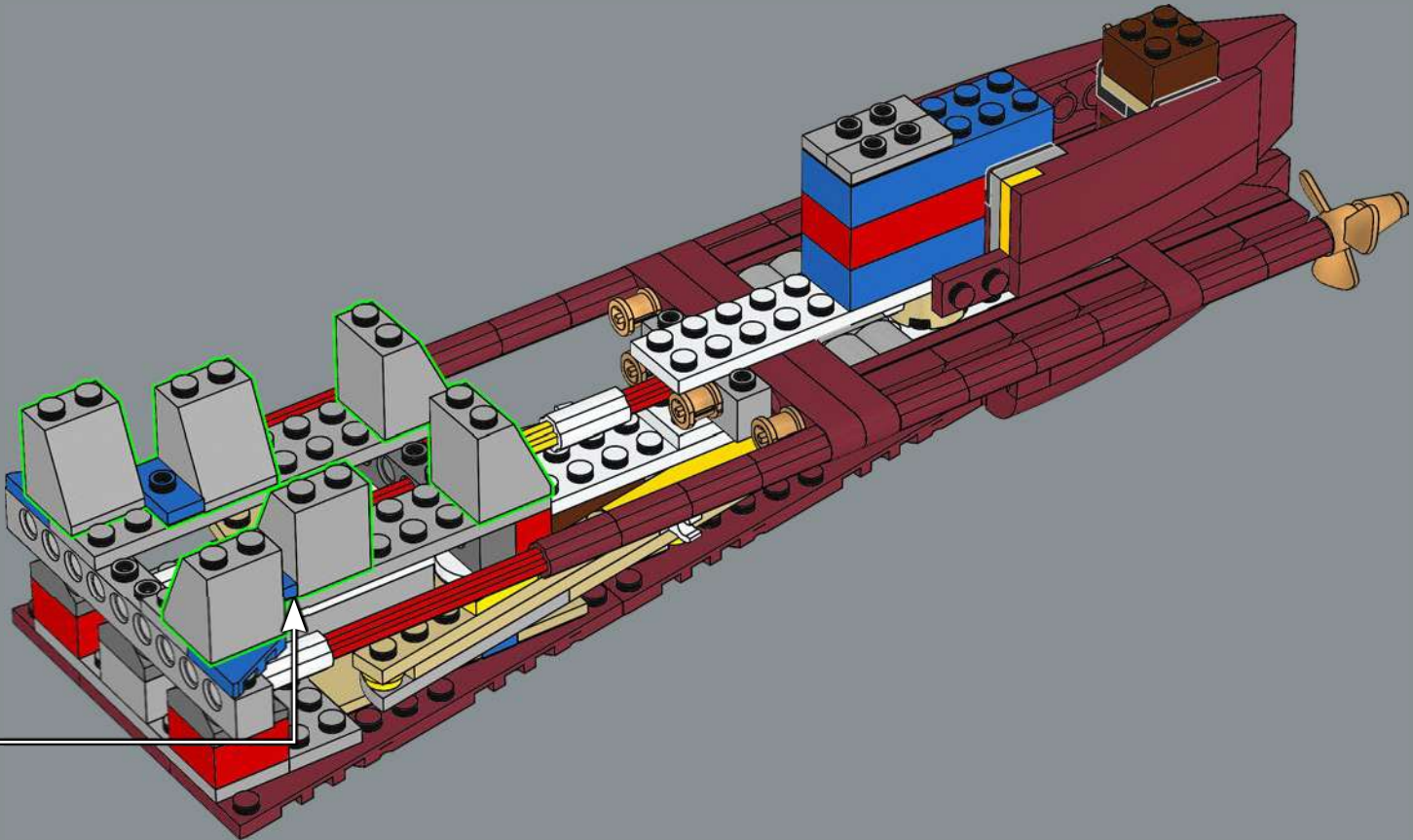

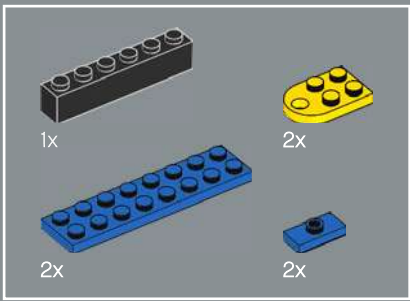

189

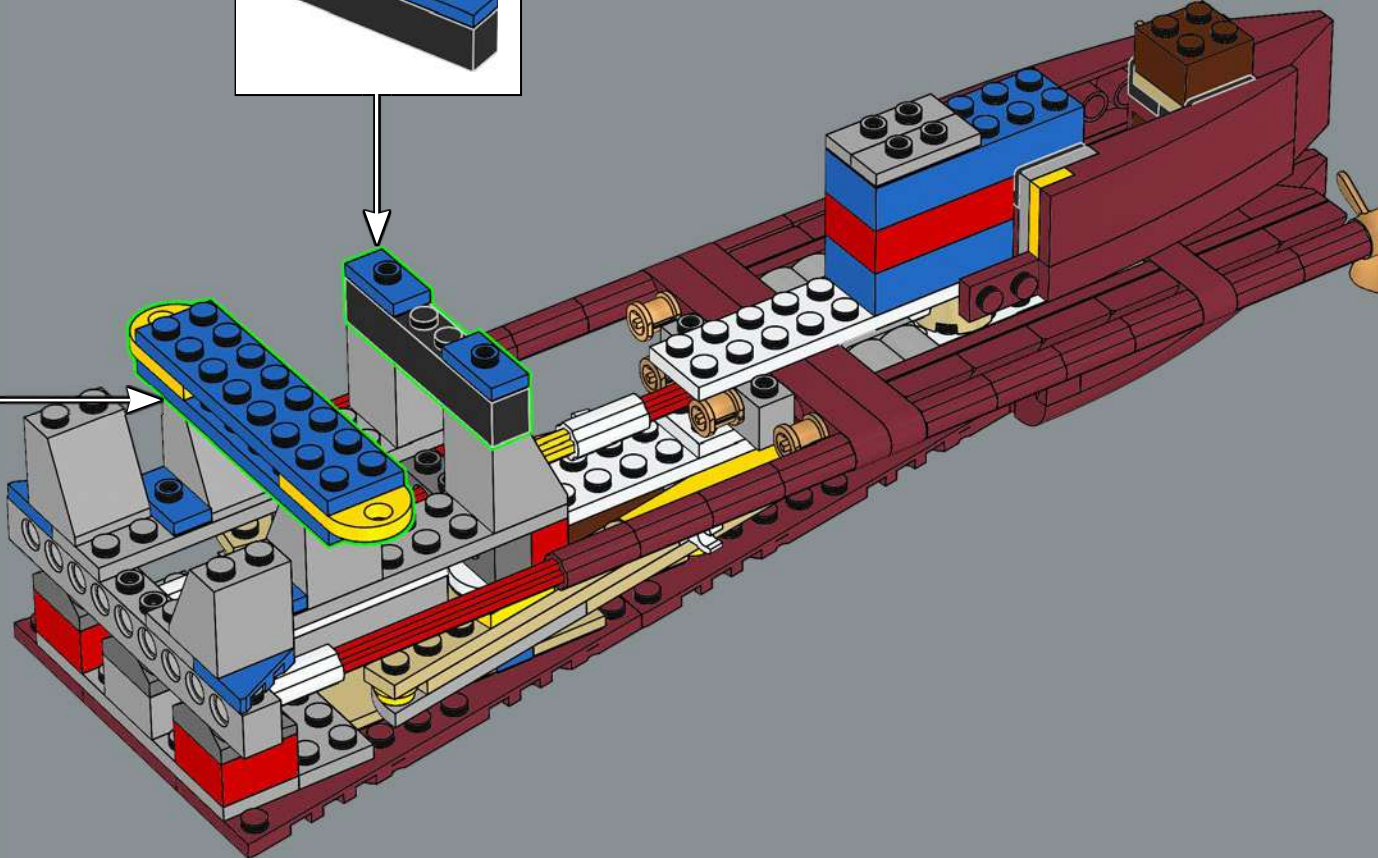
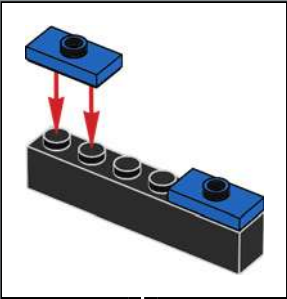
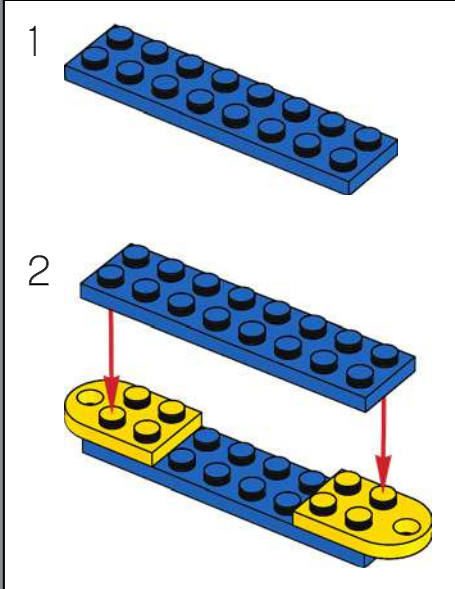

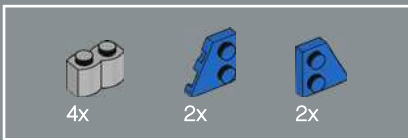

190

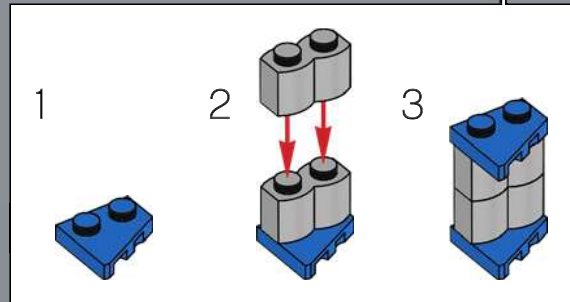
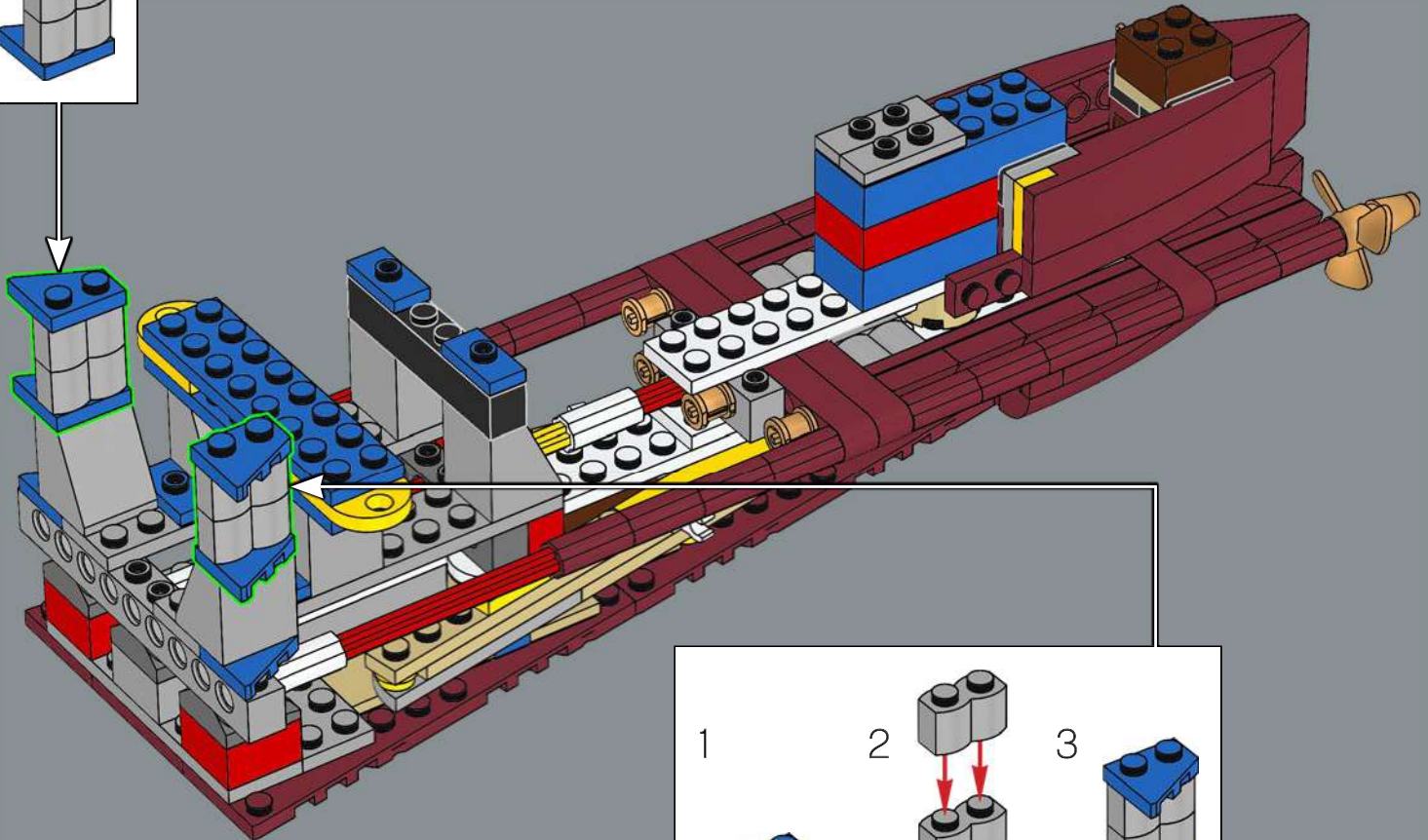
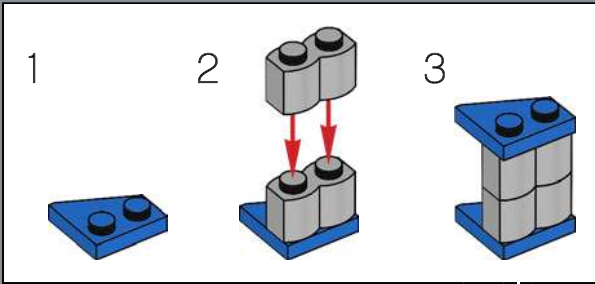

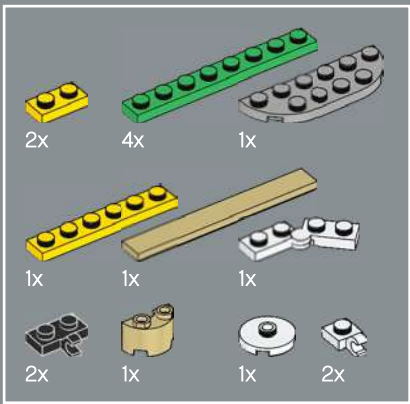

192

1

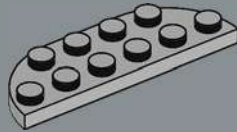

2

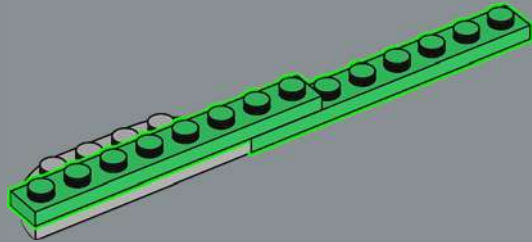

3

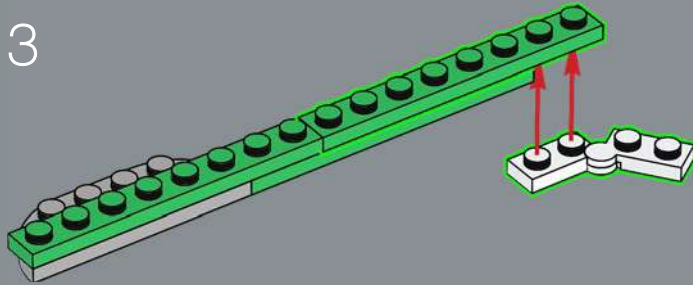

4

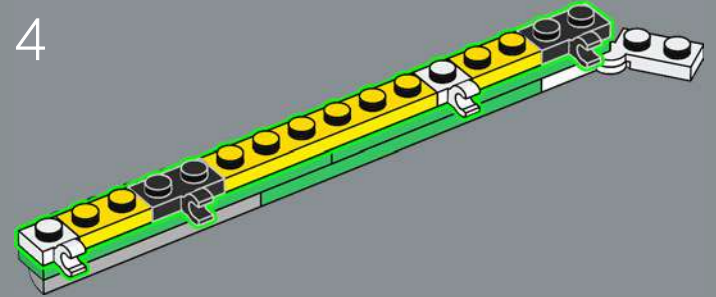

5

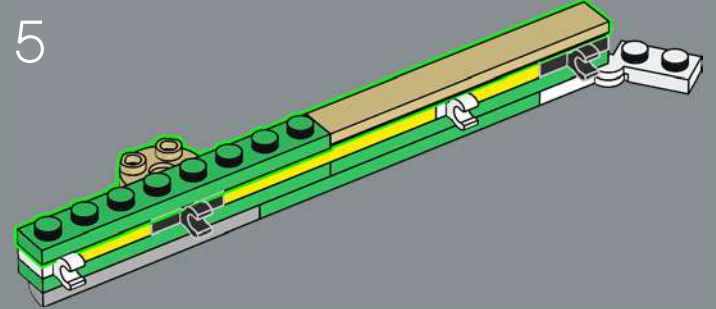

6

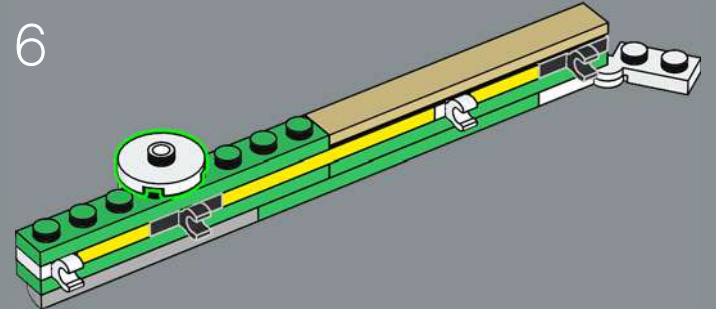

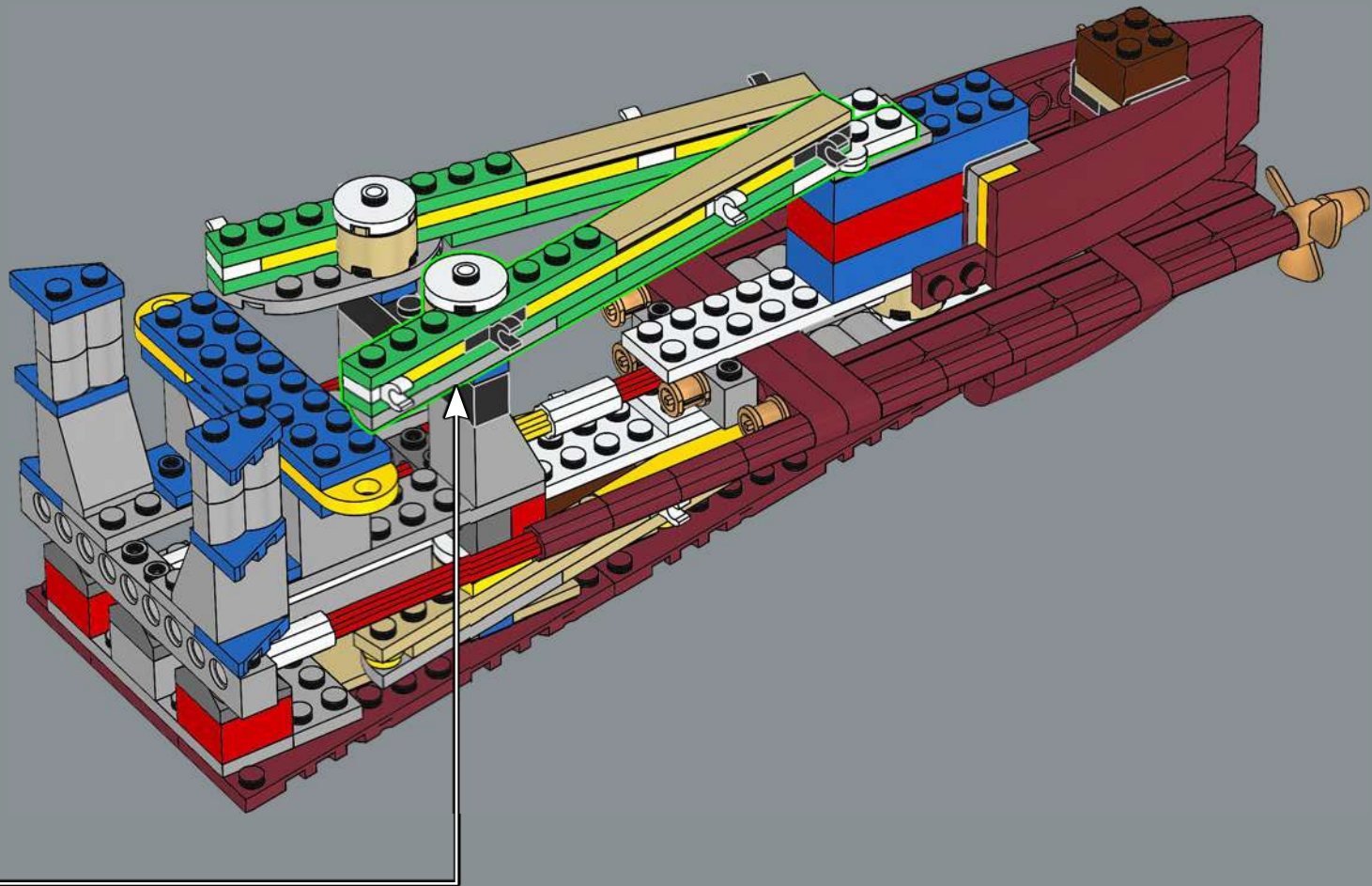

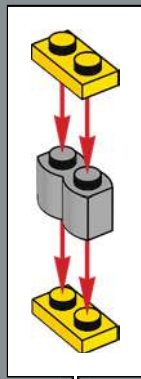
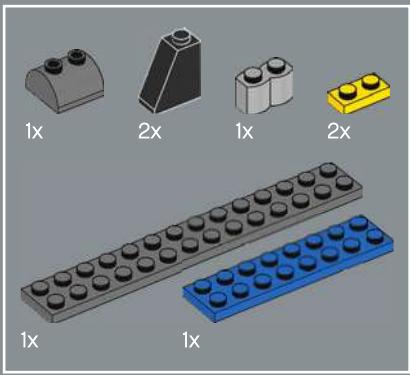

193

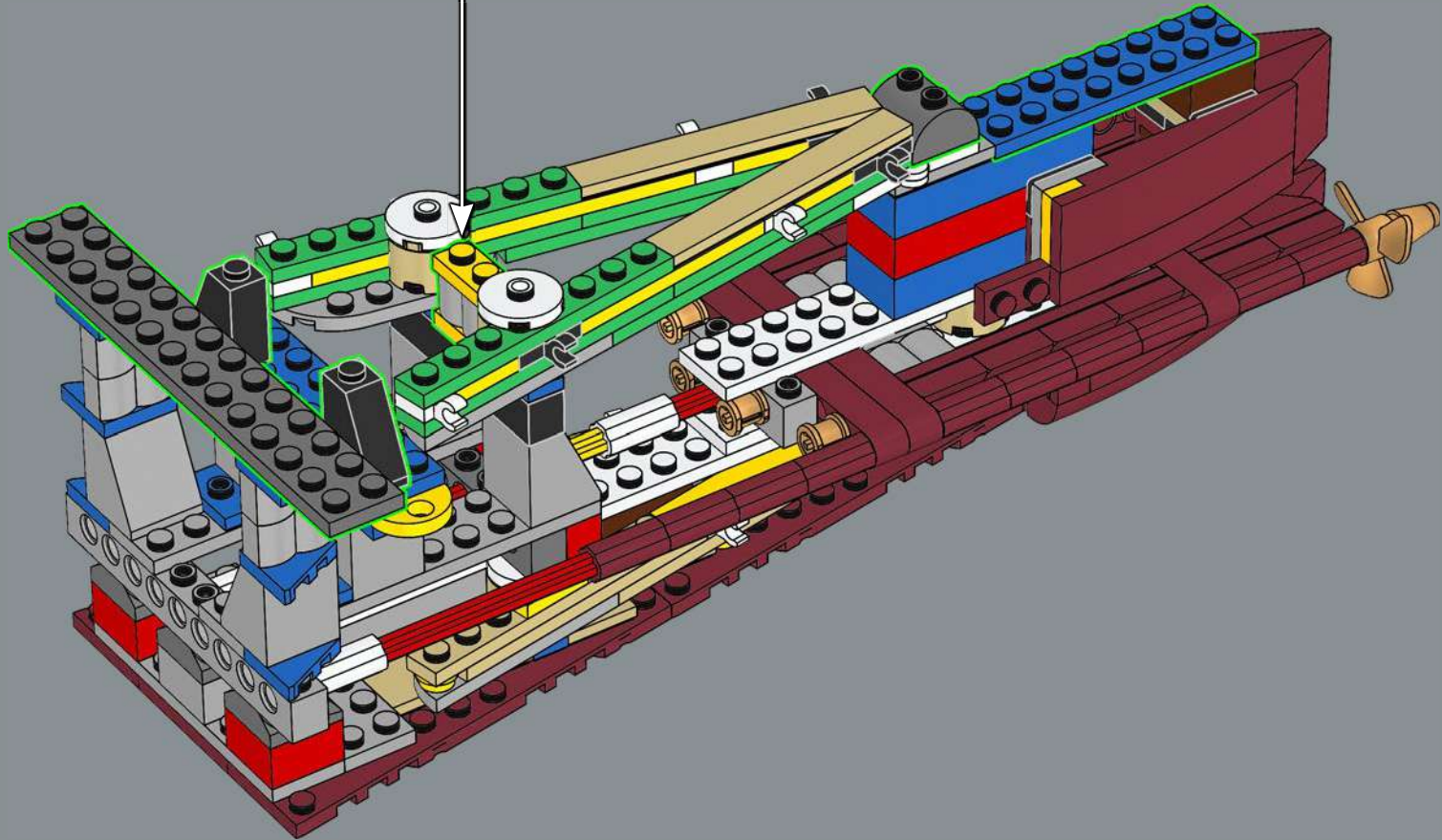

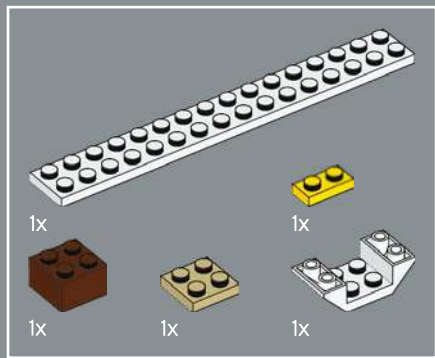

194

1



2

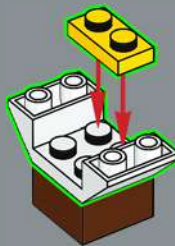

3

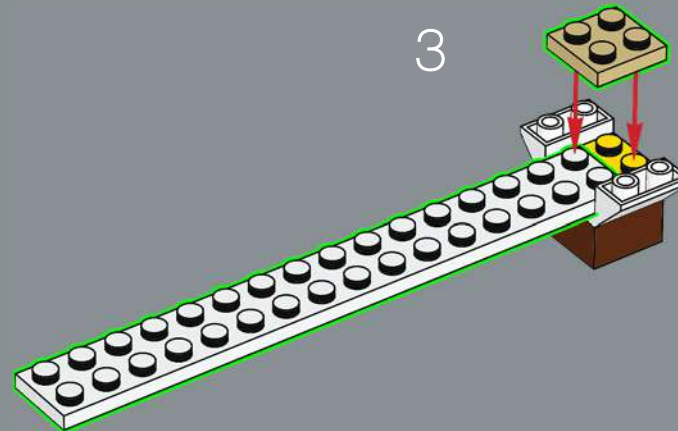

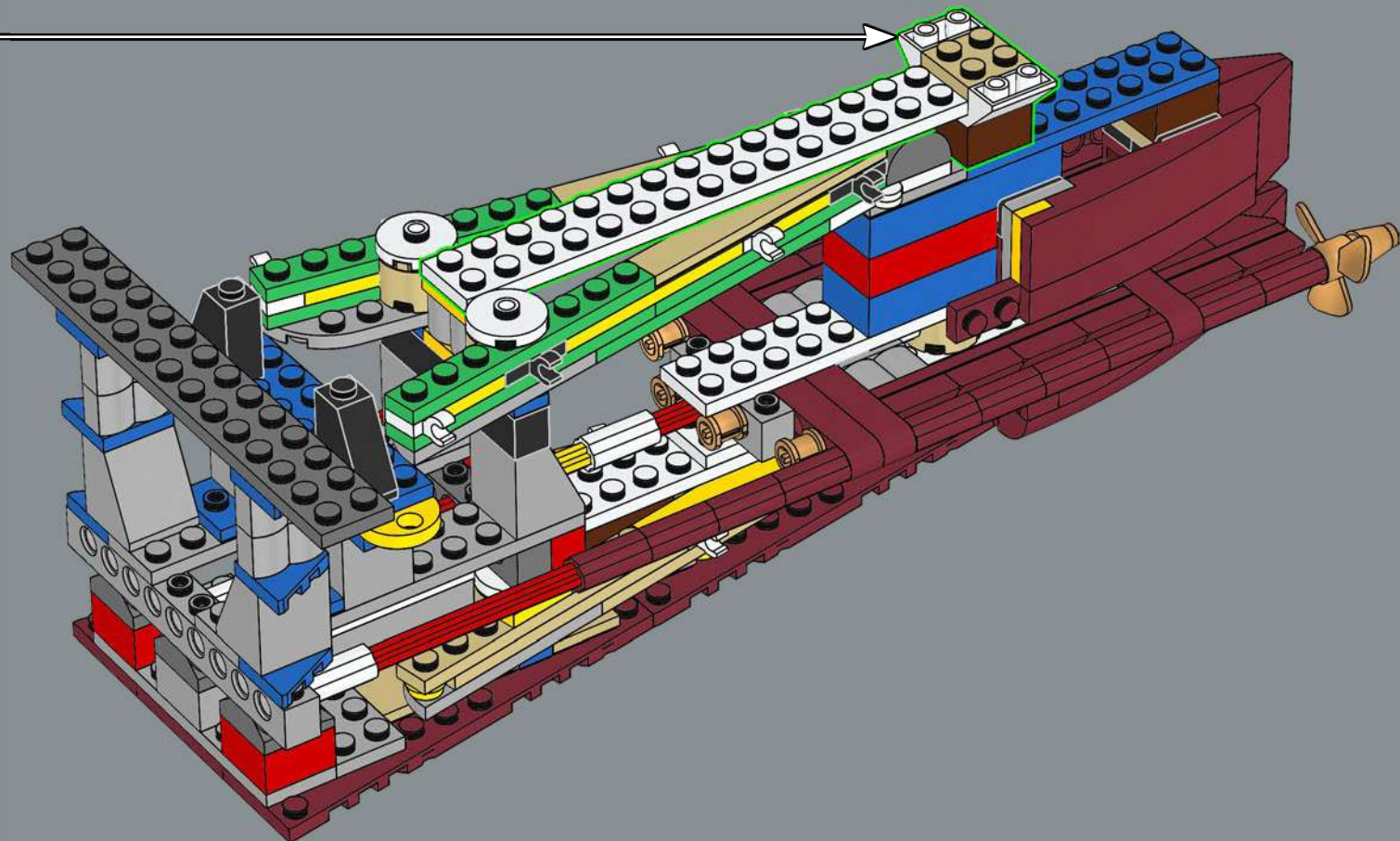

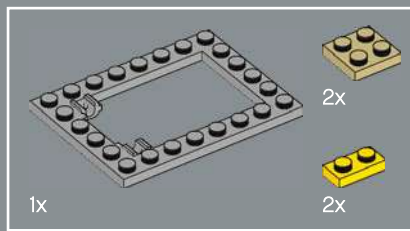

195

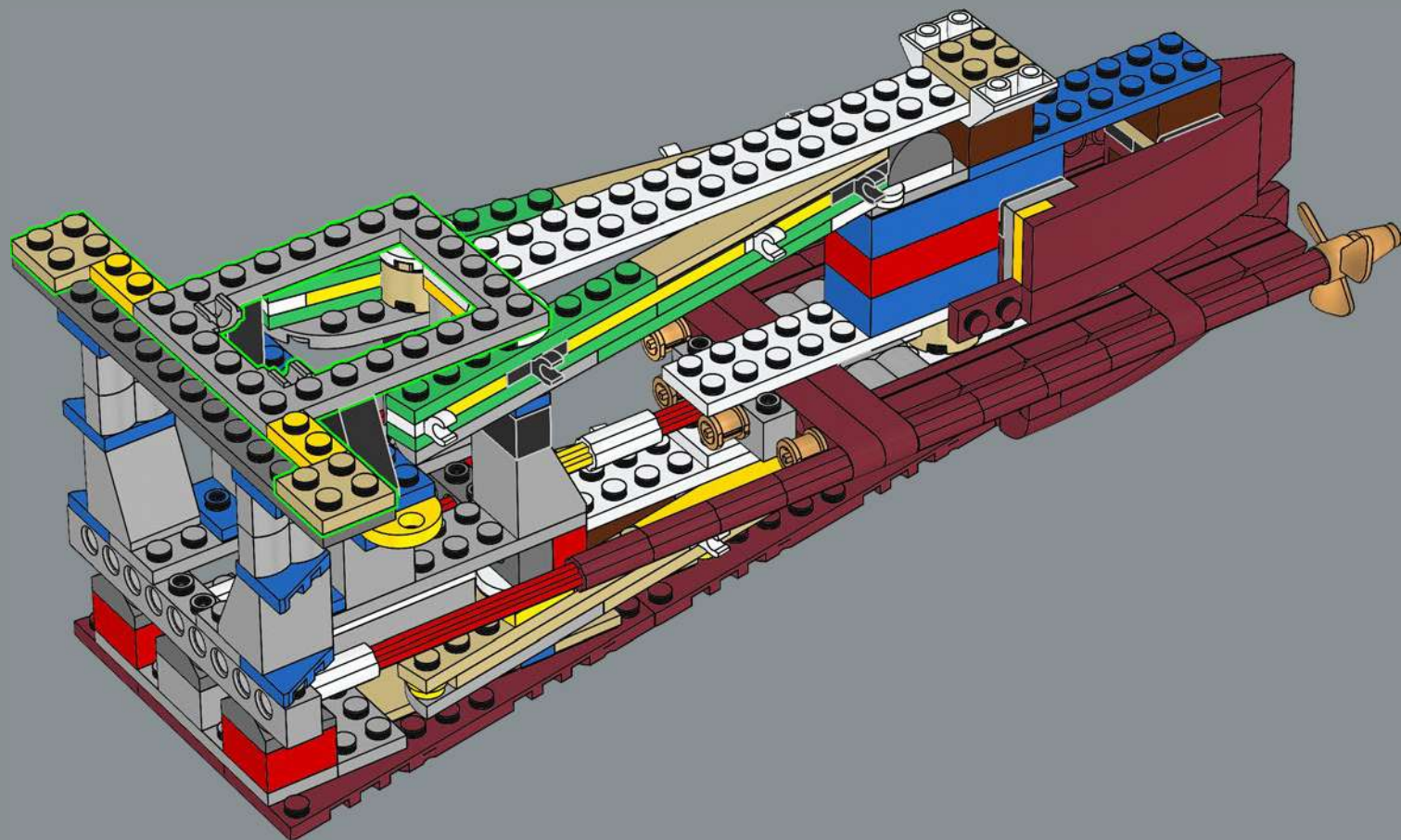

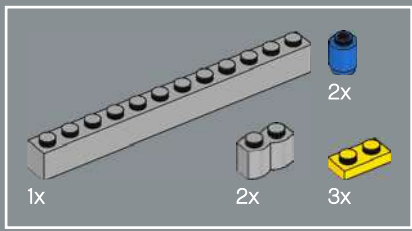

196

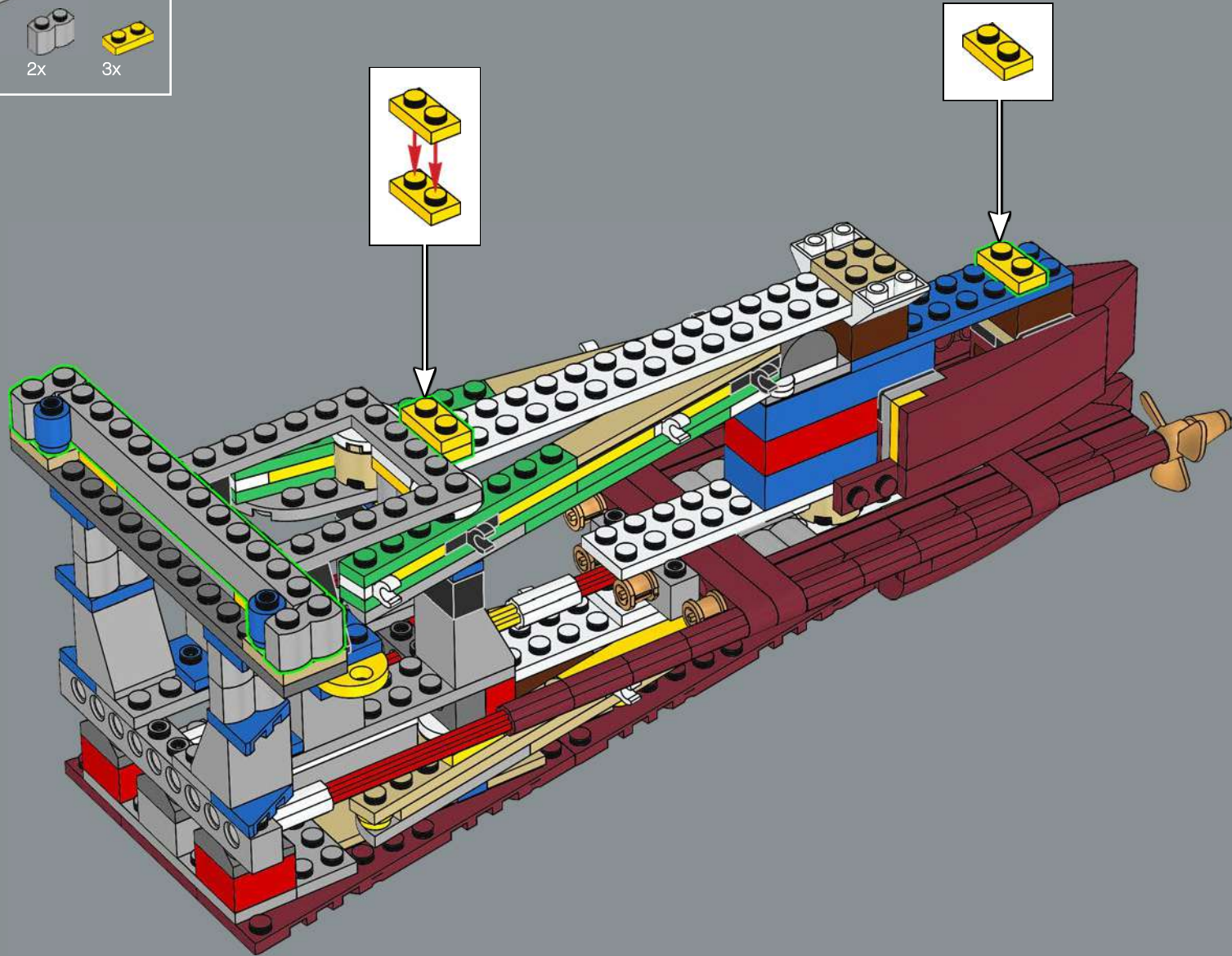

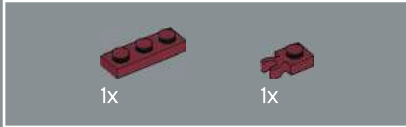
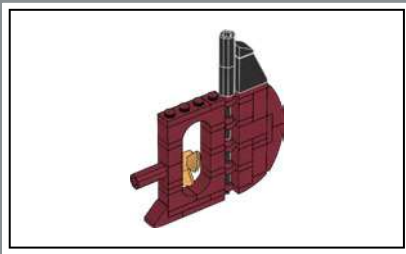

197

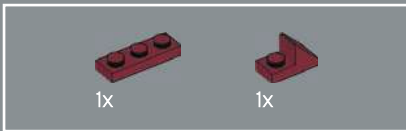
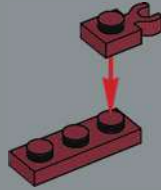

198

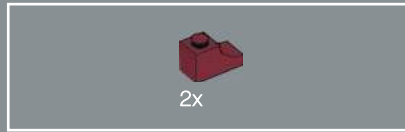
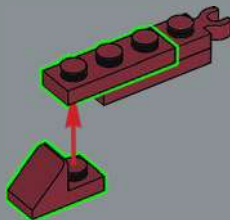

199

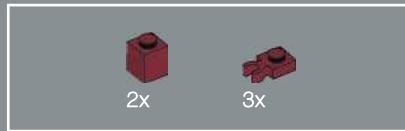
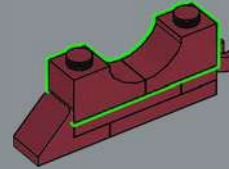

200

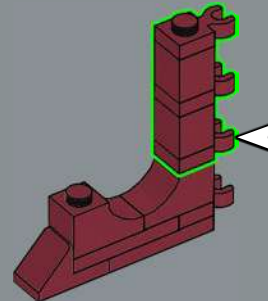
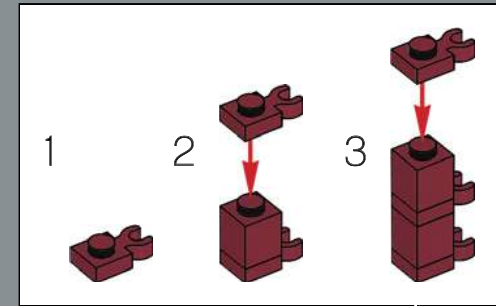

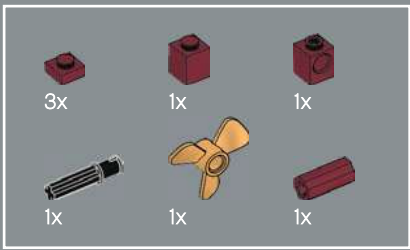

201

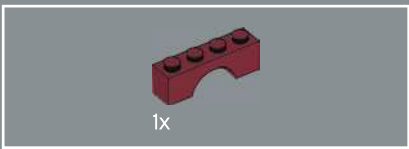
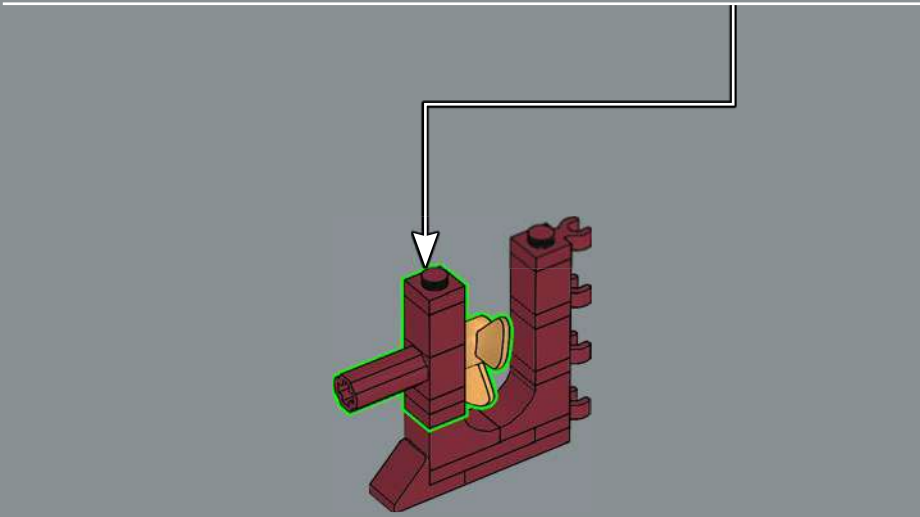
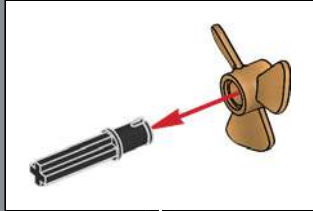
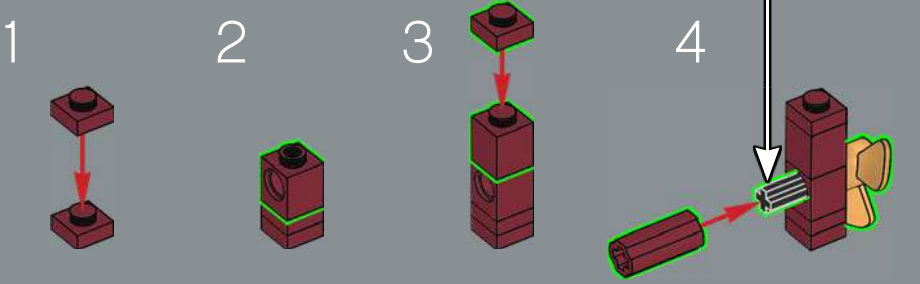

202

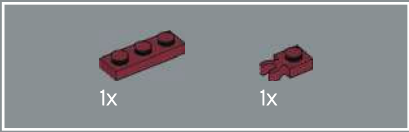
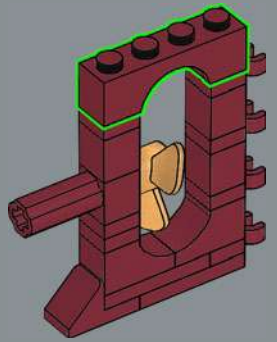

203

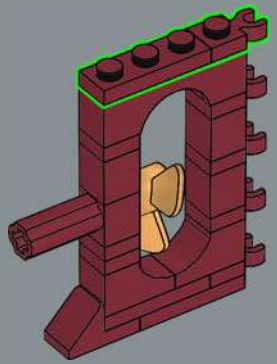

204

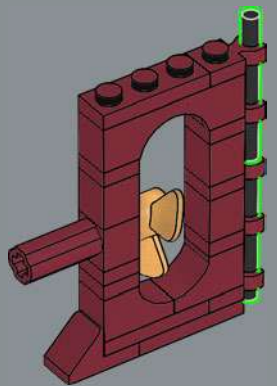

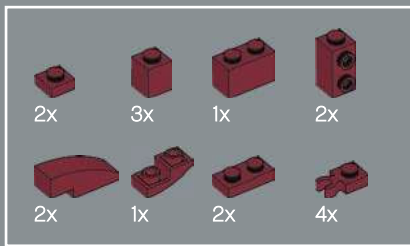

205

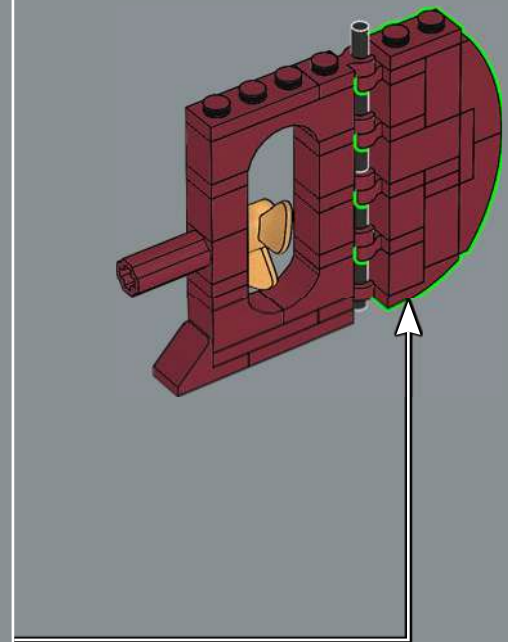
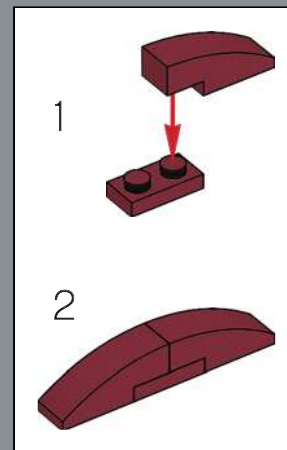
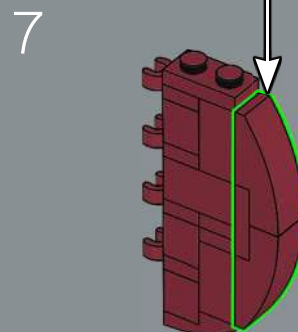
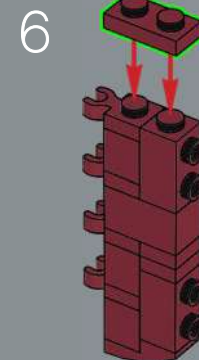
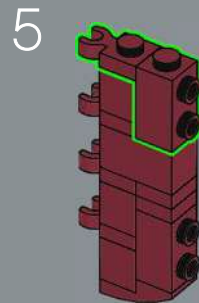
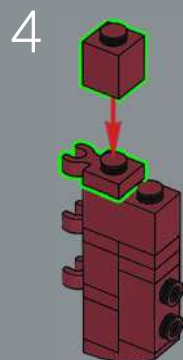
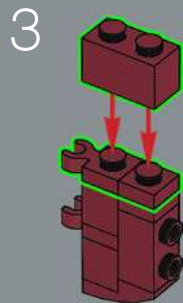
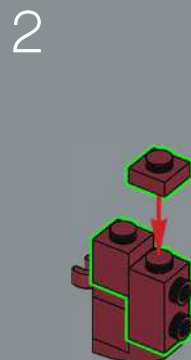
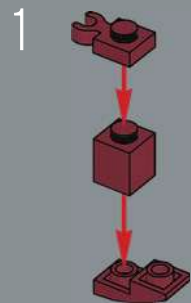

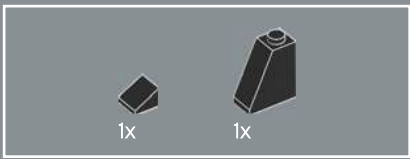

206

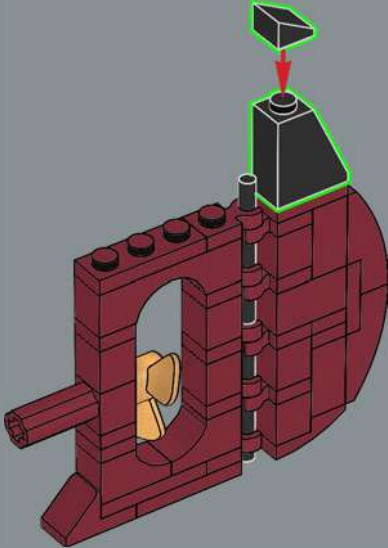

207

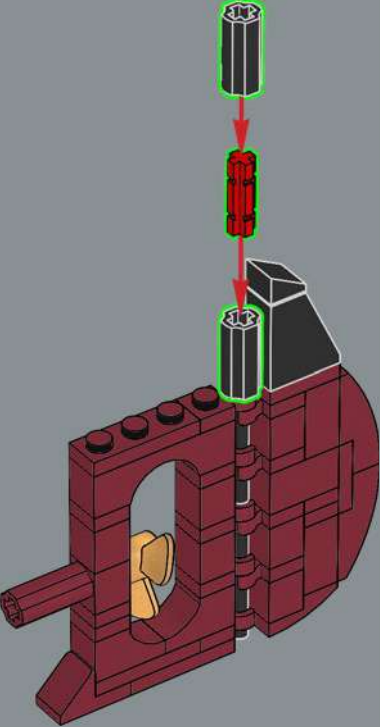

The ship's rudder was so large at 24 meters (78.8 ft.) high, 4.65 meters (15.3 ft.) long, and weighing over 100 tonnes (110.2 US tons), it required steering engines to move it.

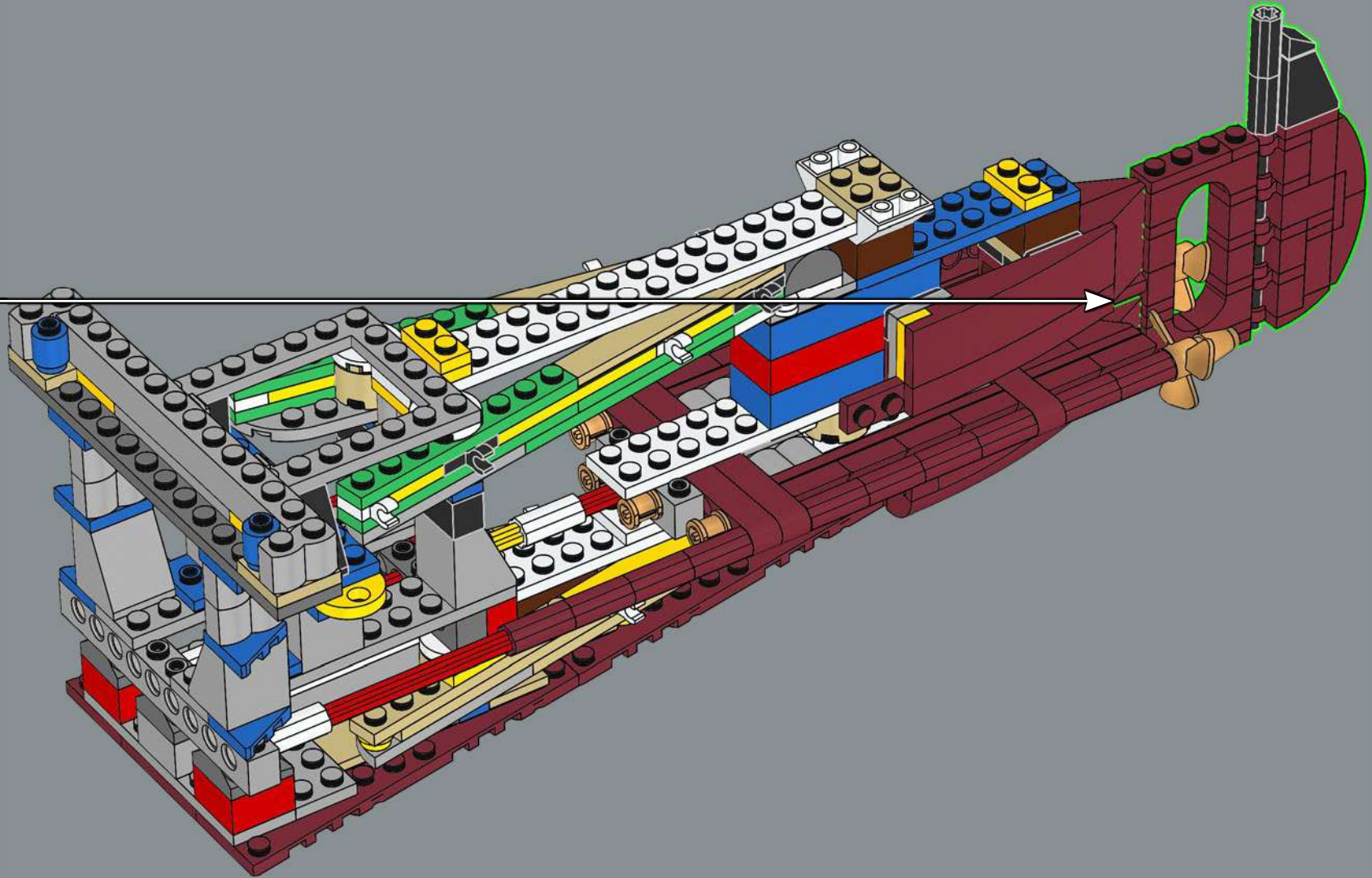

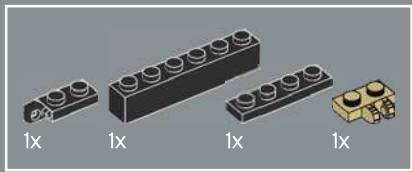

209

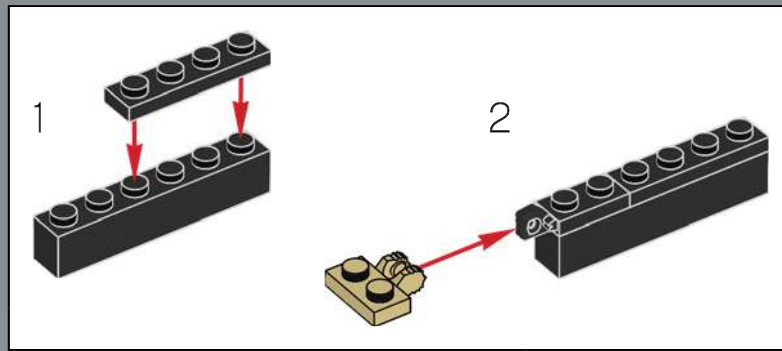

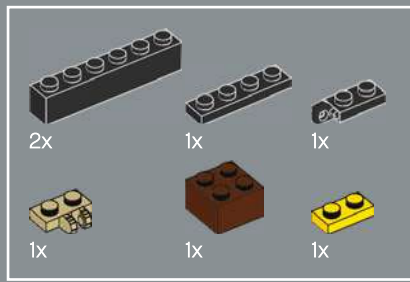

210

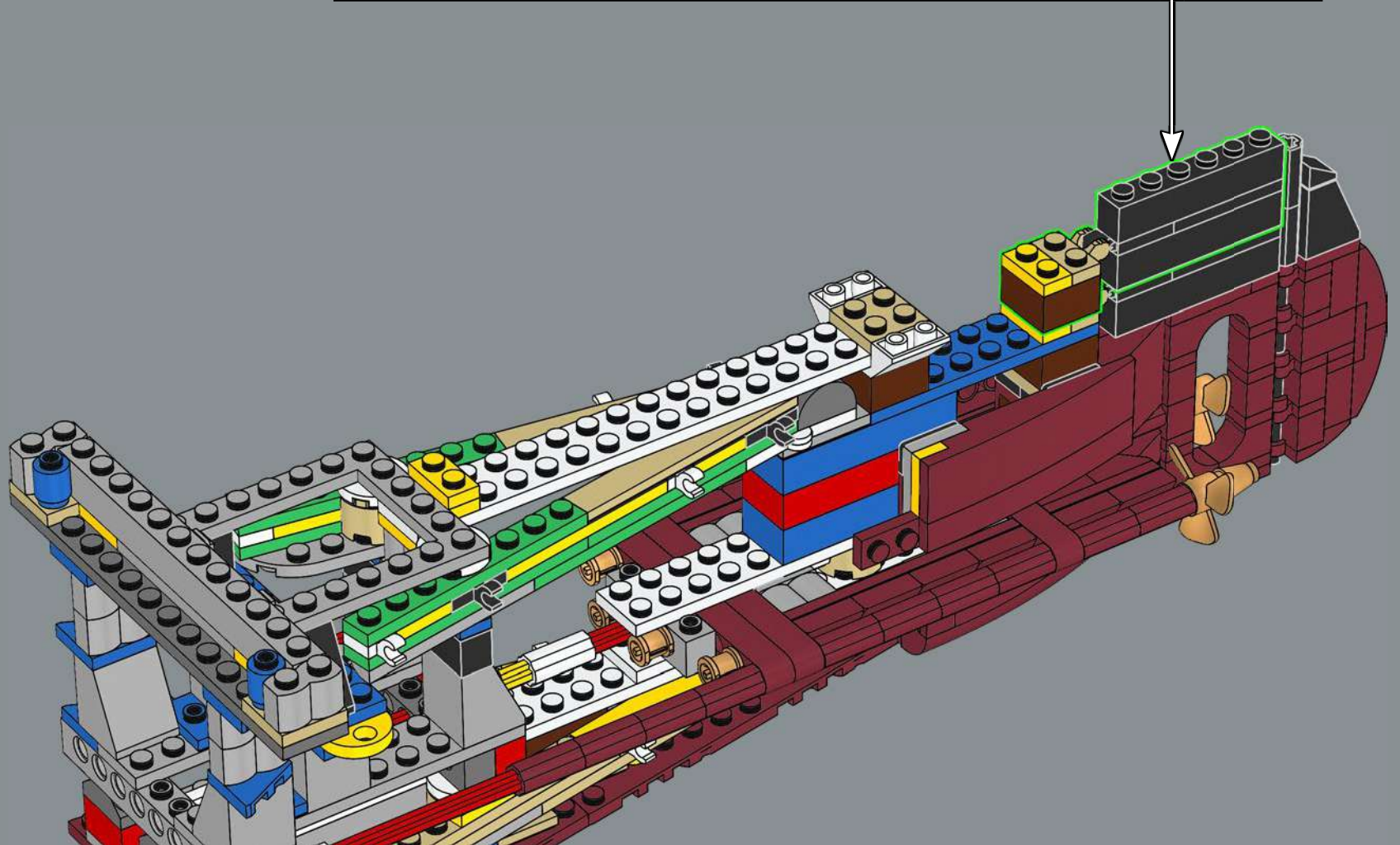
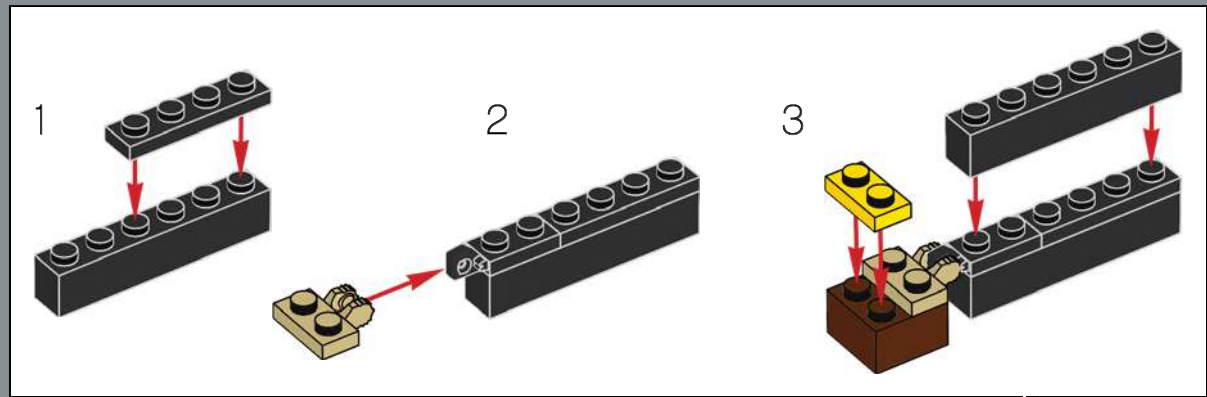

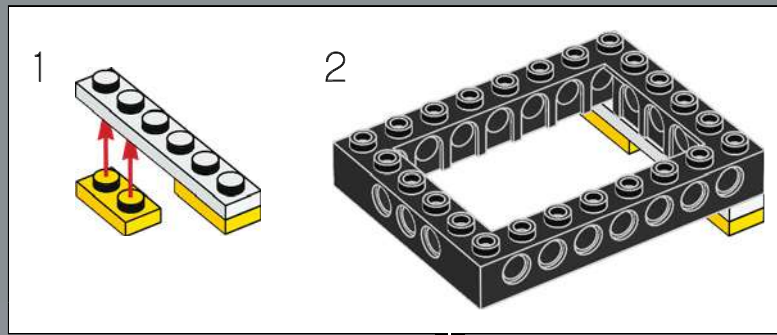
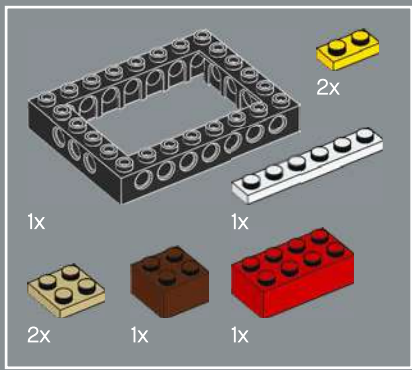

211

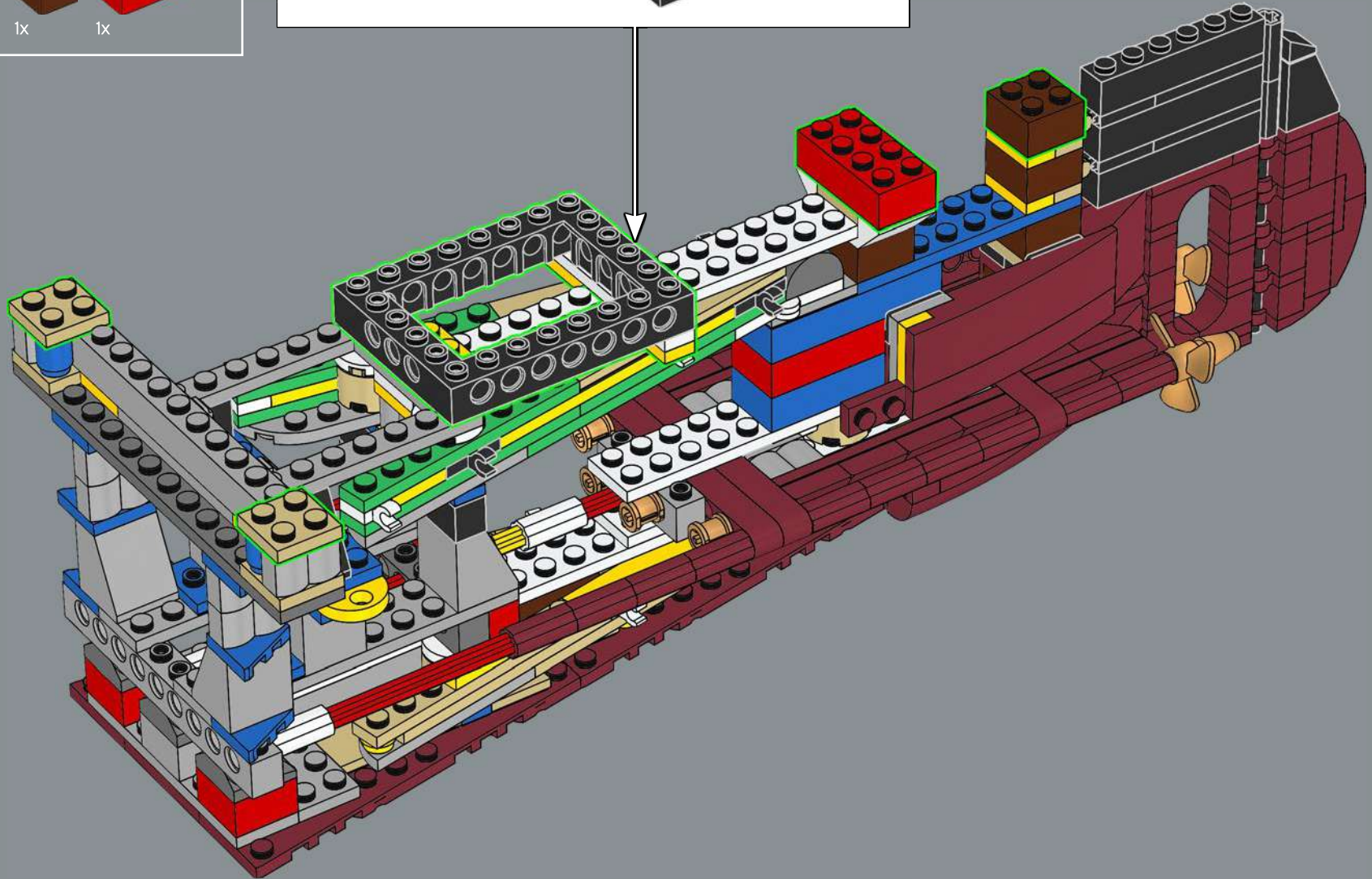

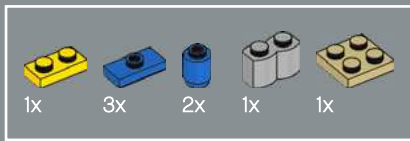

212

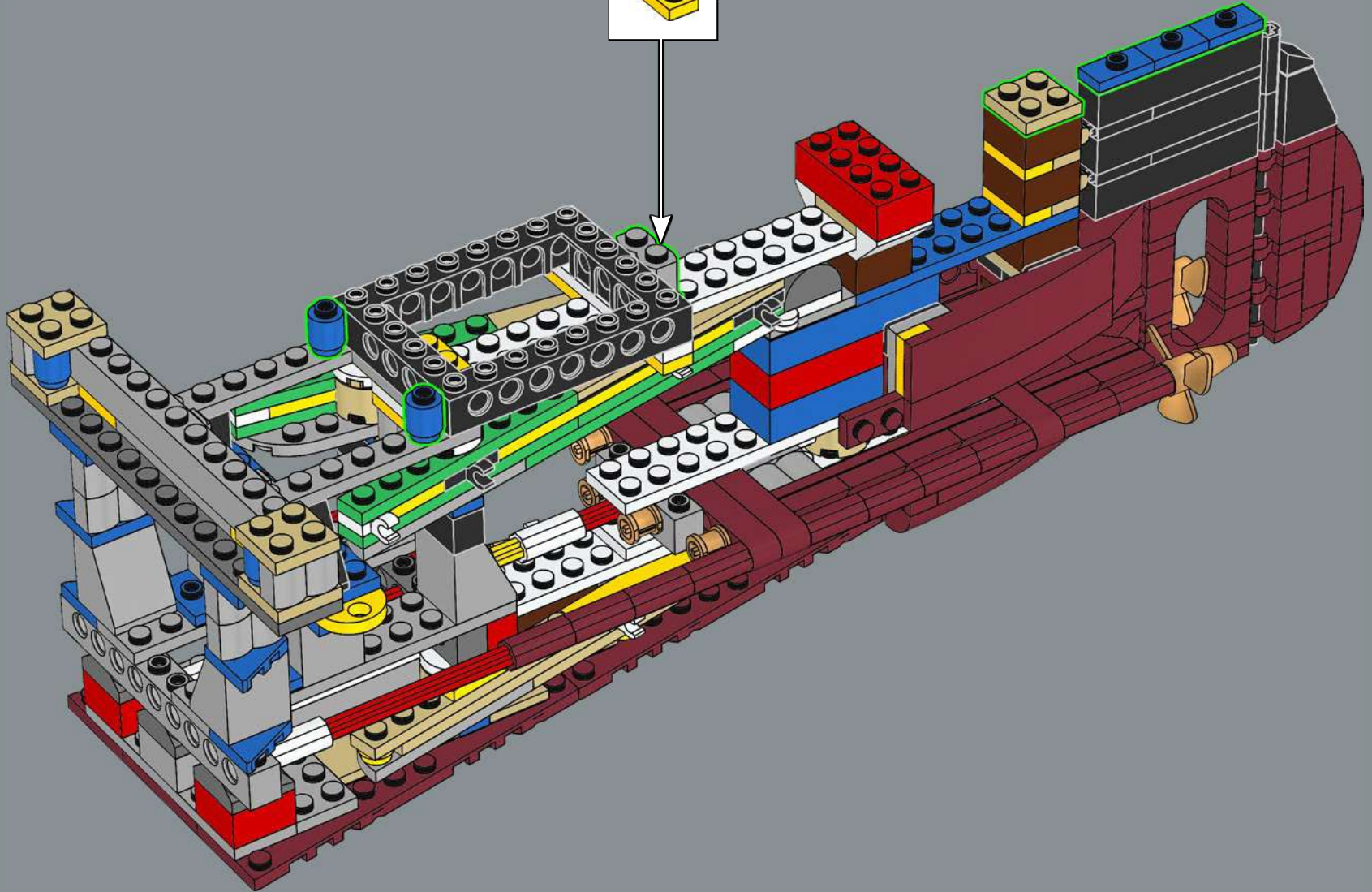
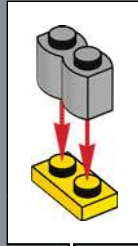

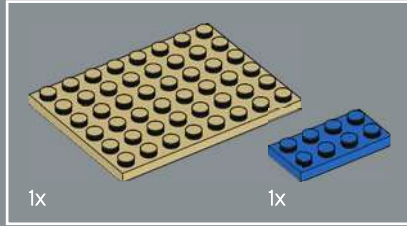
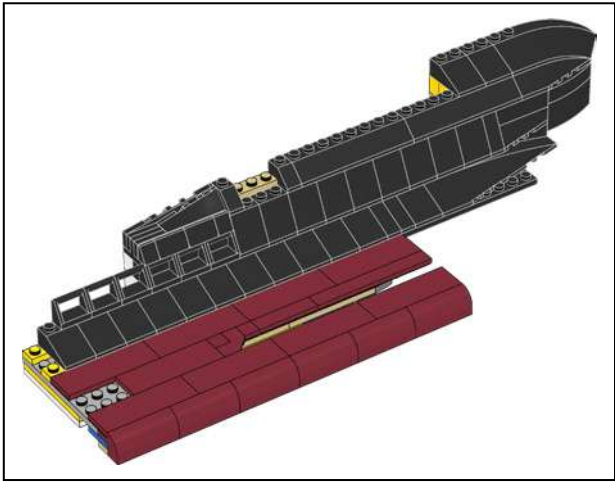
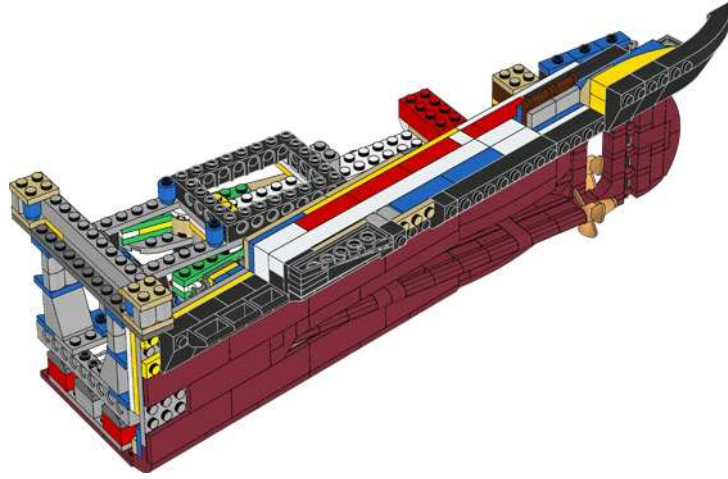
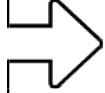

213

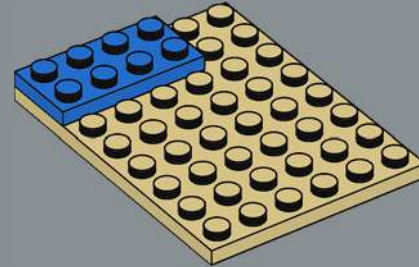

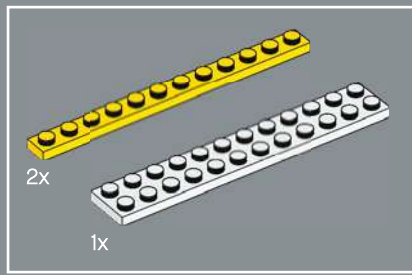

214

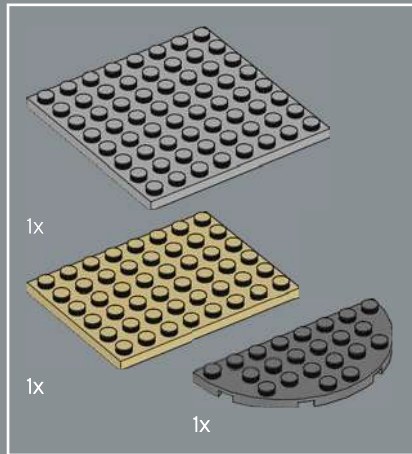
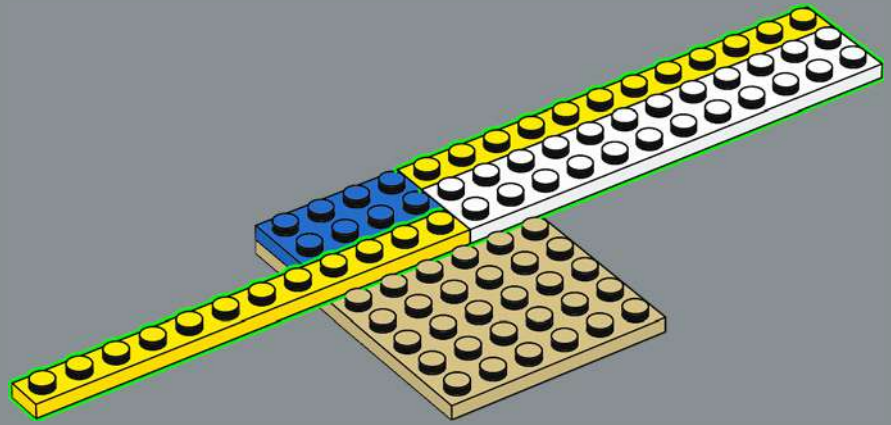

215

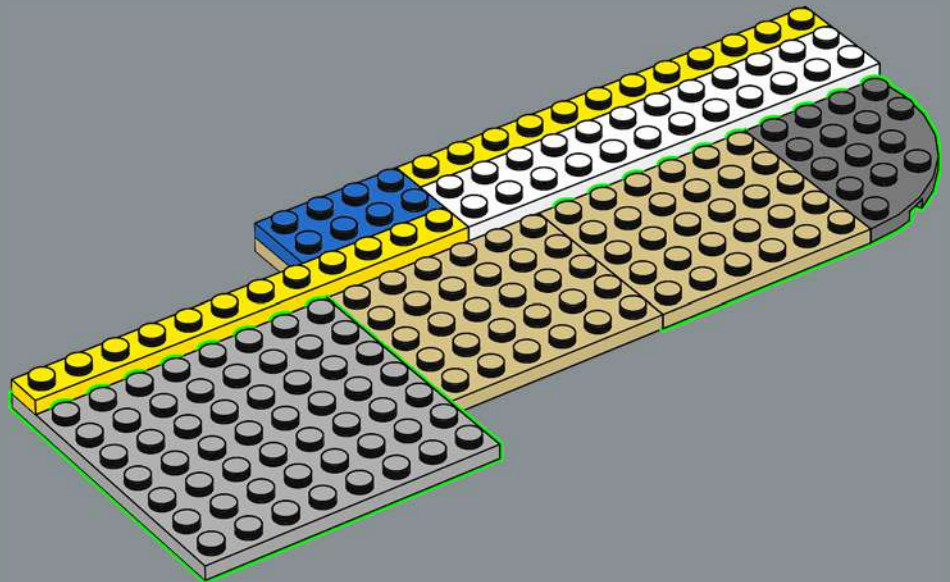

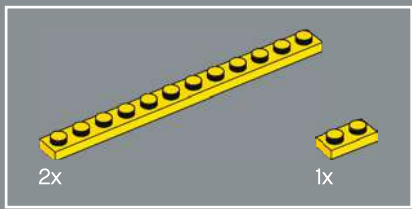

216

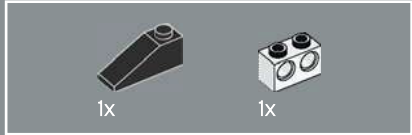
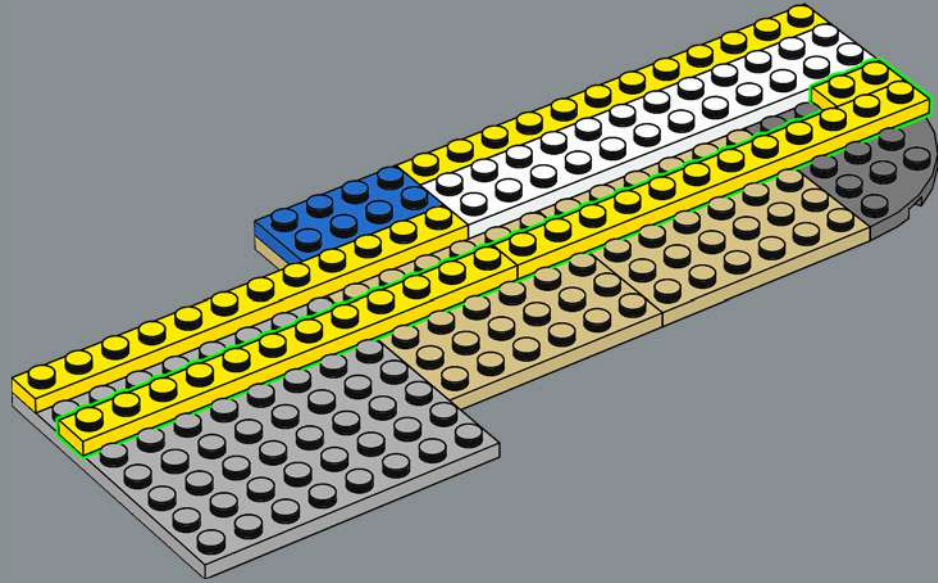

217

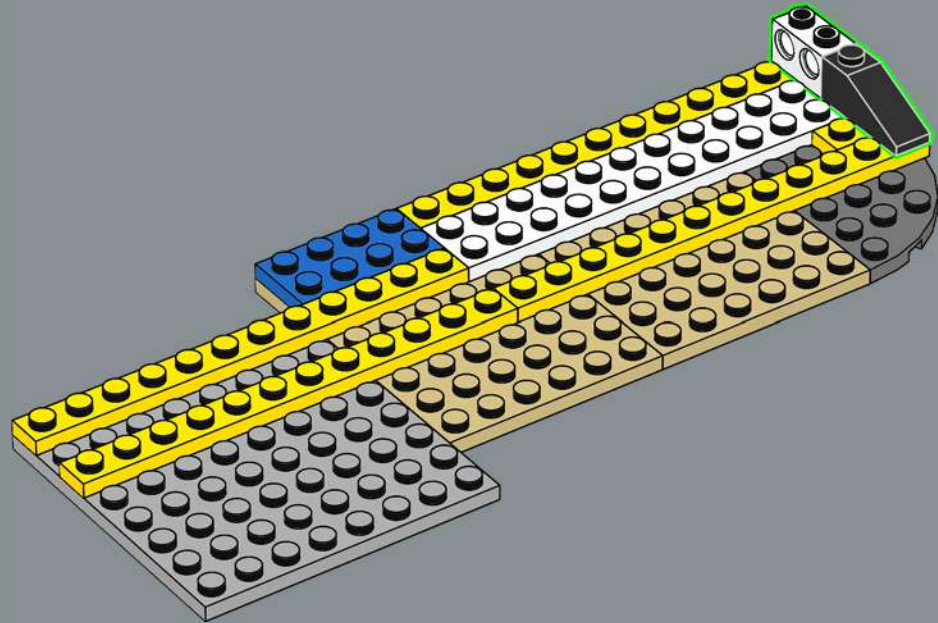

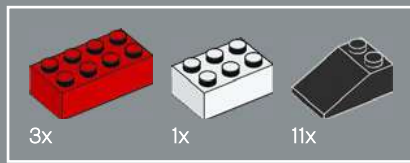

218

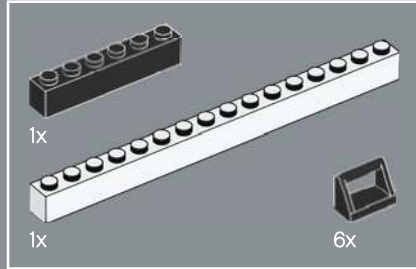
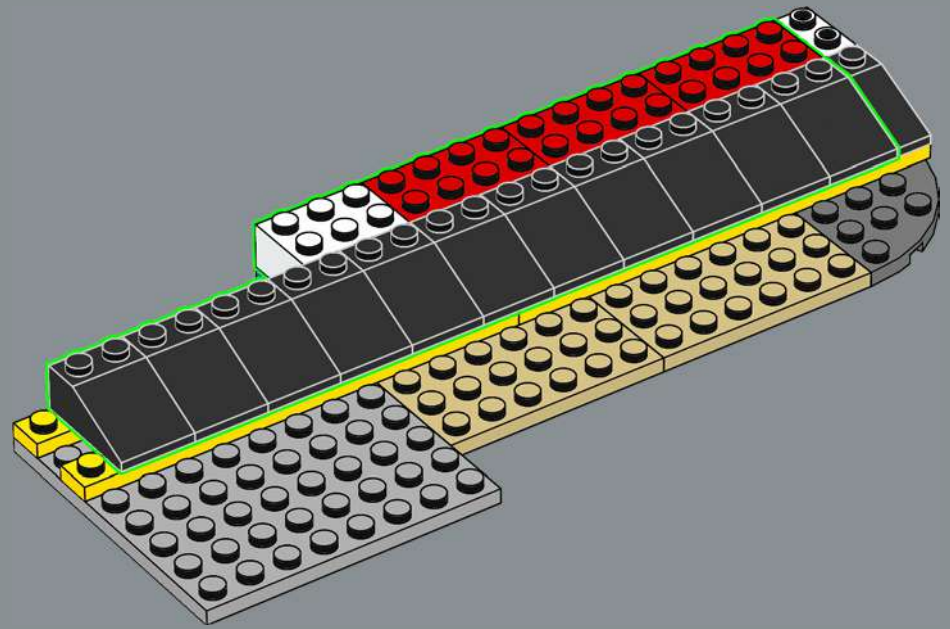

219

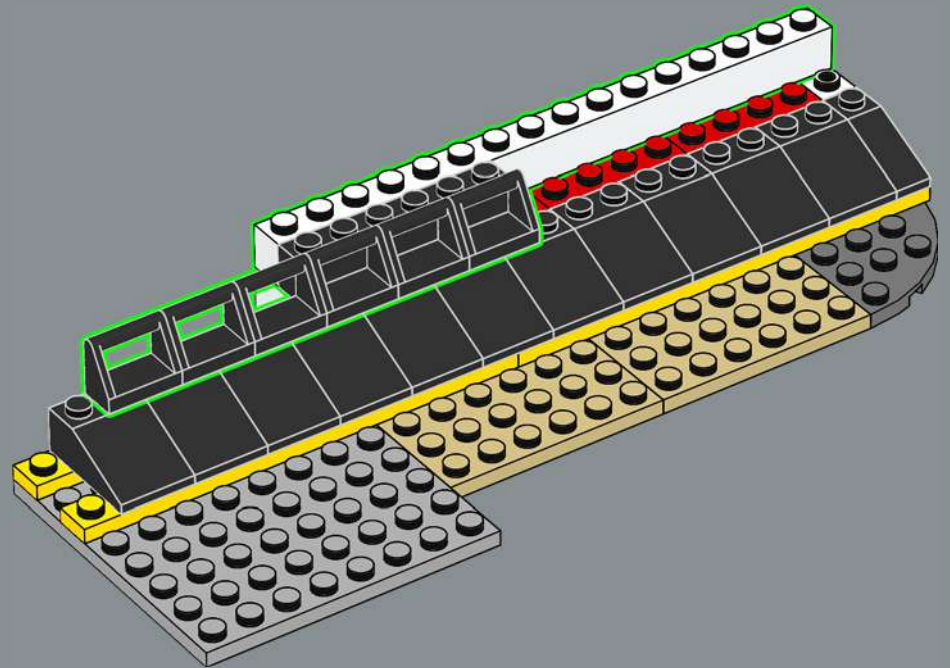

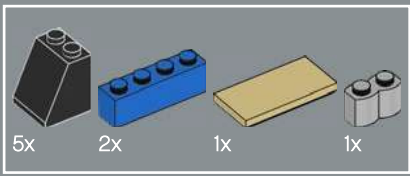

220

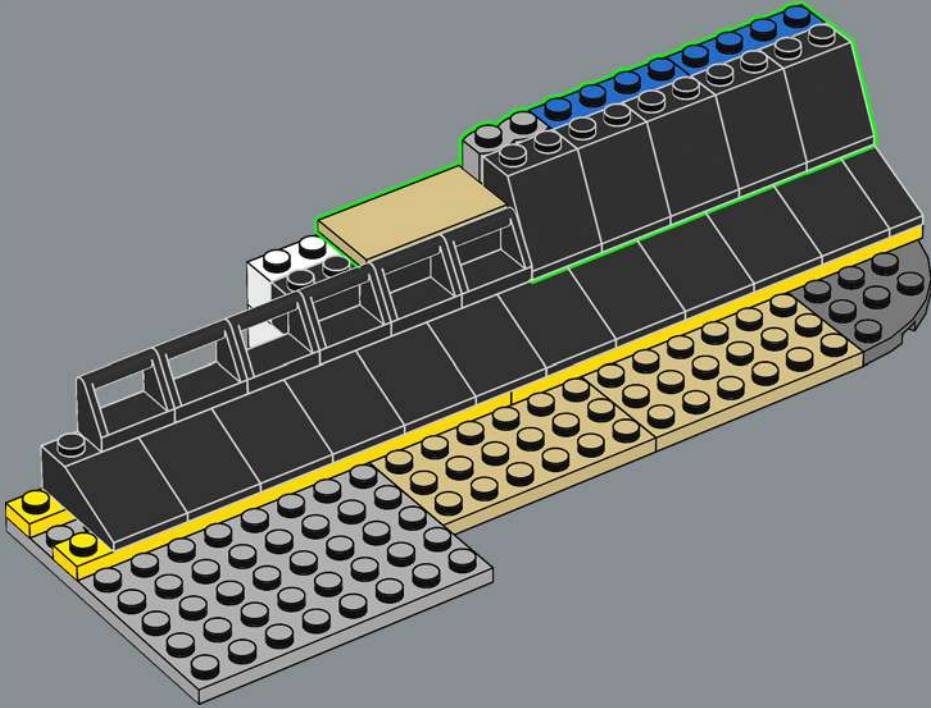

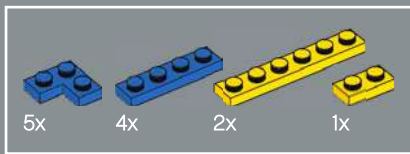

221

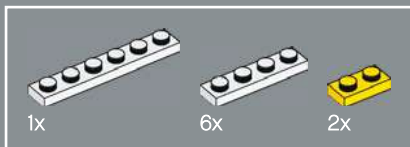
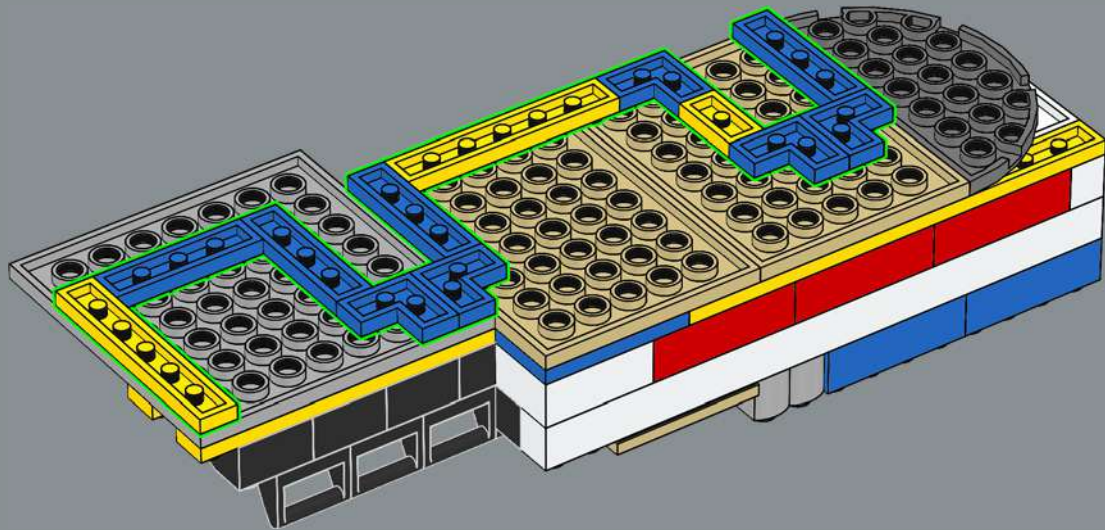

222

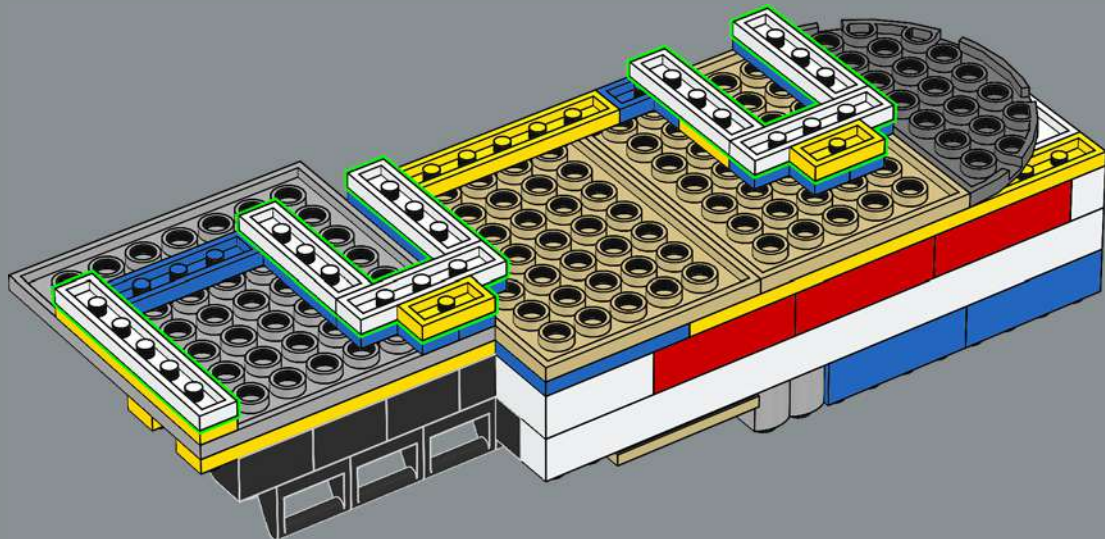

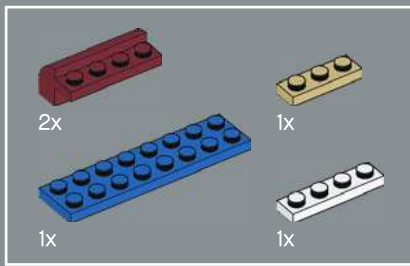

223

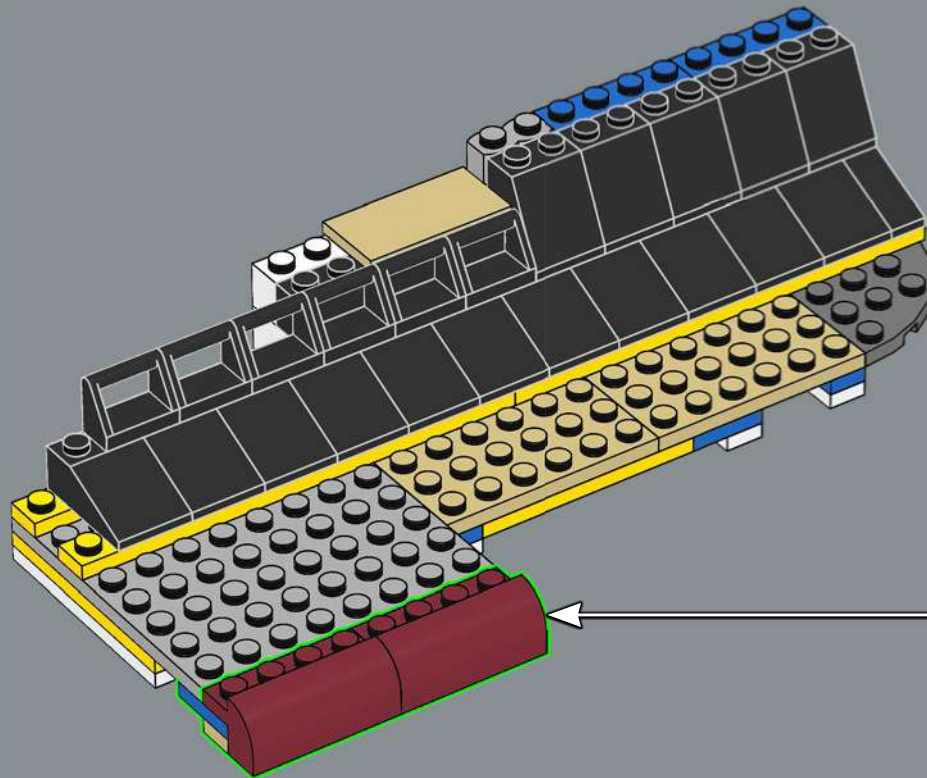
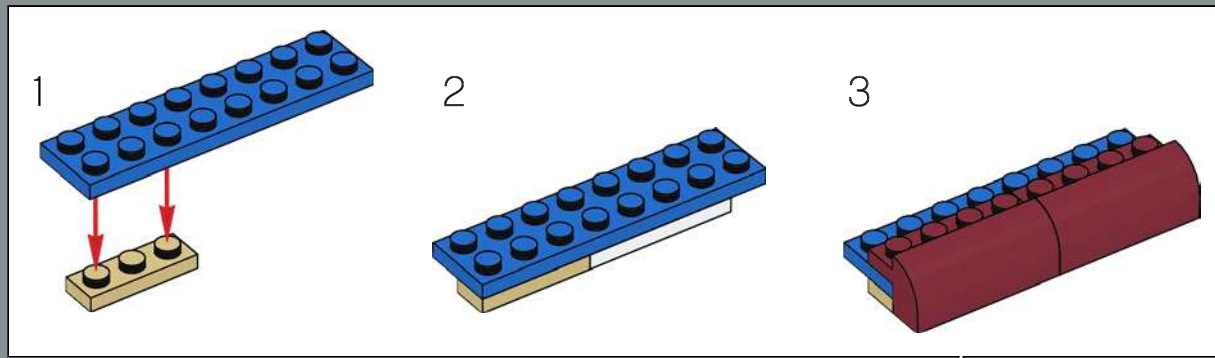

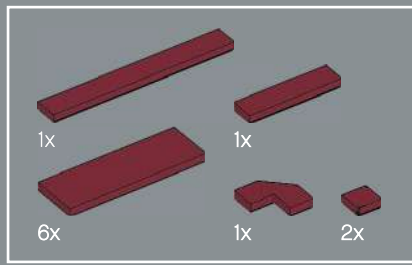

224

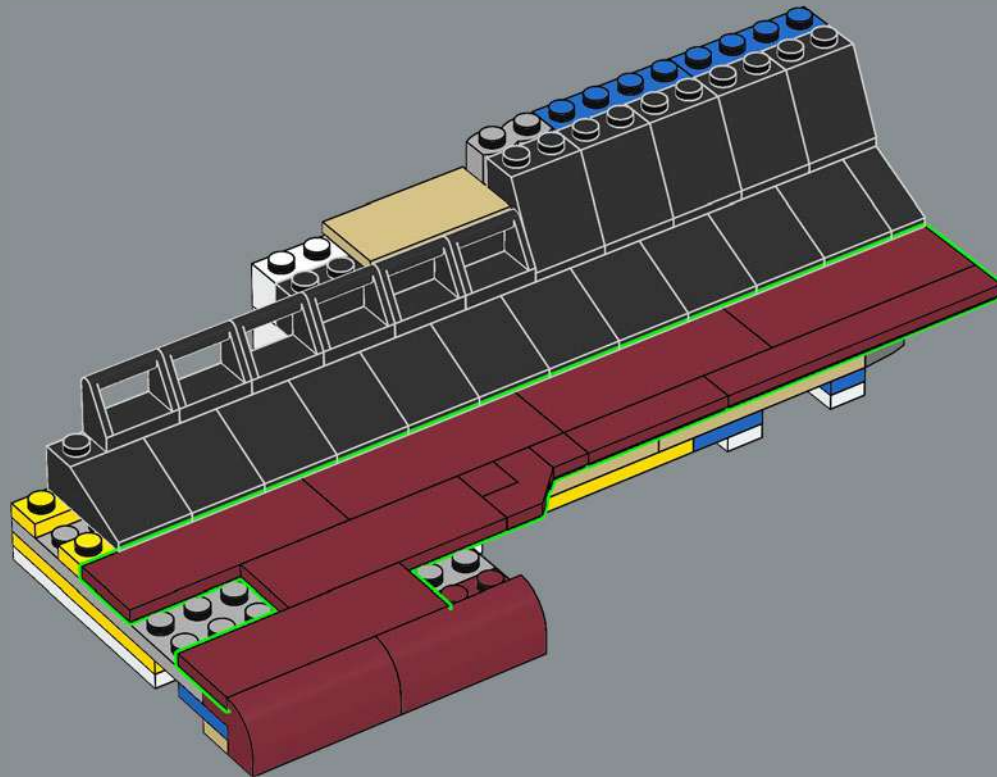

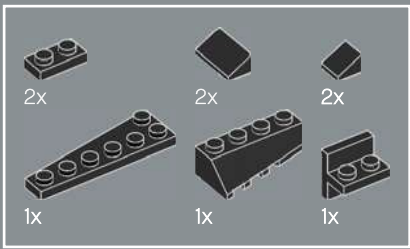

225

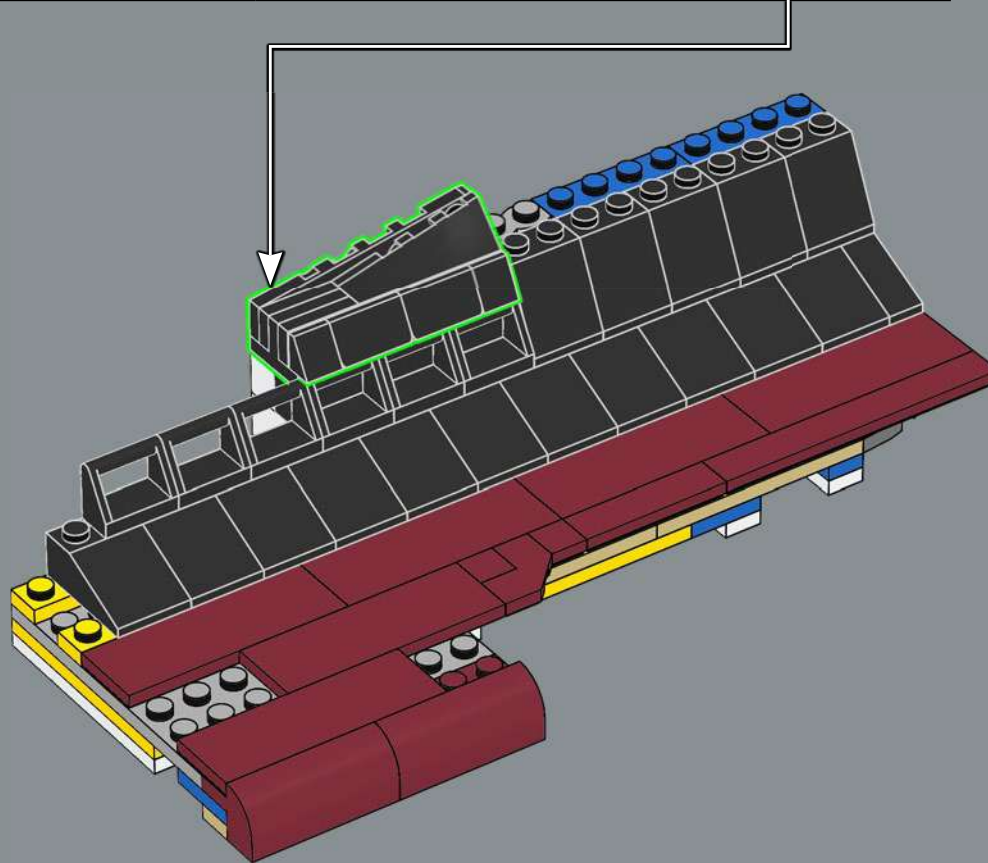
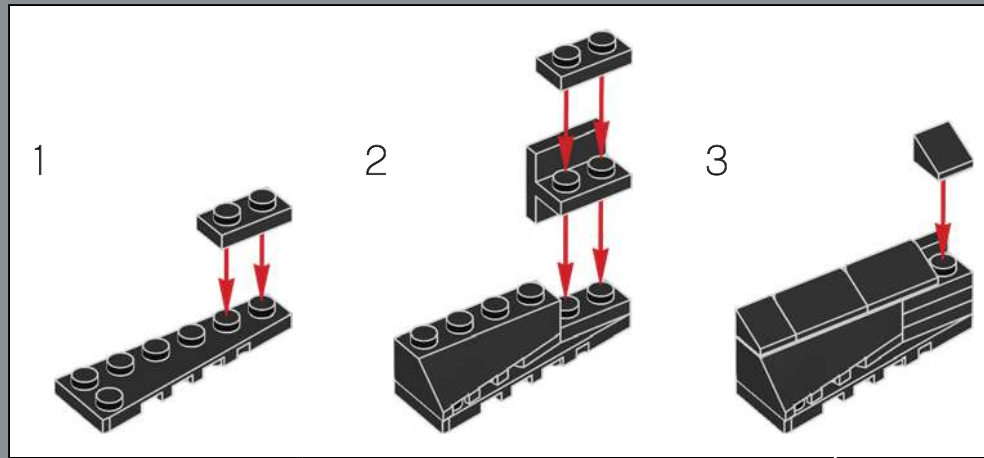

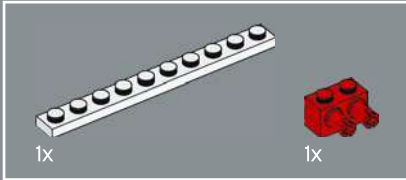
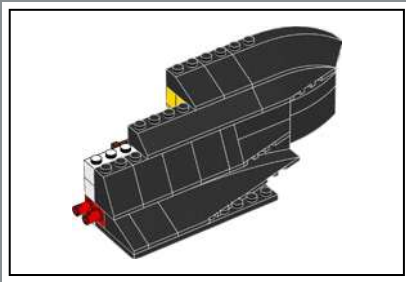

226

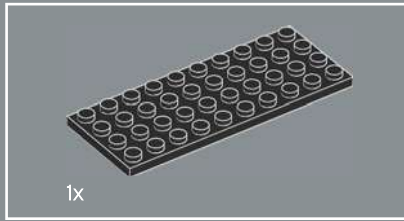
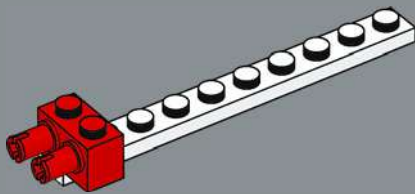

227

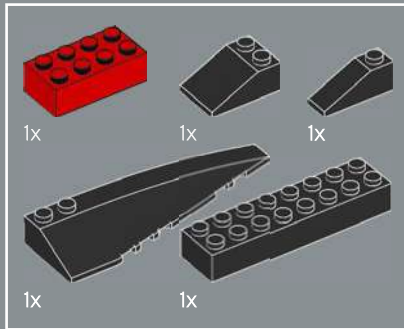
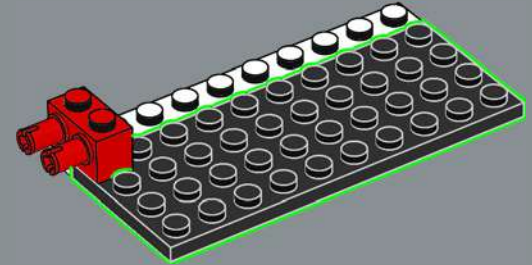

228

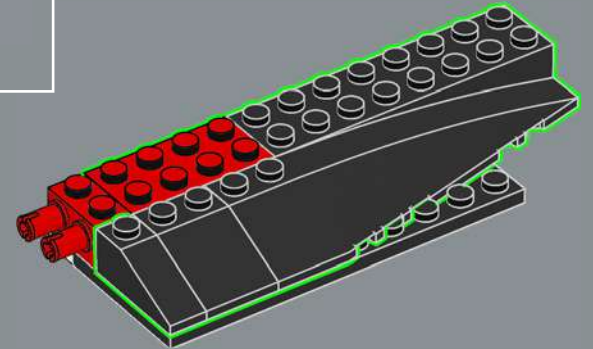

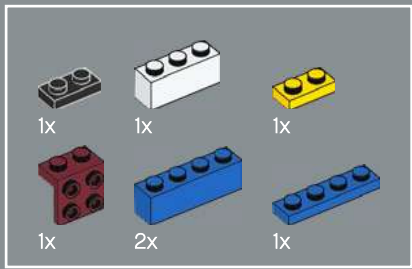

229

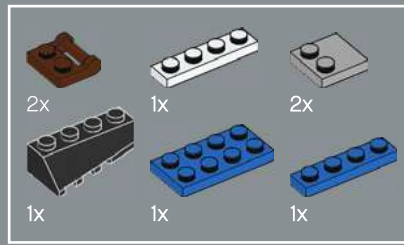
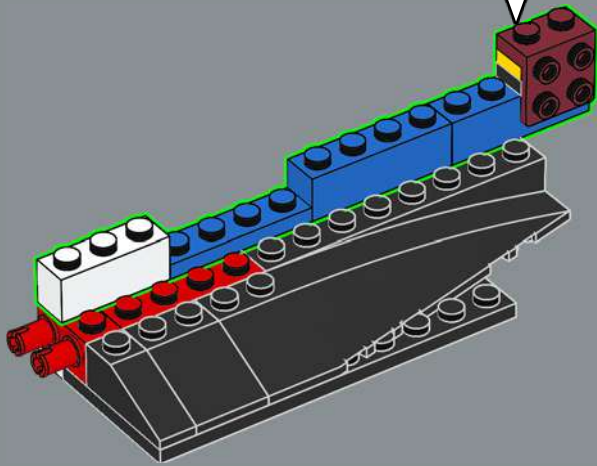
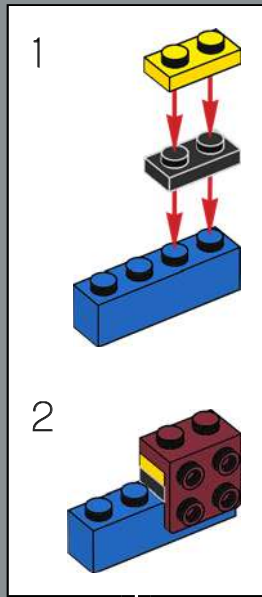

230

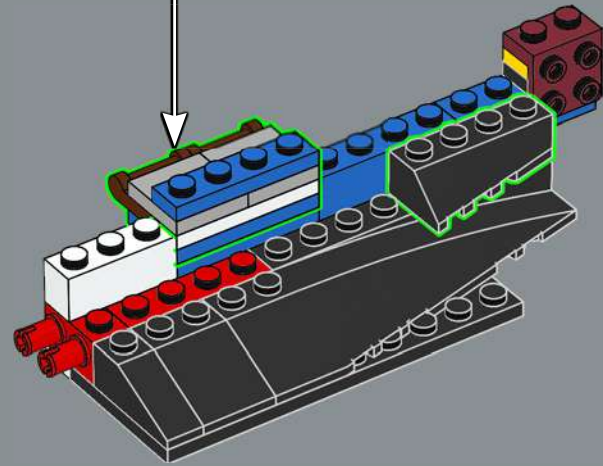
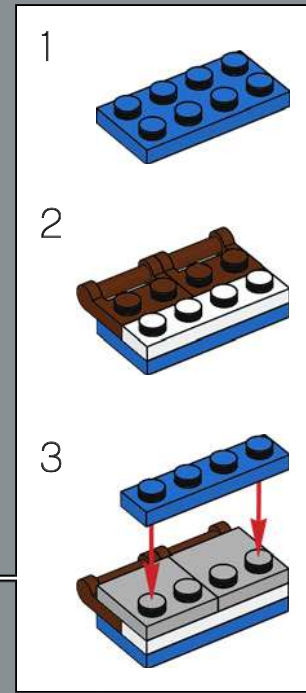

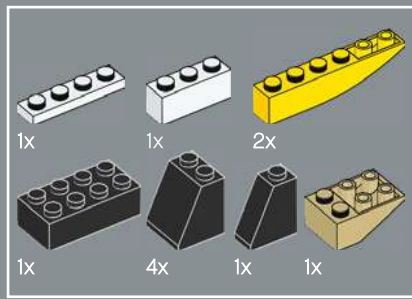

231

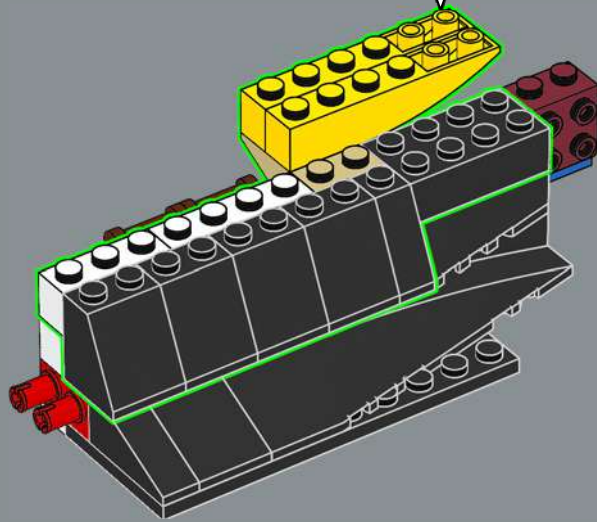
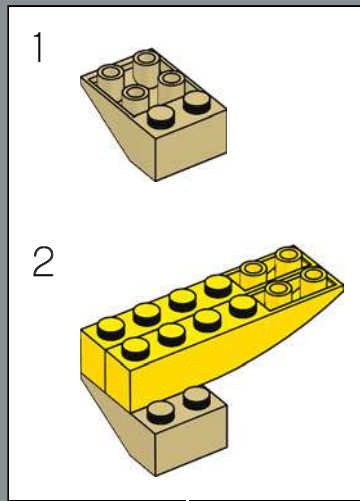

232

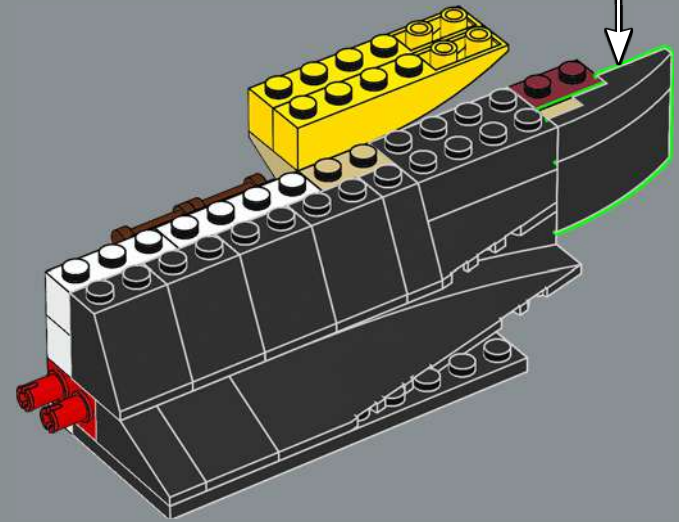
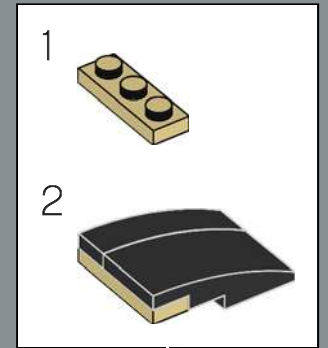

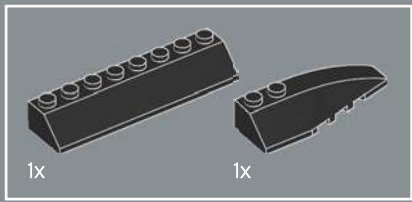

233

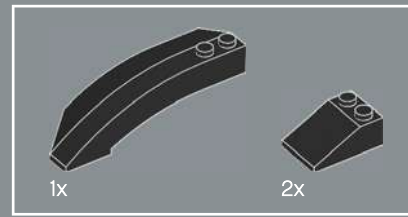
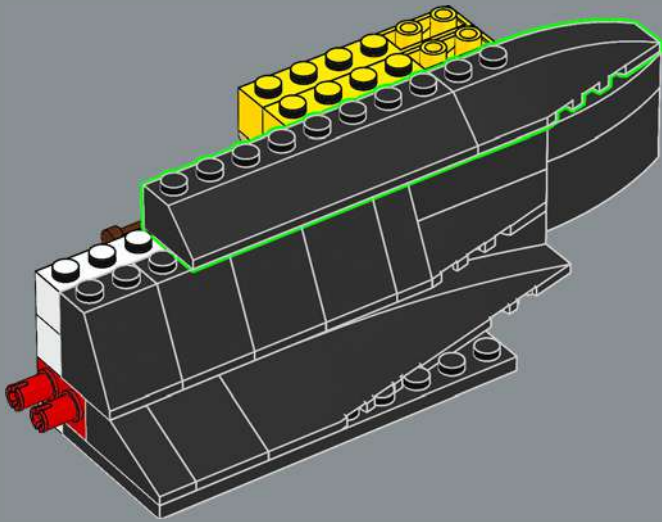

234

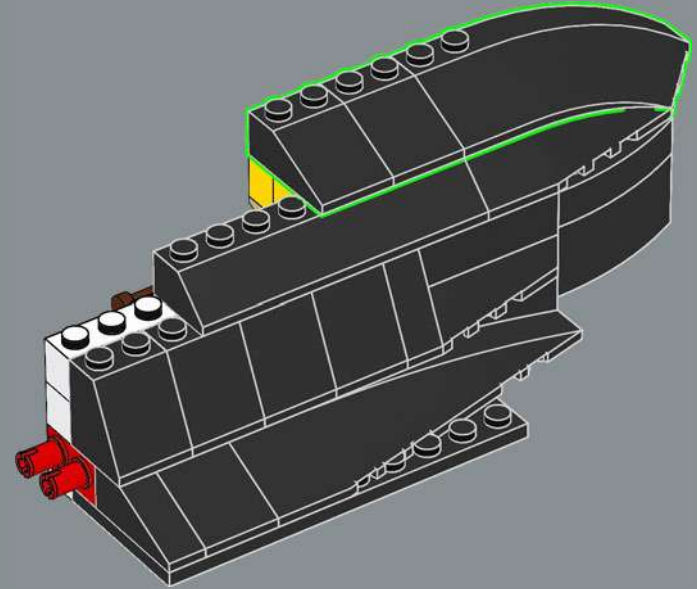

235

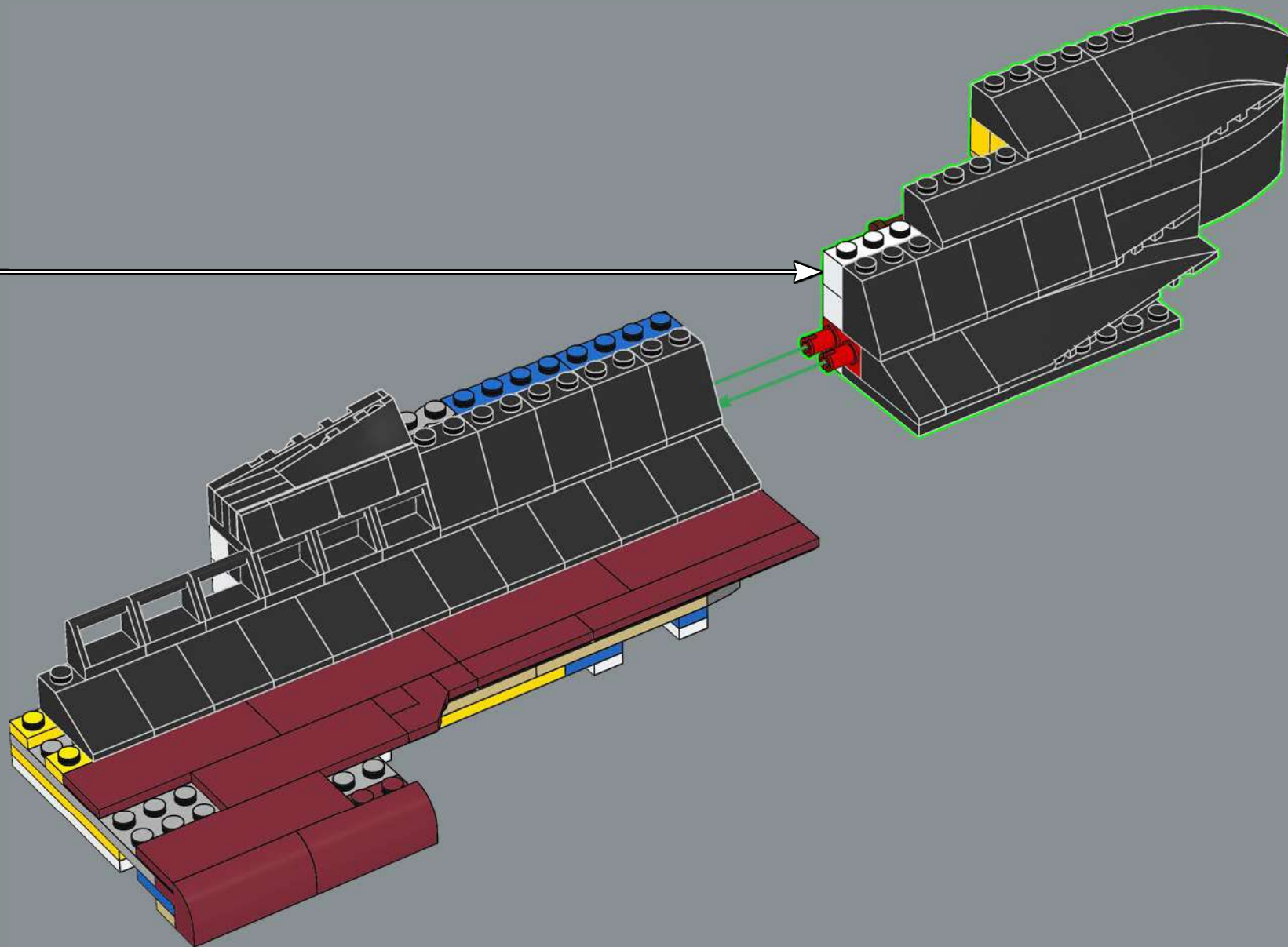

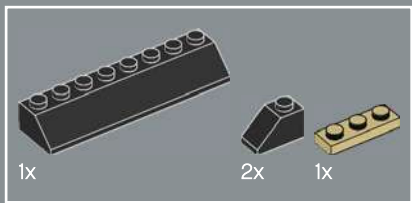

236

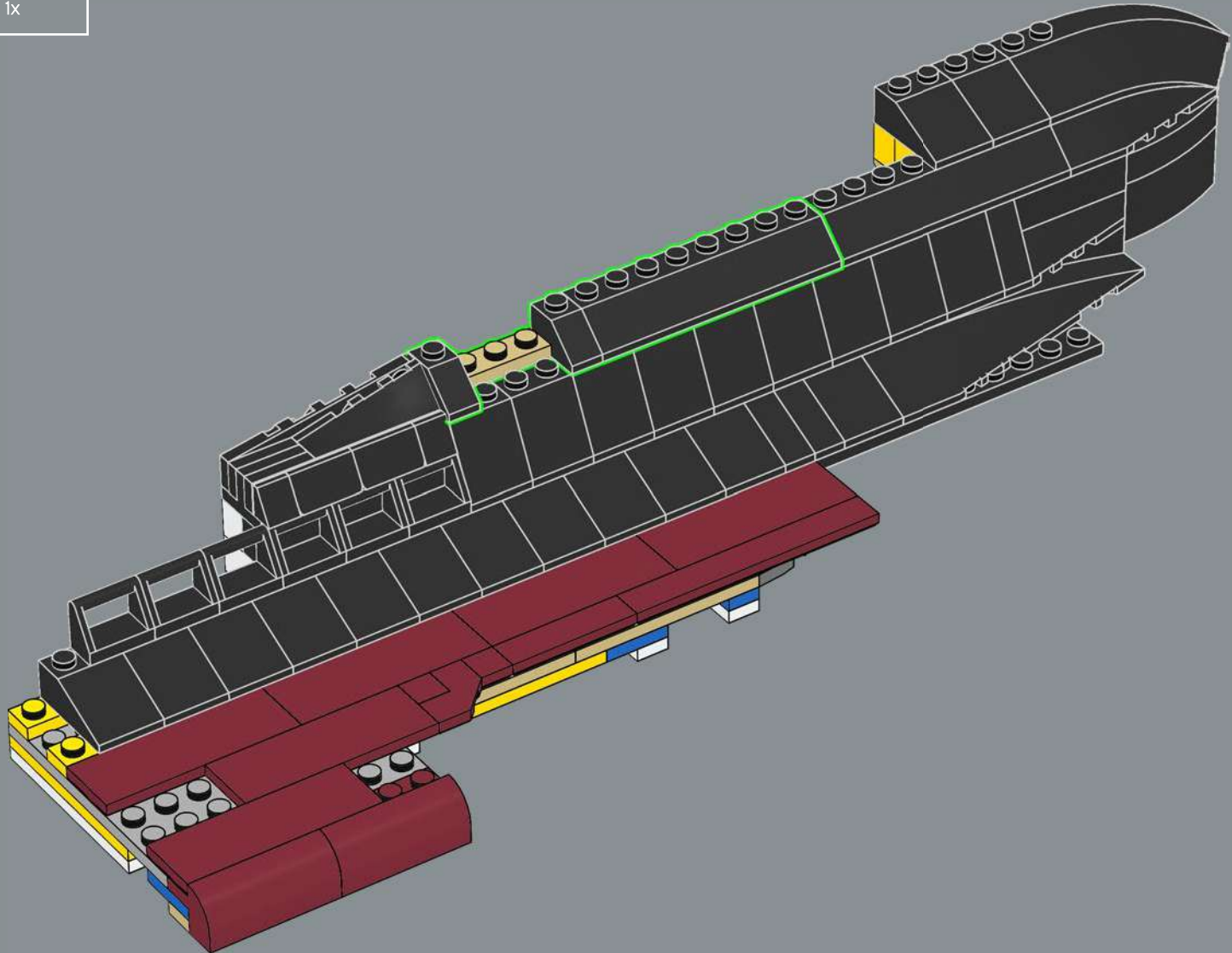

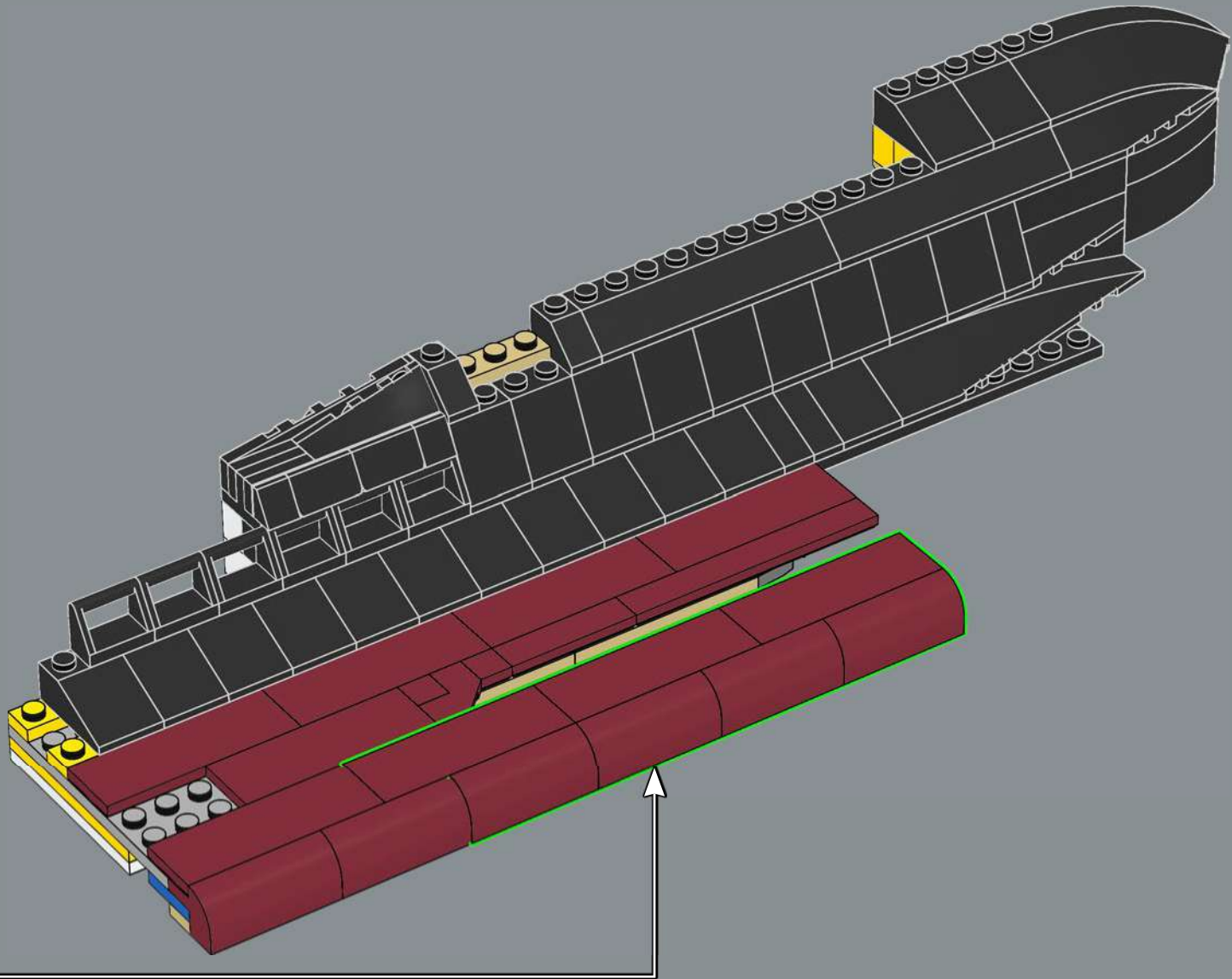

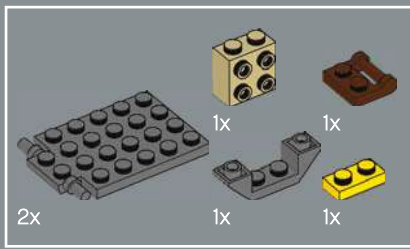

238

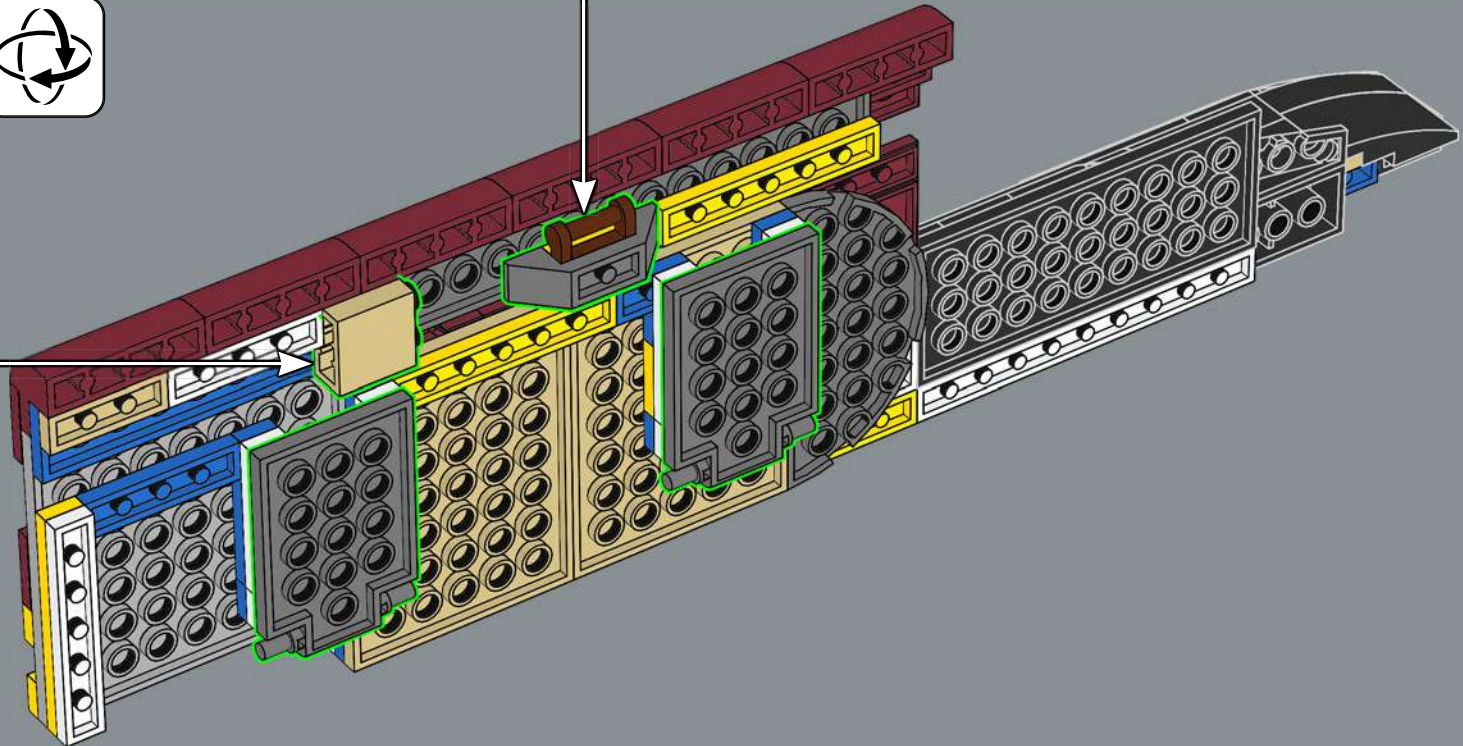
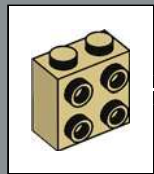
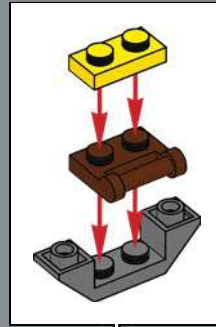

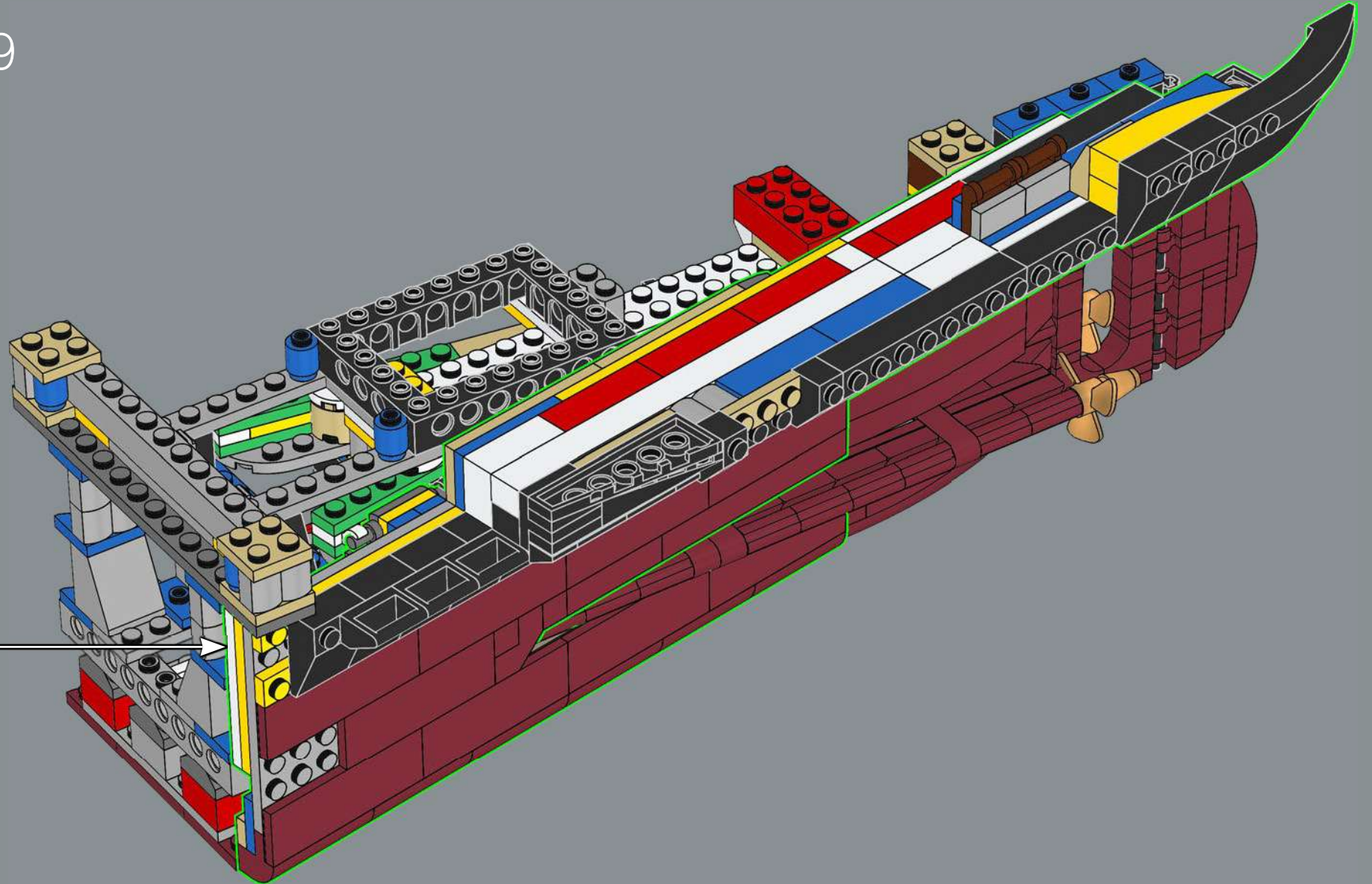

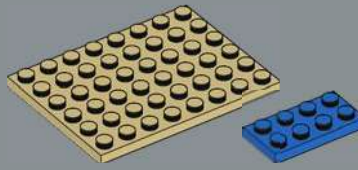
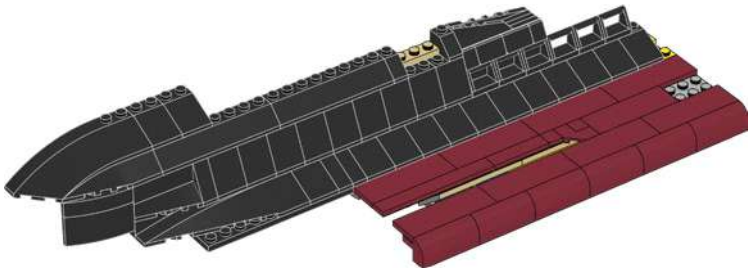
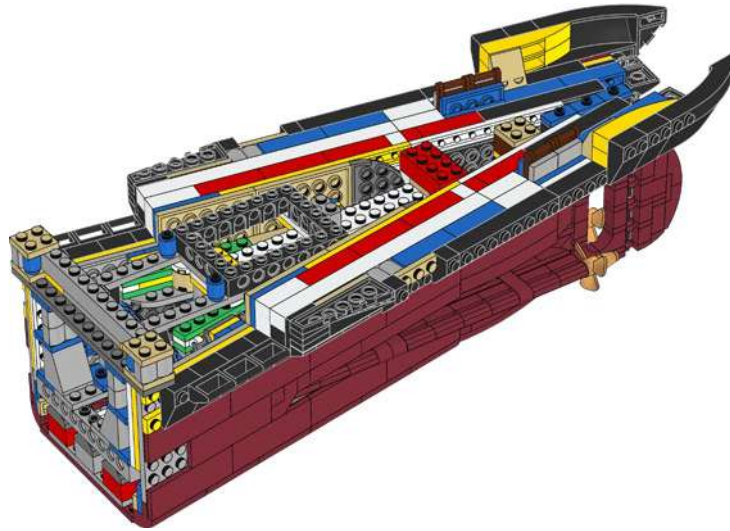
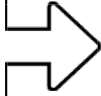

240

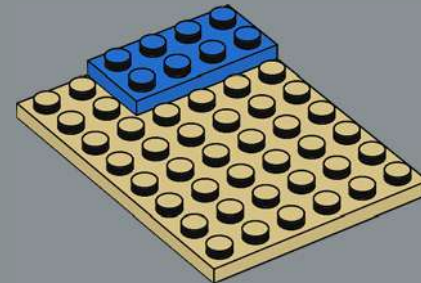

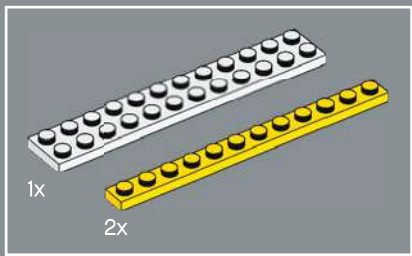

241

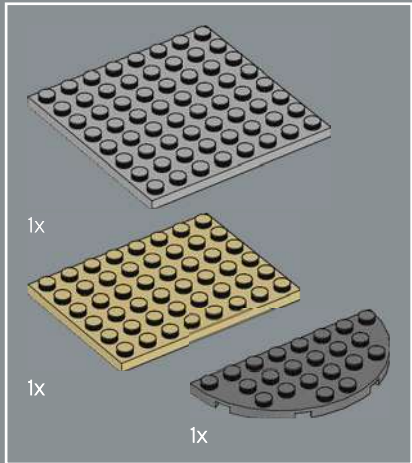
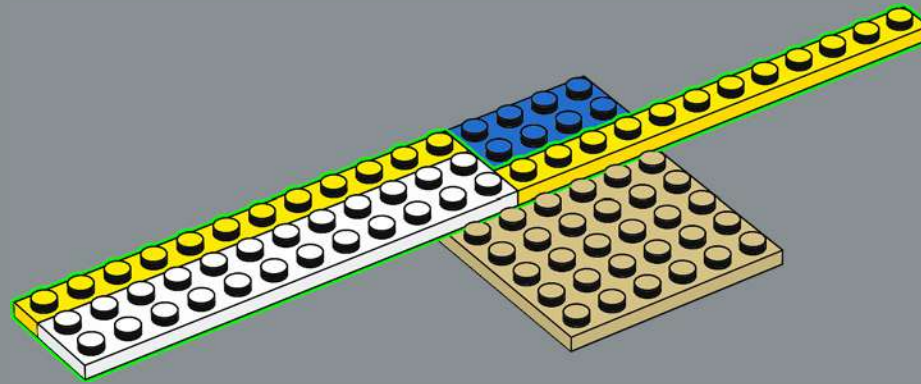

242

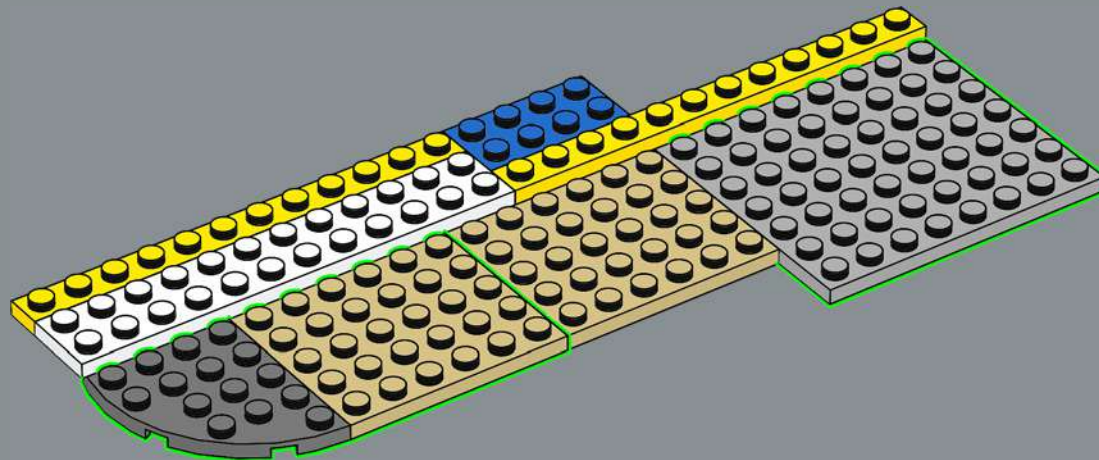

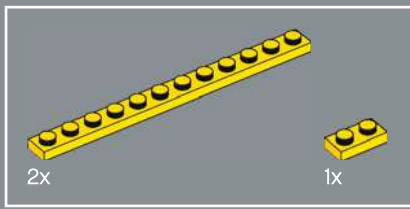

243

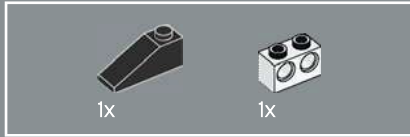
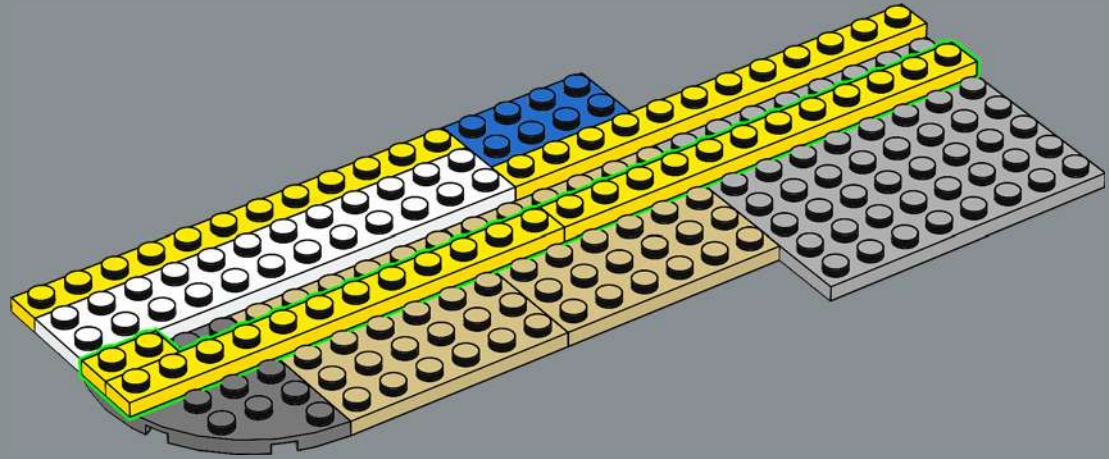

244

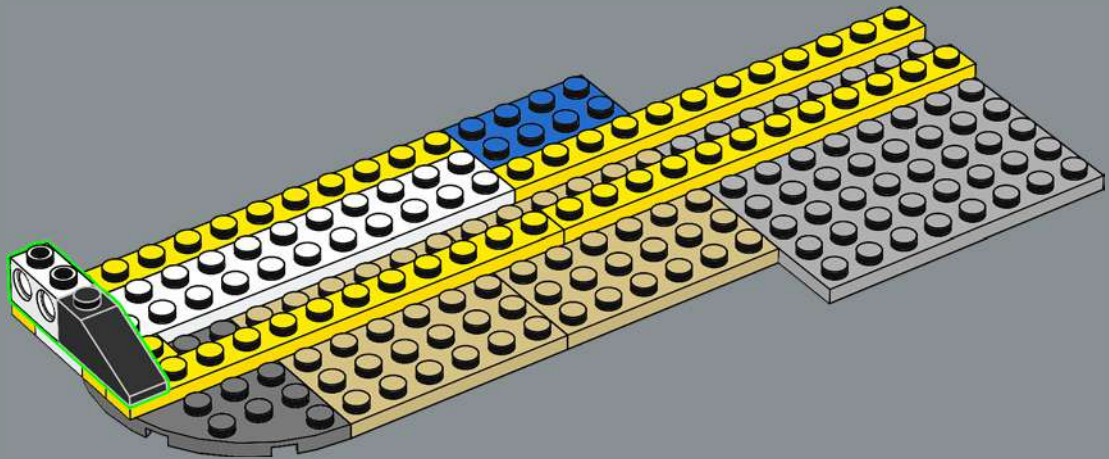

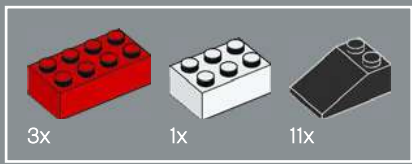

245

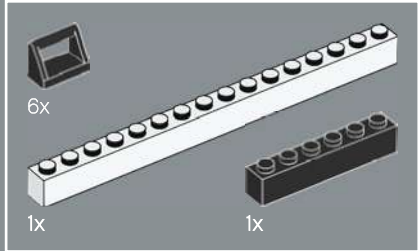
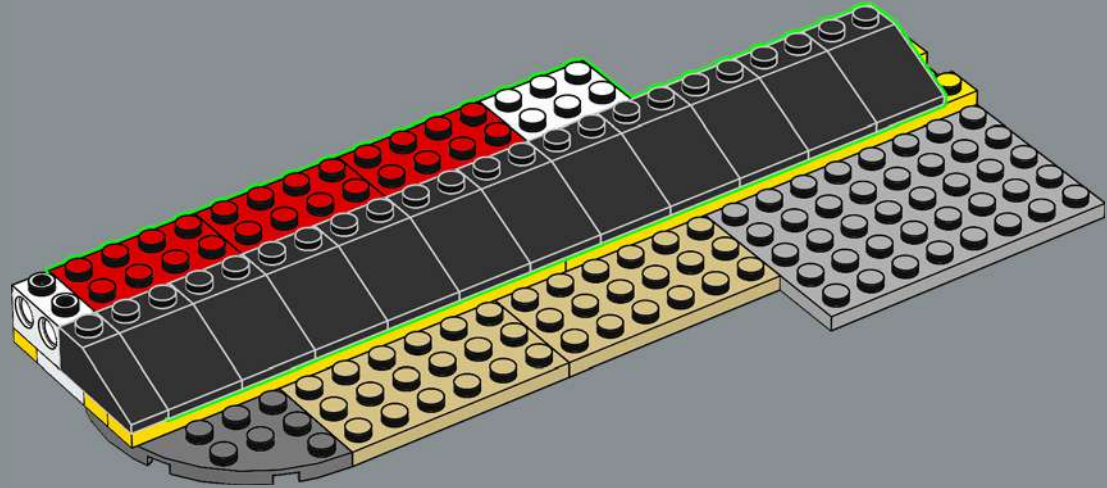

246

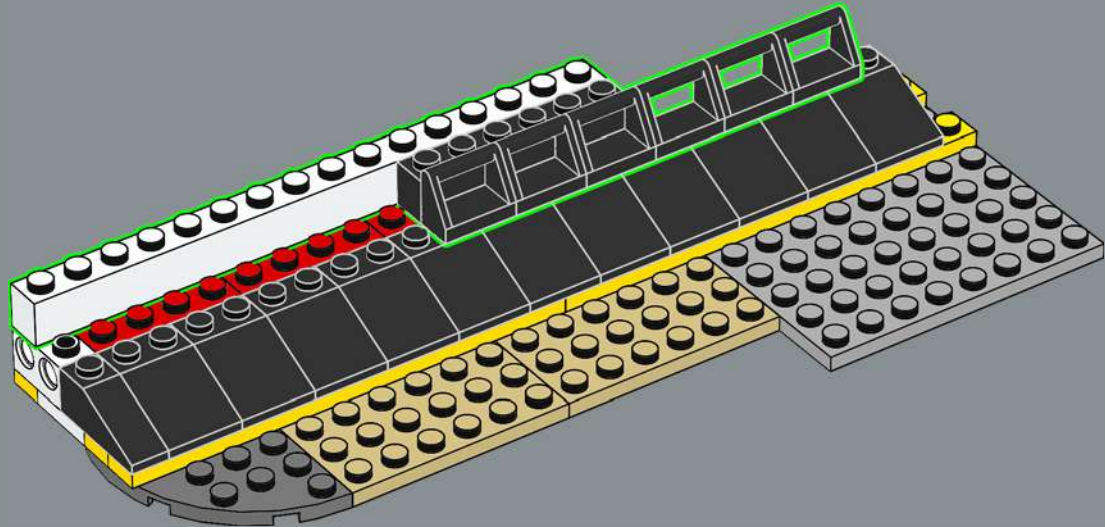

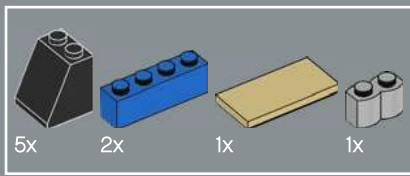

247

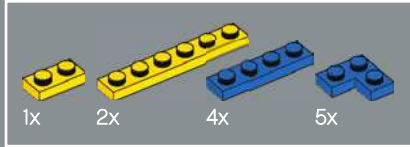
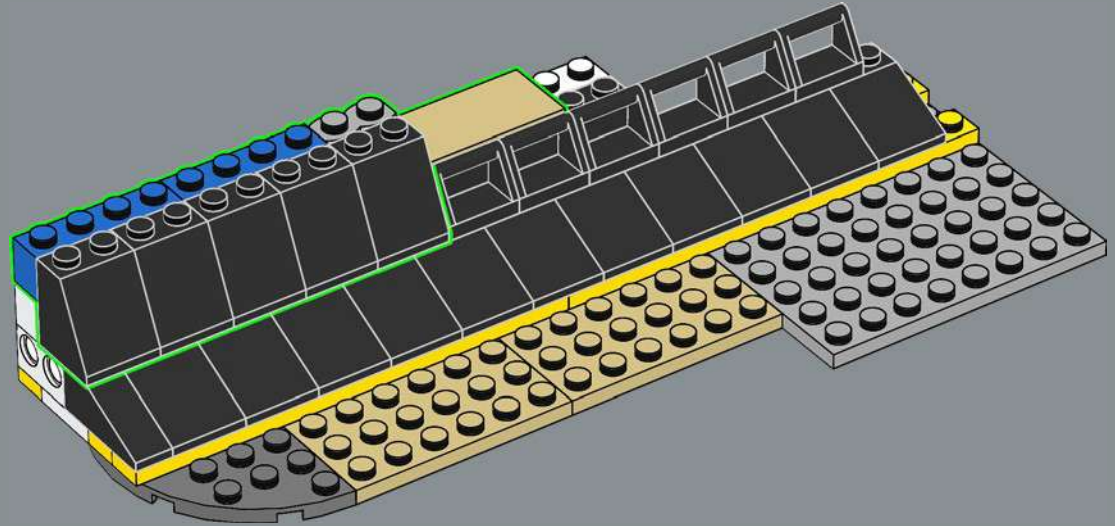

248

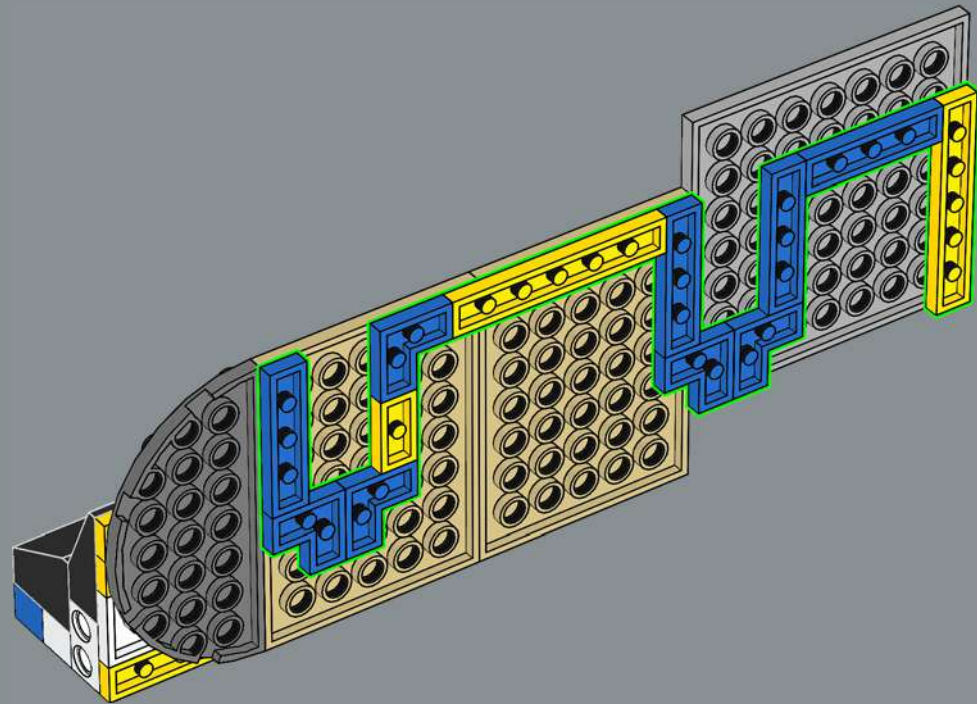

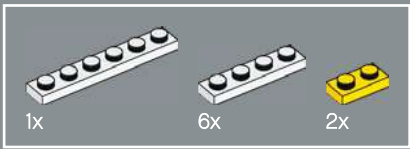

249

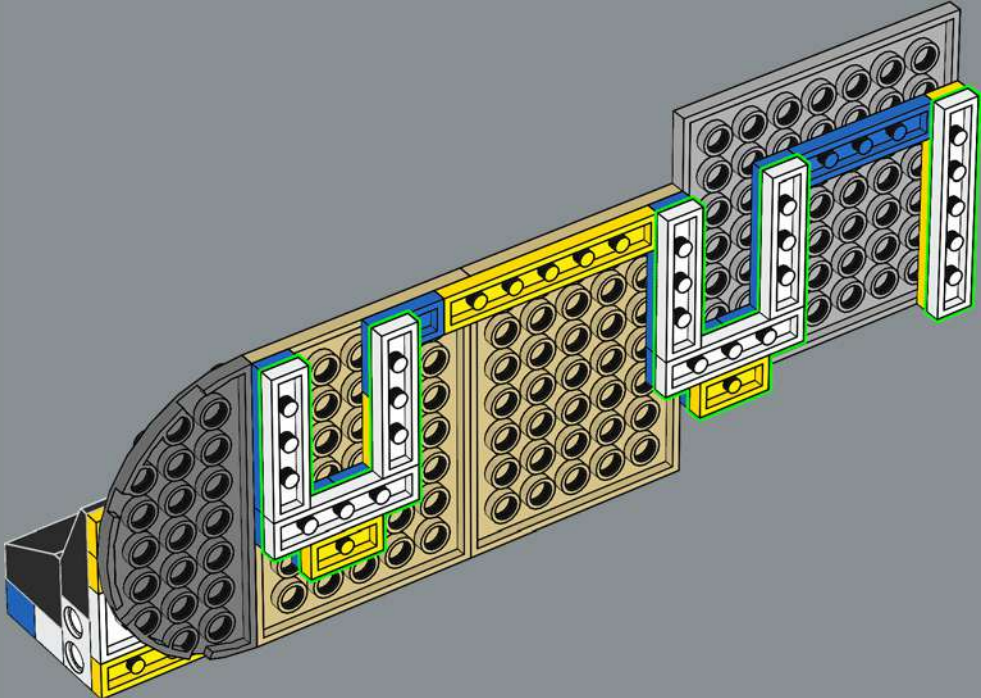

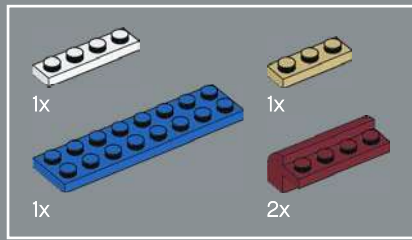

250

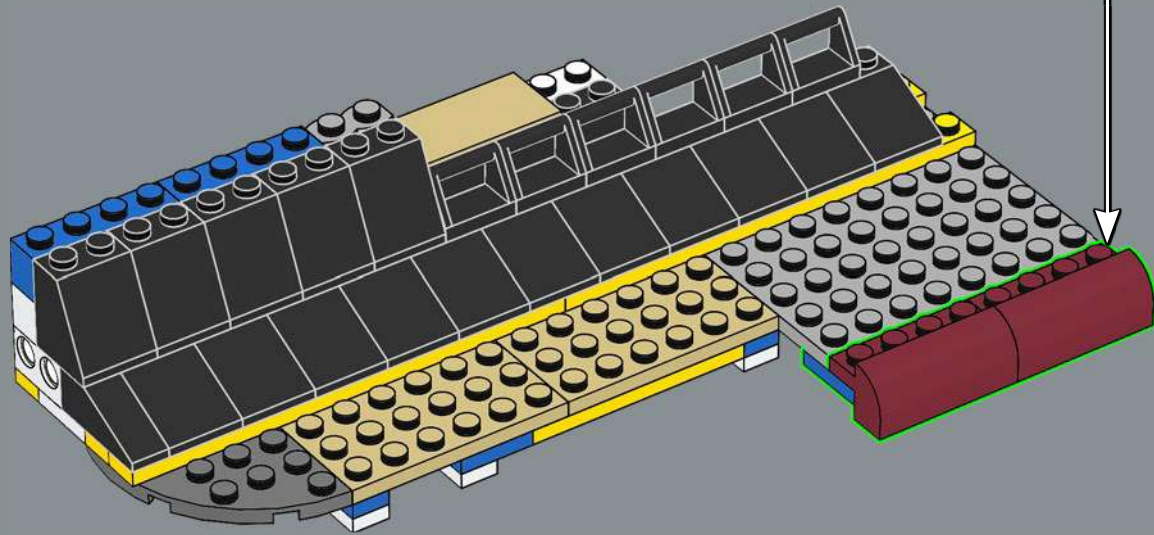
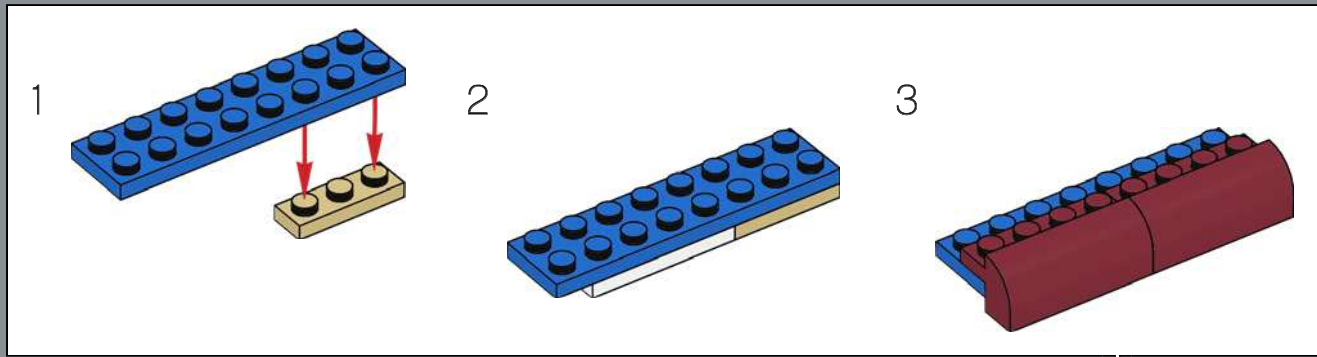

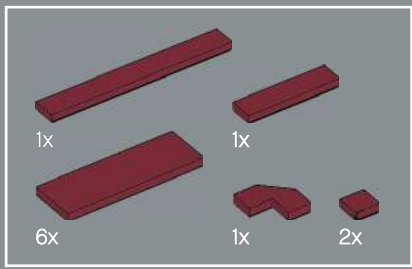

251

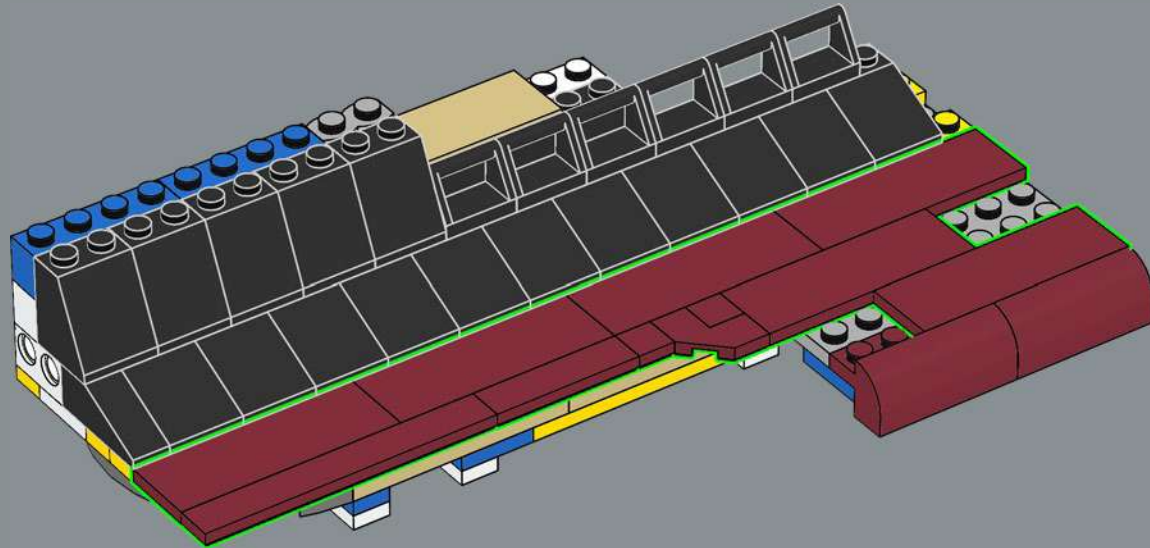

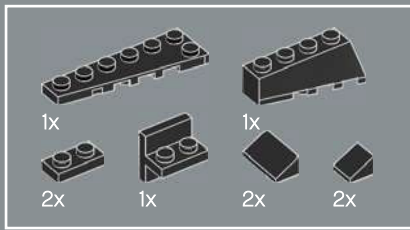

252

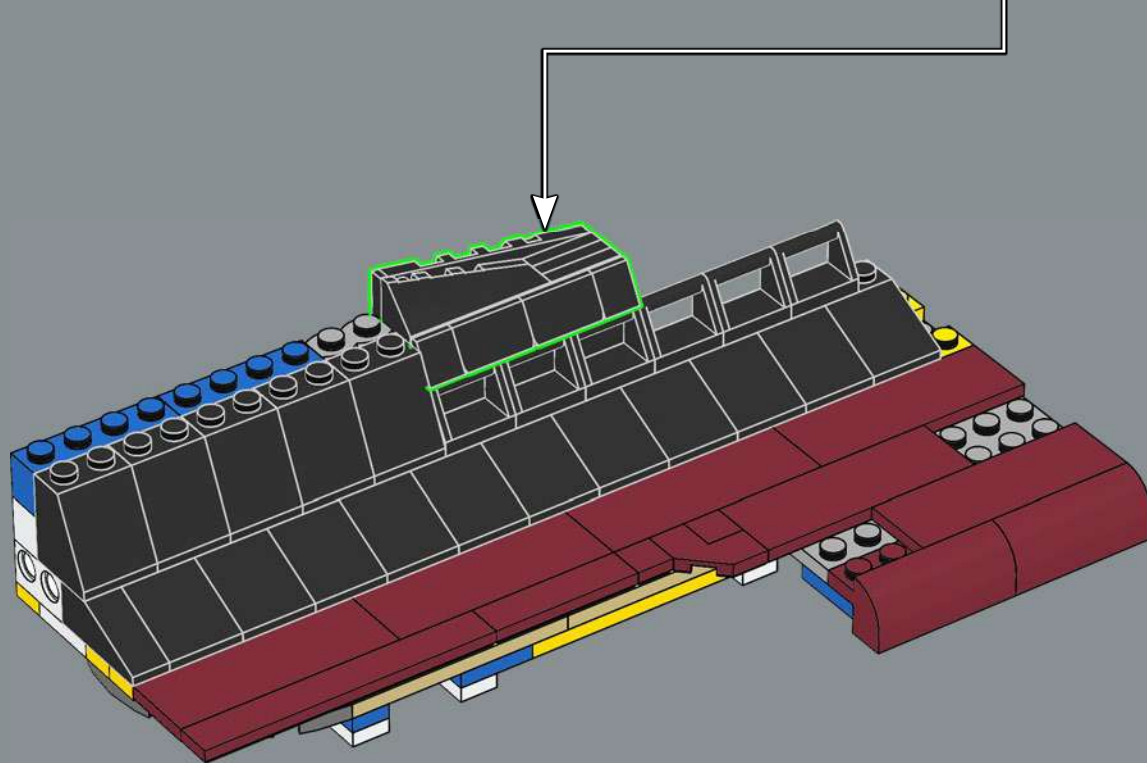
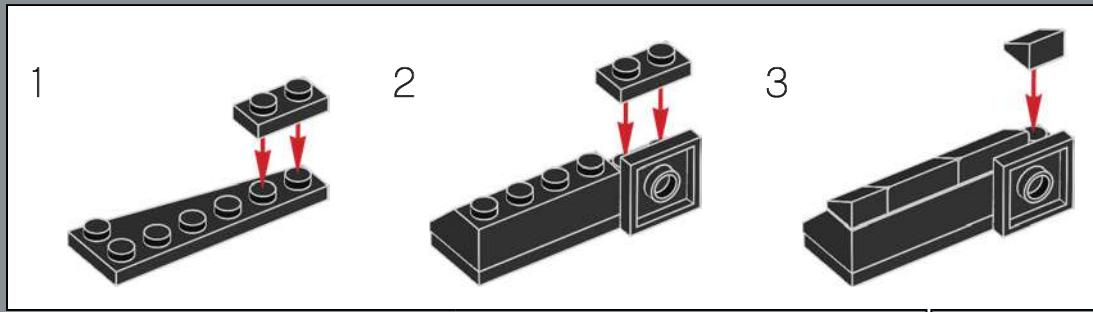

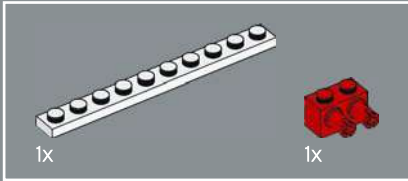
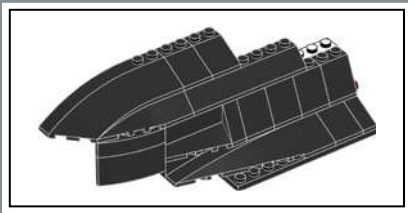

253

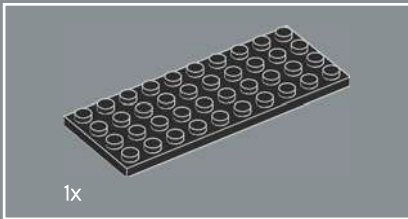
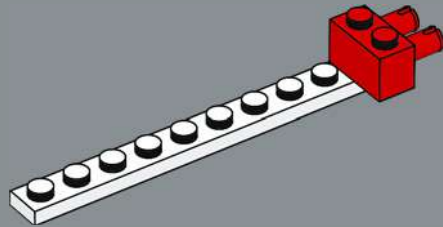

254

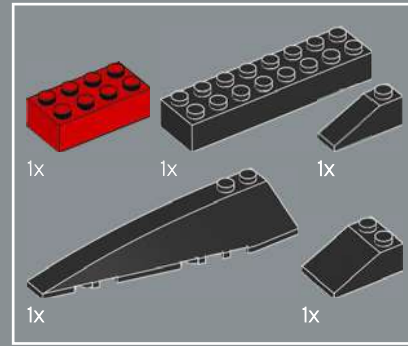
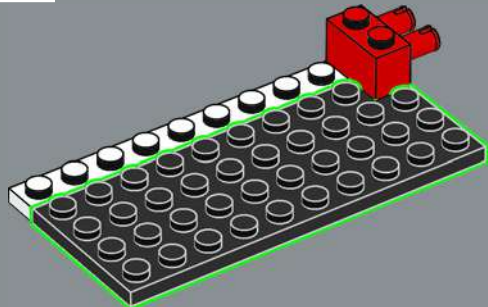

255

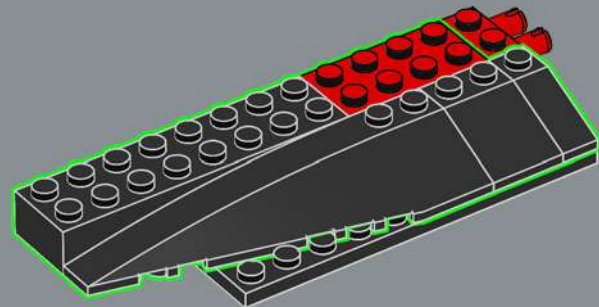

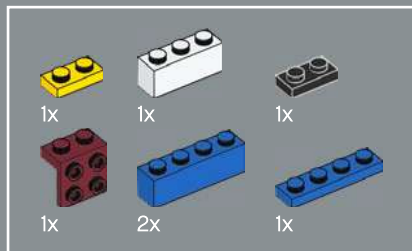

256

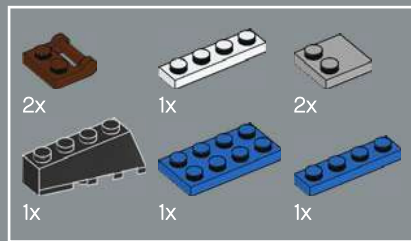
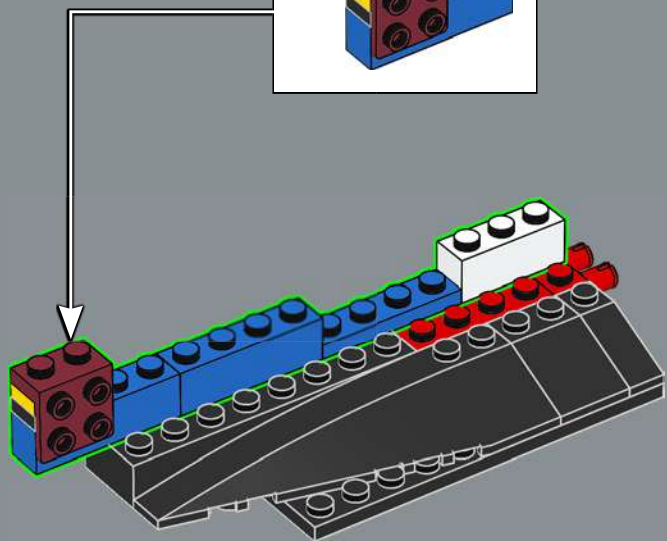
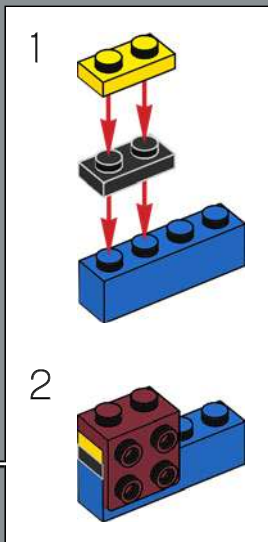

257

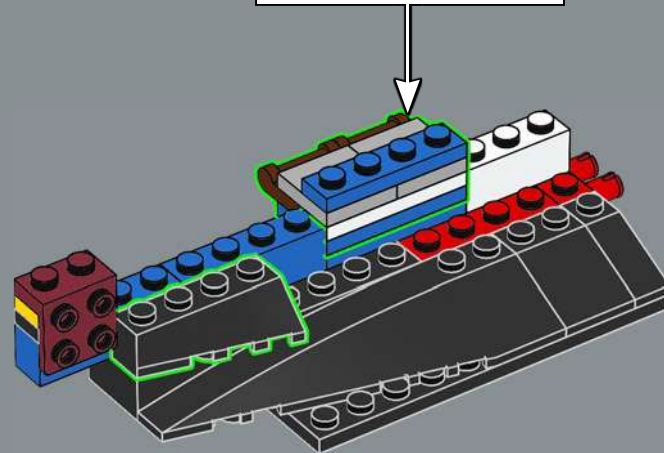
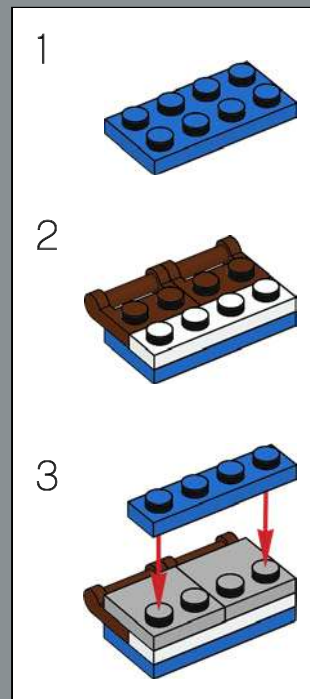

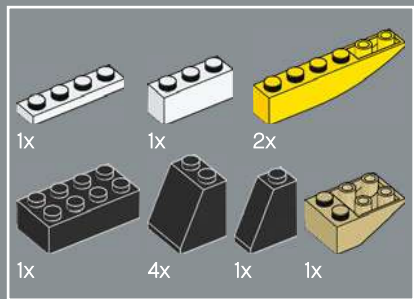

258

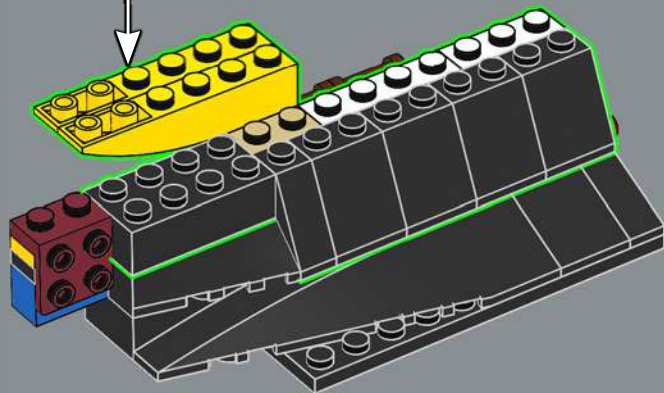
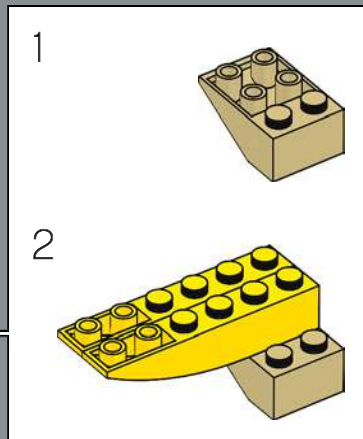

259

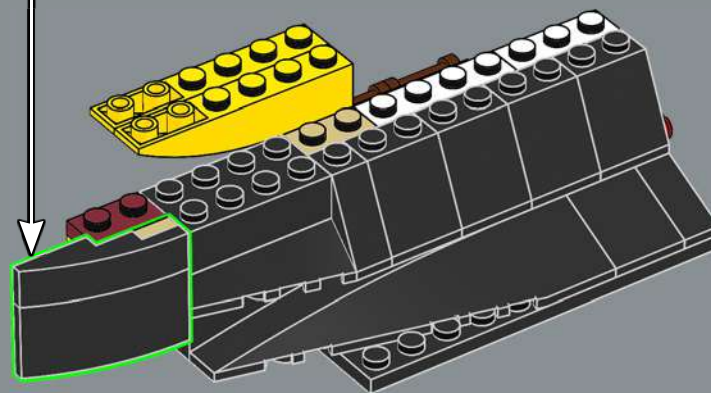
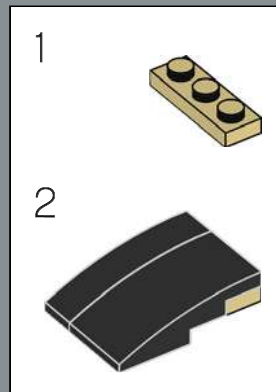

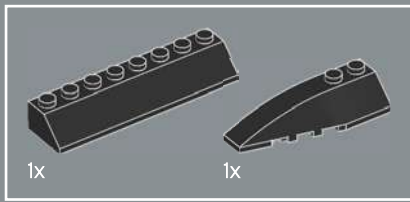

260

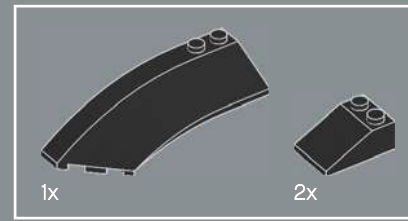
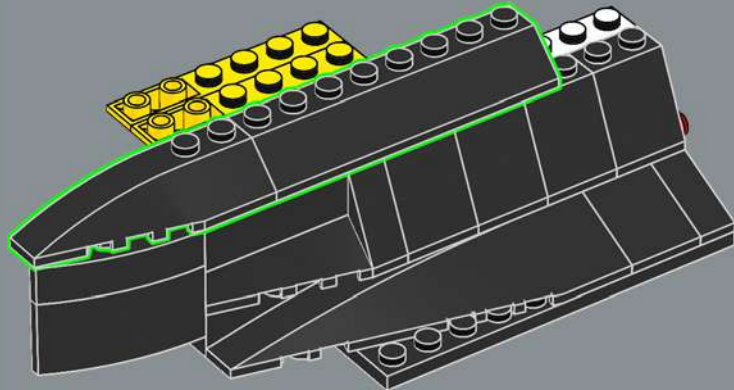

261

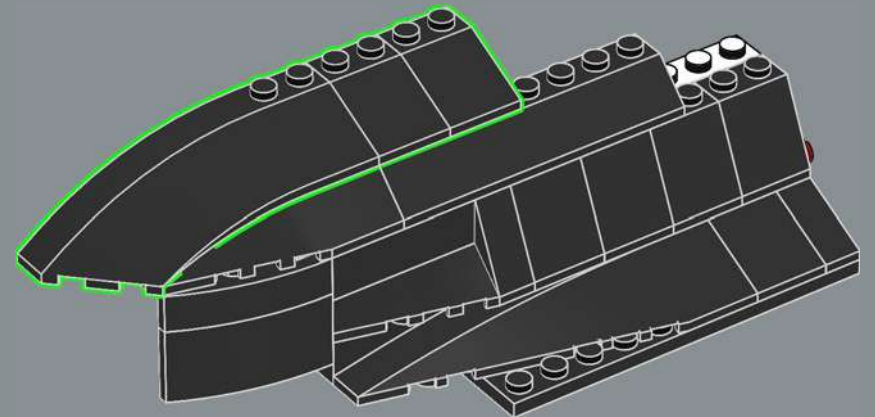

262

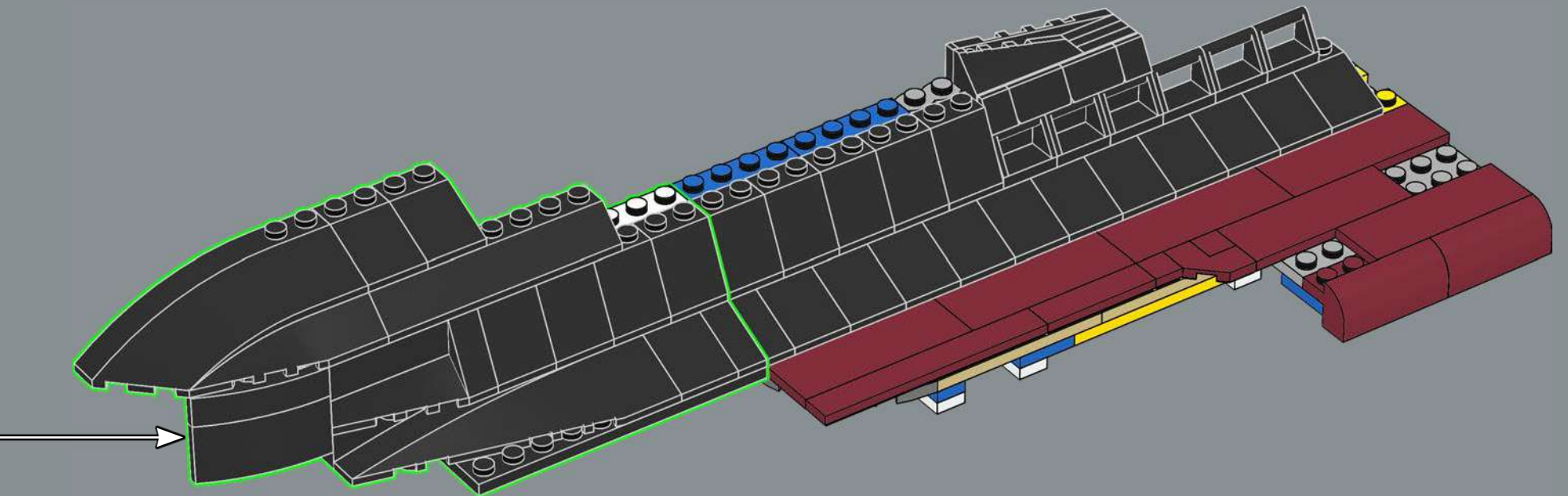

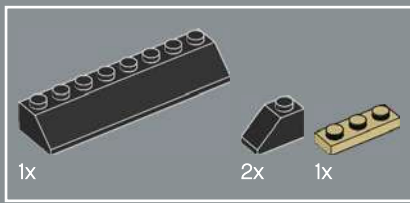

263

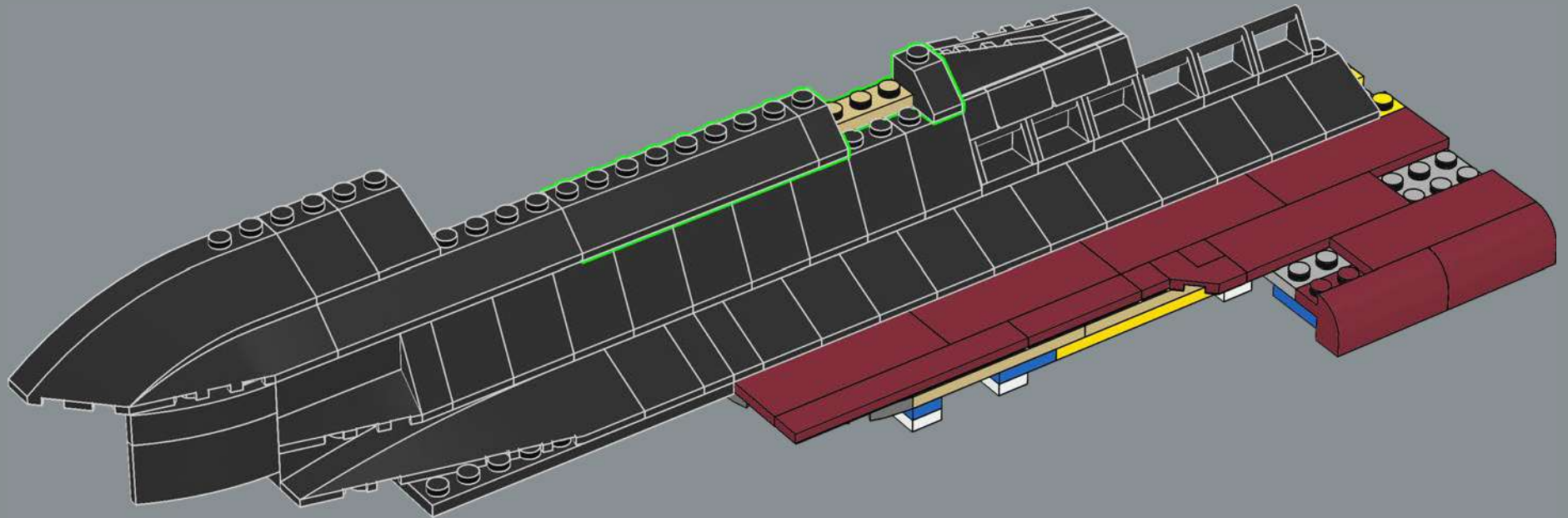

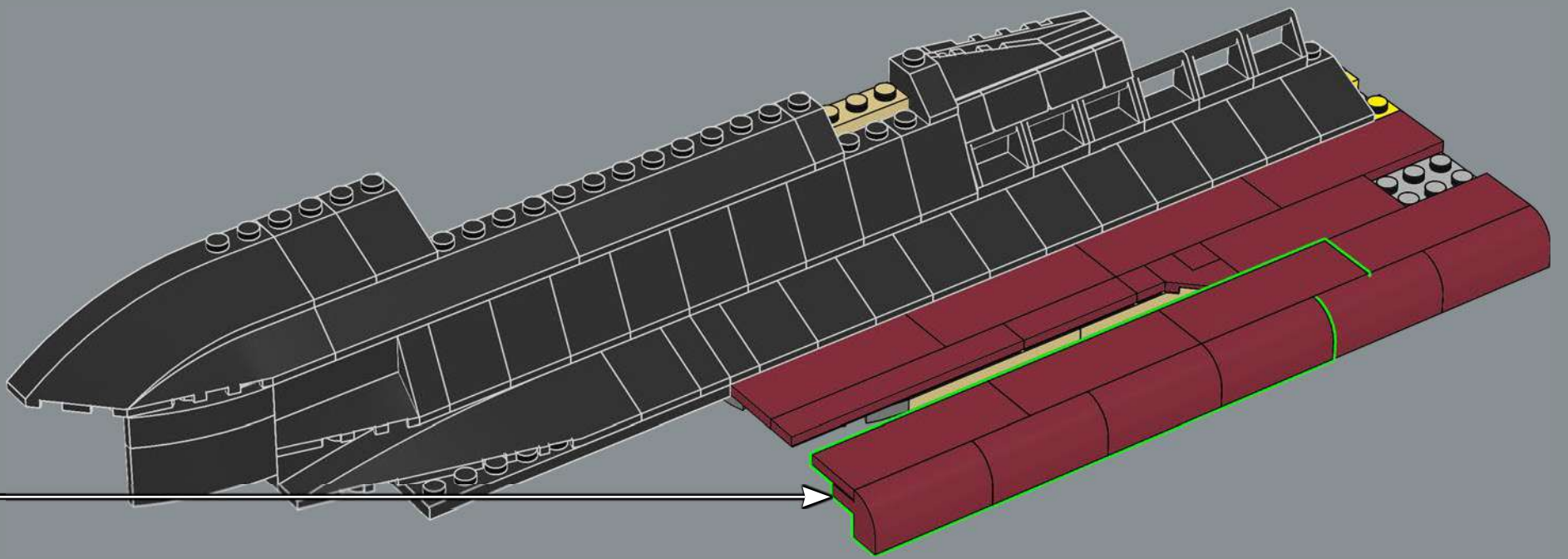

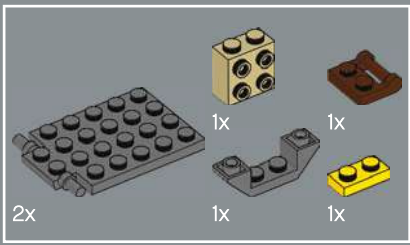

265

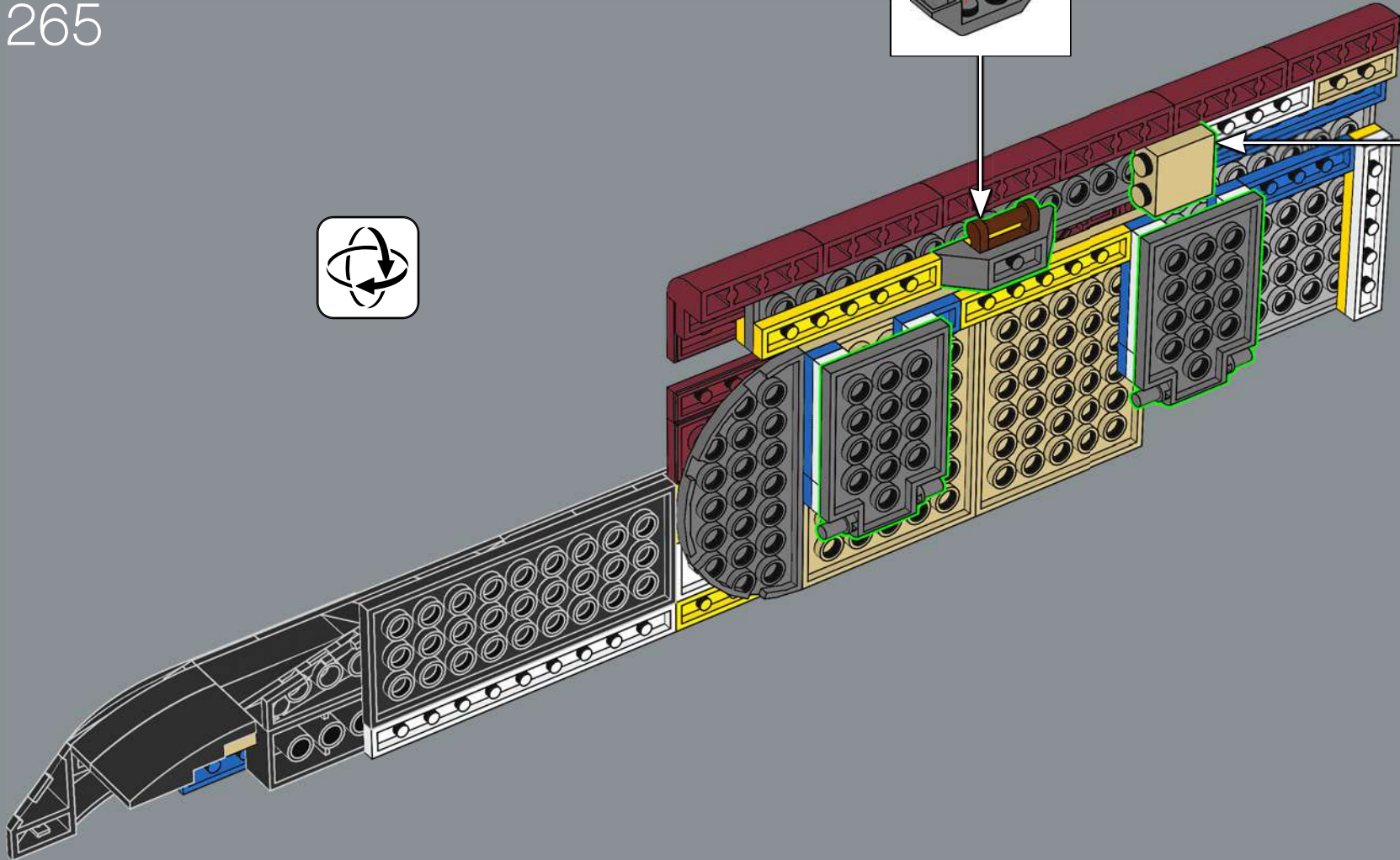
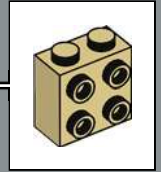
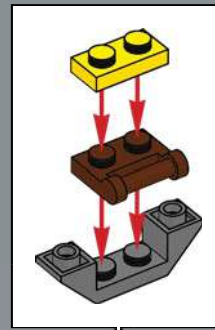

266

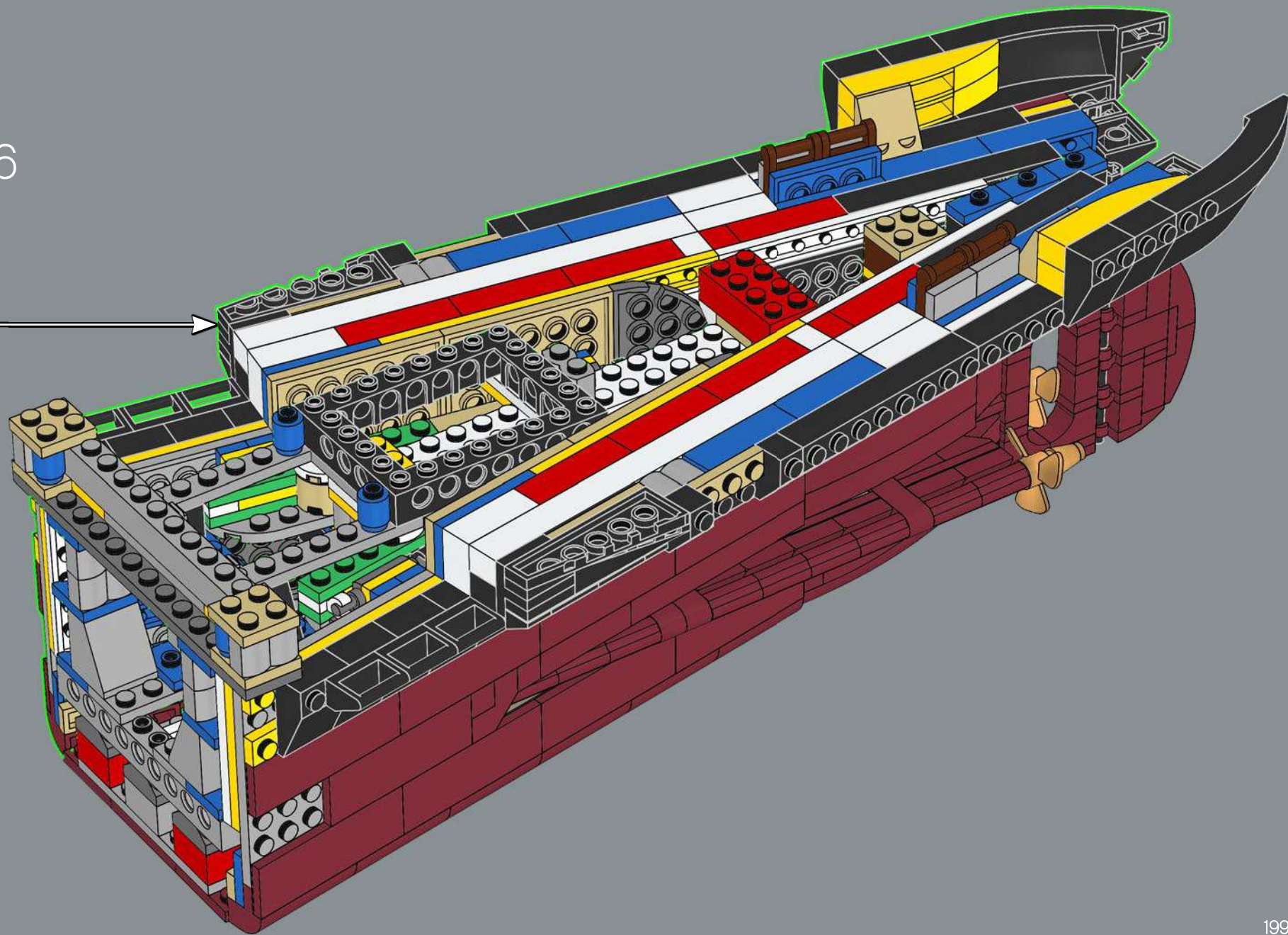

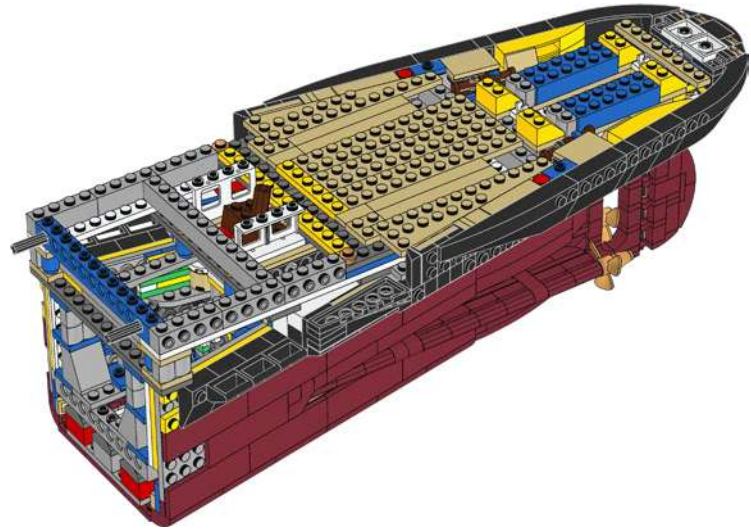
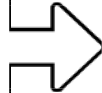

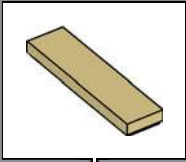
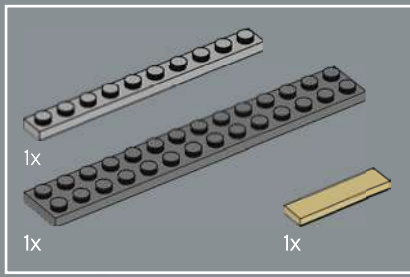

267

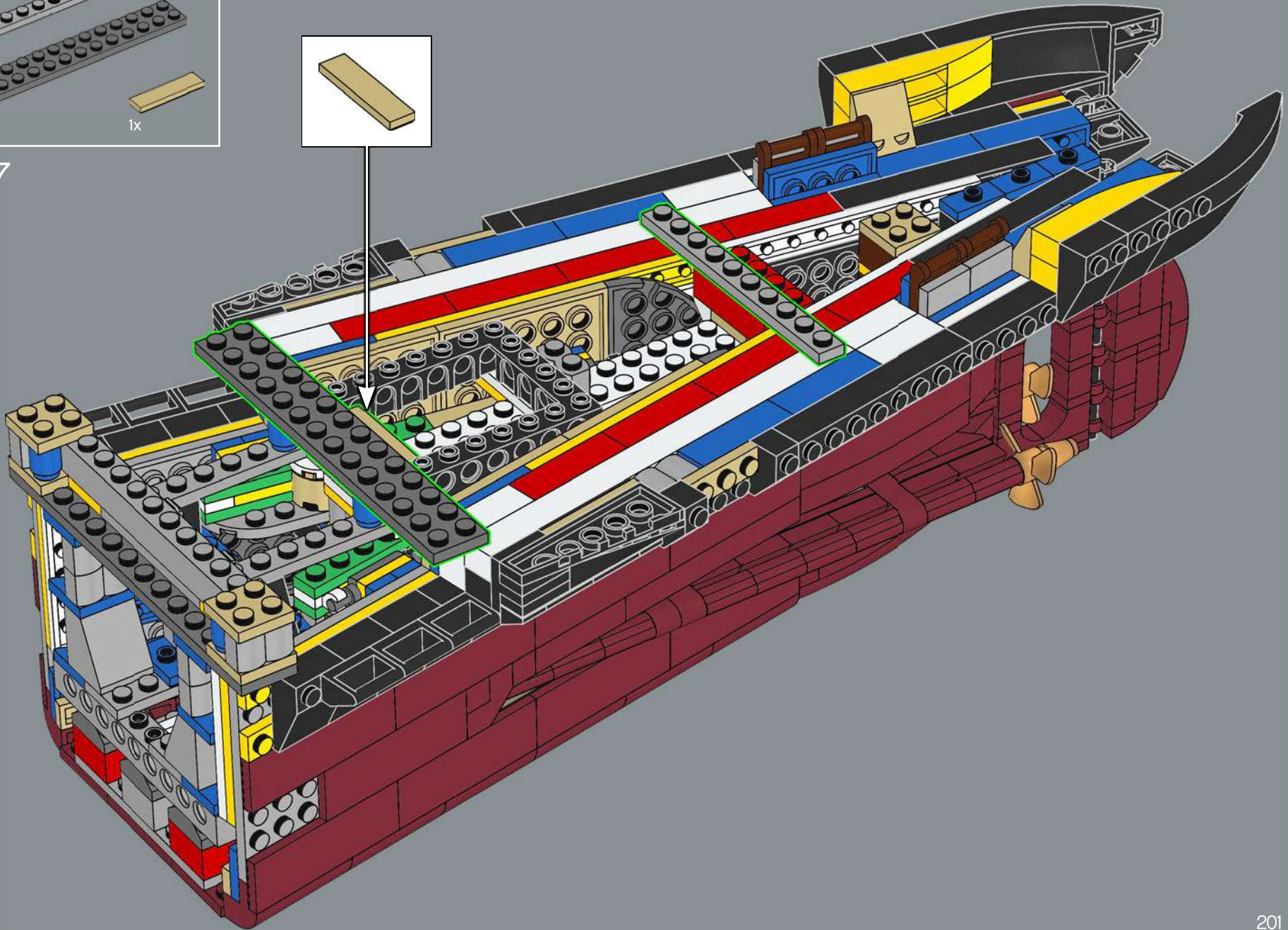

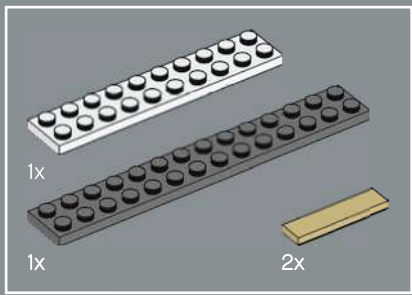

268

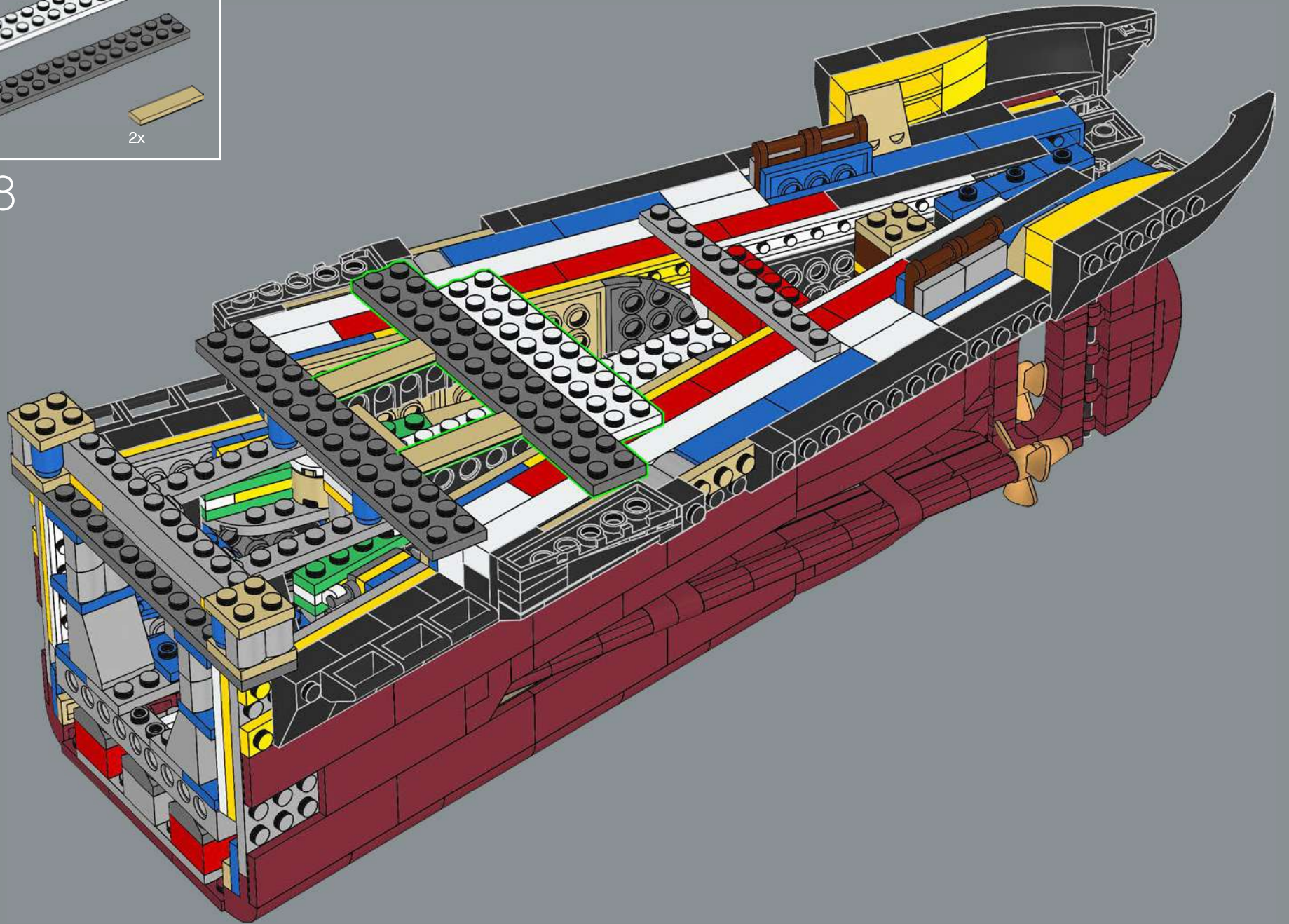

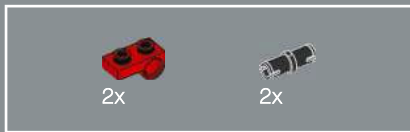

269

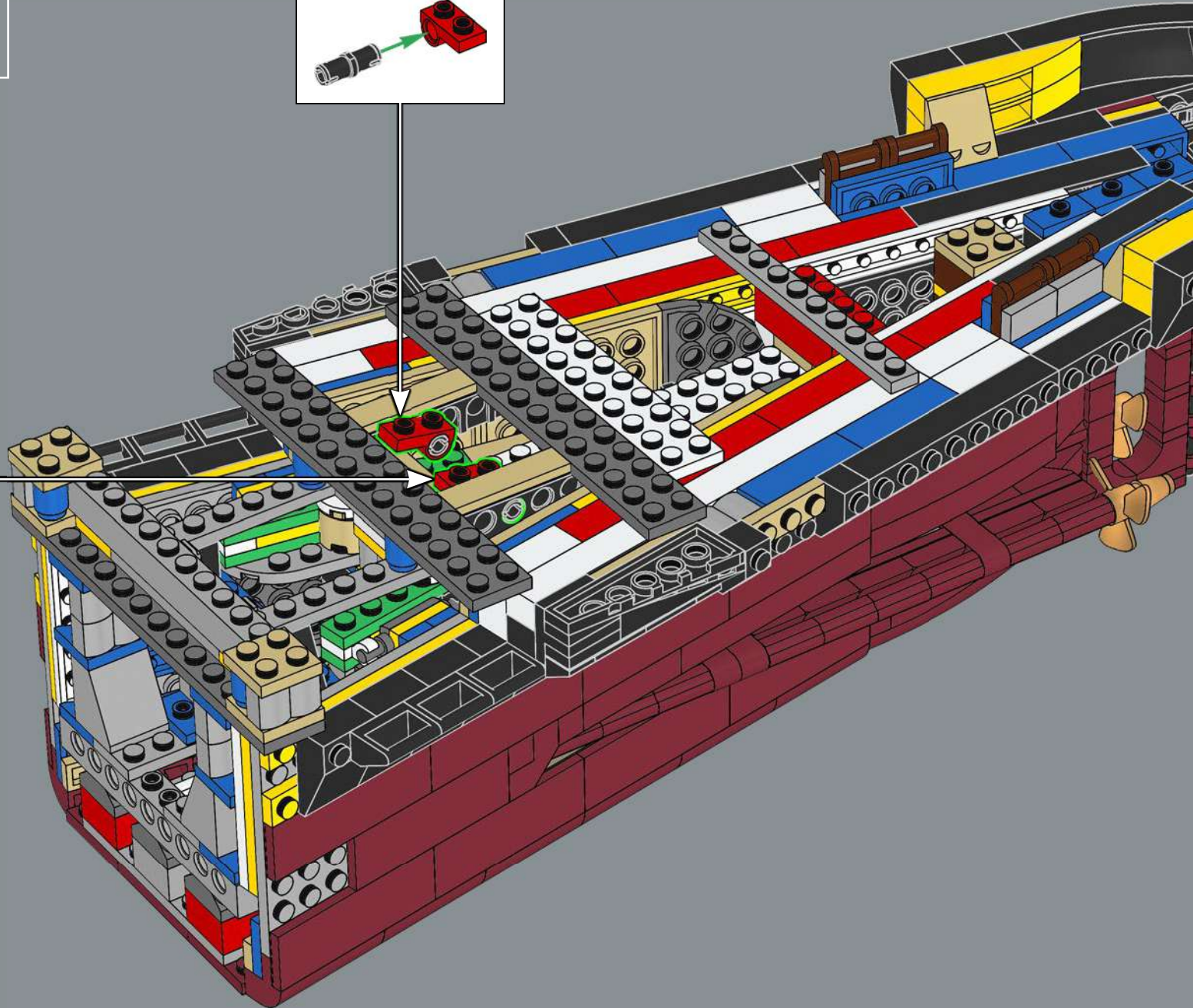
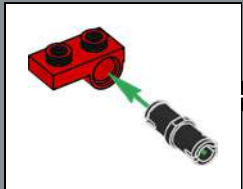
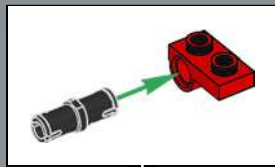

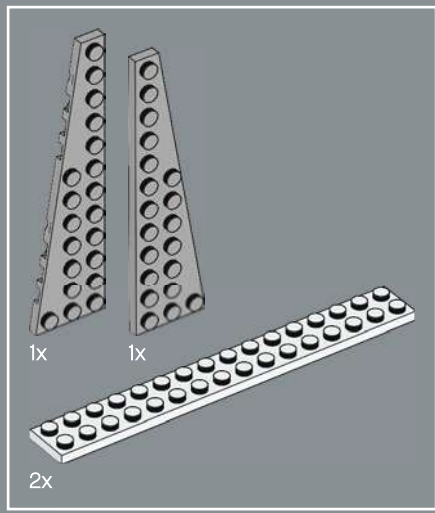

270

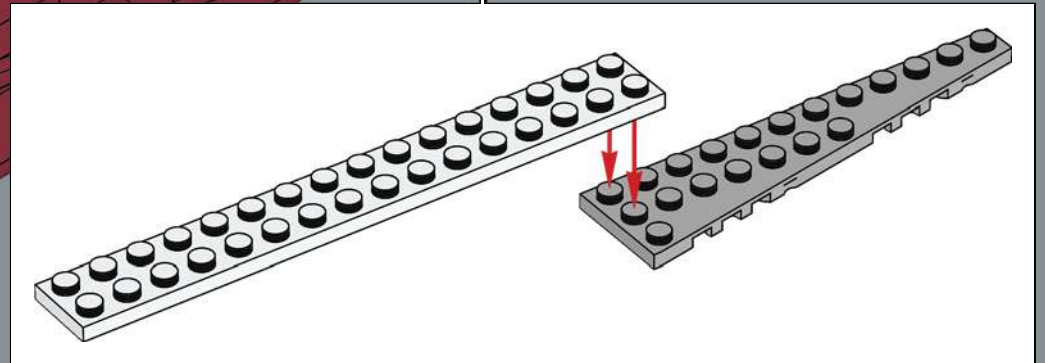
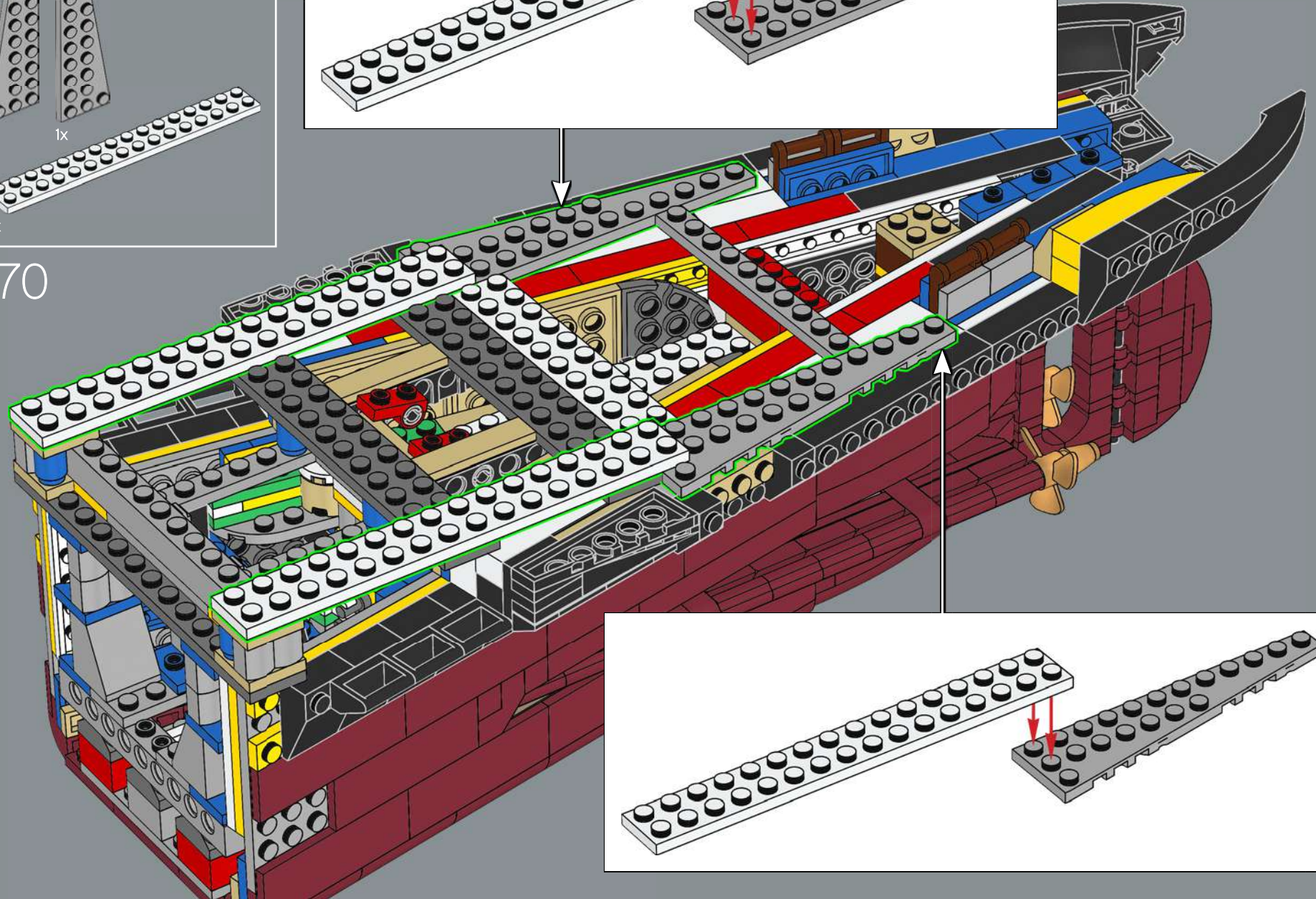
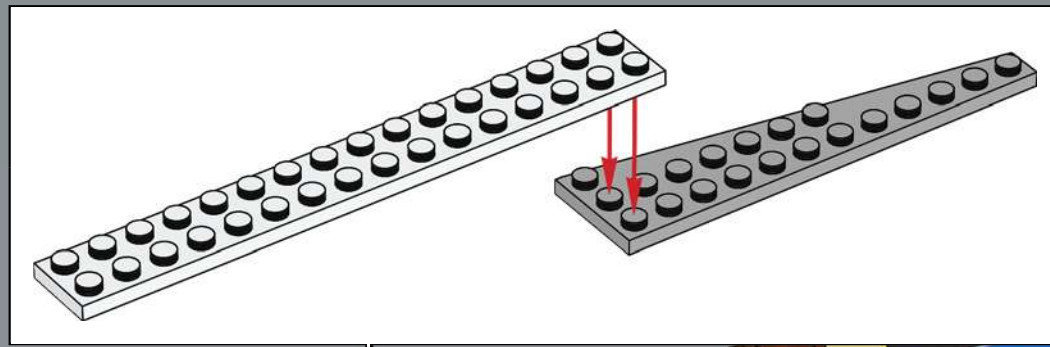

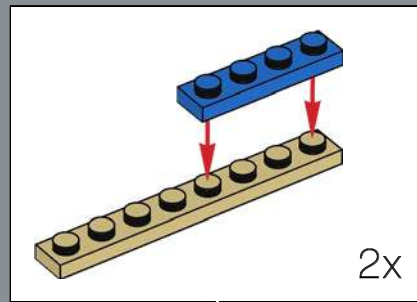
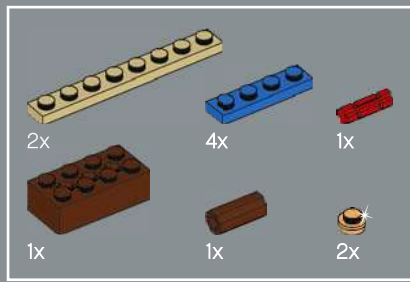

271

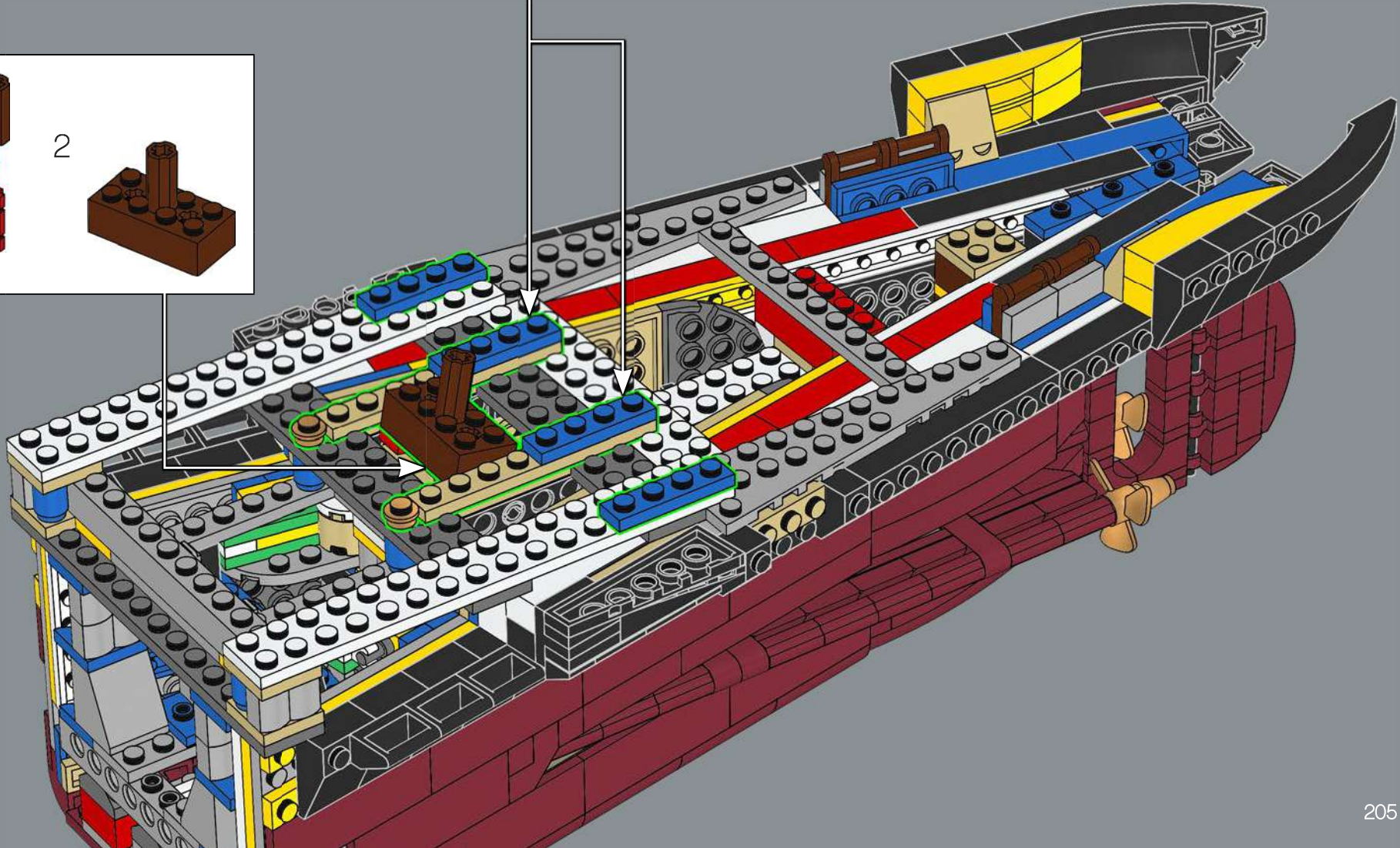
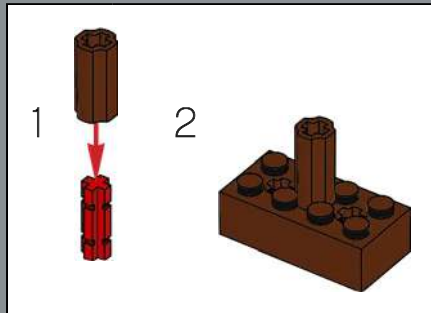

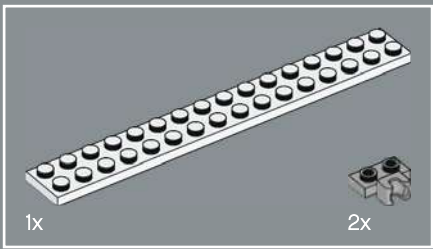

272

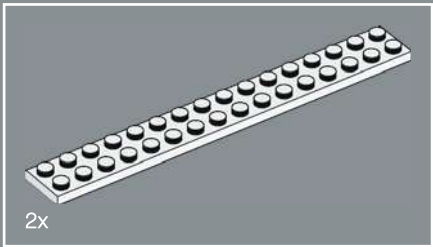
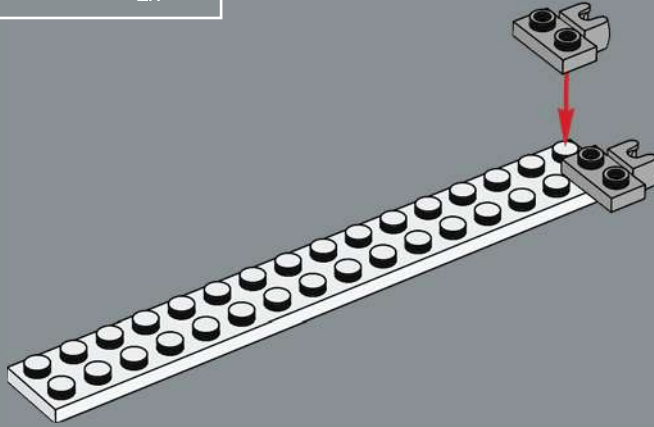

273

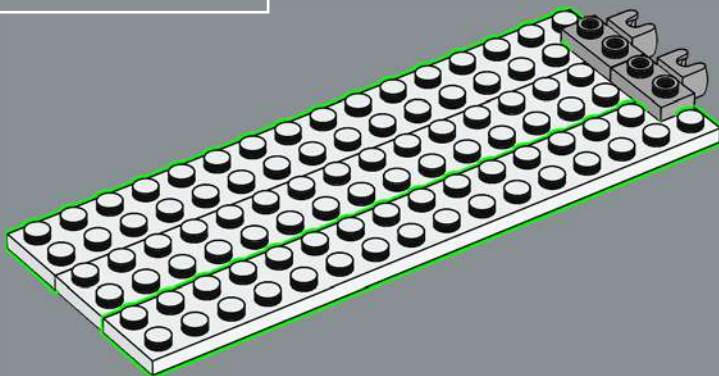

274

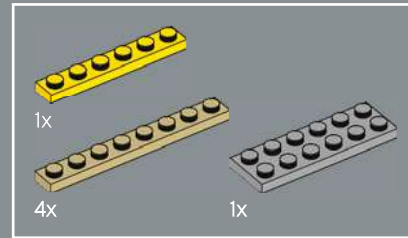
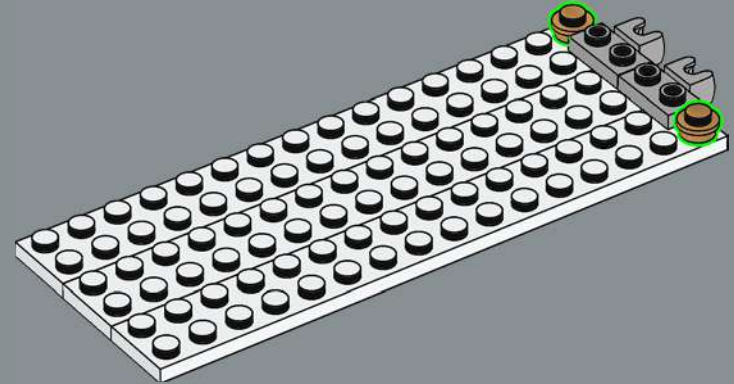

275

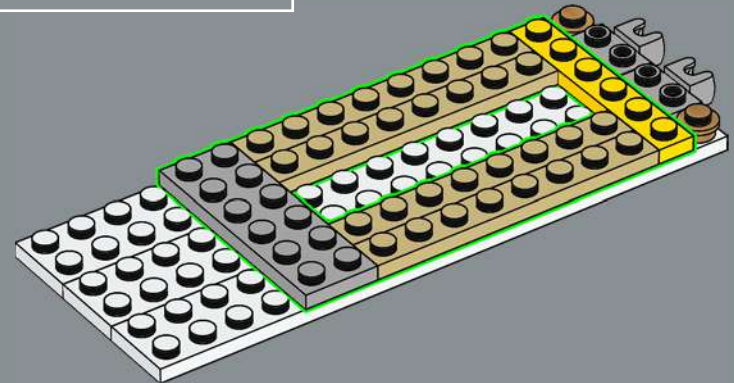

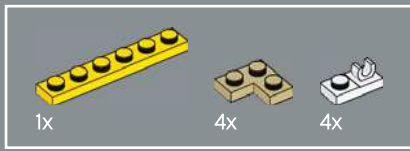

276

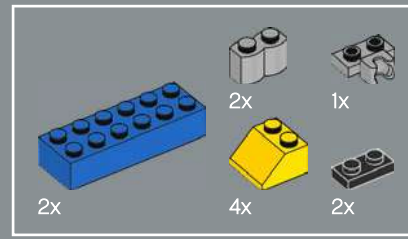
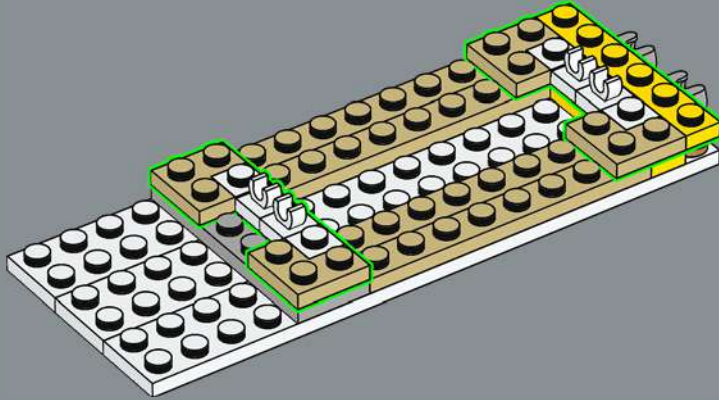

277

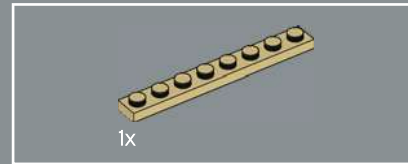
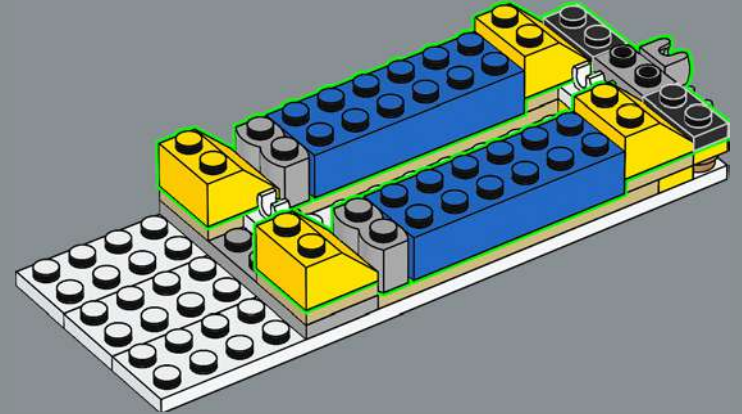

278

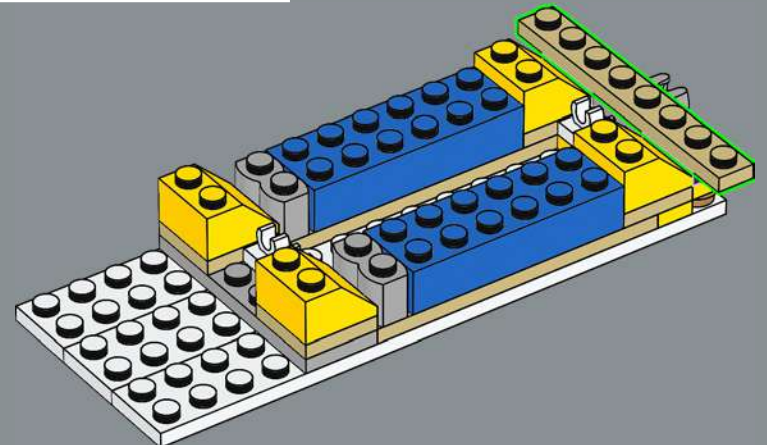

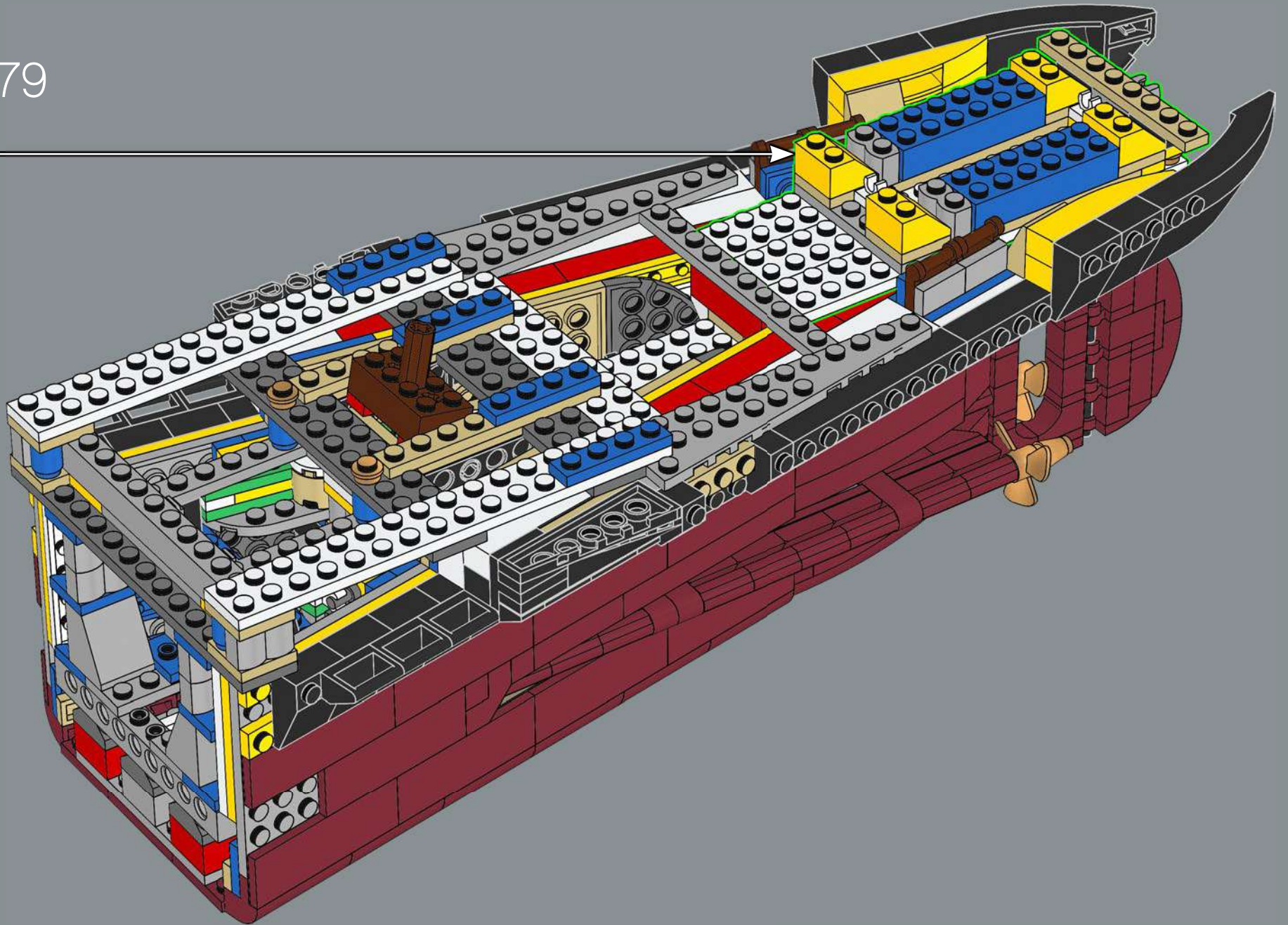

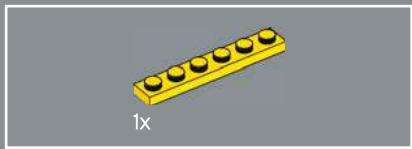

284

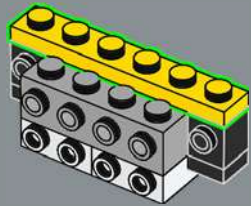

285

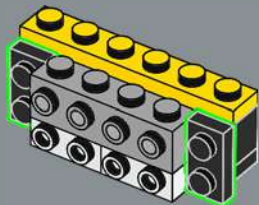

286

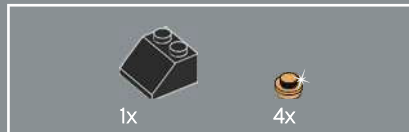
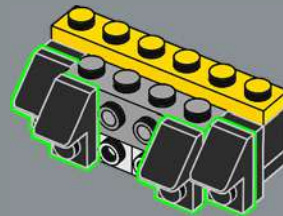

287

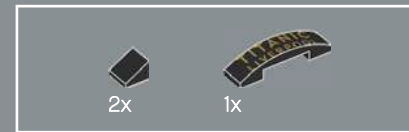
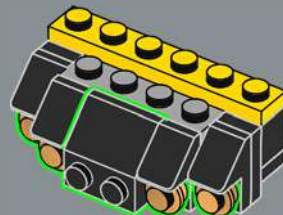

288

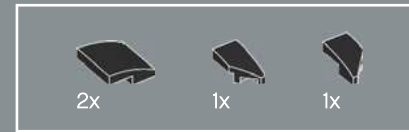
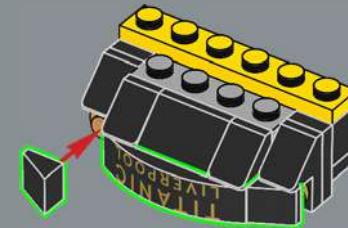

289

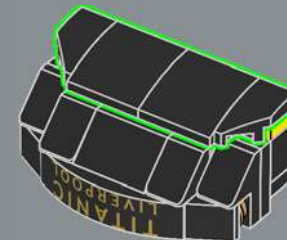

The *Titanic* lacked a searchlight and had no Public Address system.

290

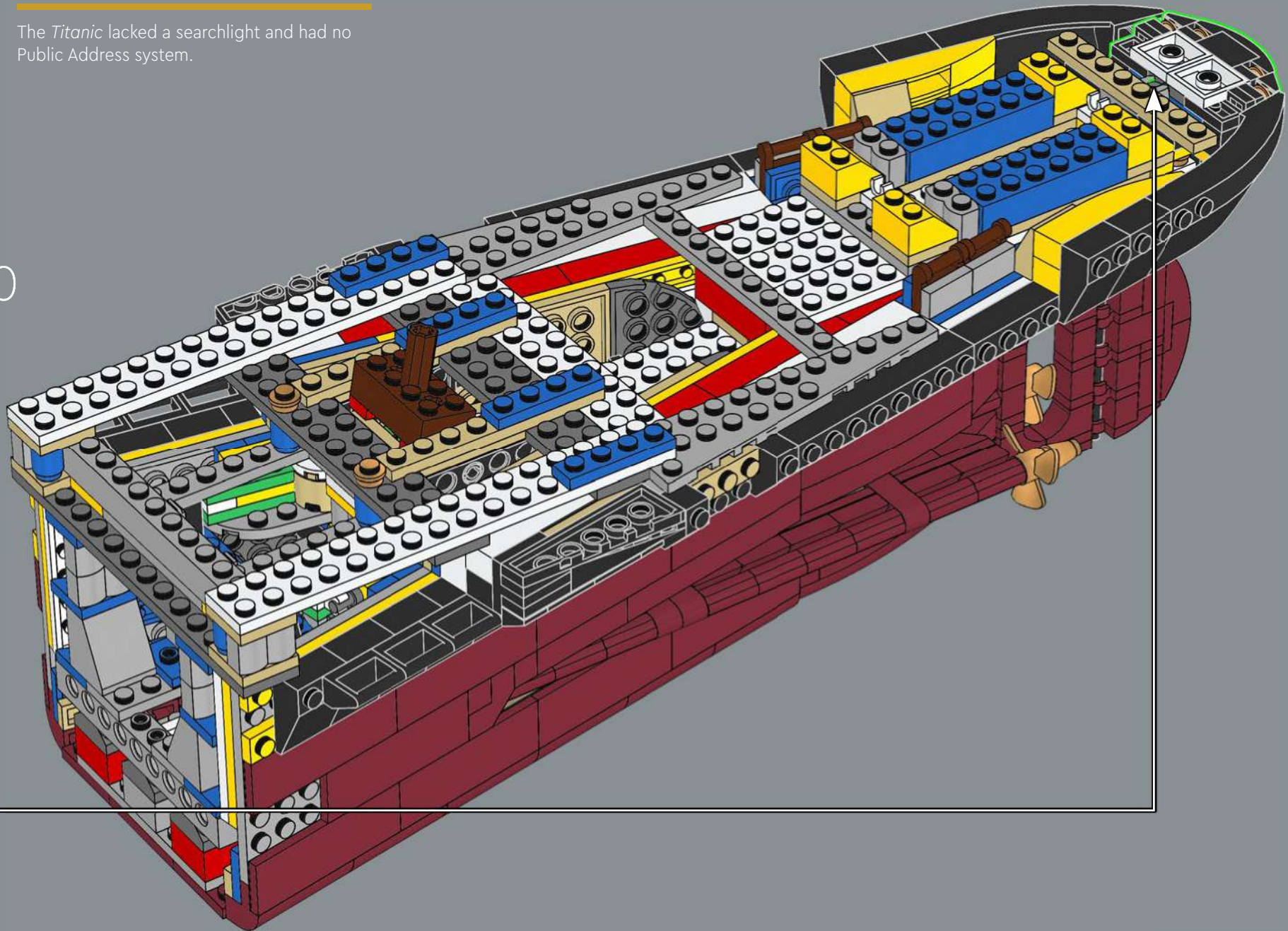

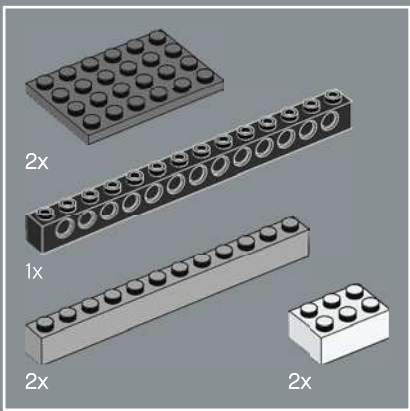

291

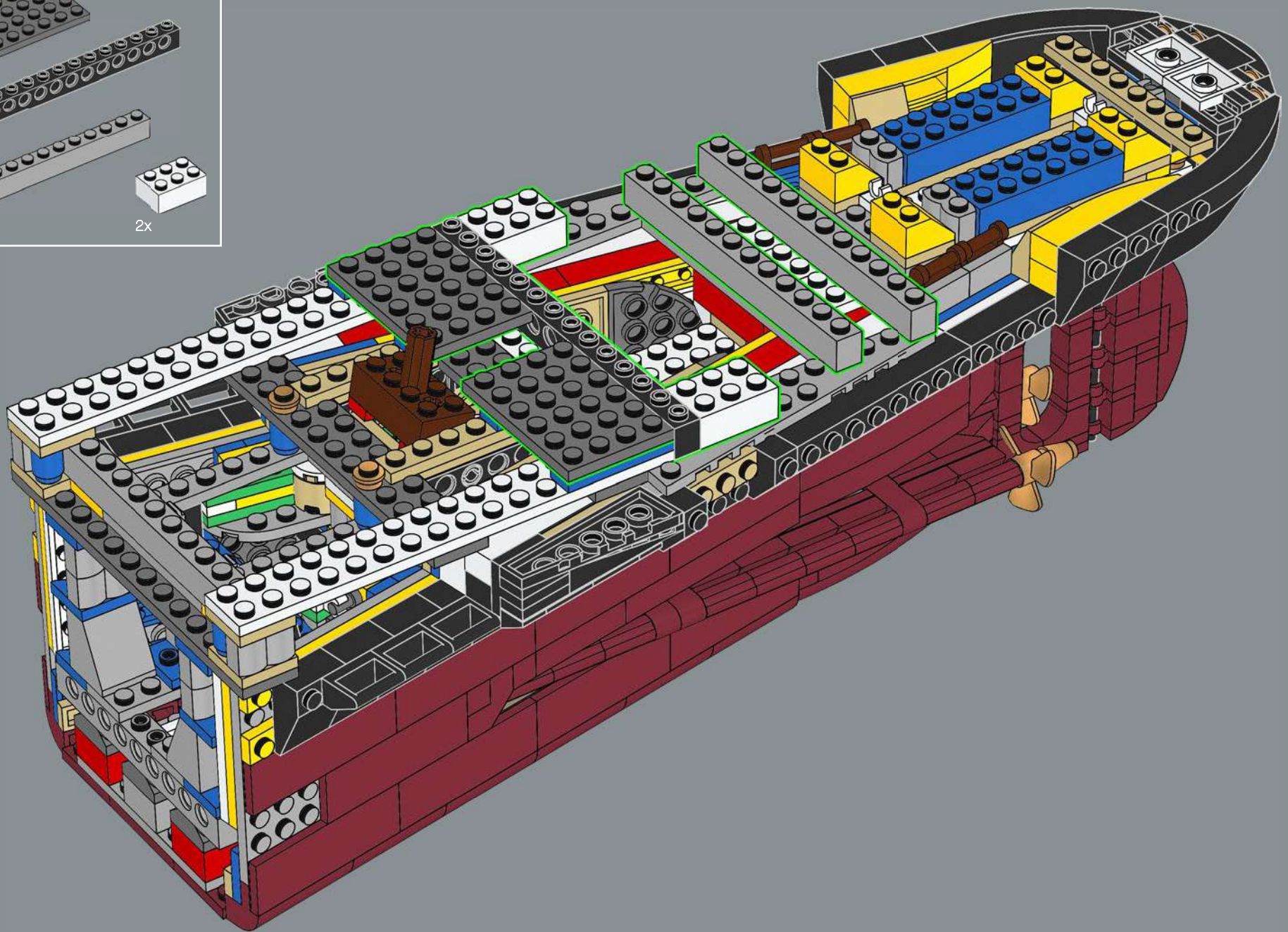

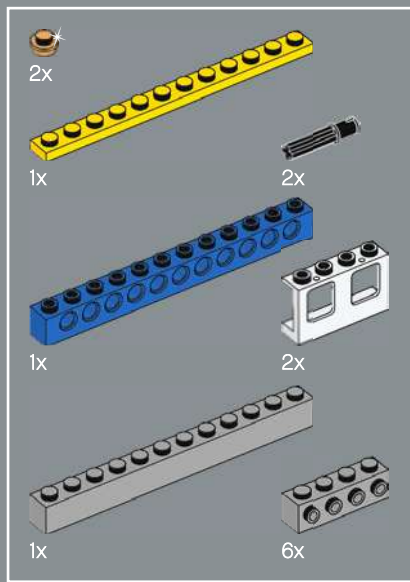

292

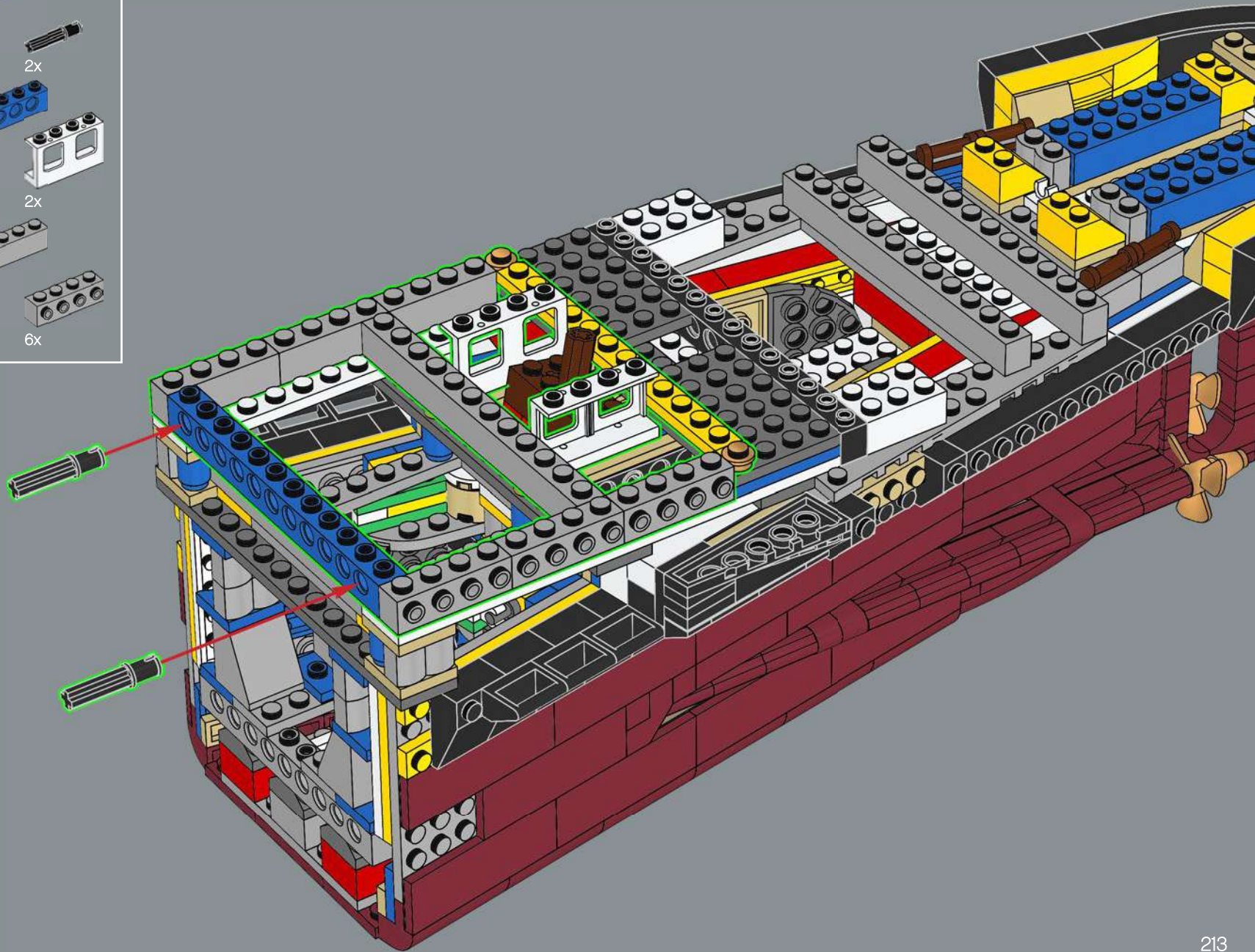

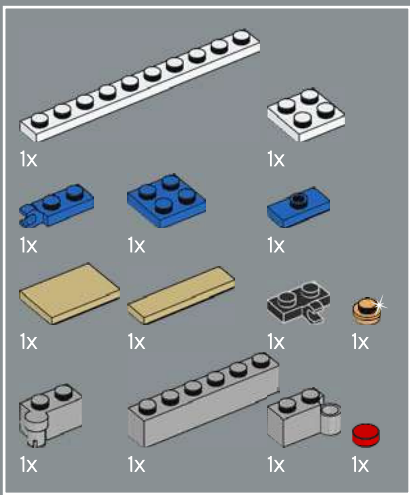

293

1

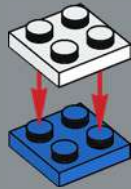

2

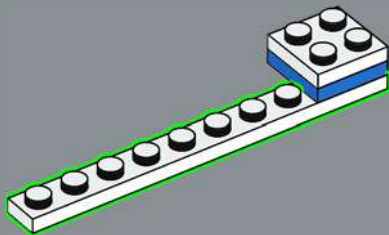

3

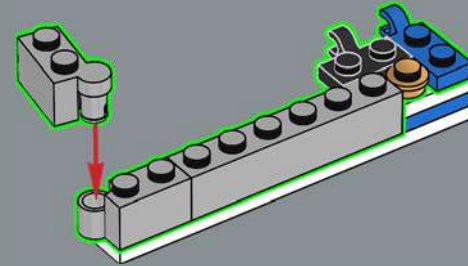

4

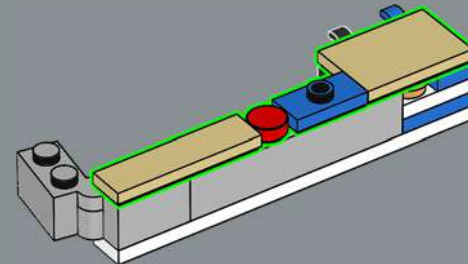

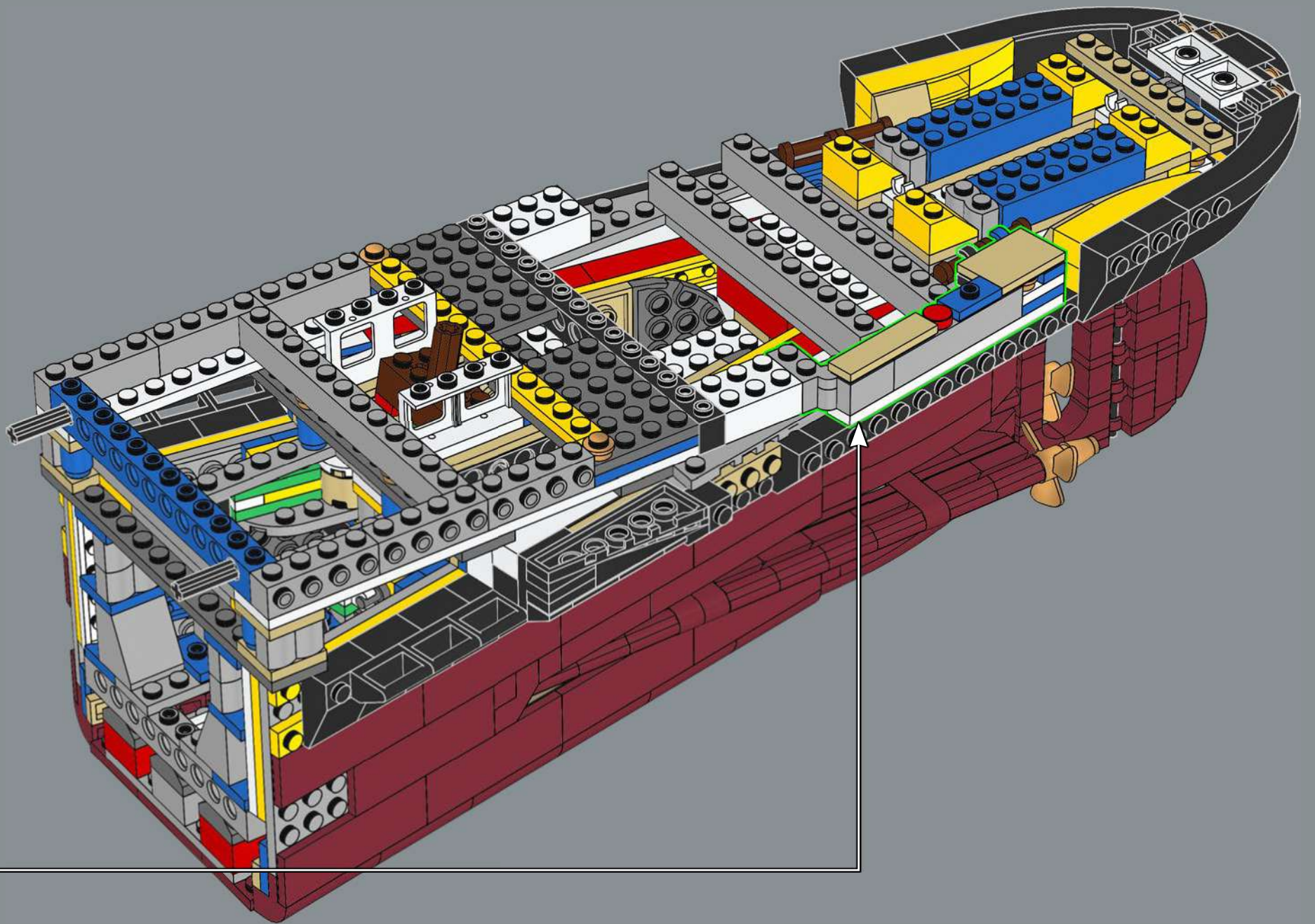

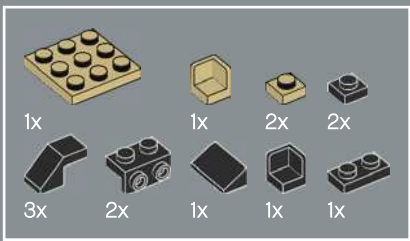

294

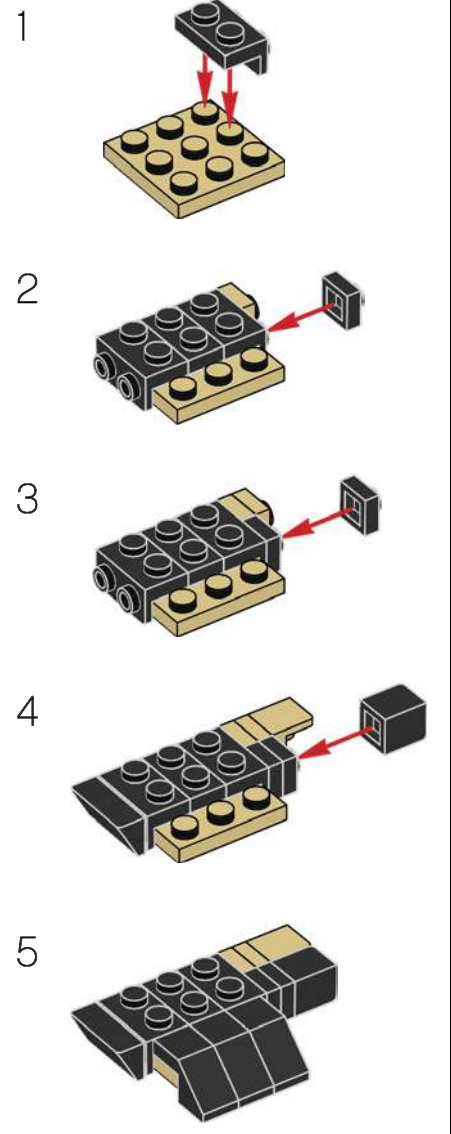
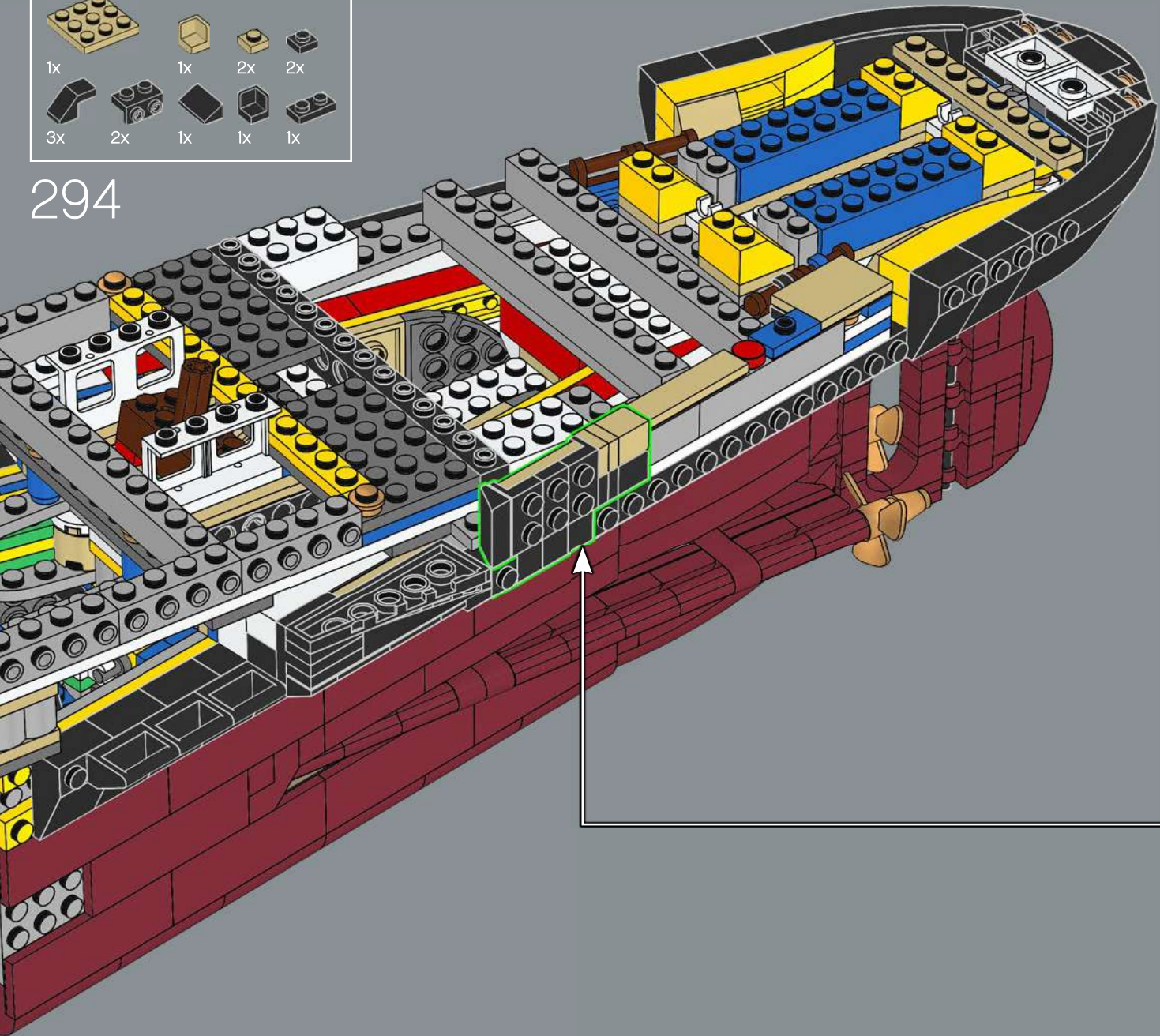

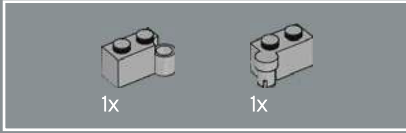
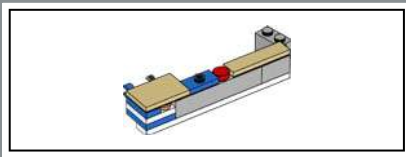

295

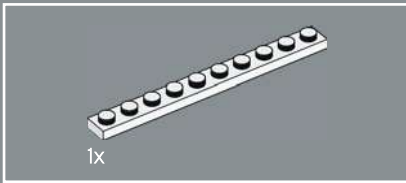
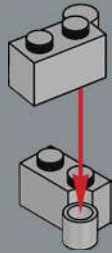

296

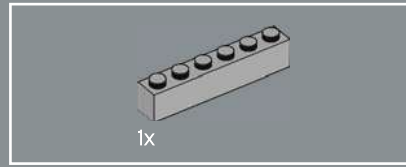
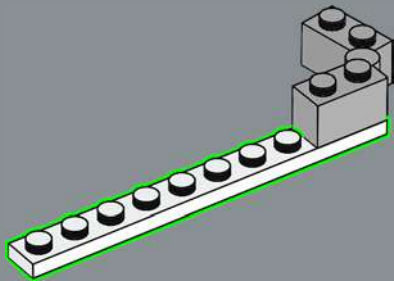

297

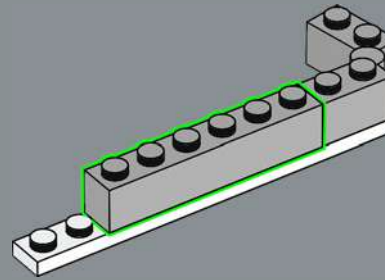

298

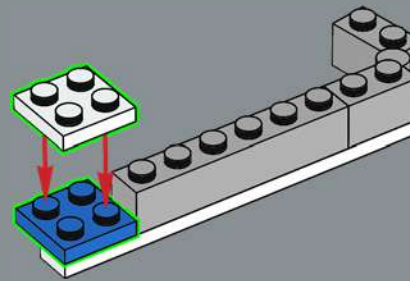

299

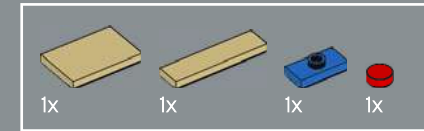
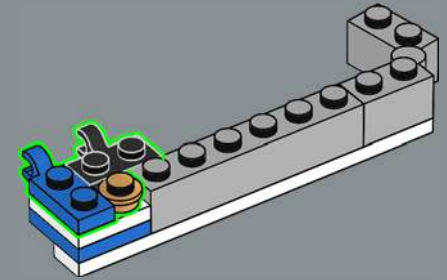

300

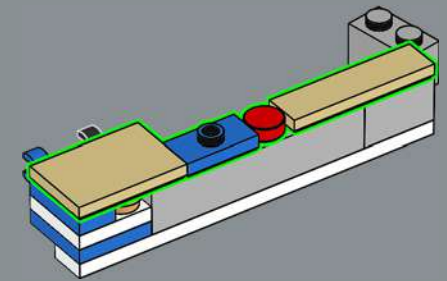

301

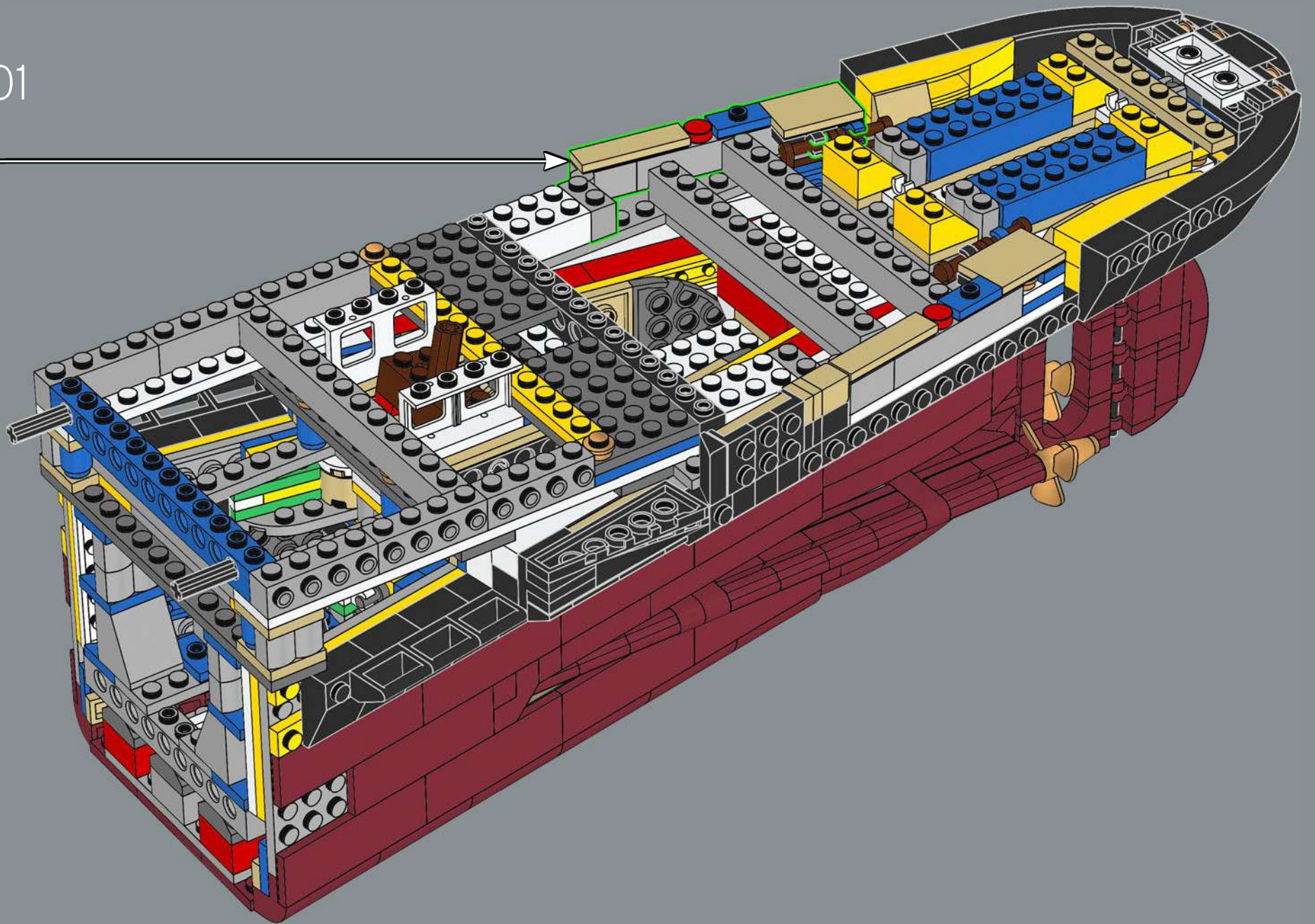

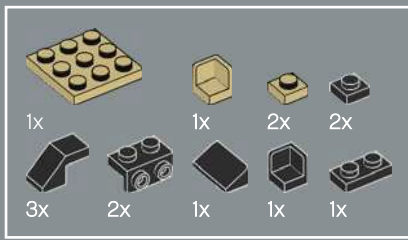

302

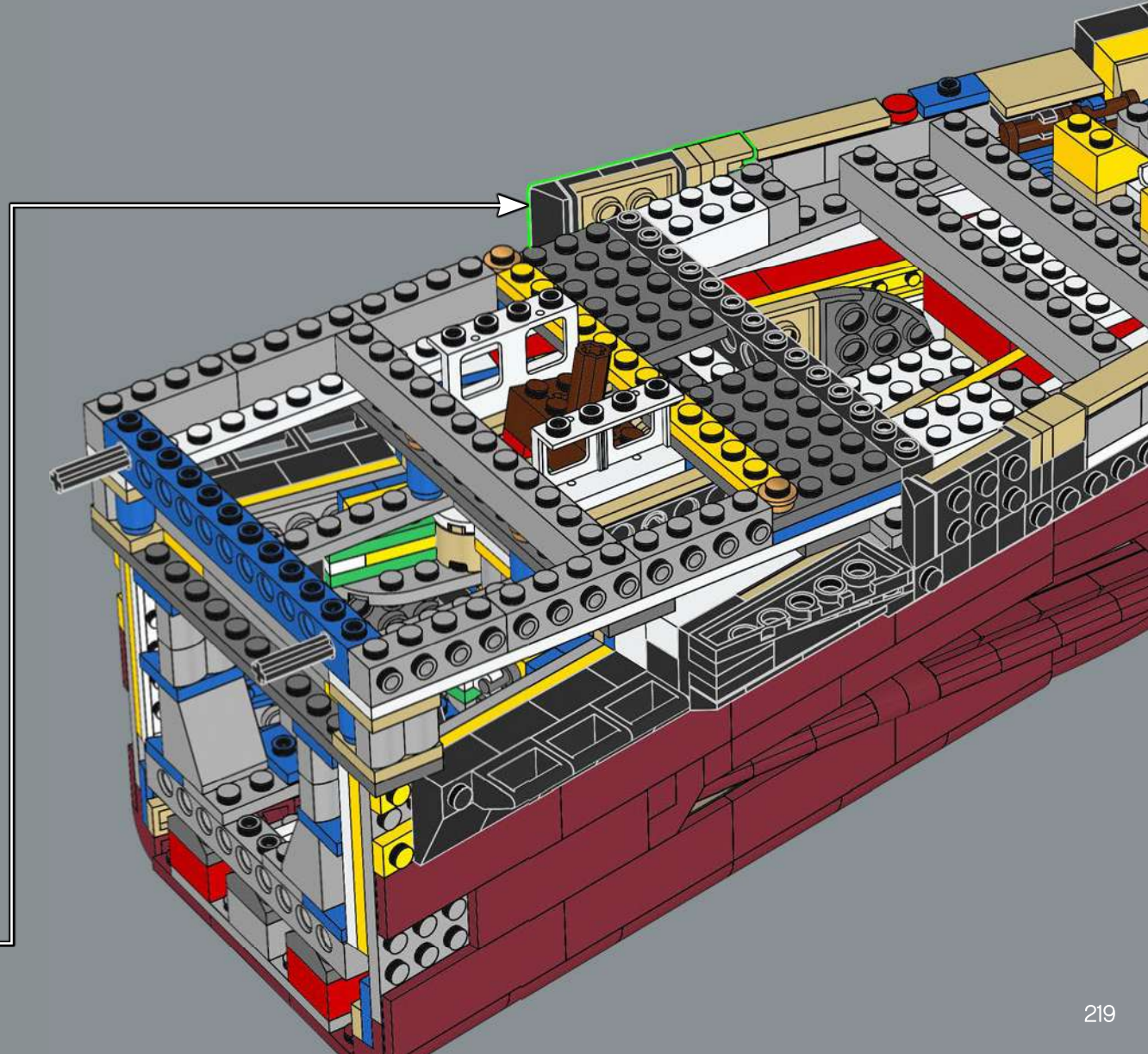
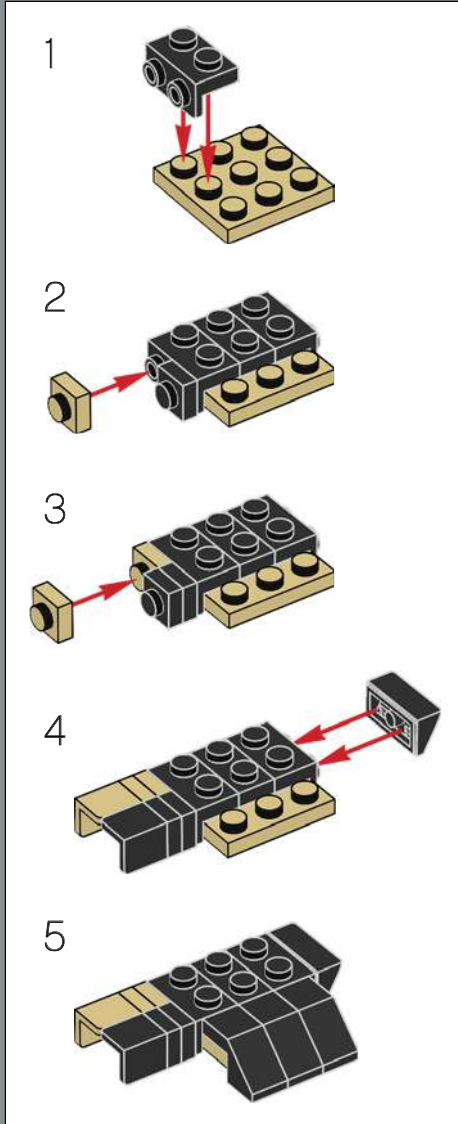

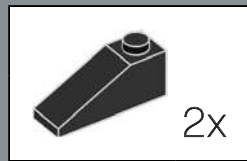
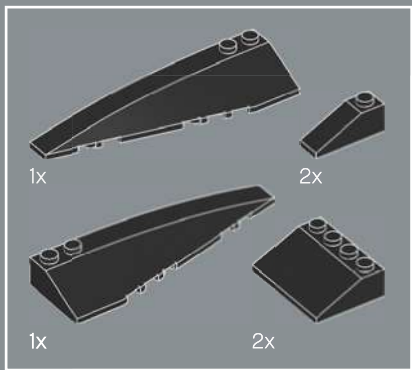

303

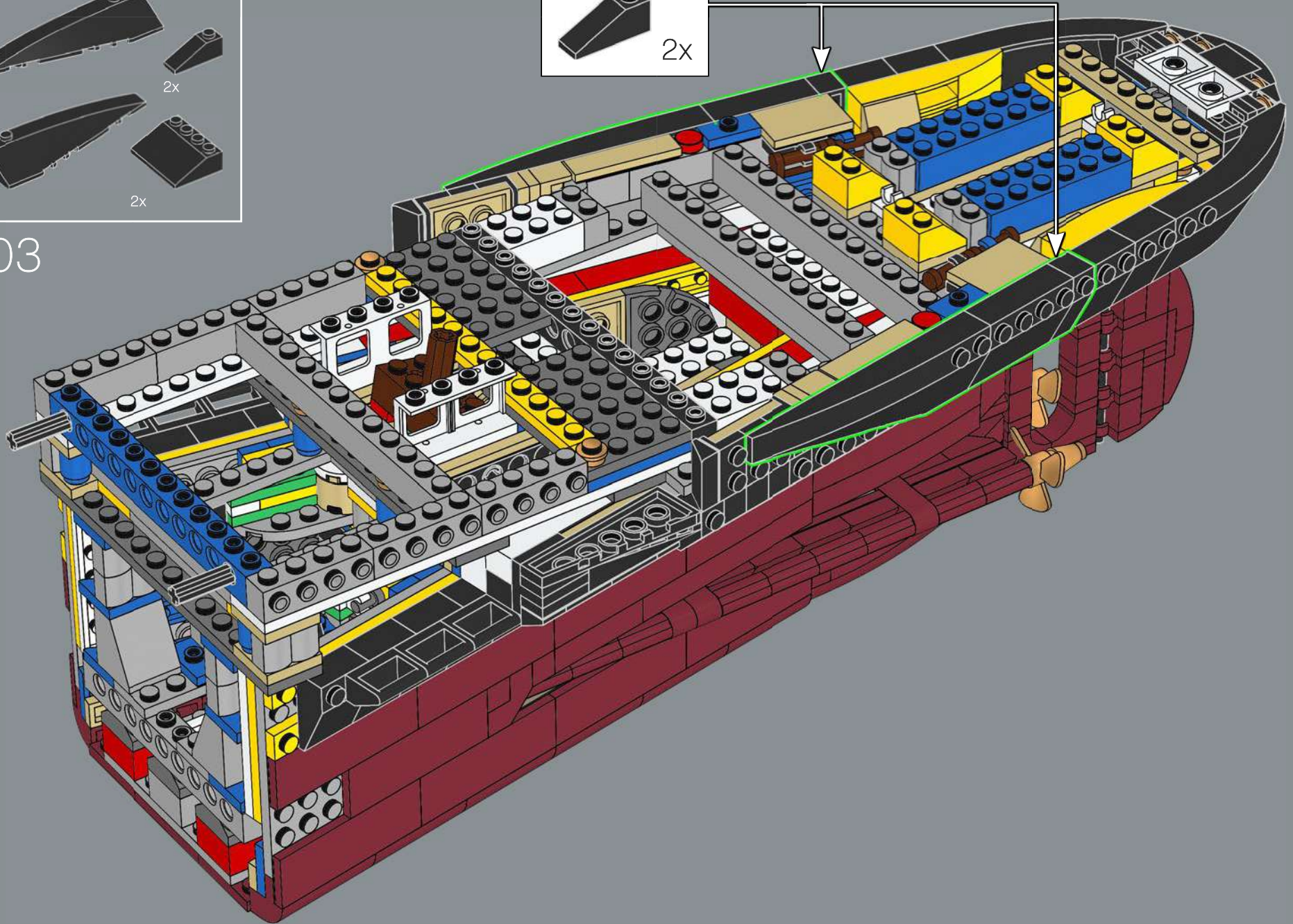

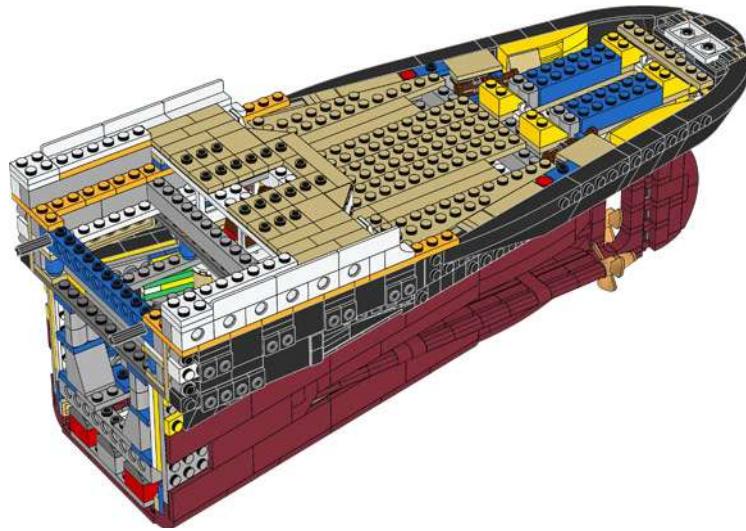
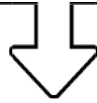

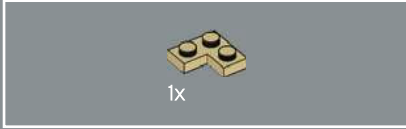
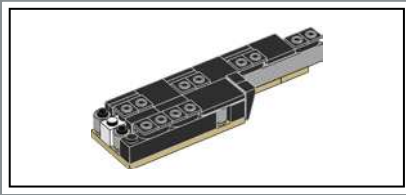

305

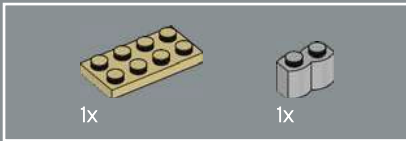

306

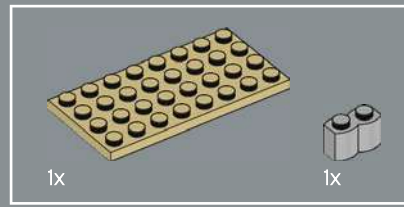
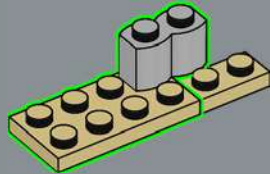

307

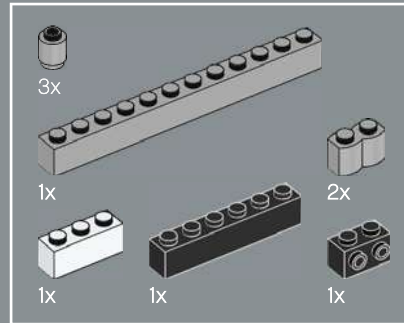
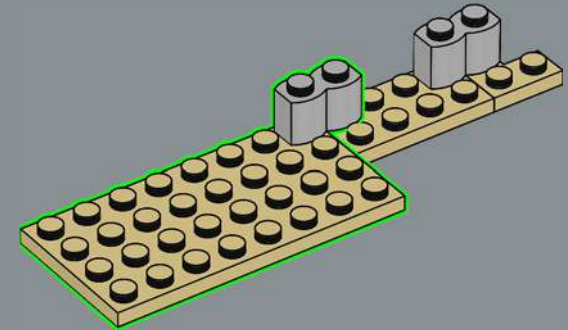

308

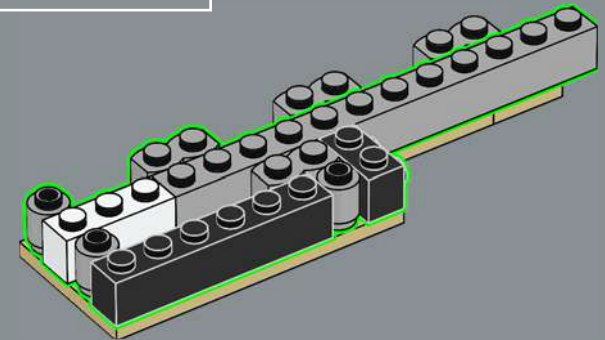

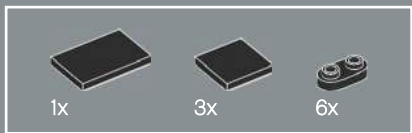

309

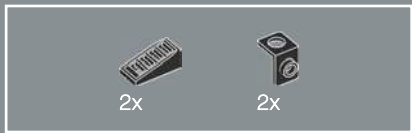
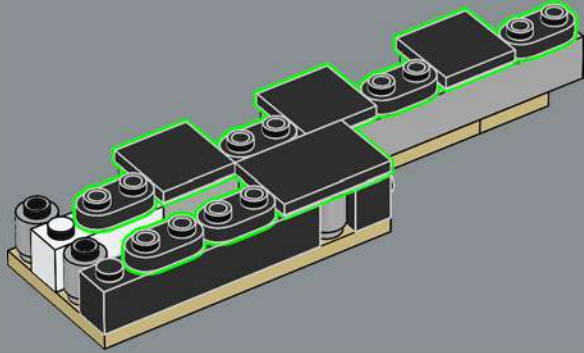

310

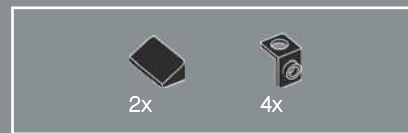
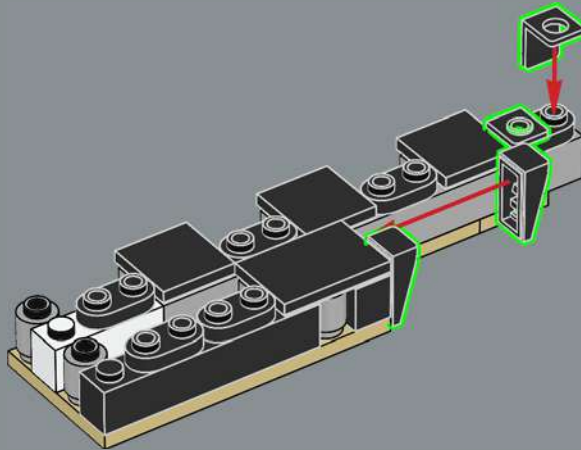

311

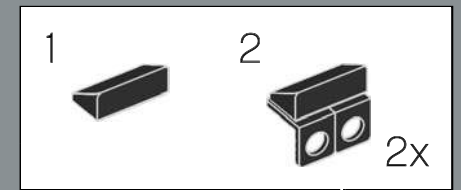
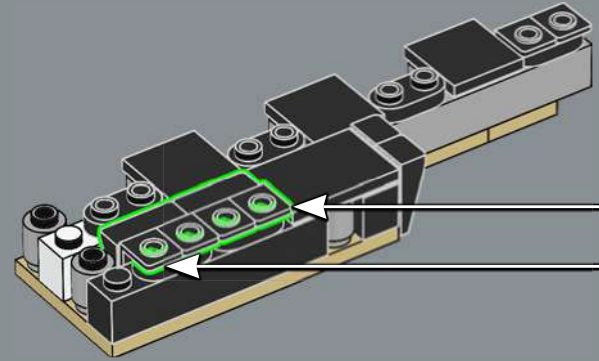

312

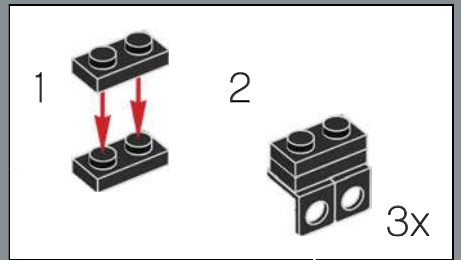
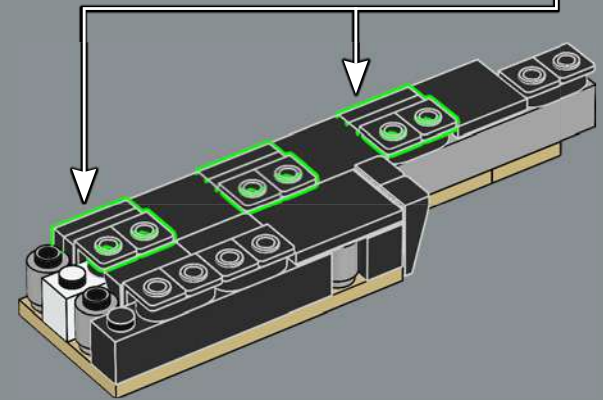

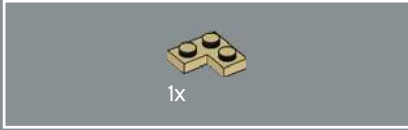
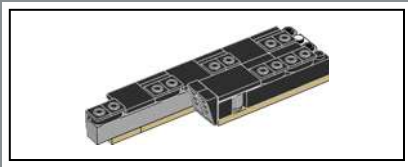

314

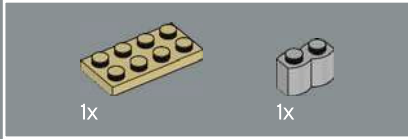
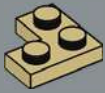

315

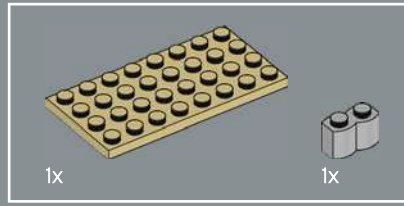
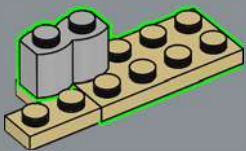

316

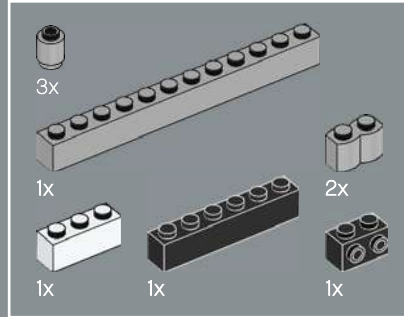
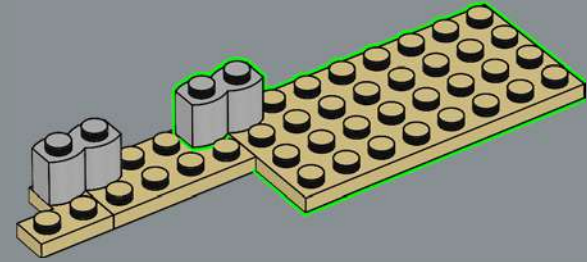

317

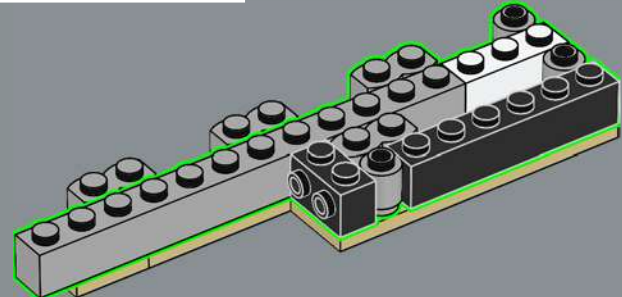

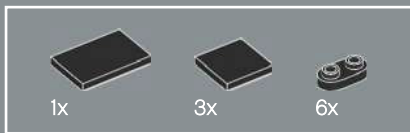

318

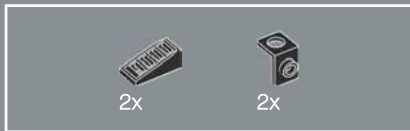
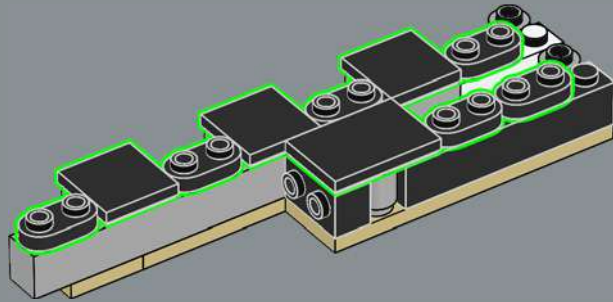

319

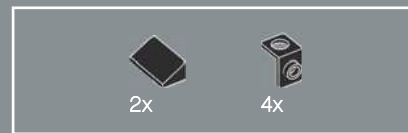
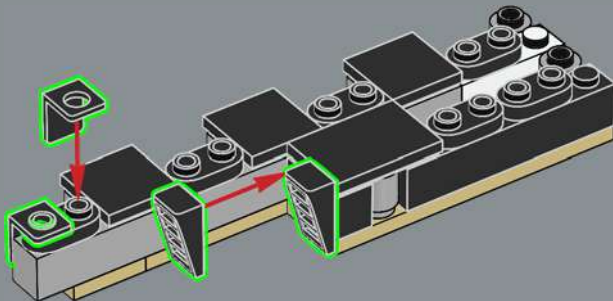

320

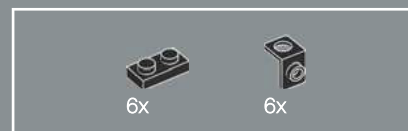
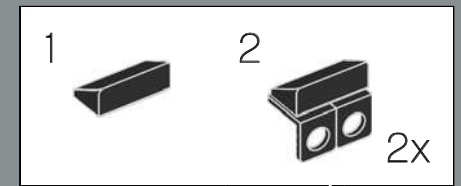
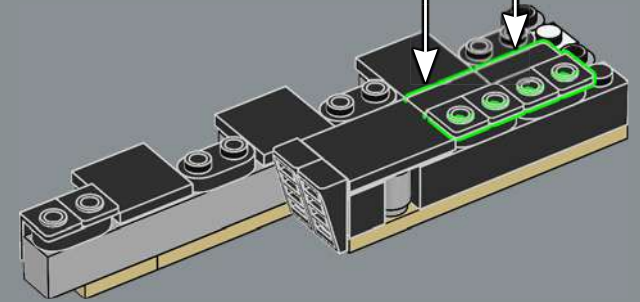

321

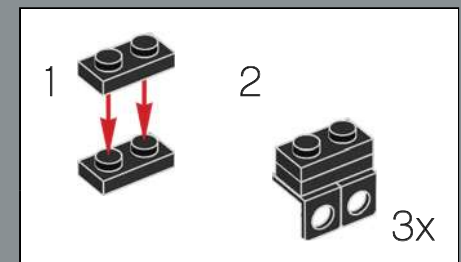
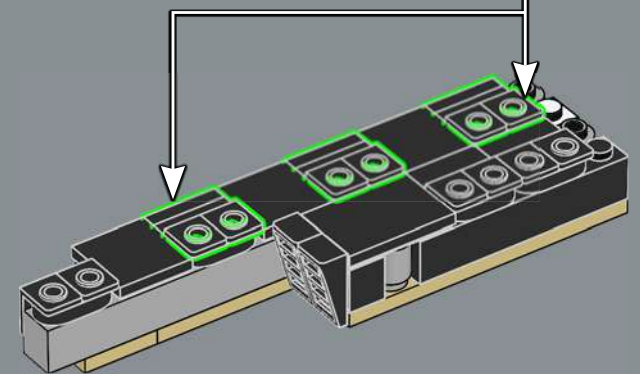

322

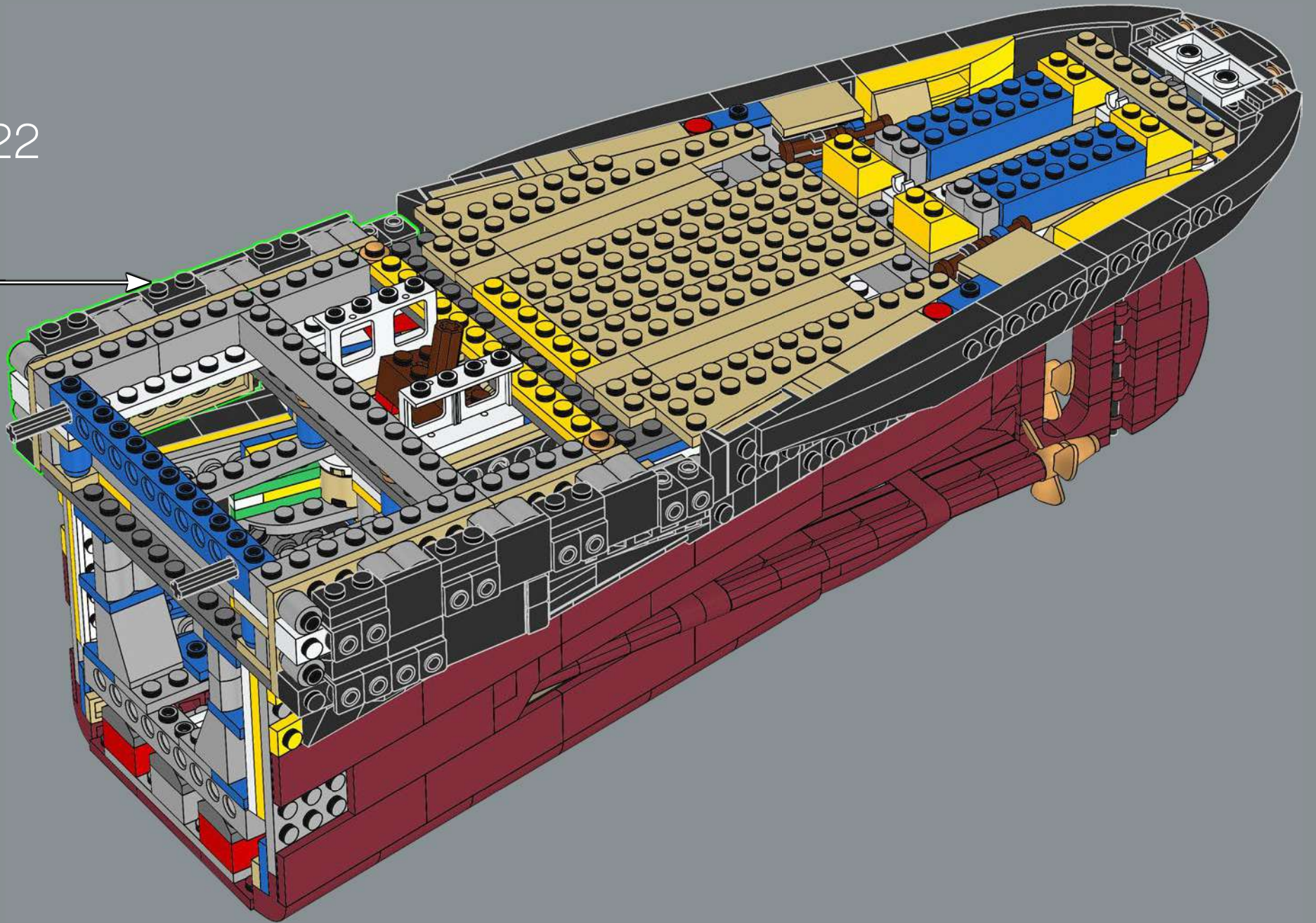

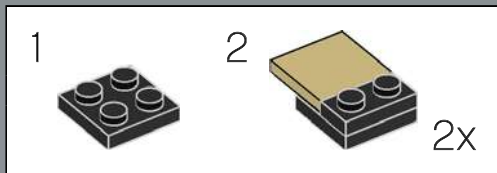
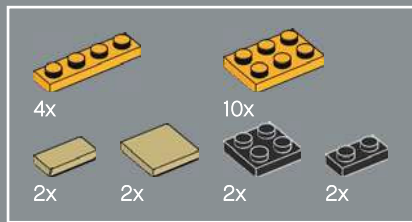

323

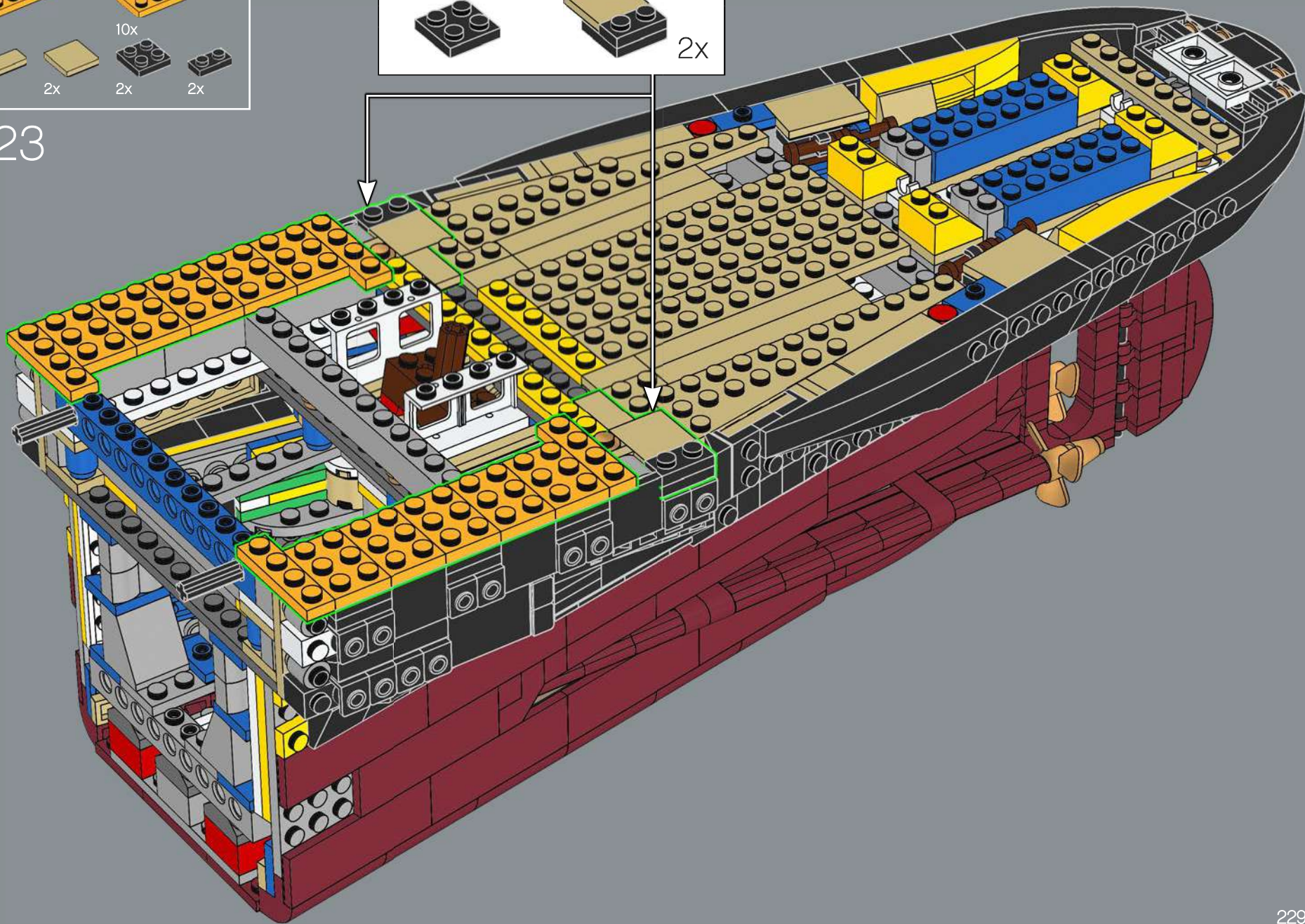

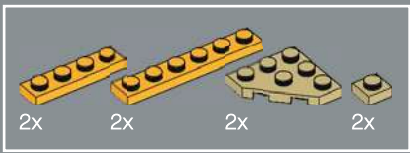

324

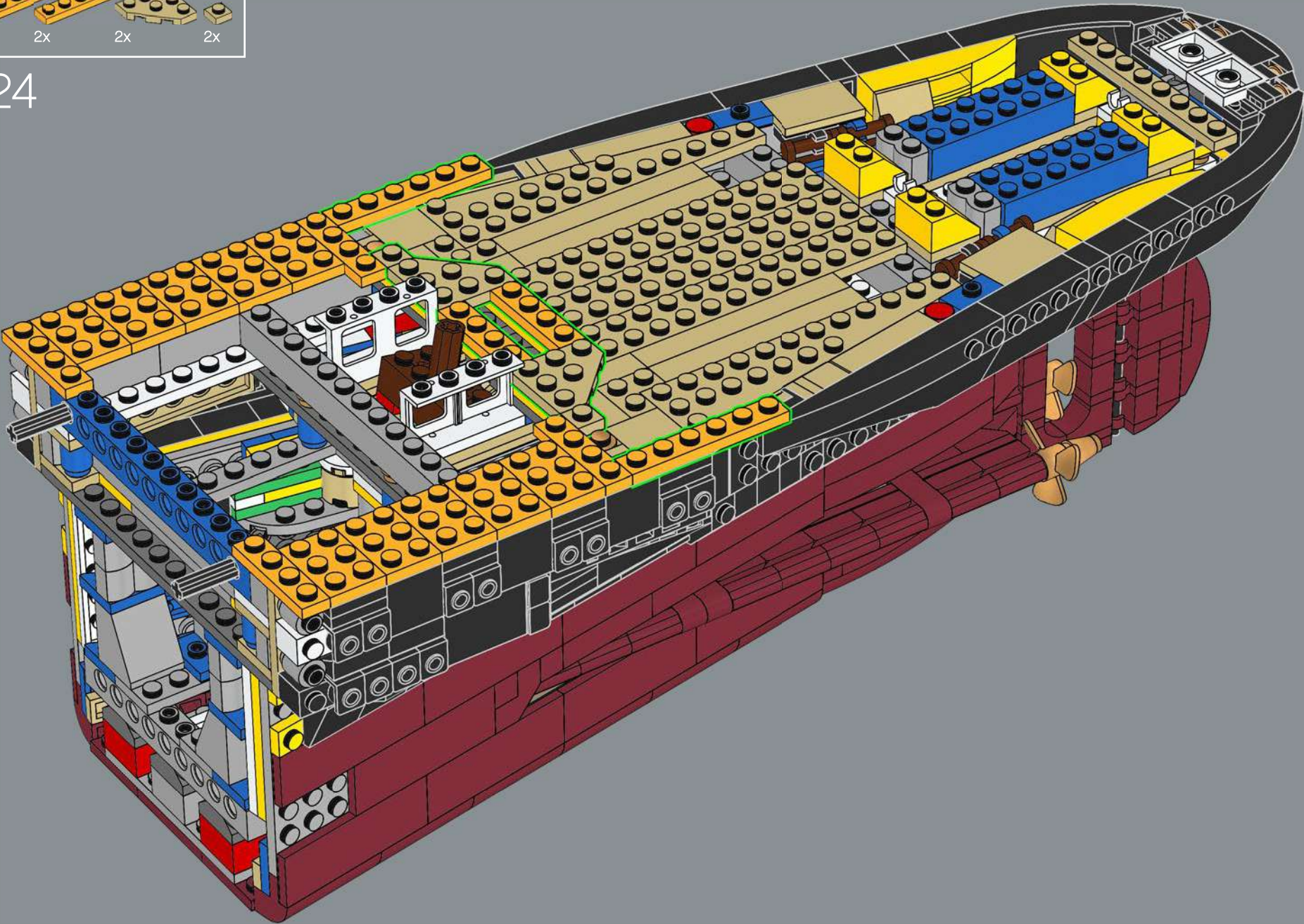

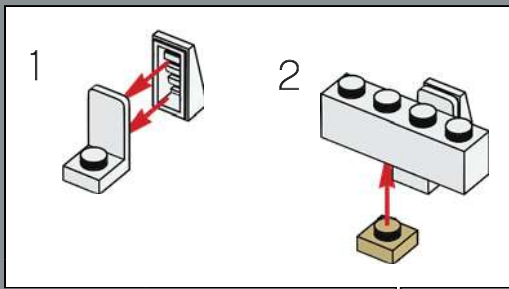
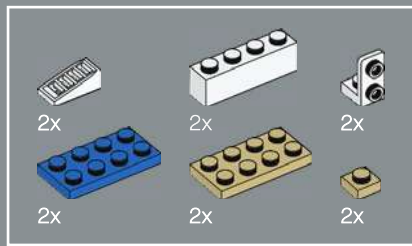

325

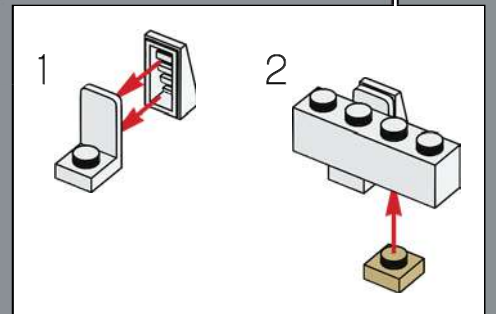
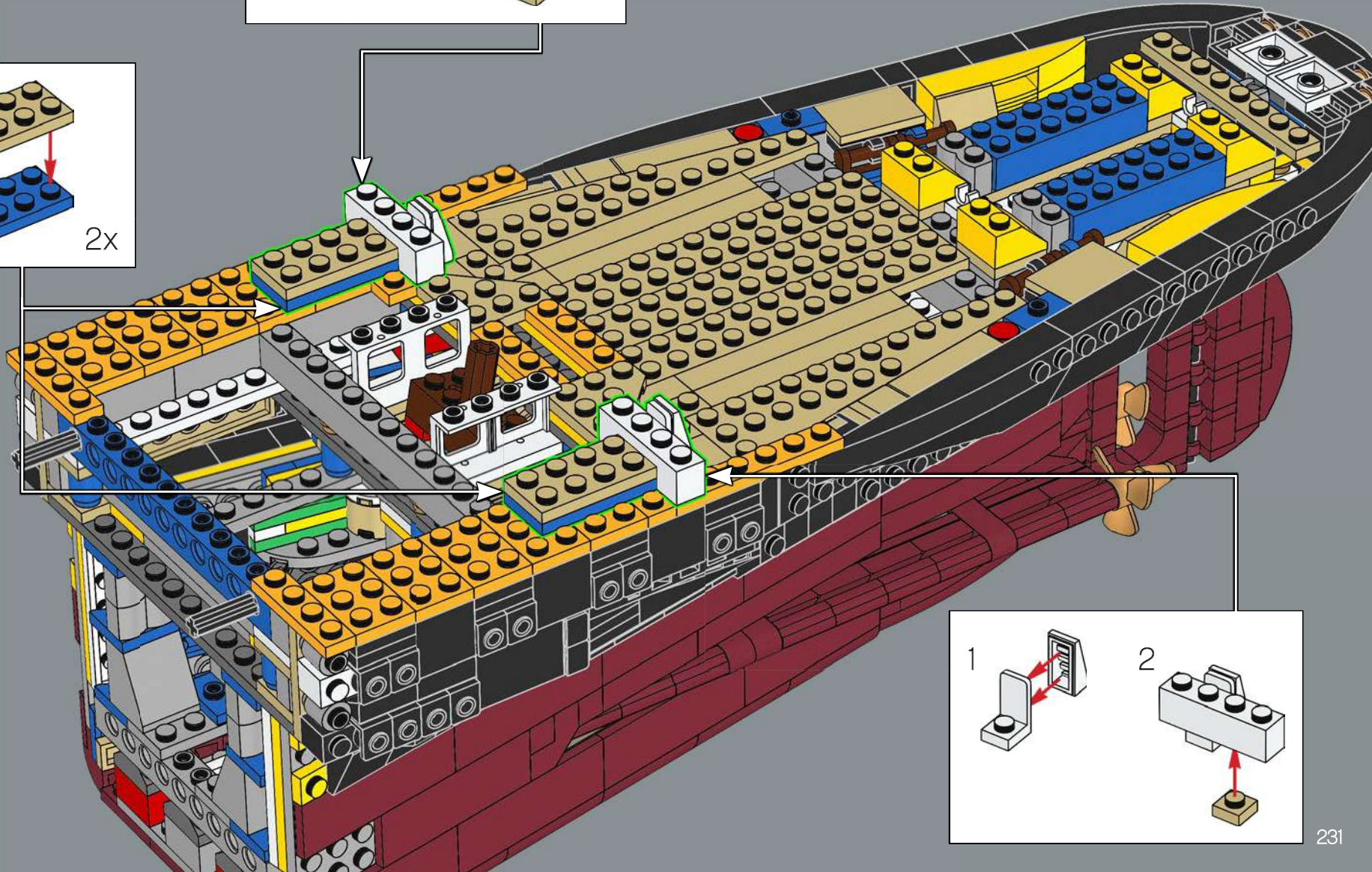
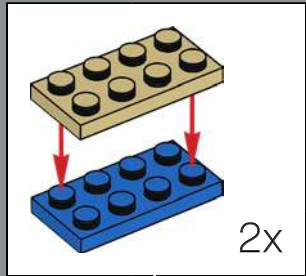

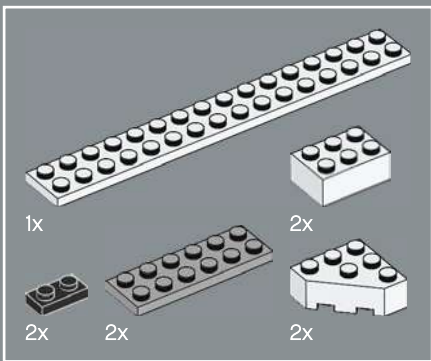

326

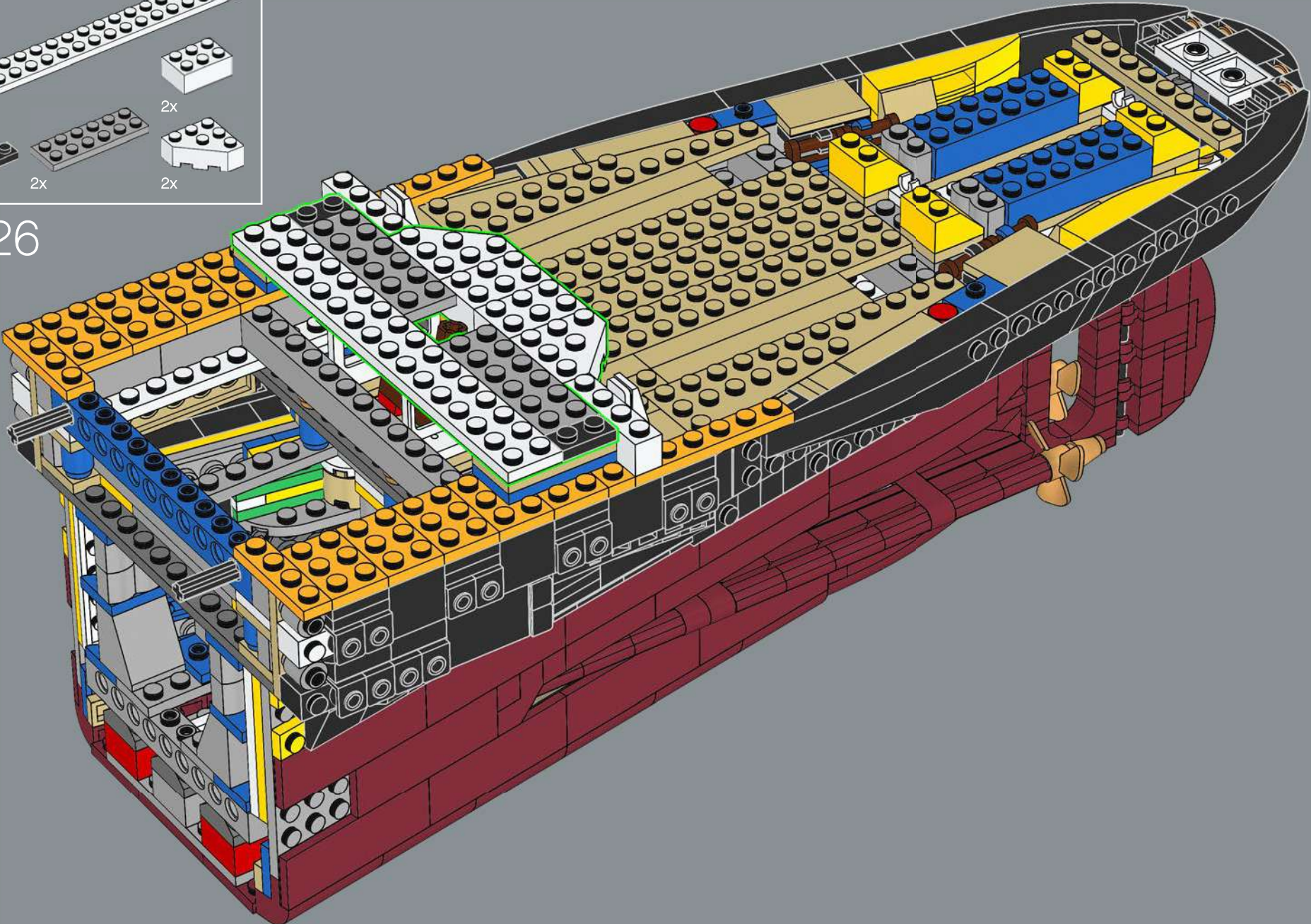

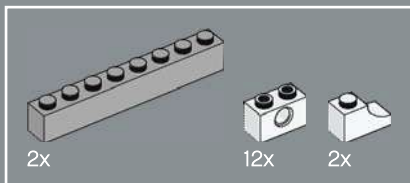

327

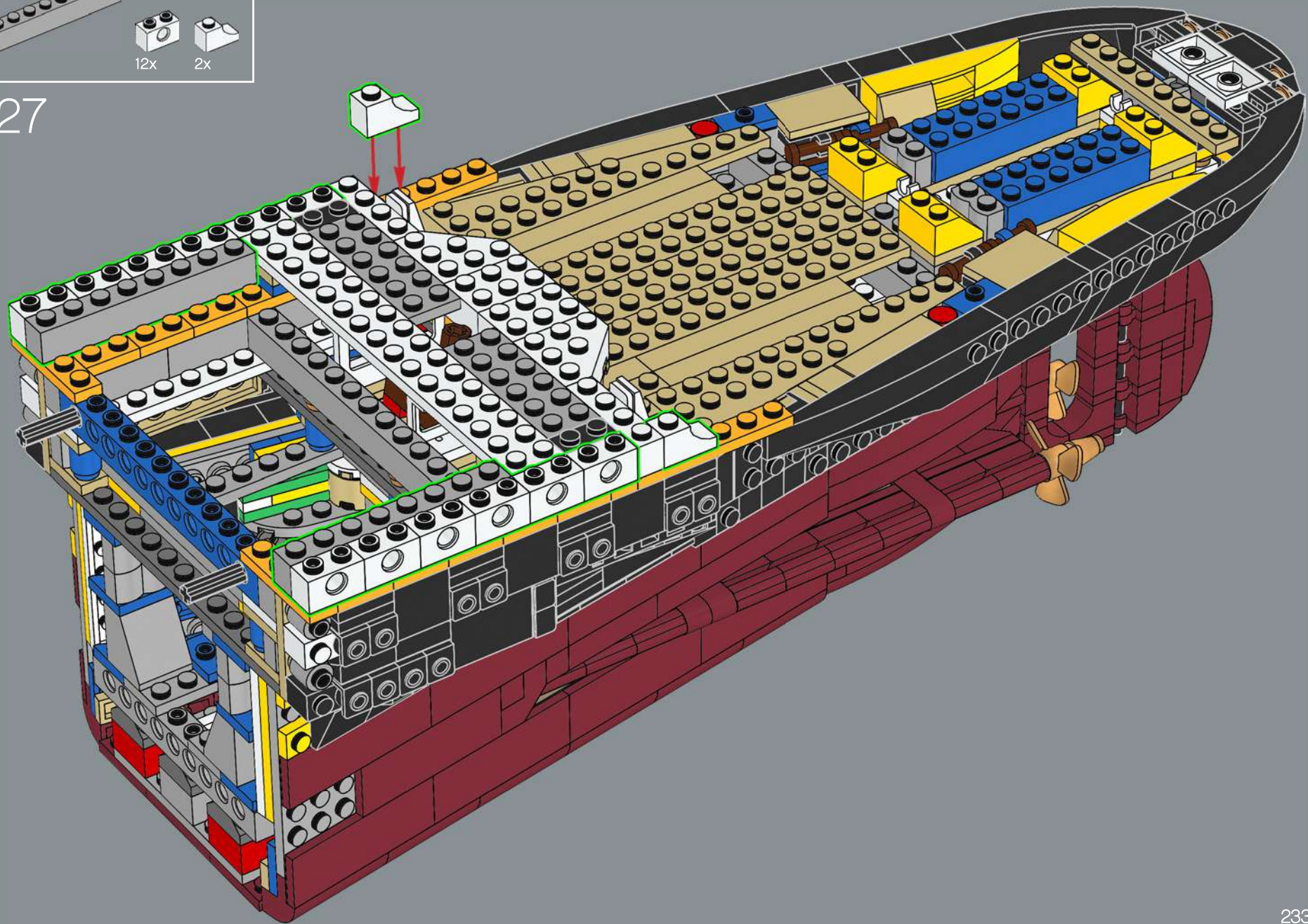

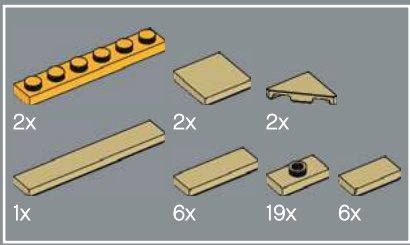

328

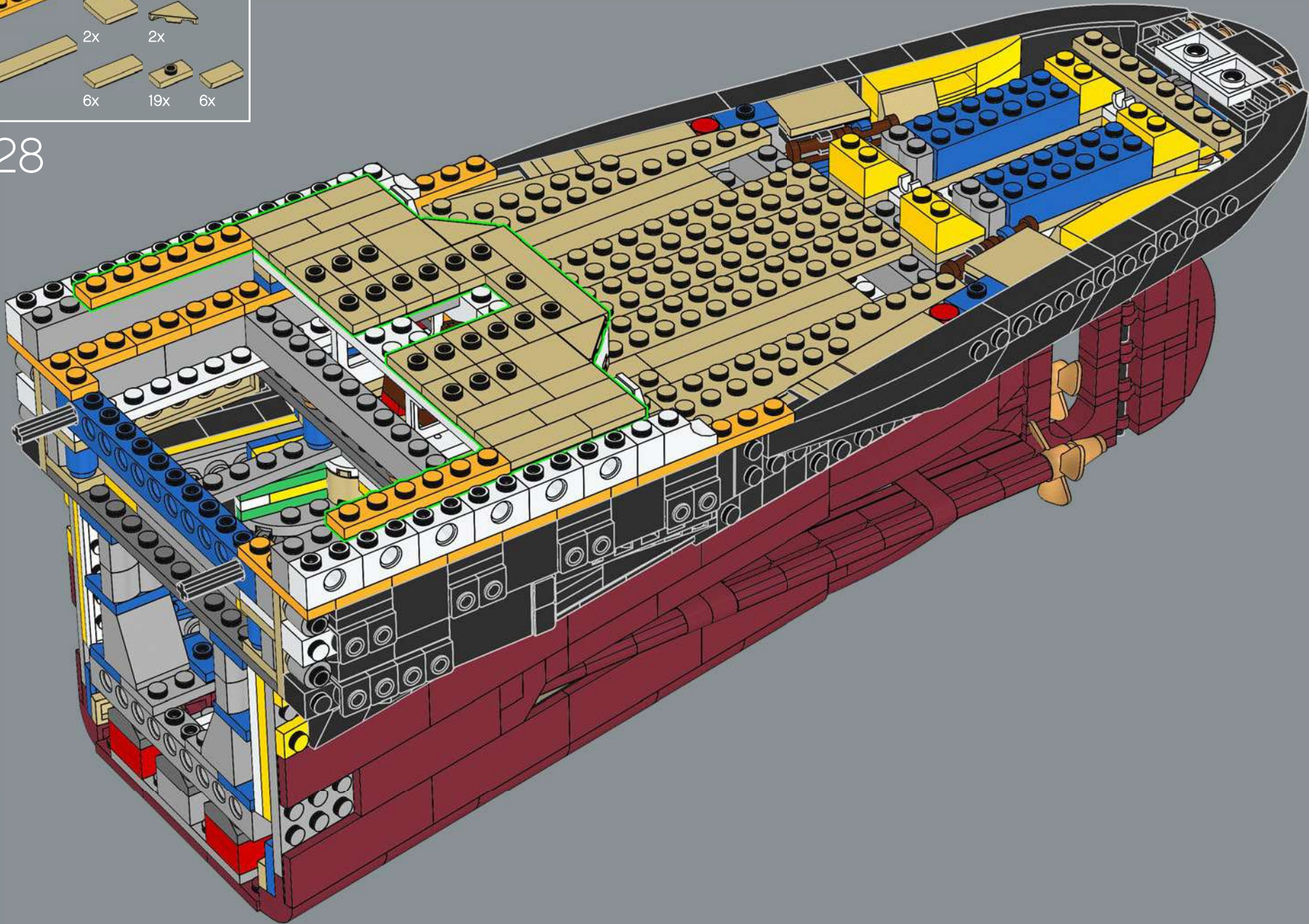

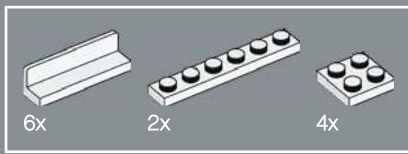

329

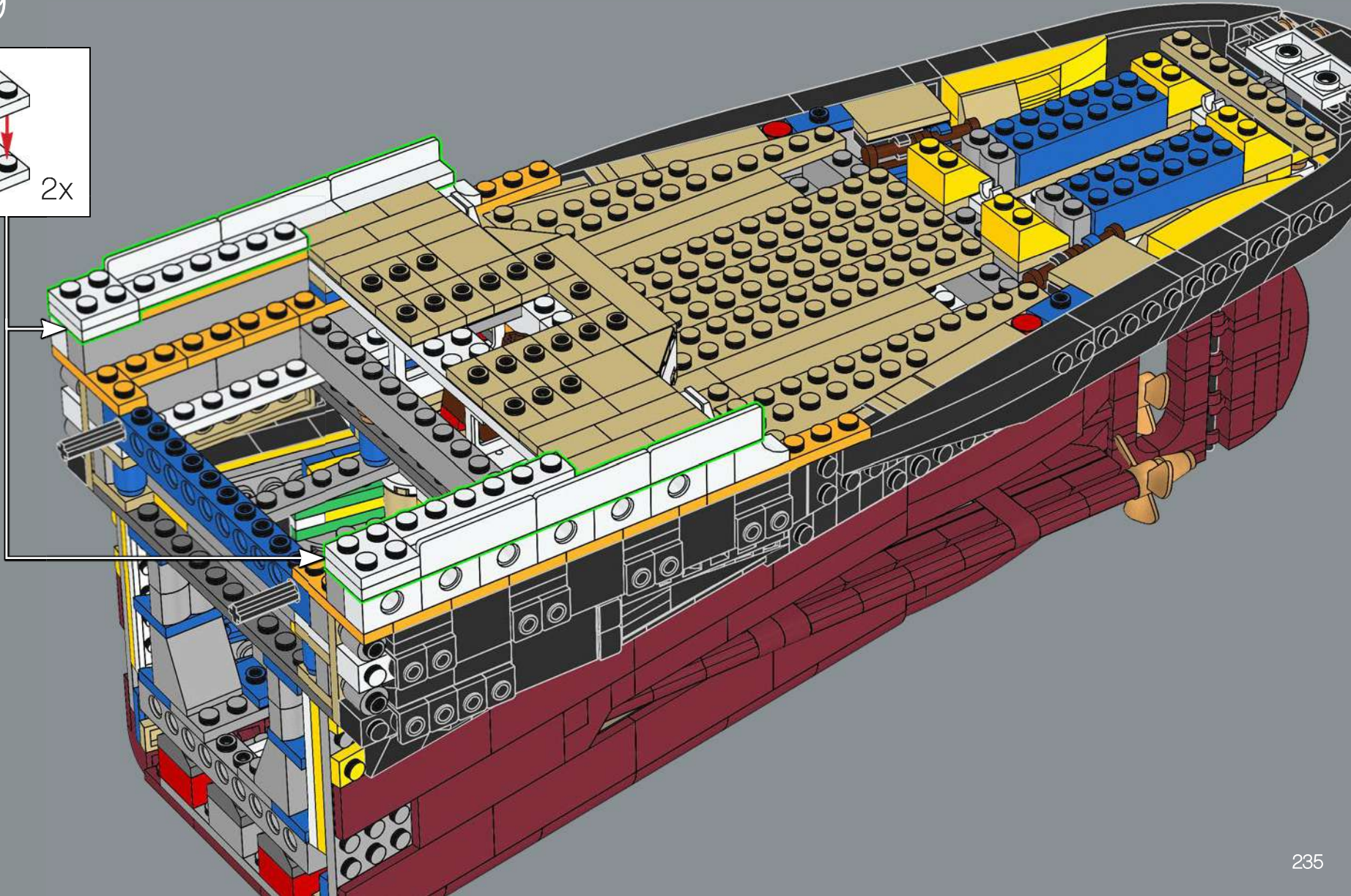
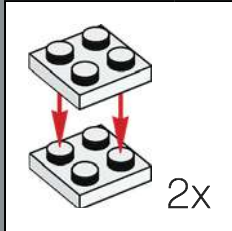

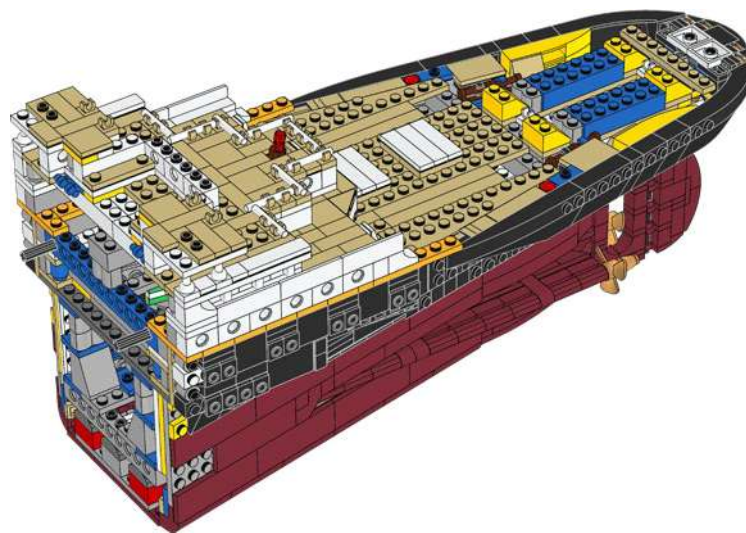
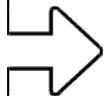

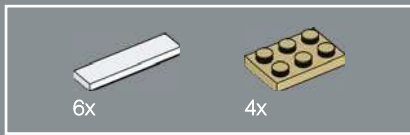

330

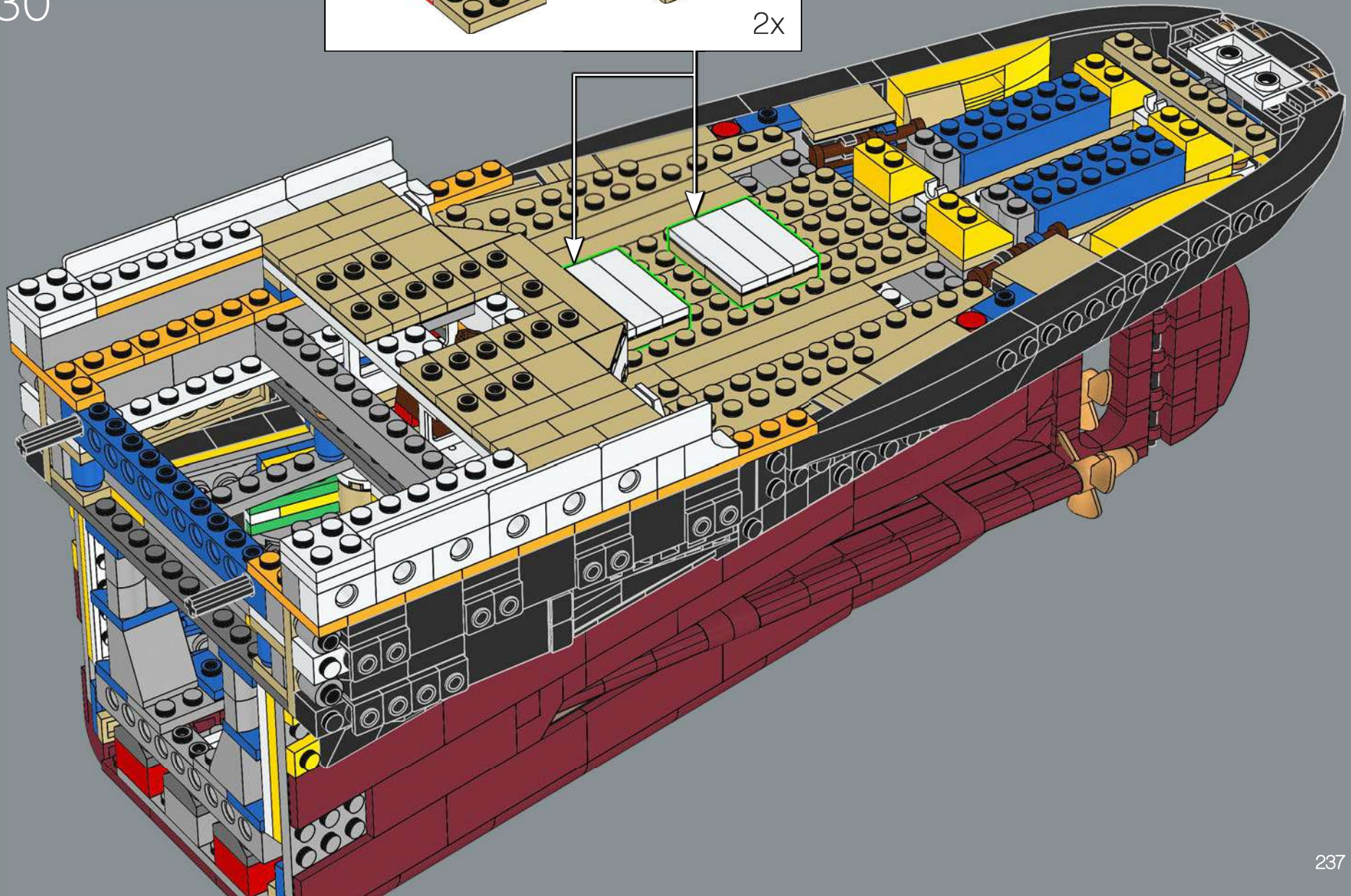
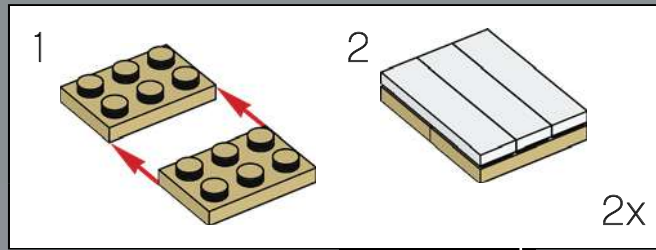

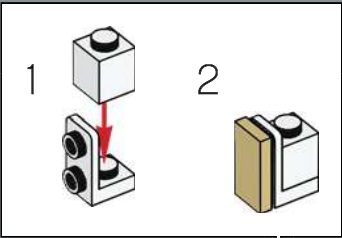
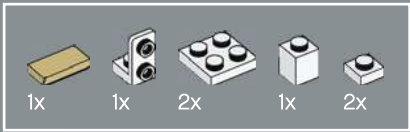

331

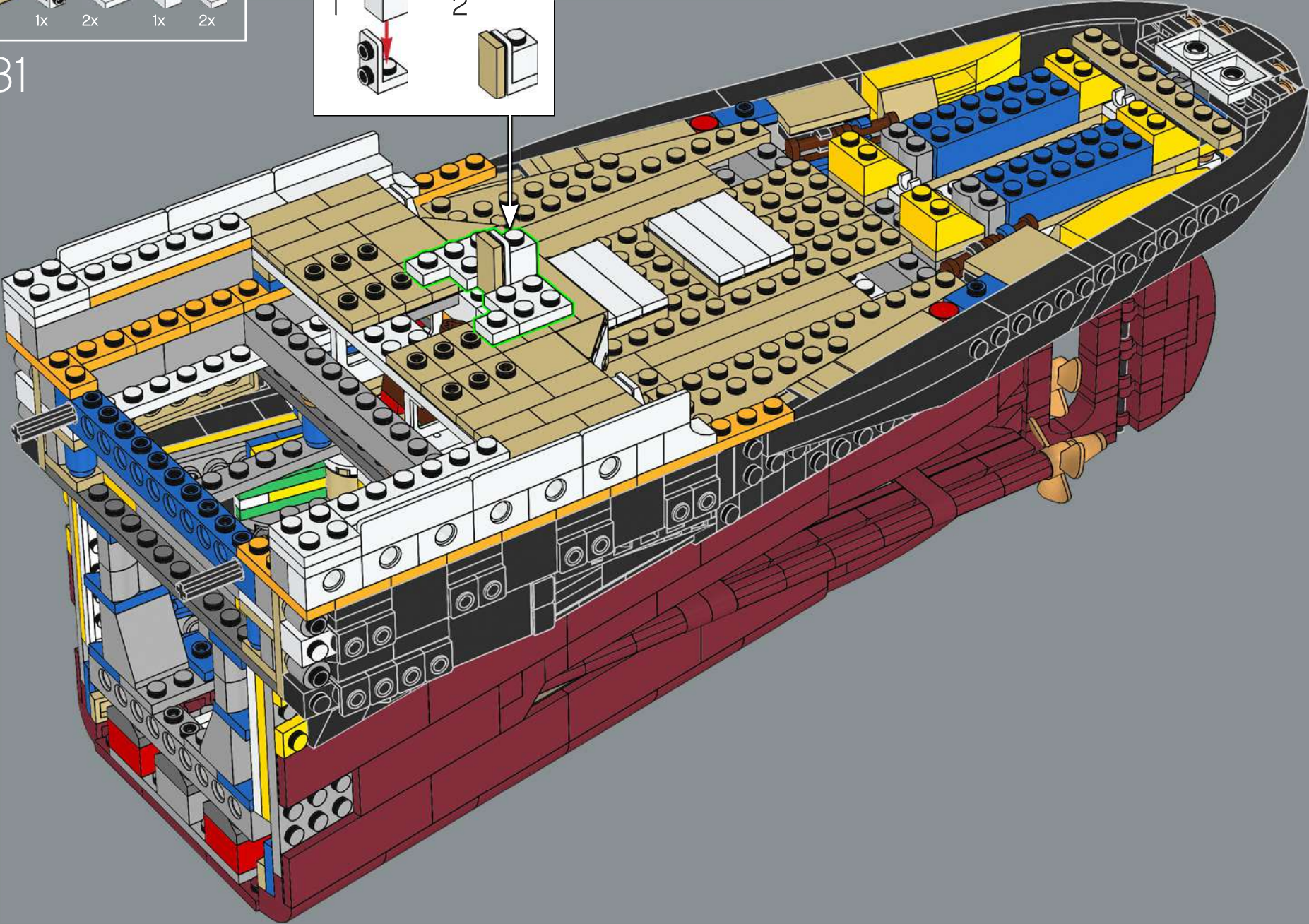

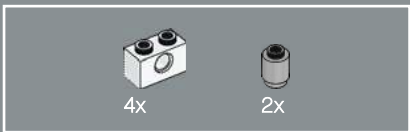

332

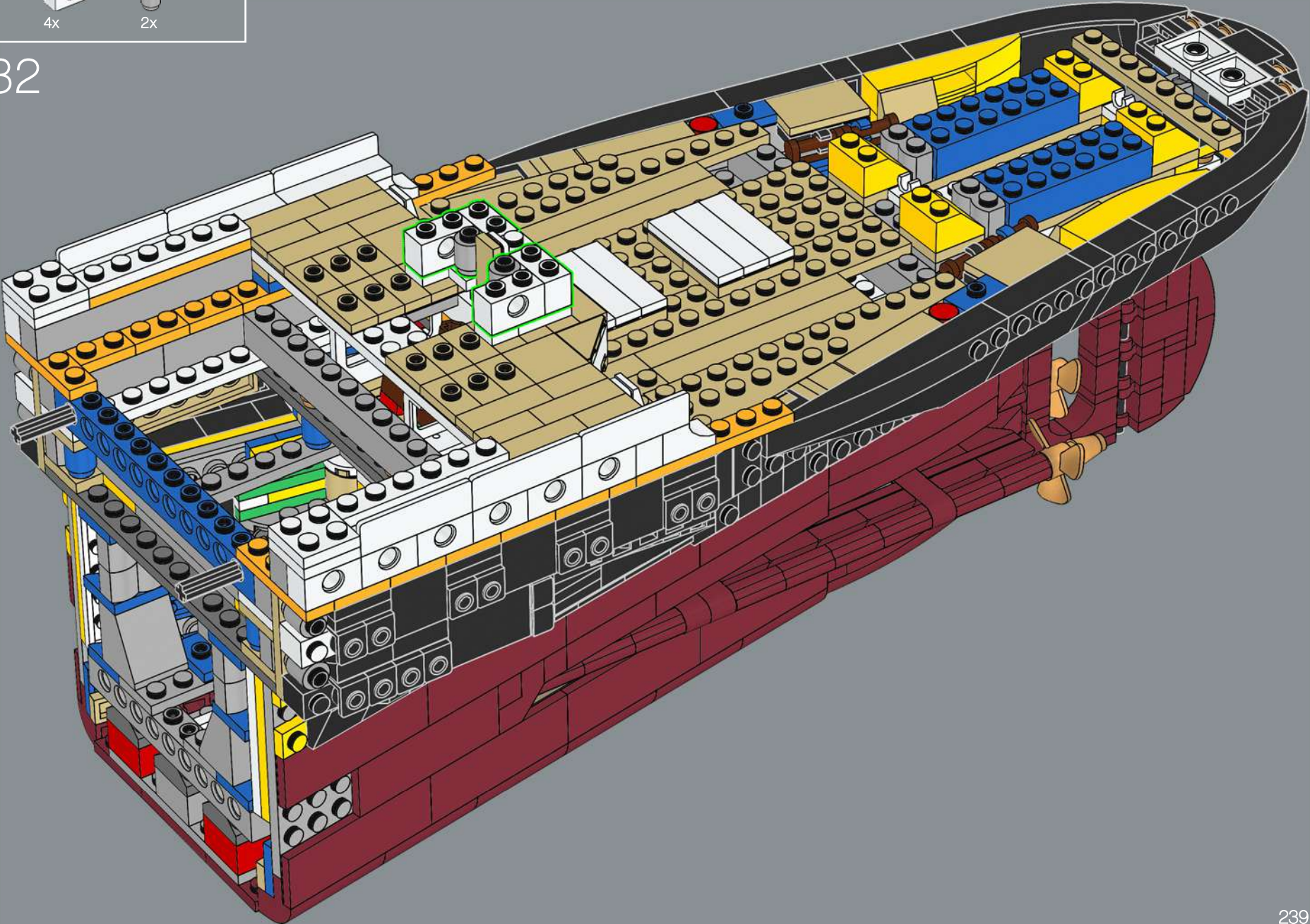



333

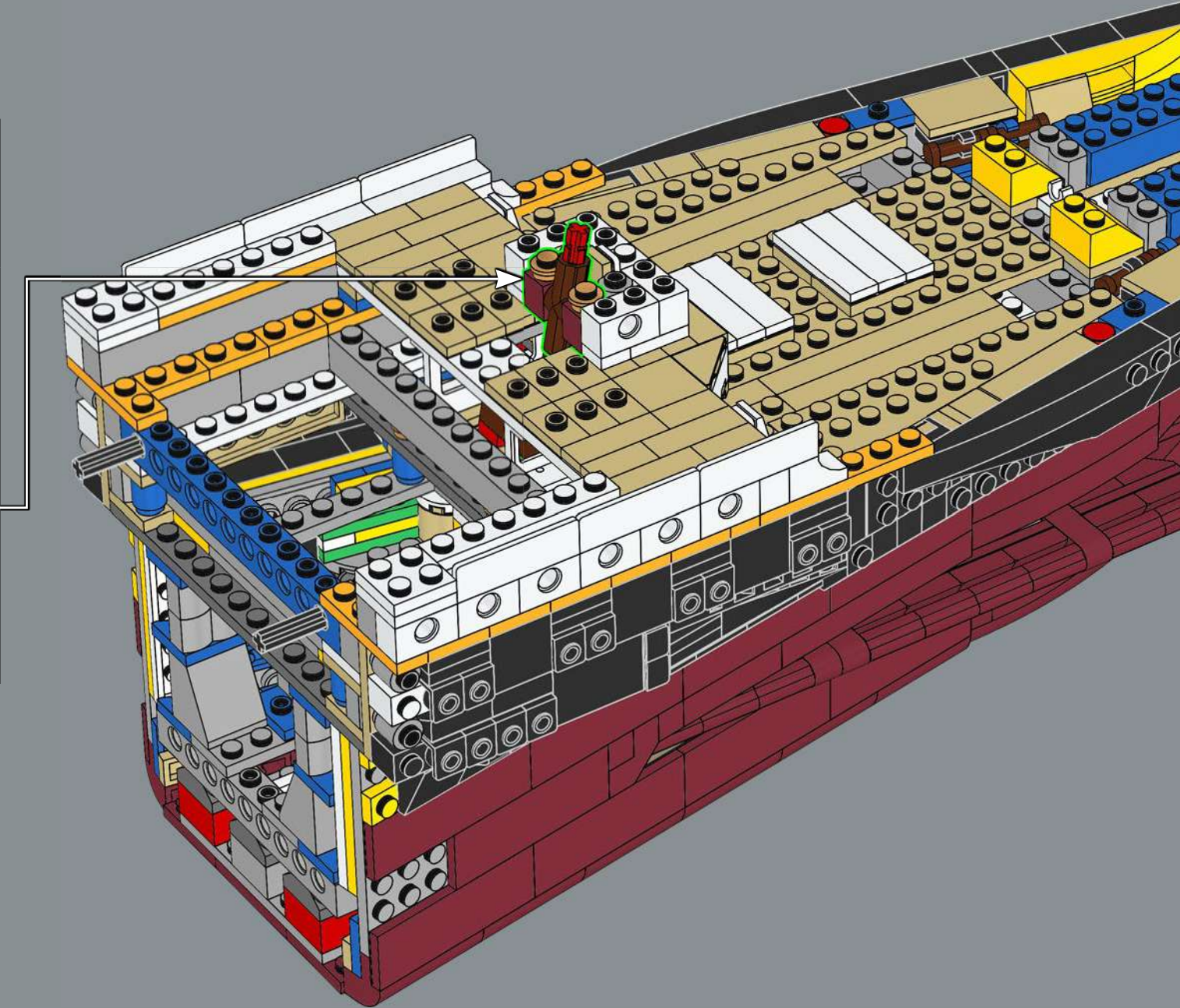
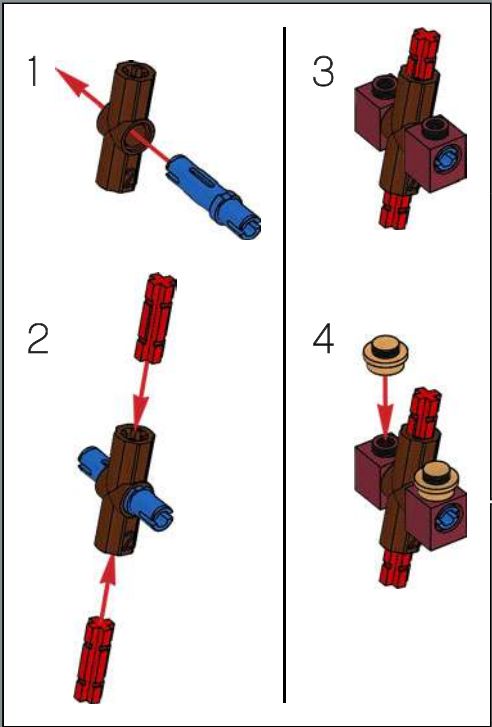

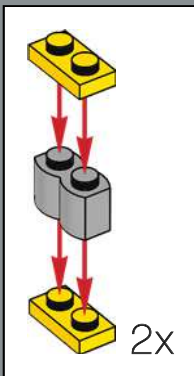
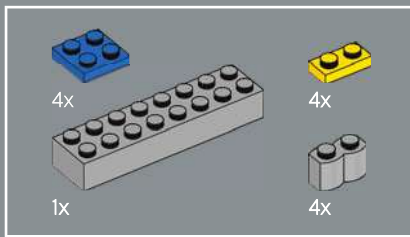

334

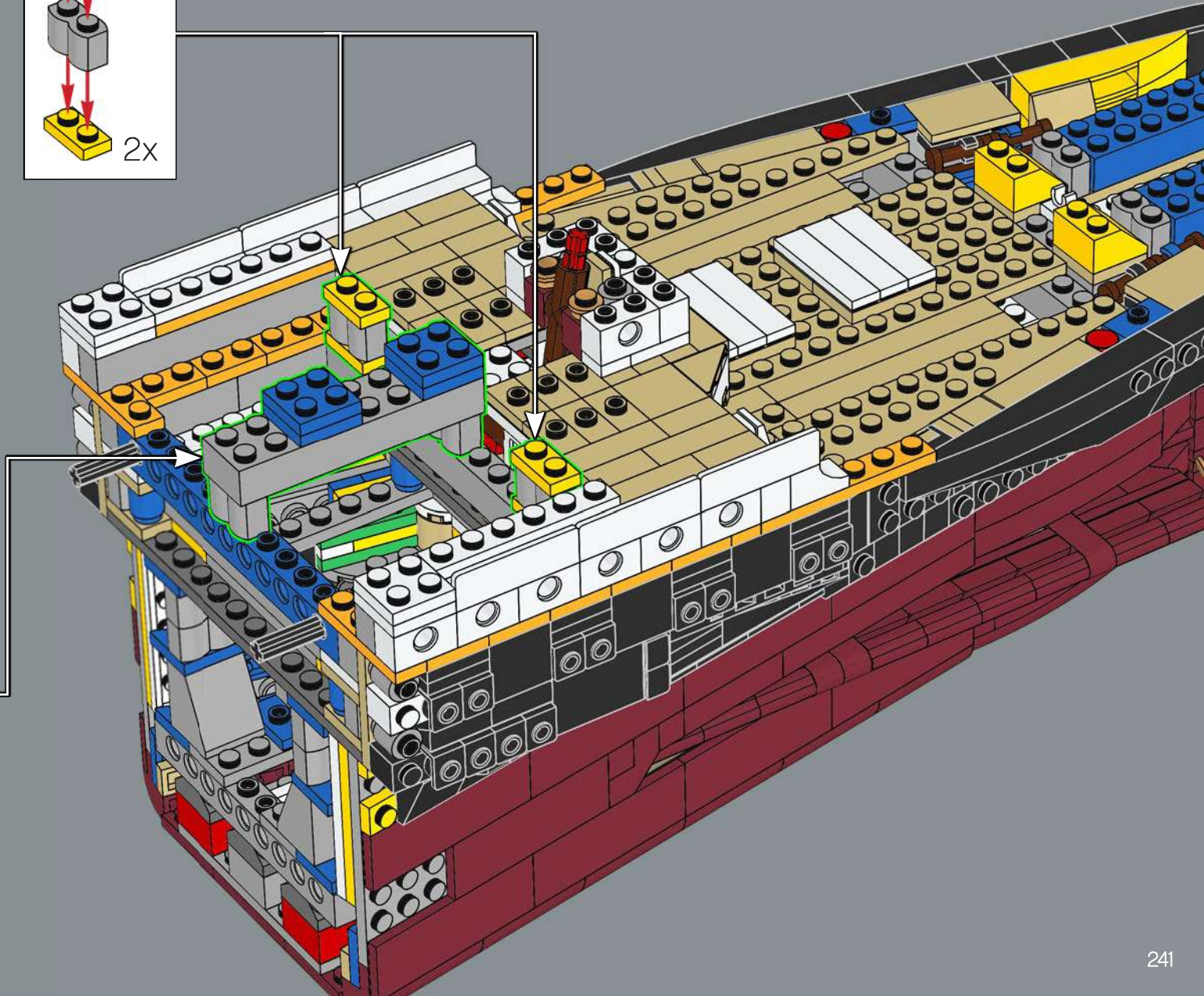
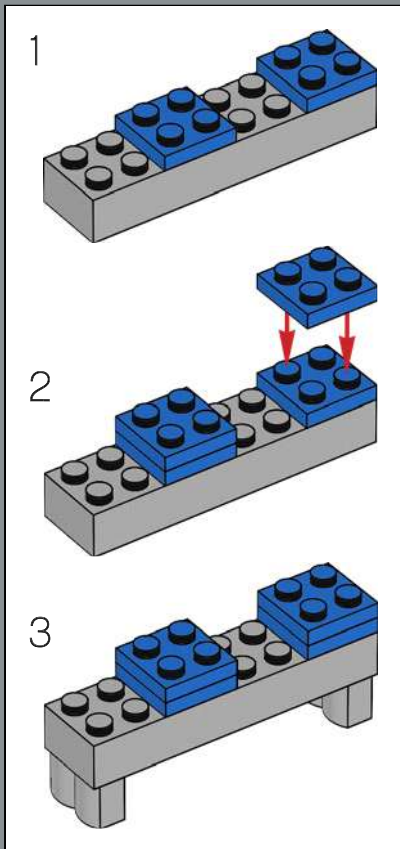

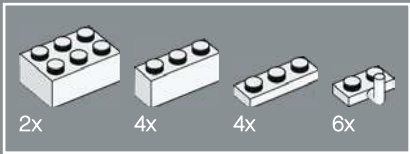

335

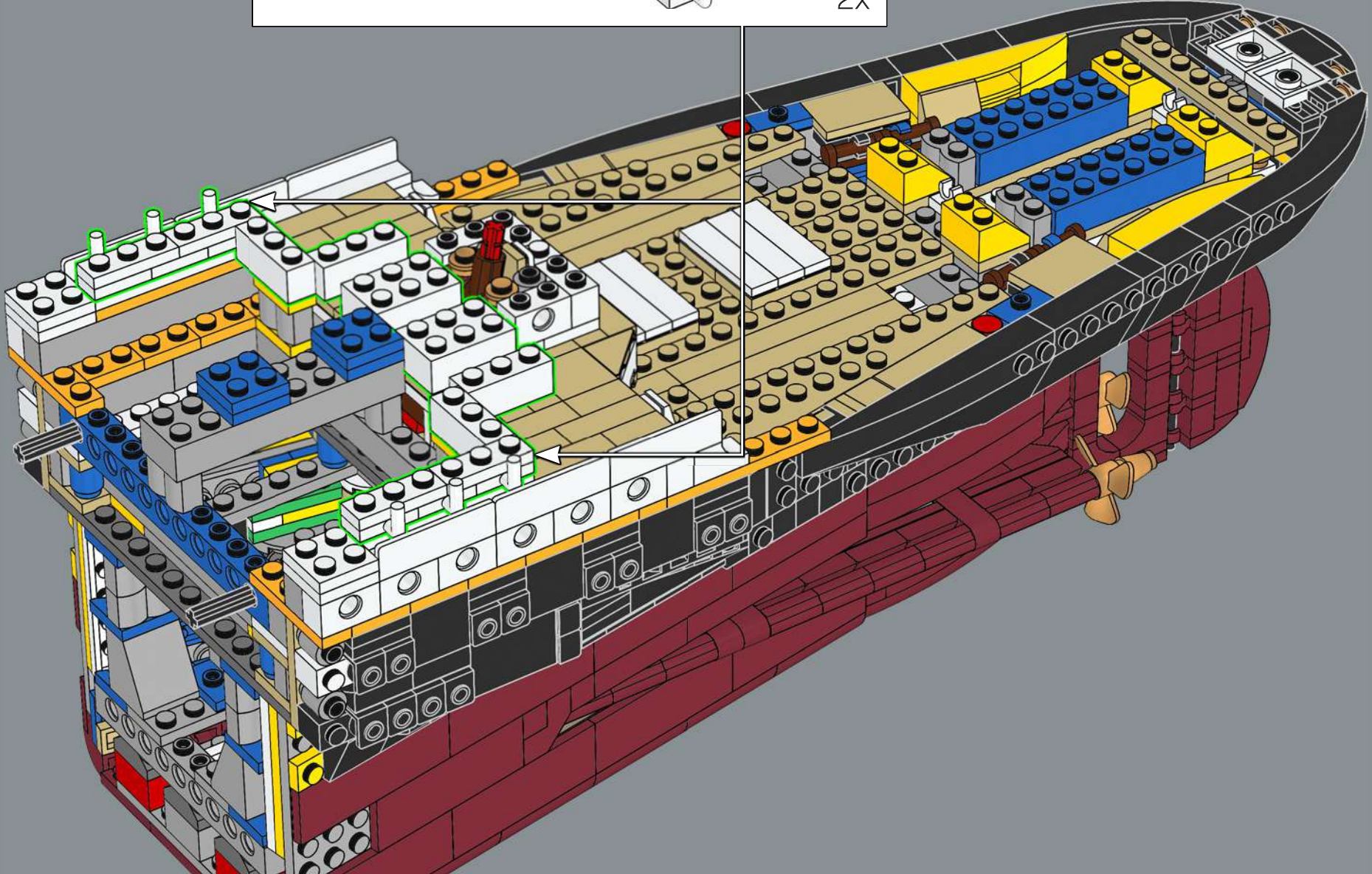
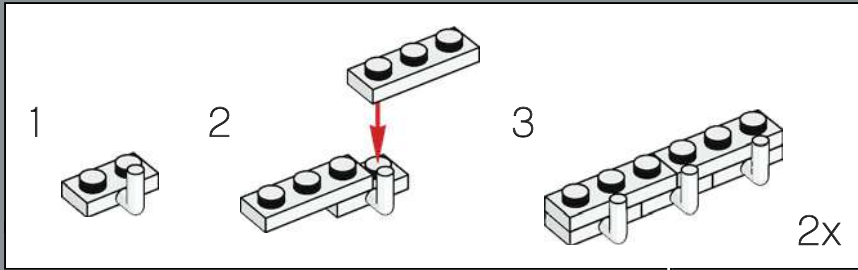

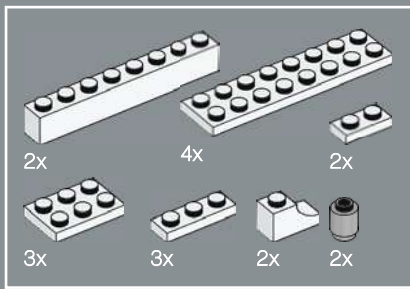

336

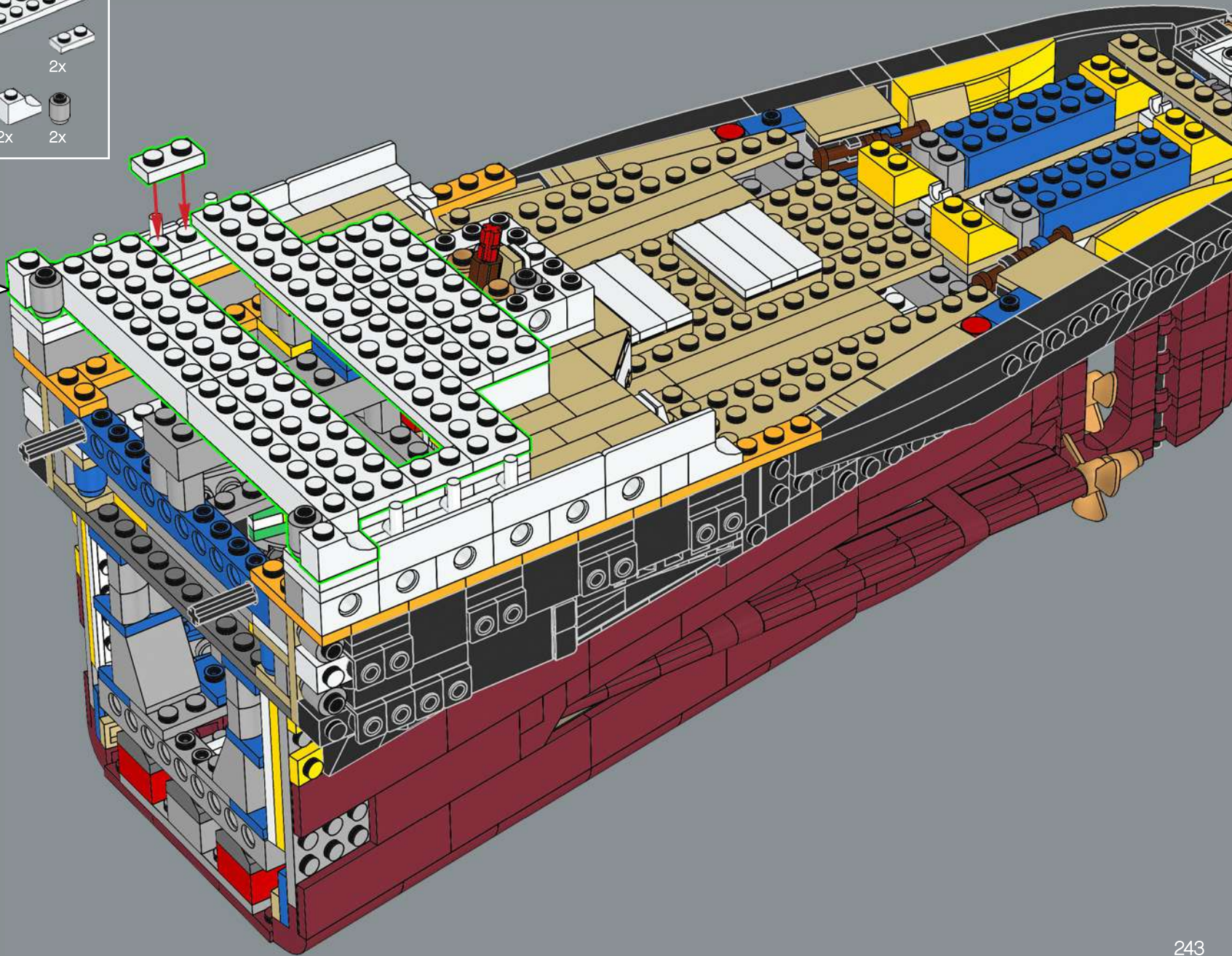
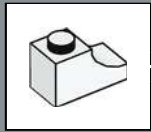

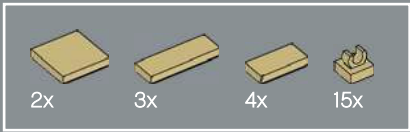

337

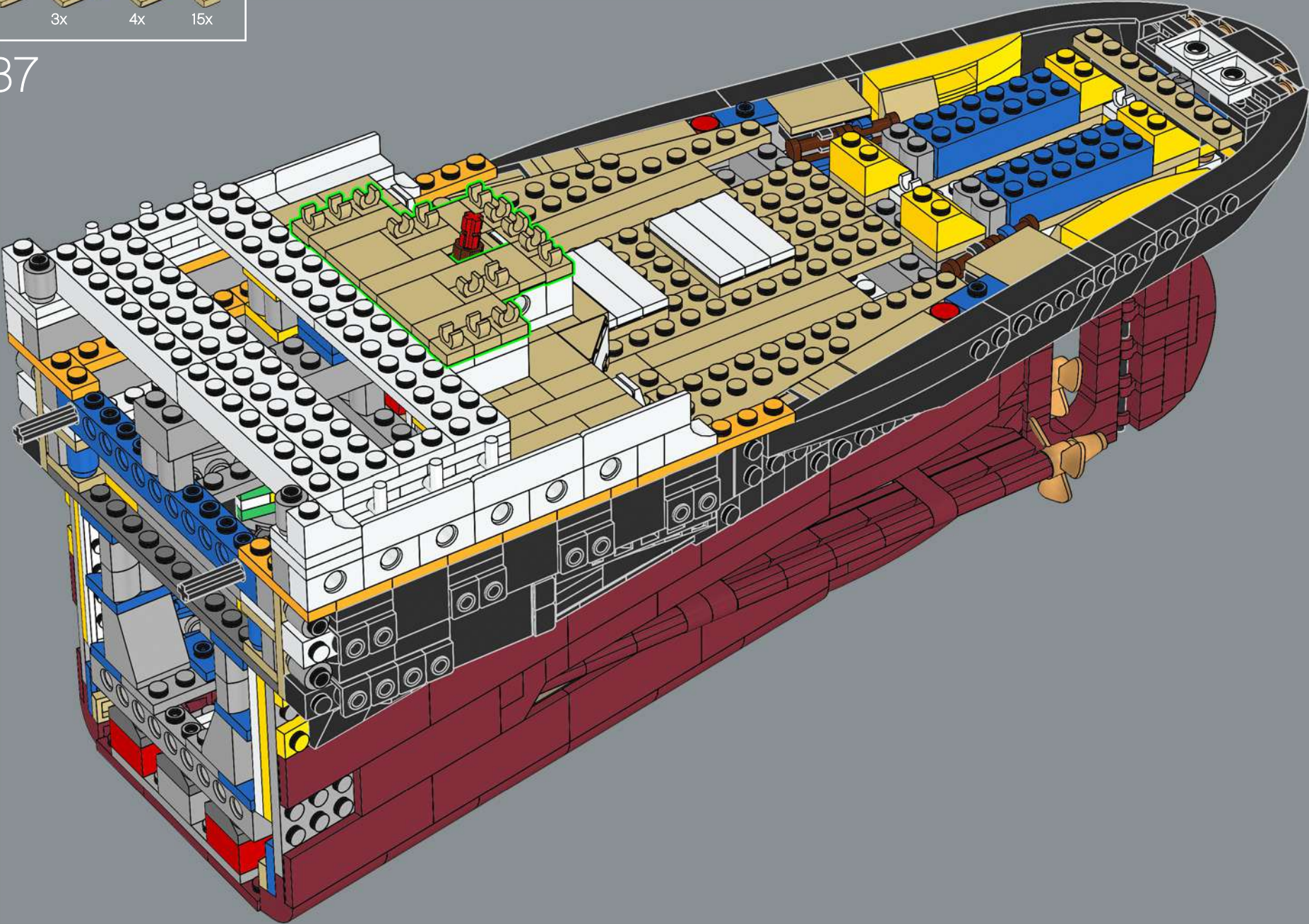

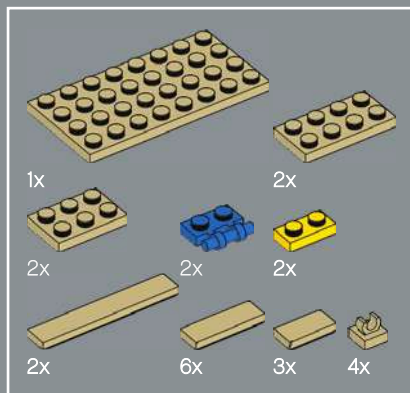

338

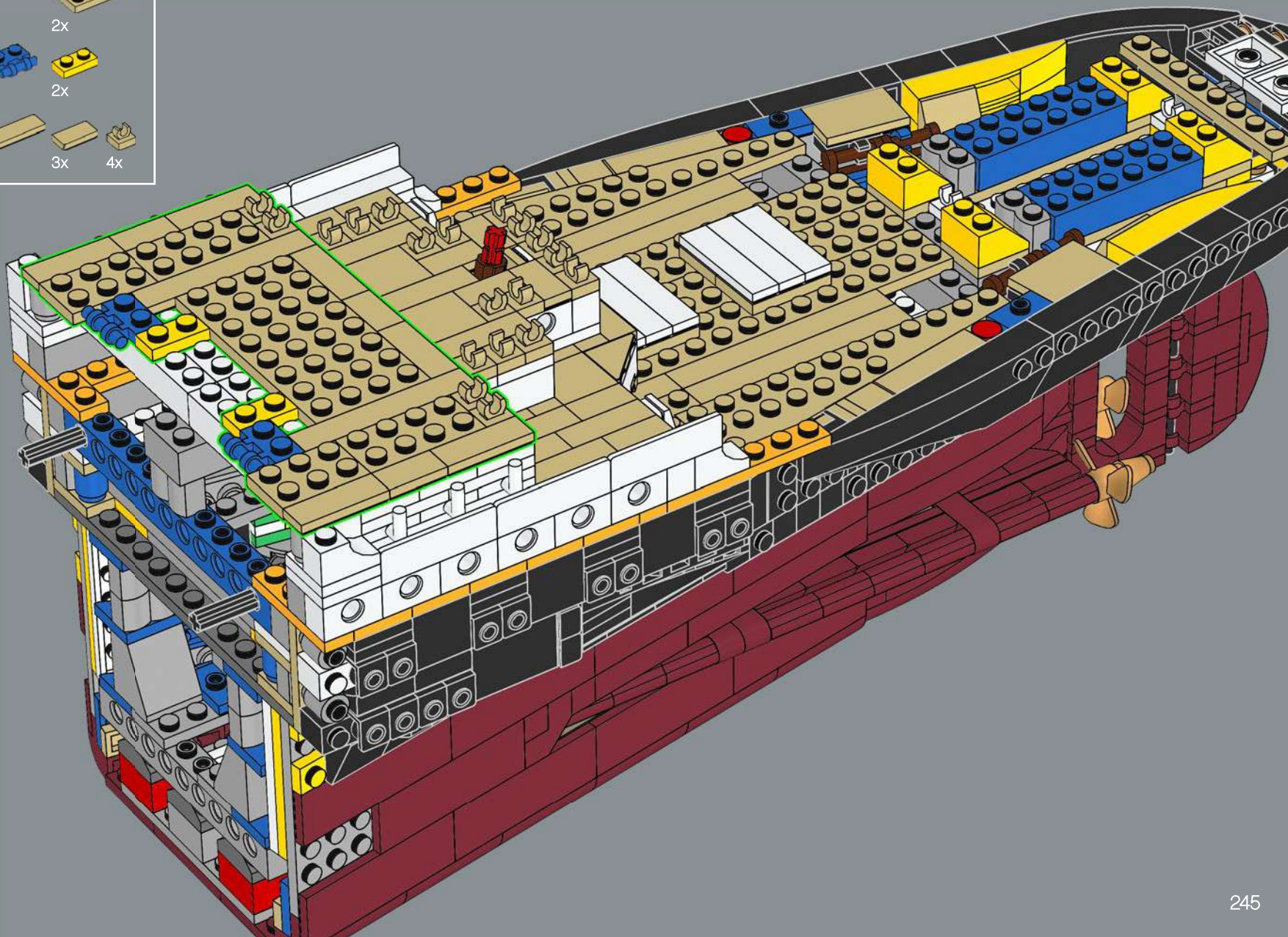

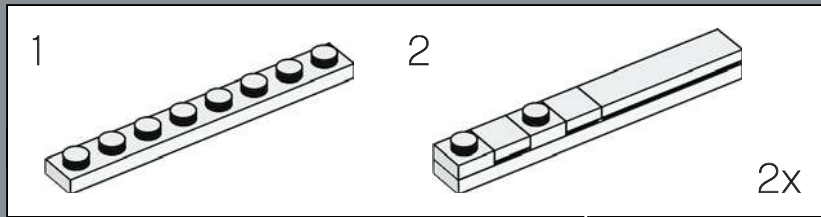
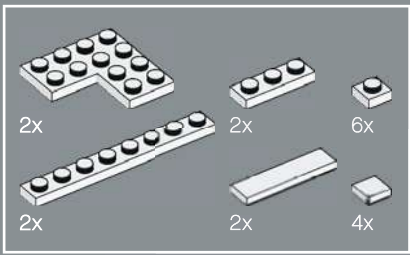

339

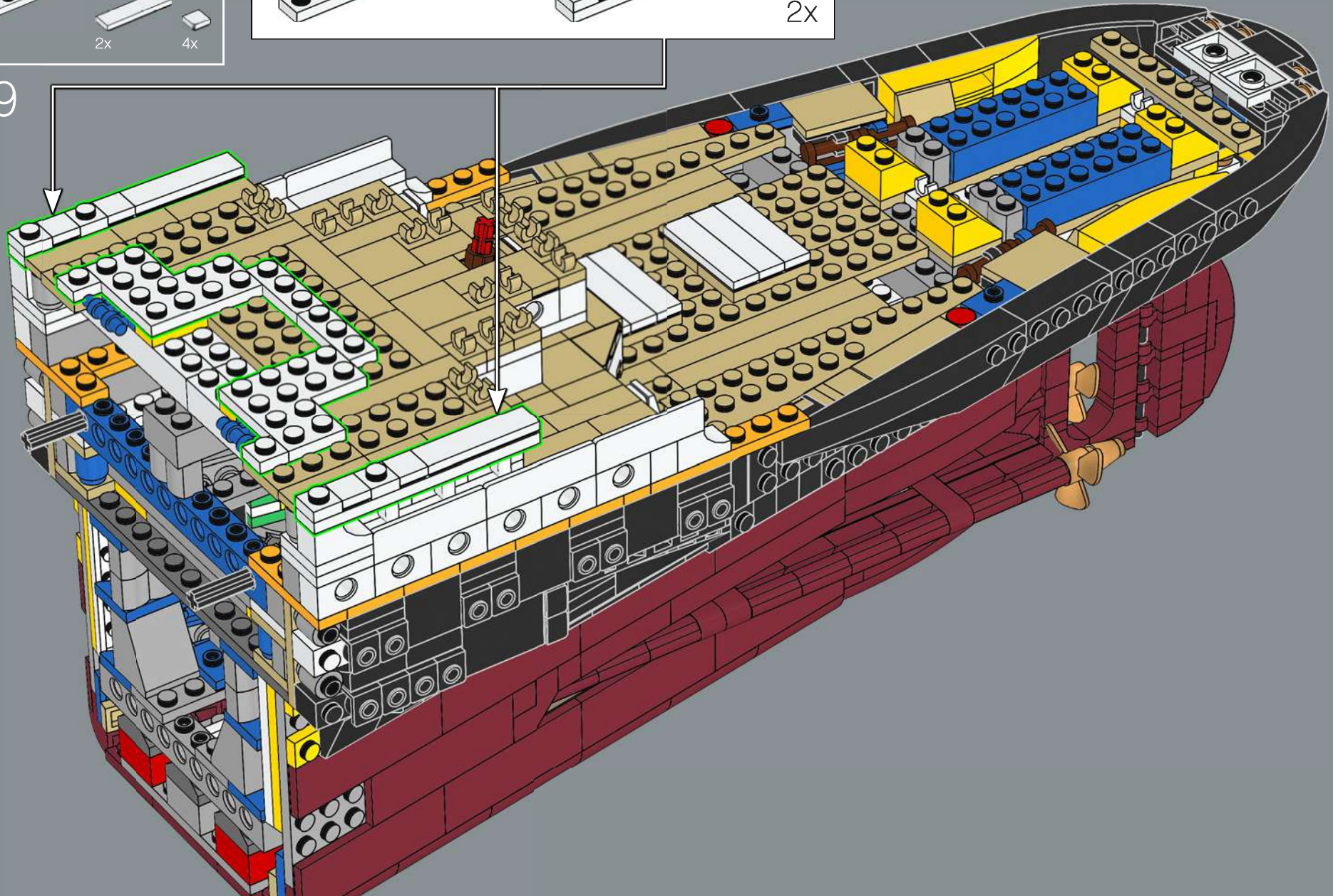

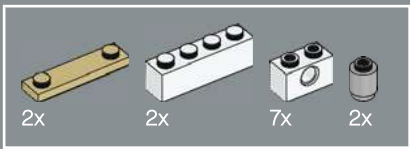

341

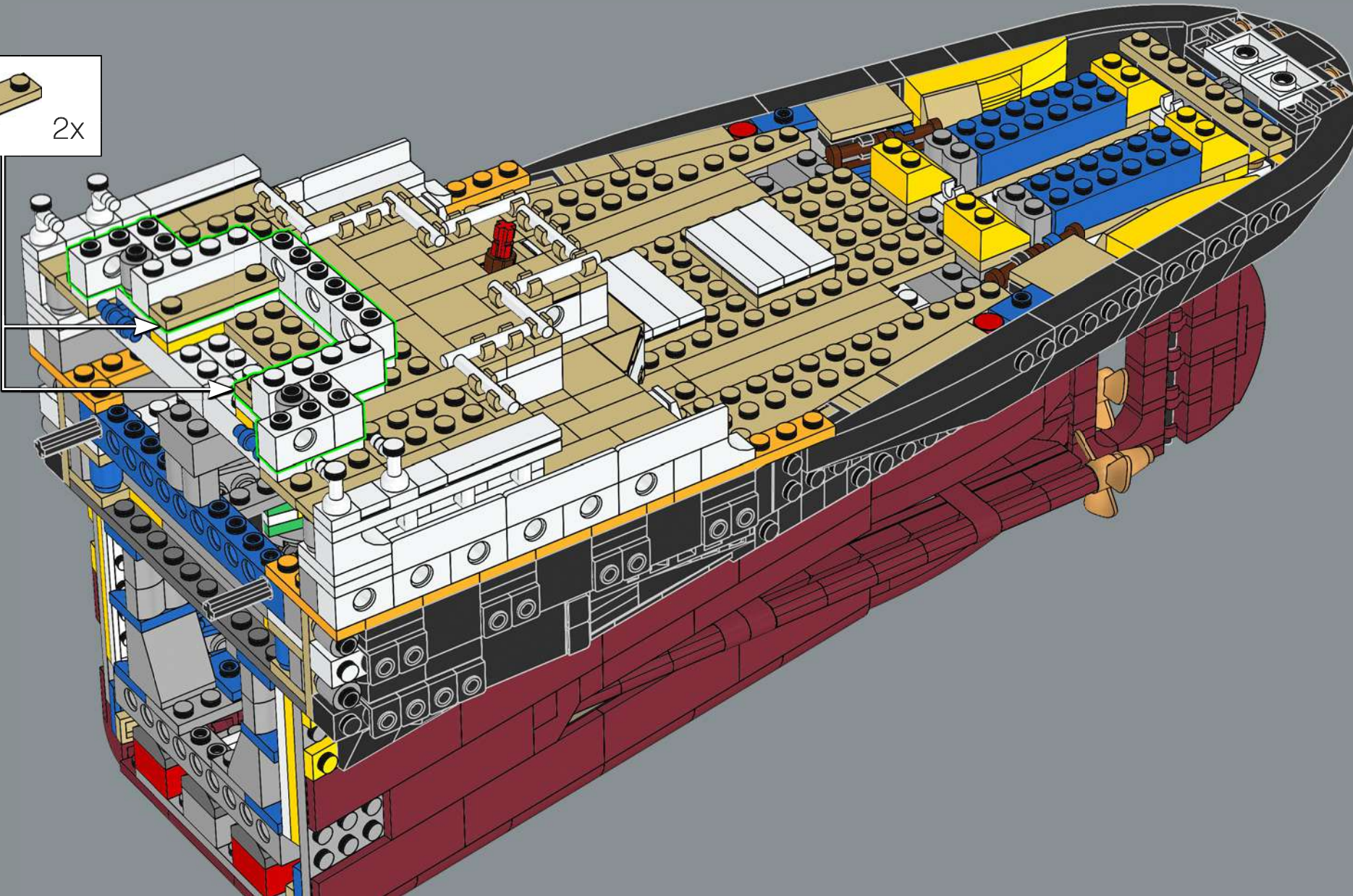
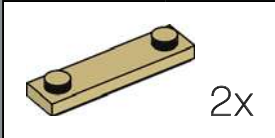

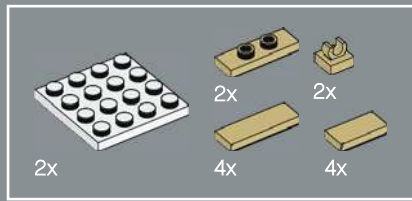

342

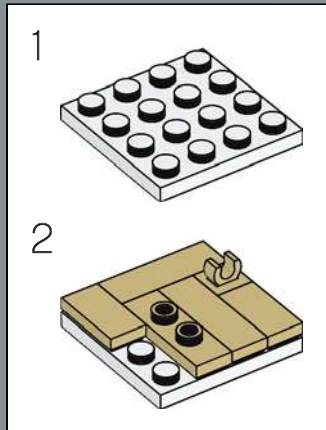
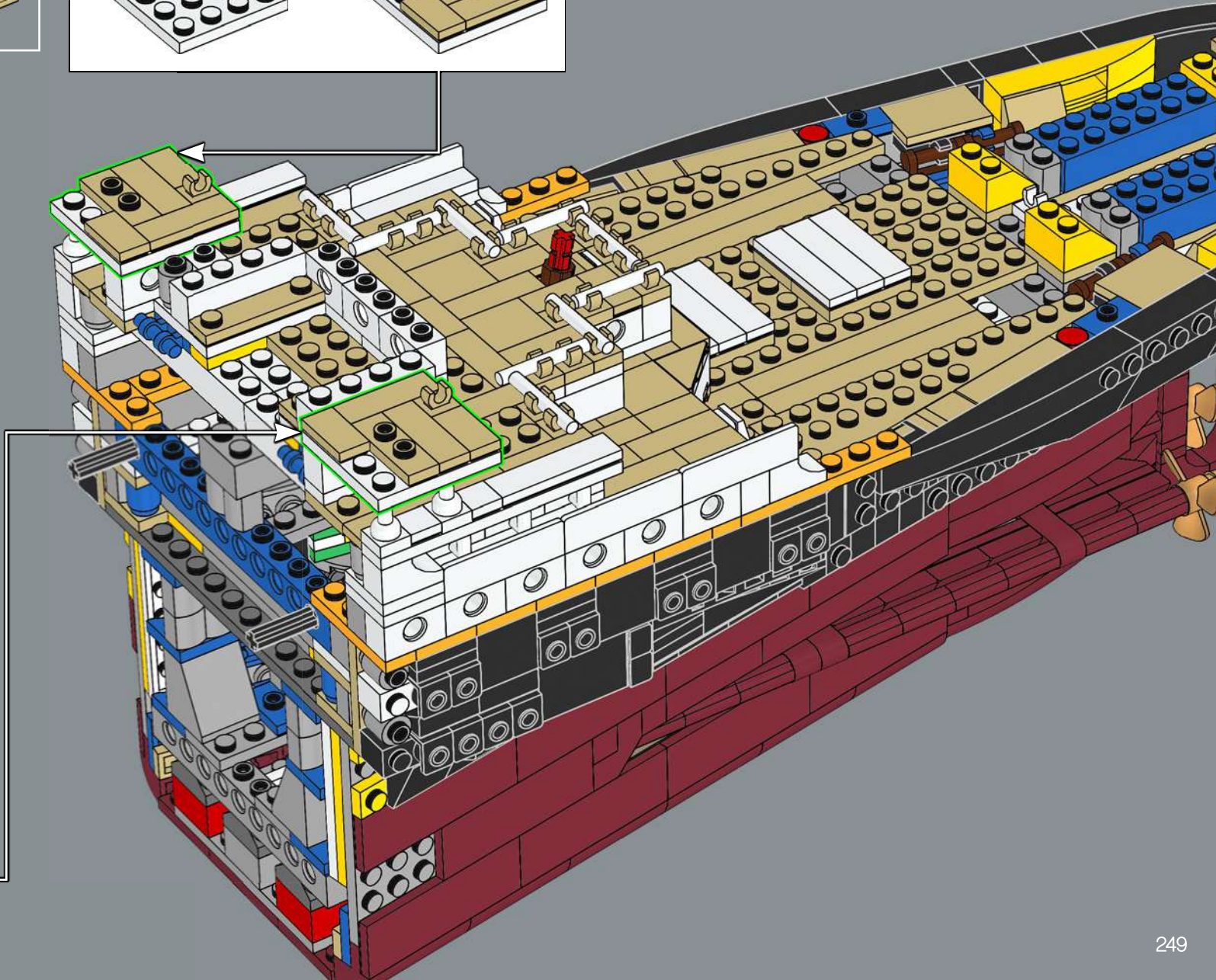
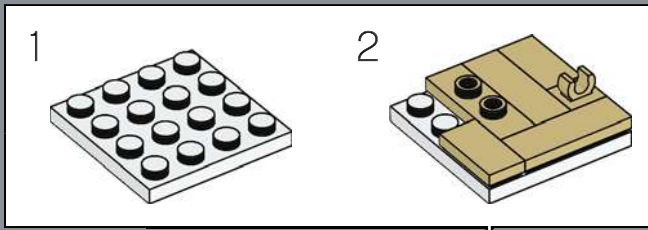

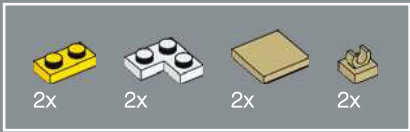

343

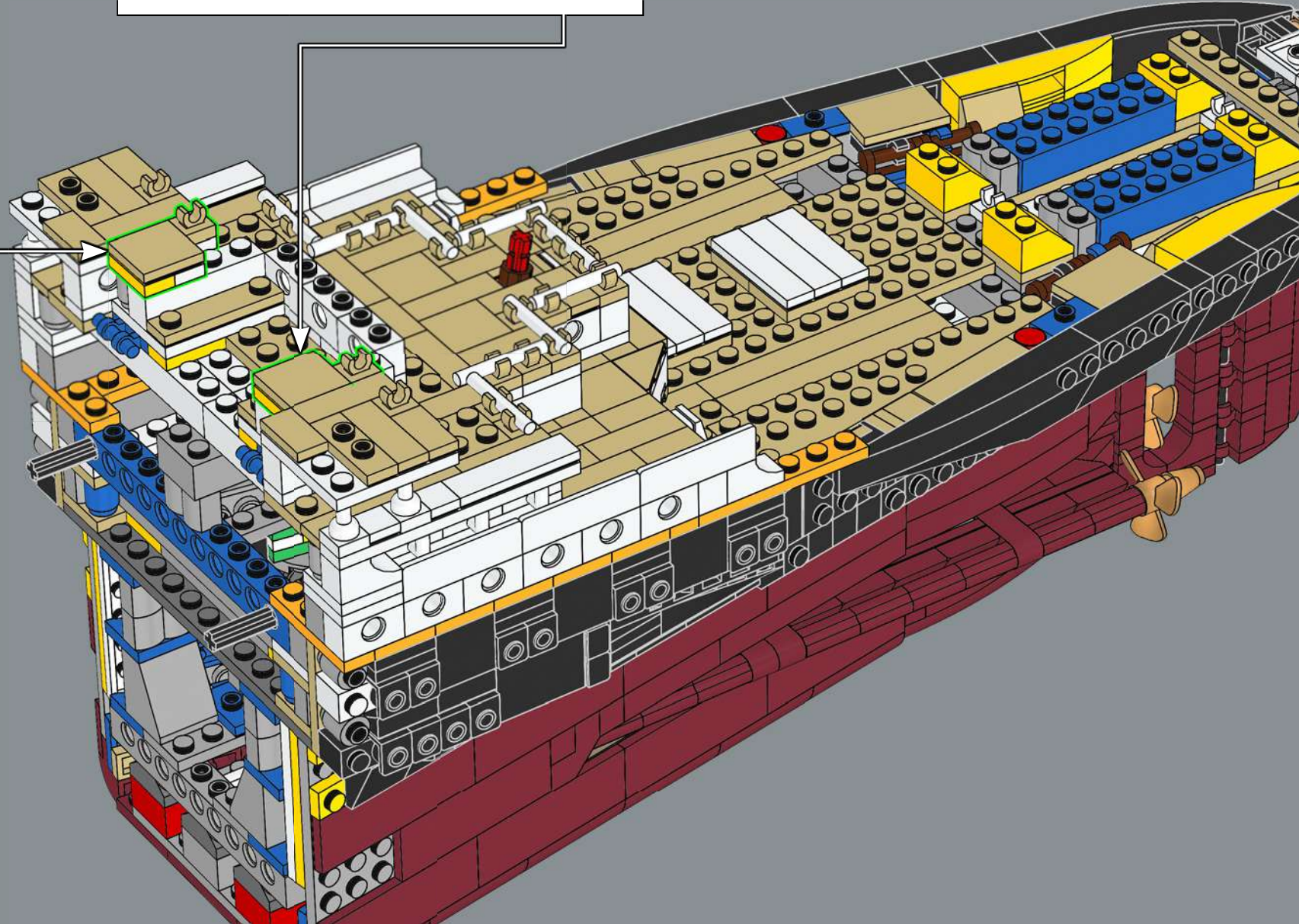
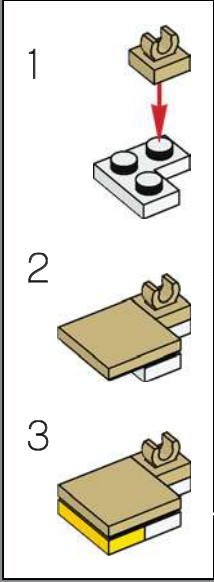
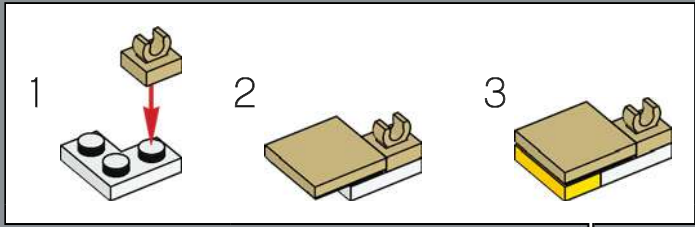

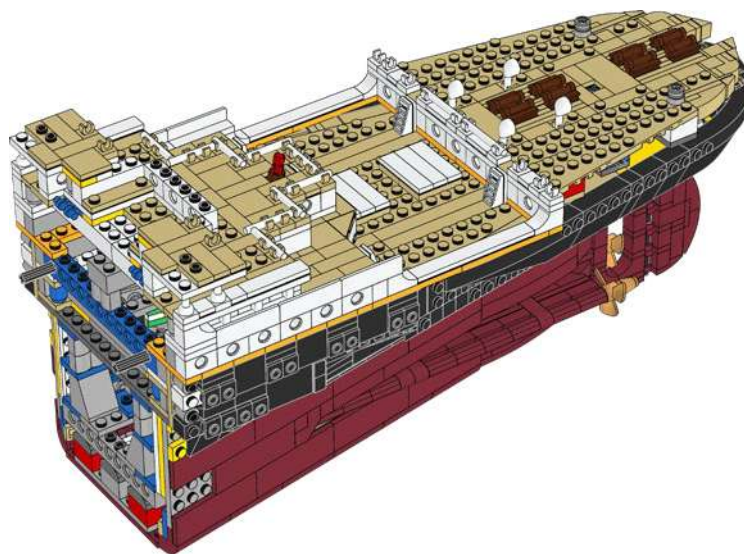

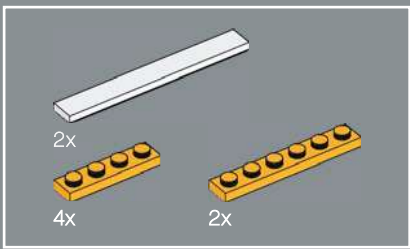

344

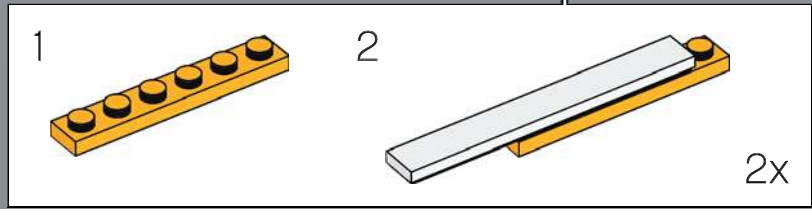
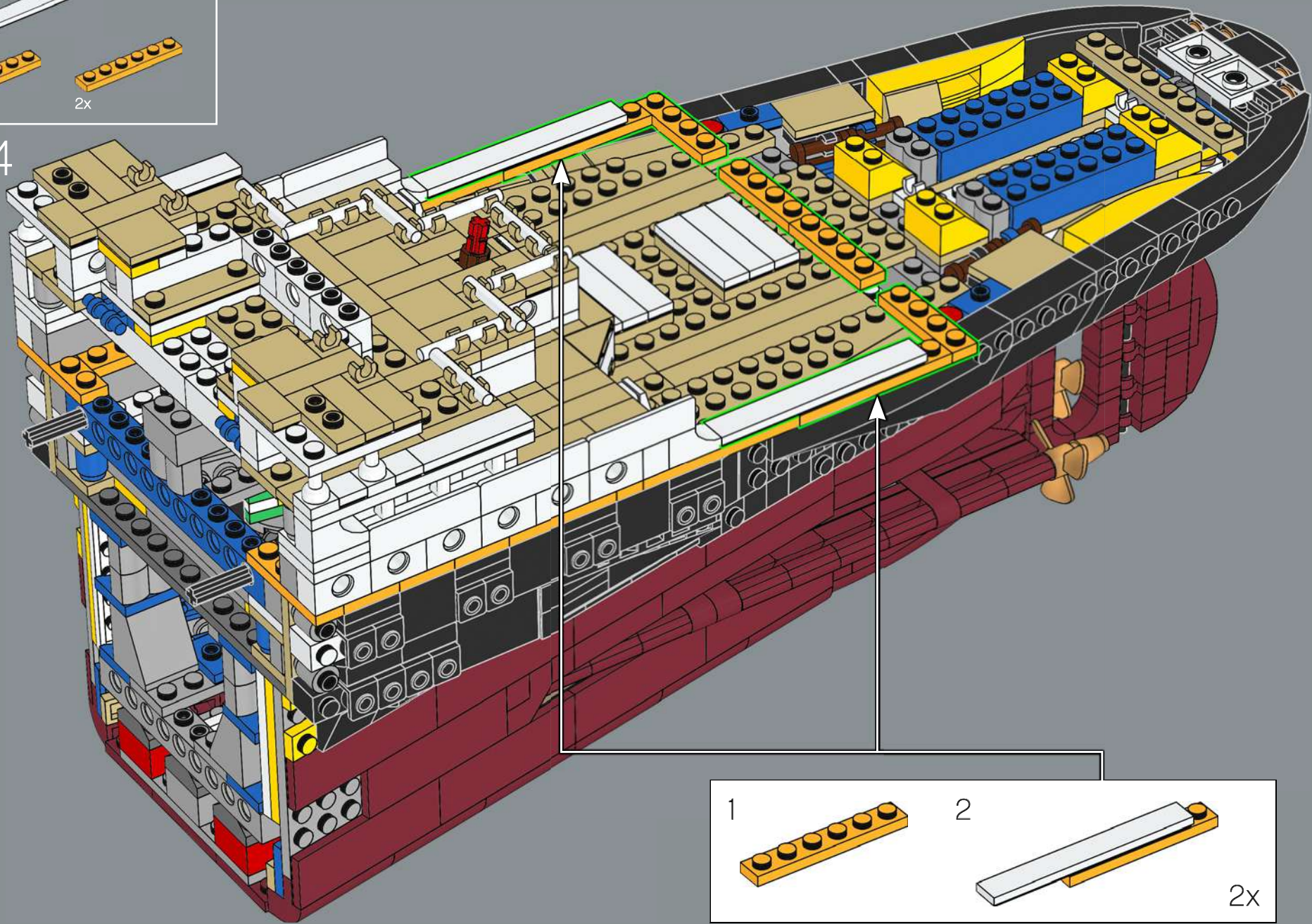

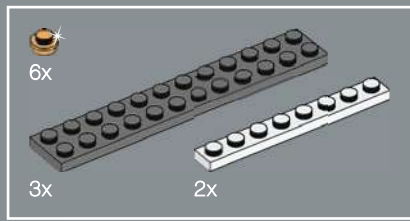

345

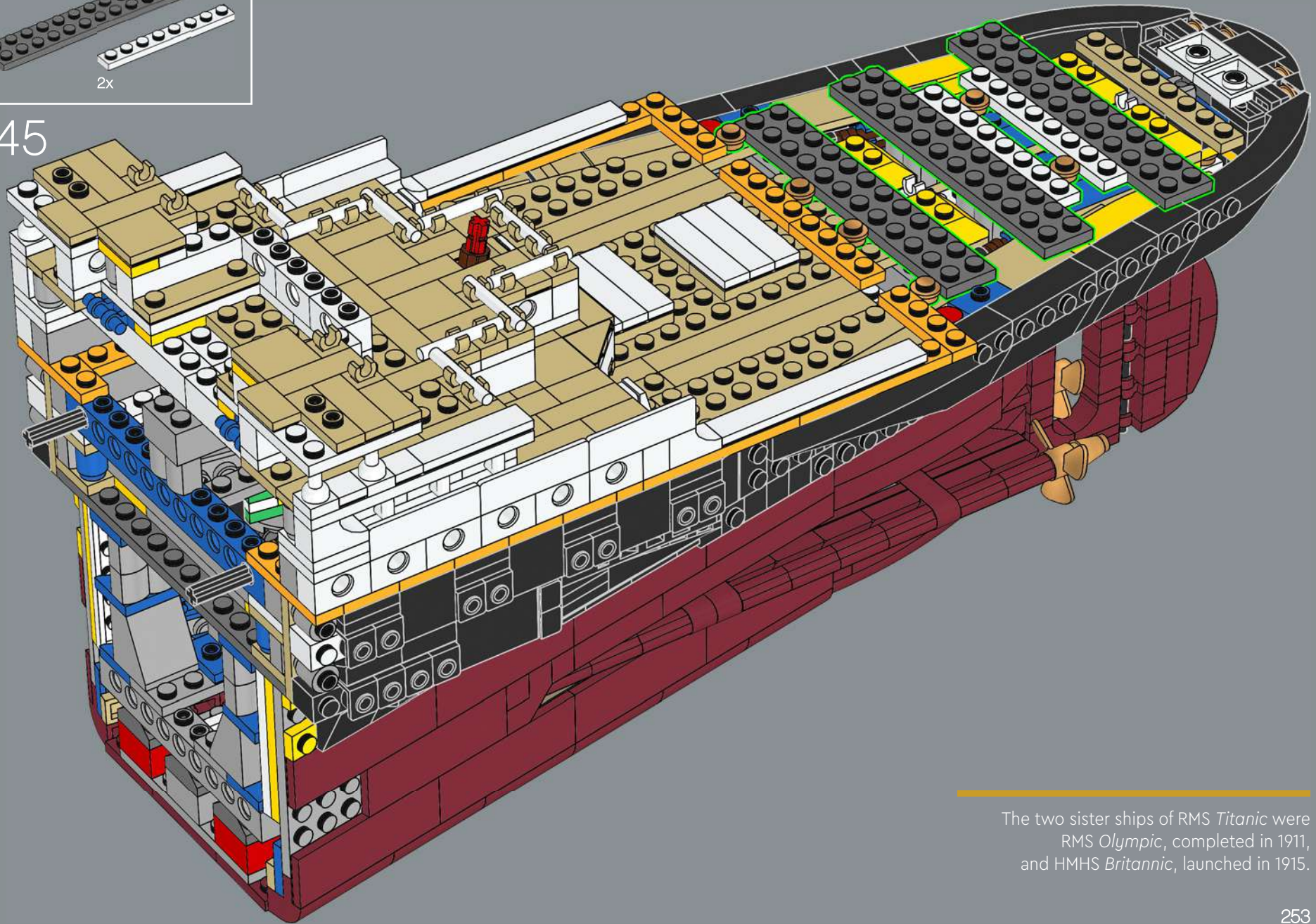

The two sister ships of RMS *Titanic* were RMS *Olympic*, completed in 1911, and HMHS *Britannic*, launched in 1915.

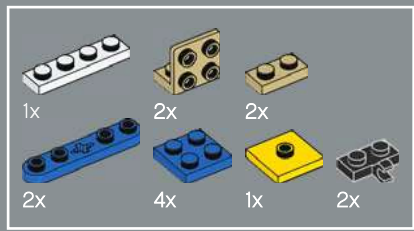

346

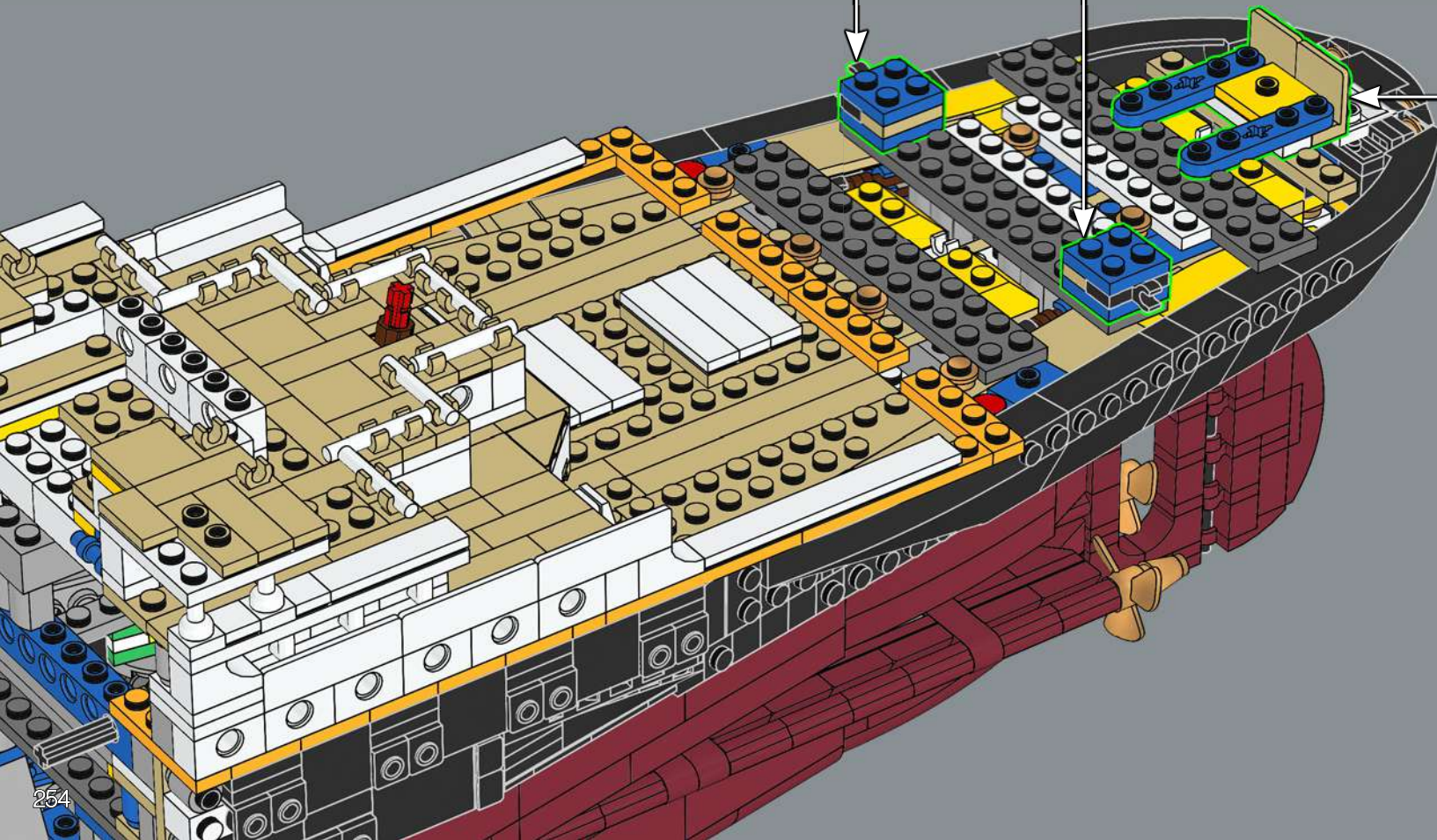
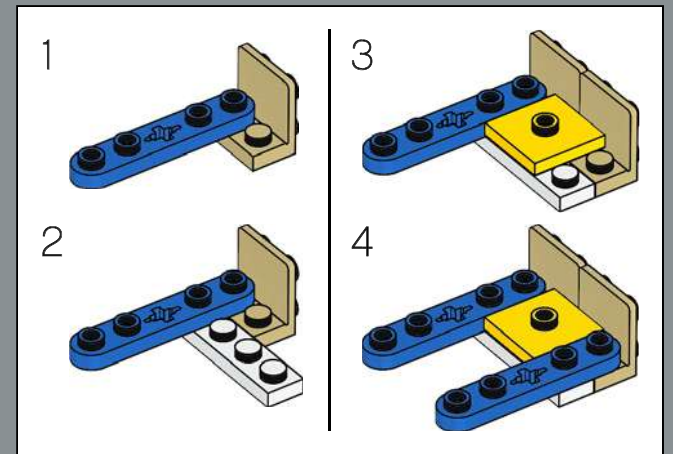
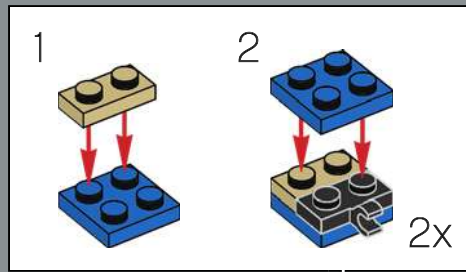

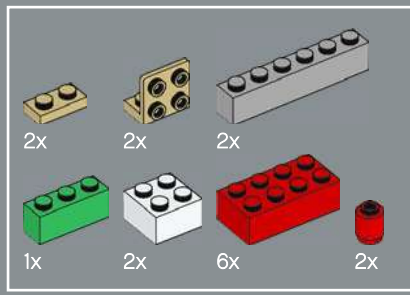

347

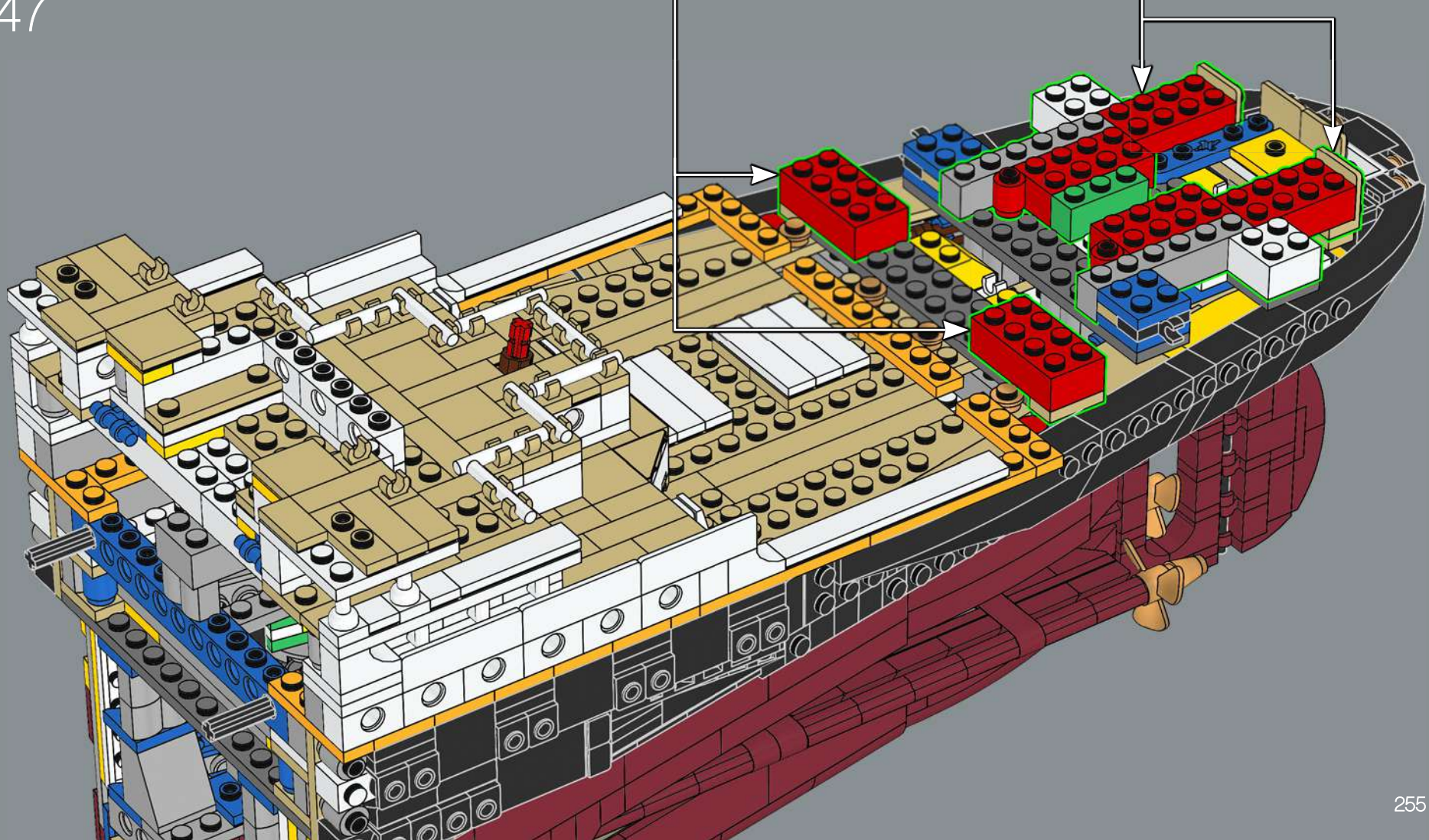
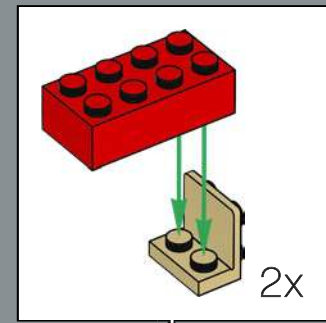
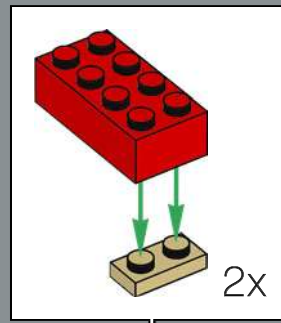

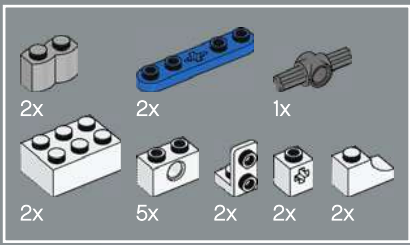

348

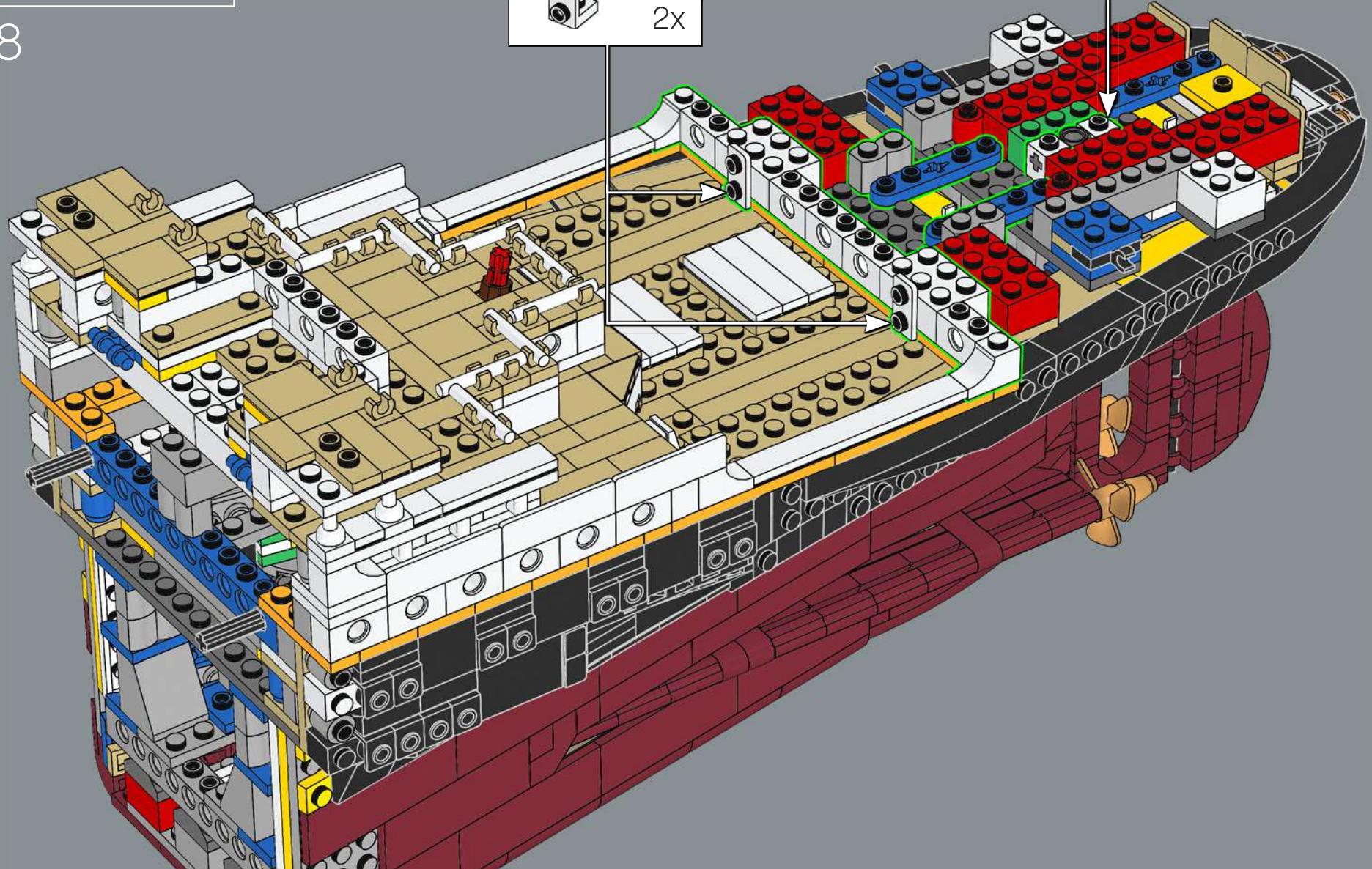
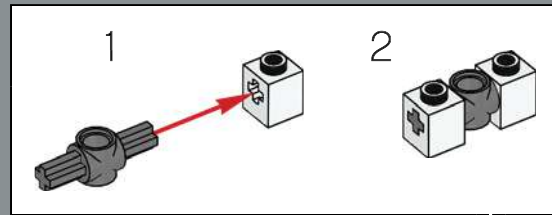
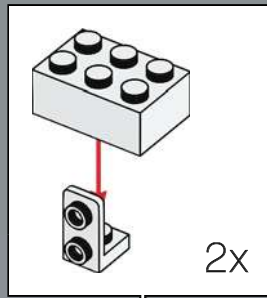

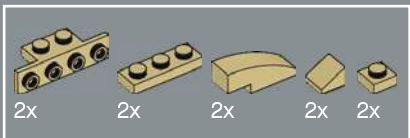

350

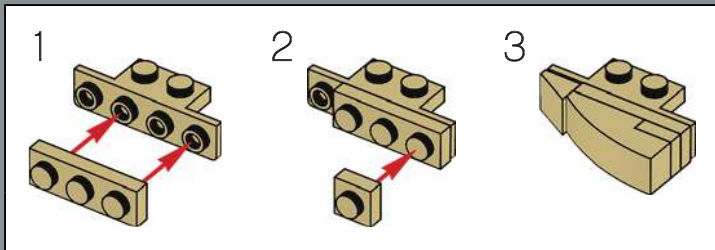

2

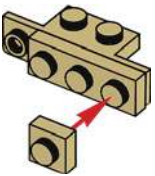

3

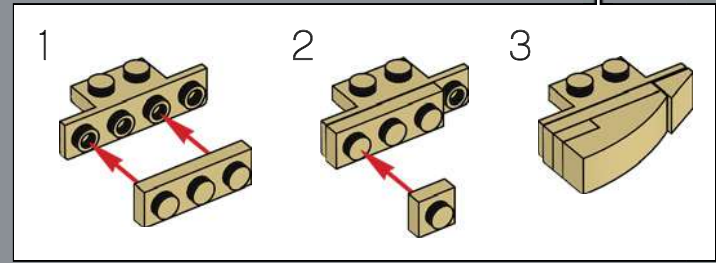
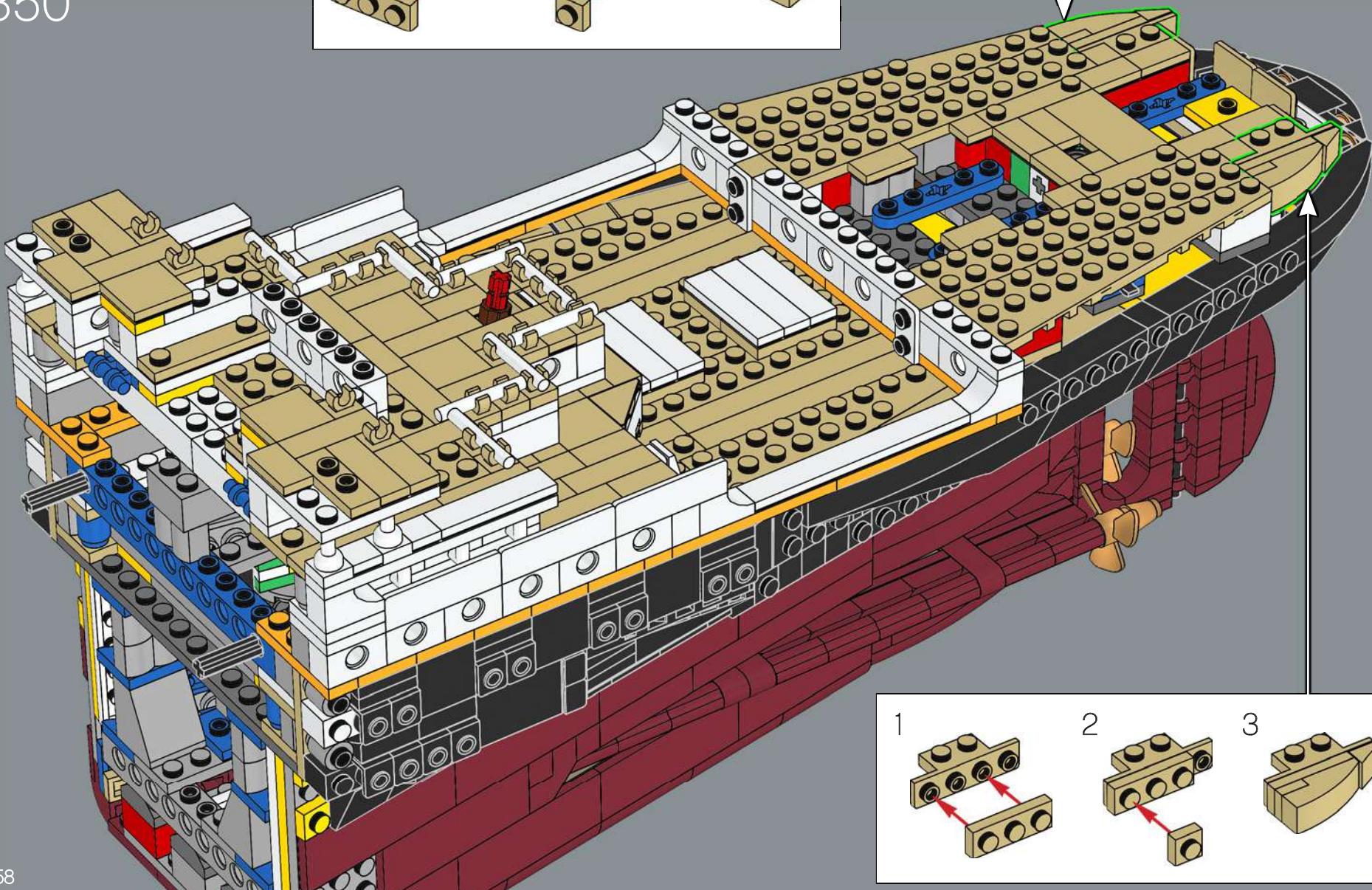
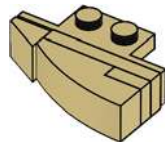

2

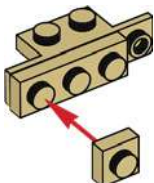

3

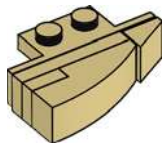

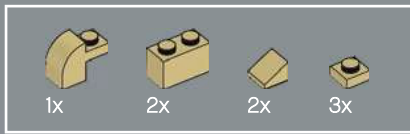

351

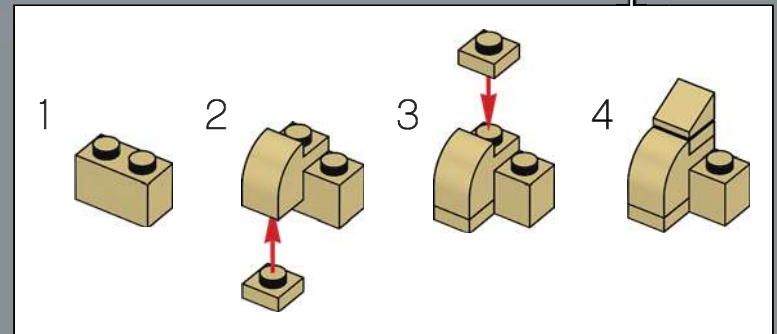
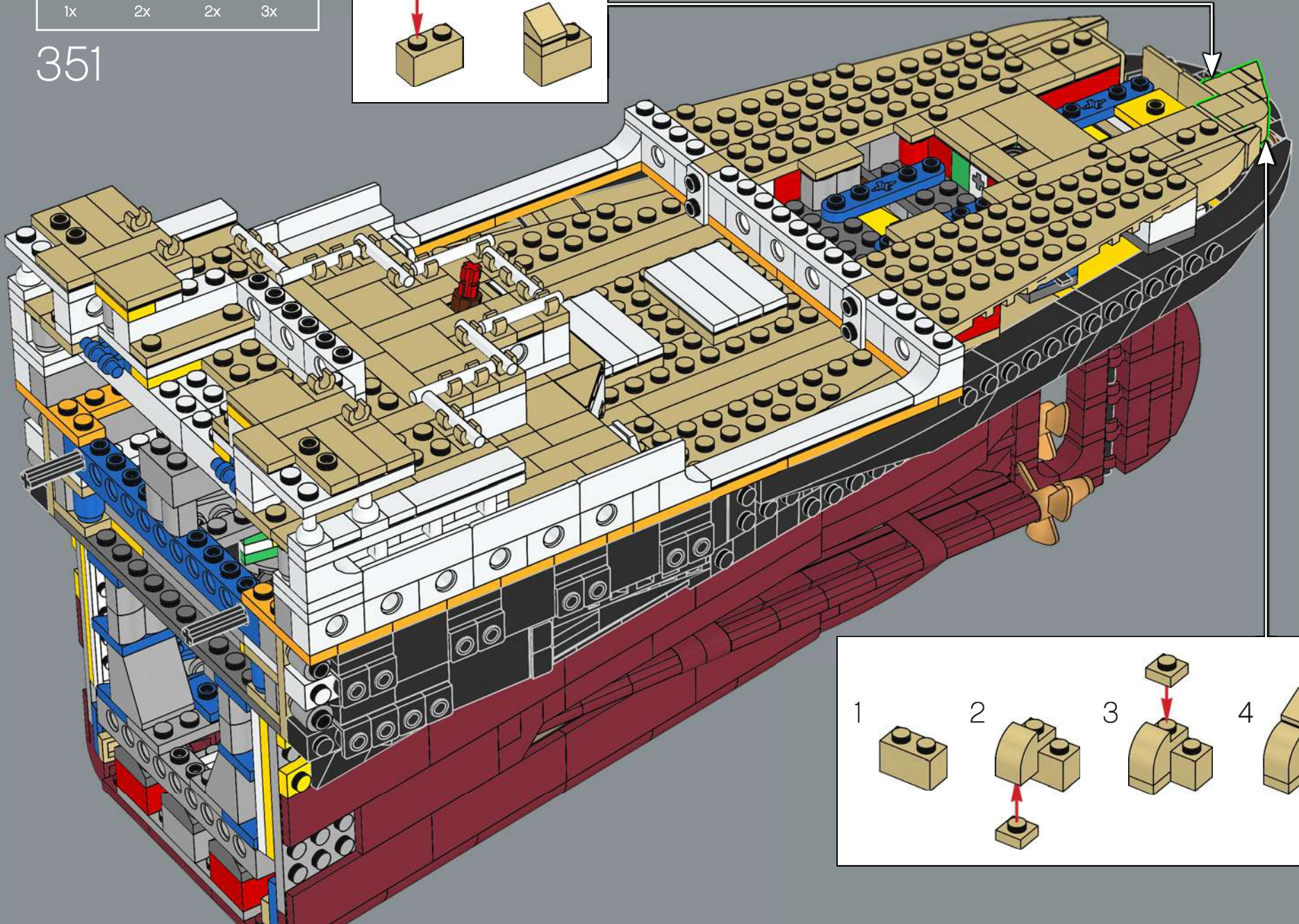
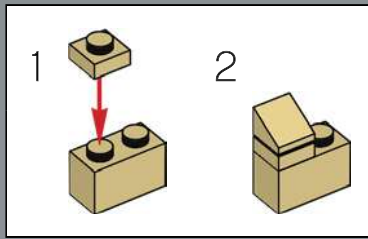

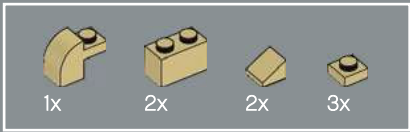

352

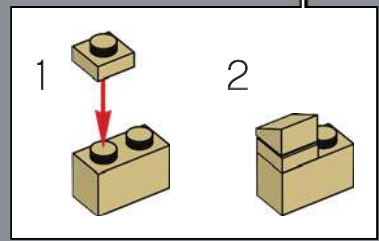
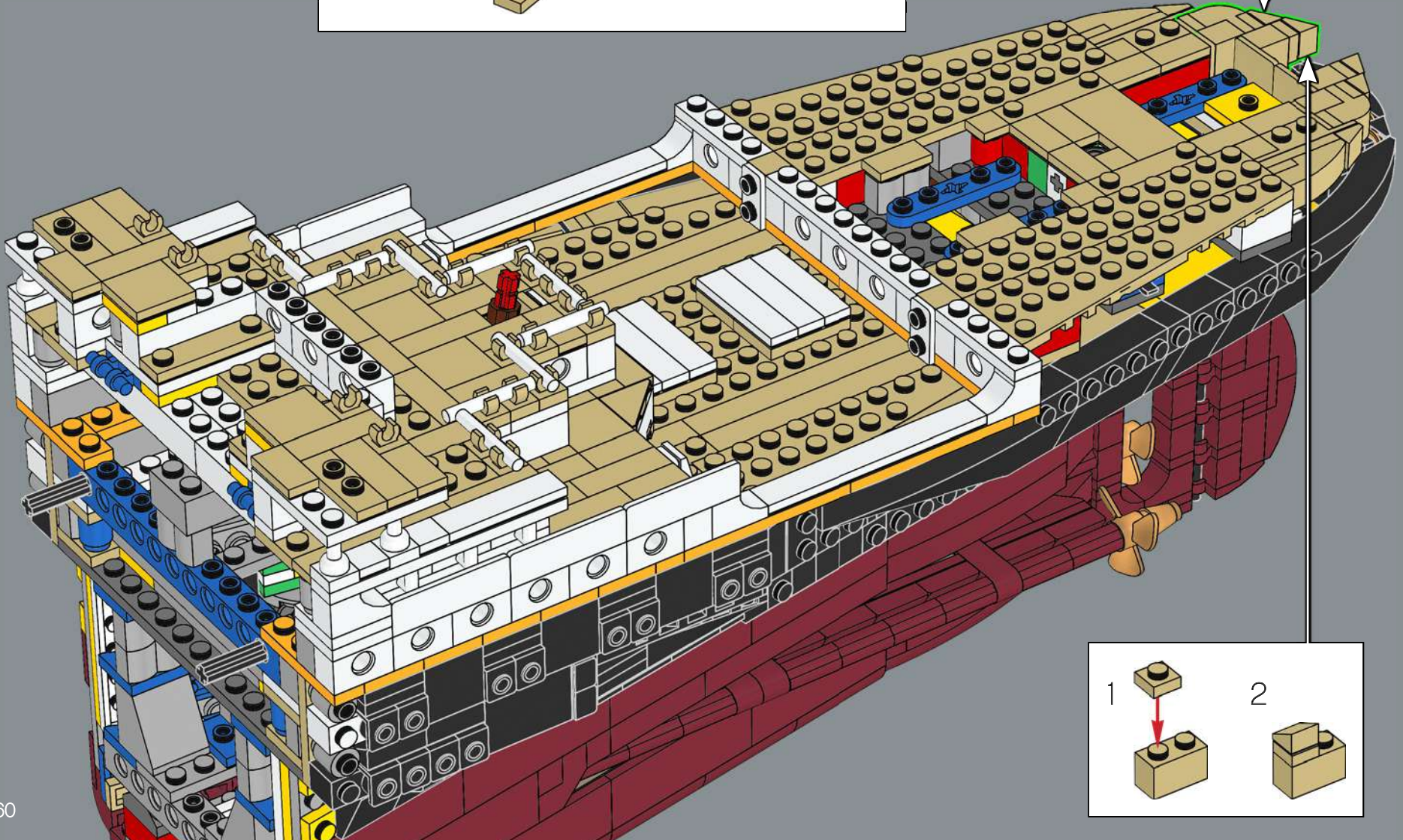
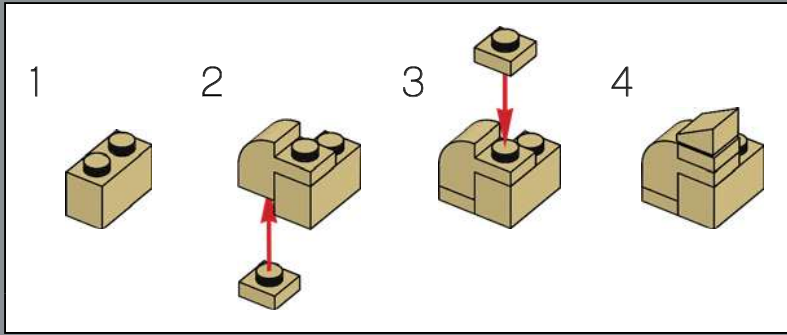

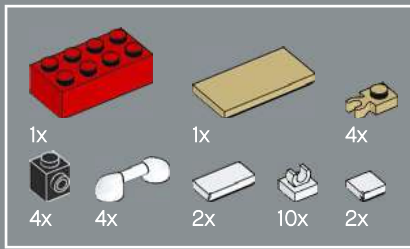

353

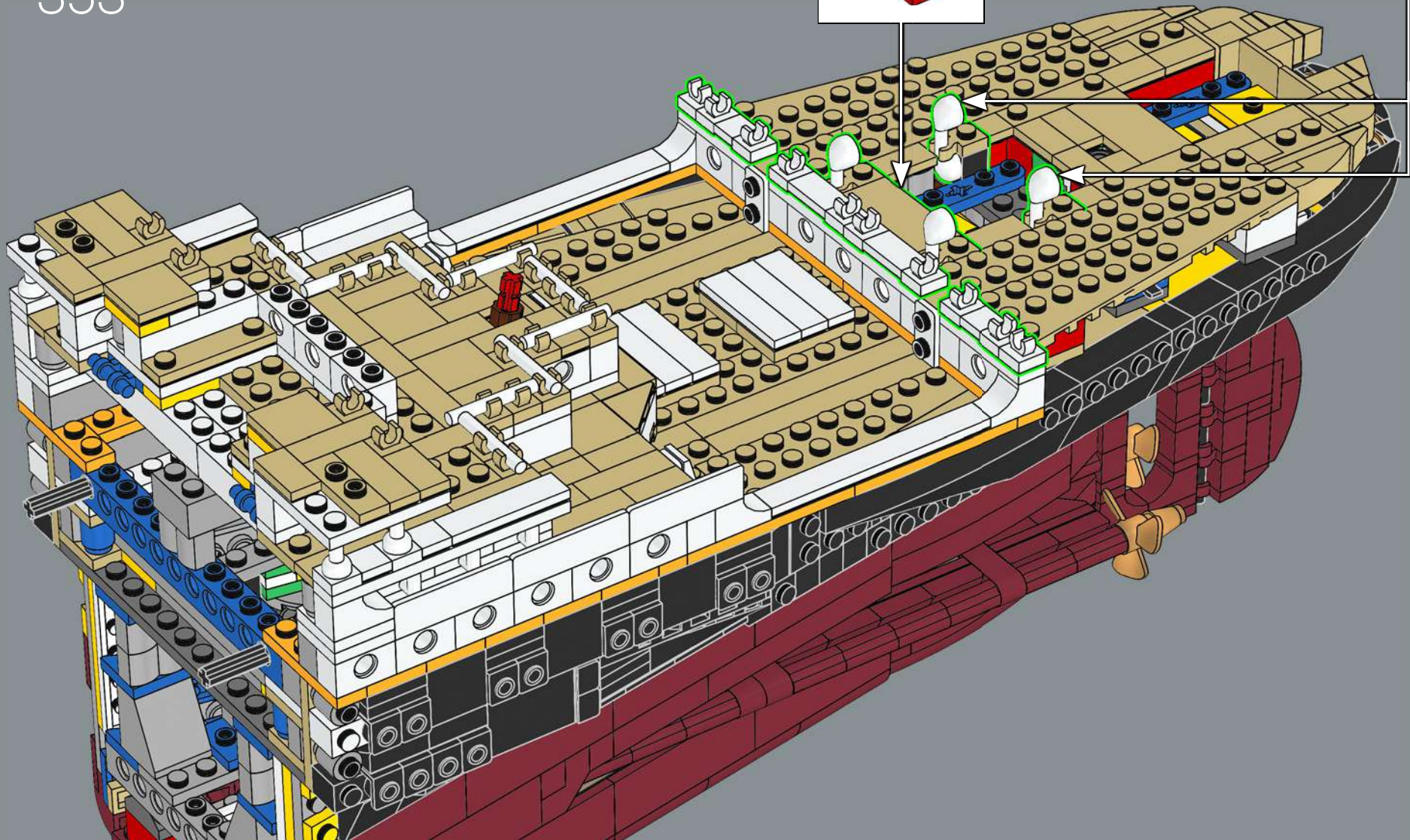
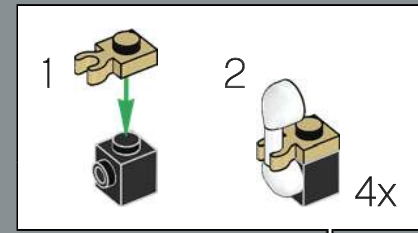
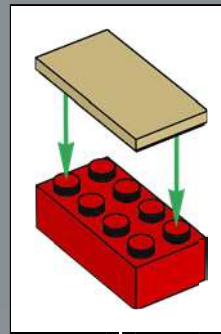



354

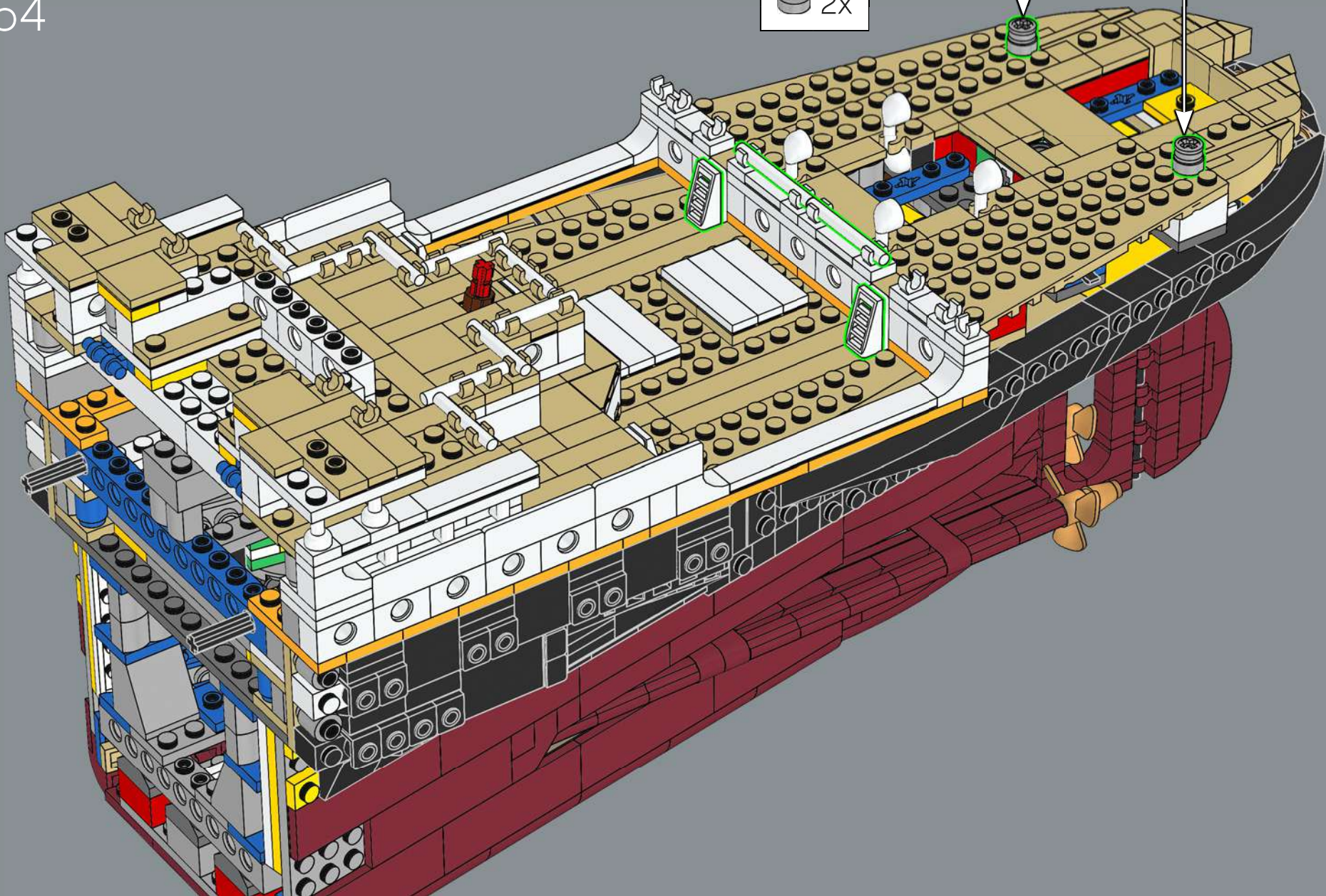
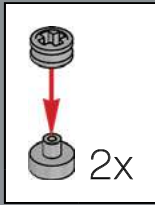

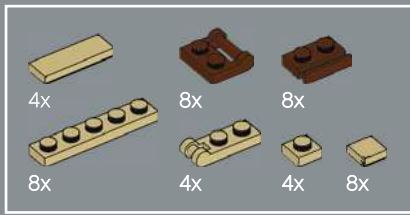

355

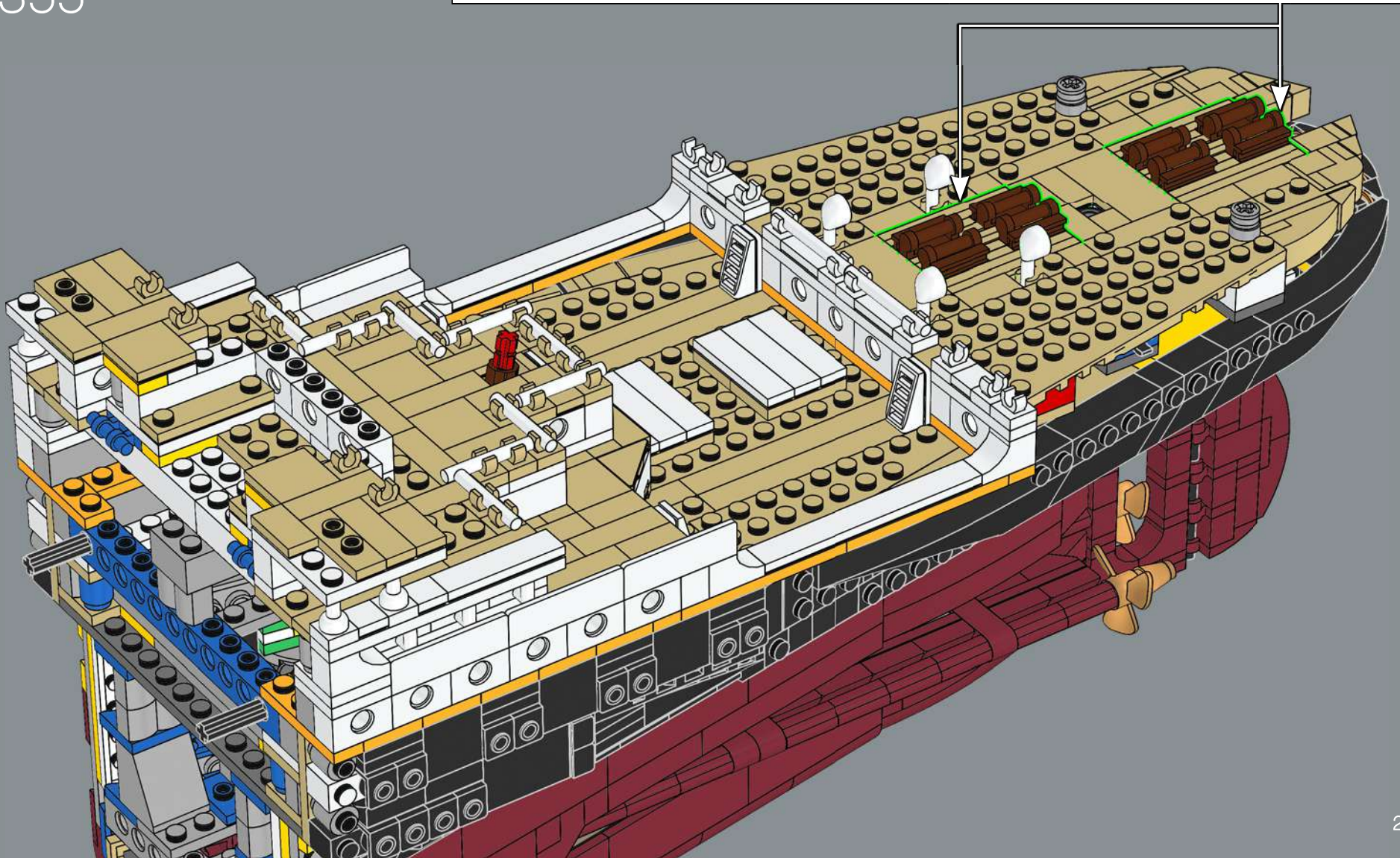
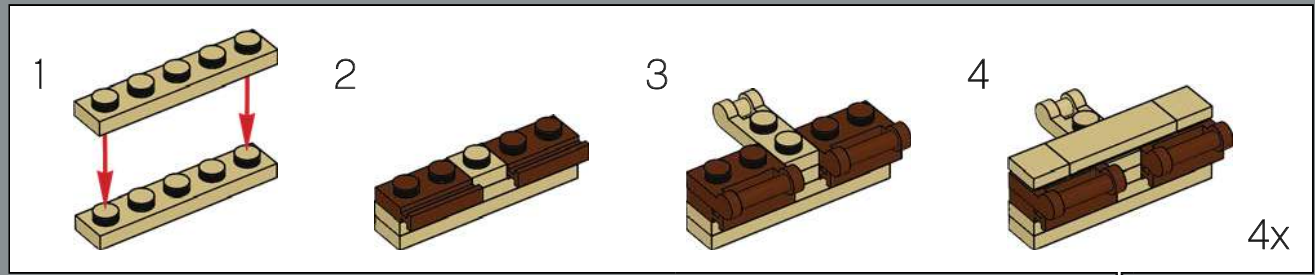

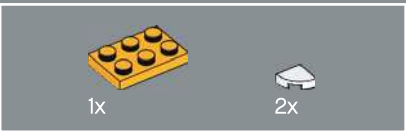
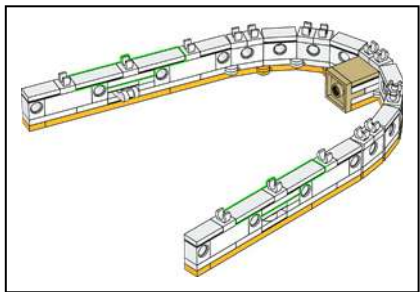
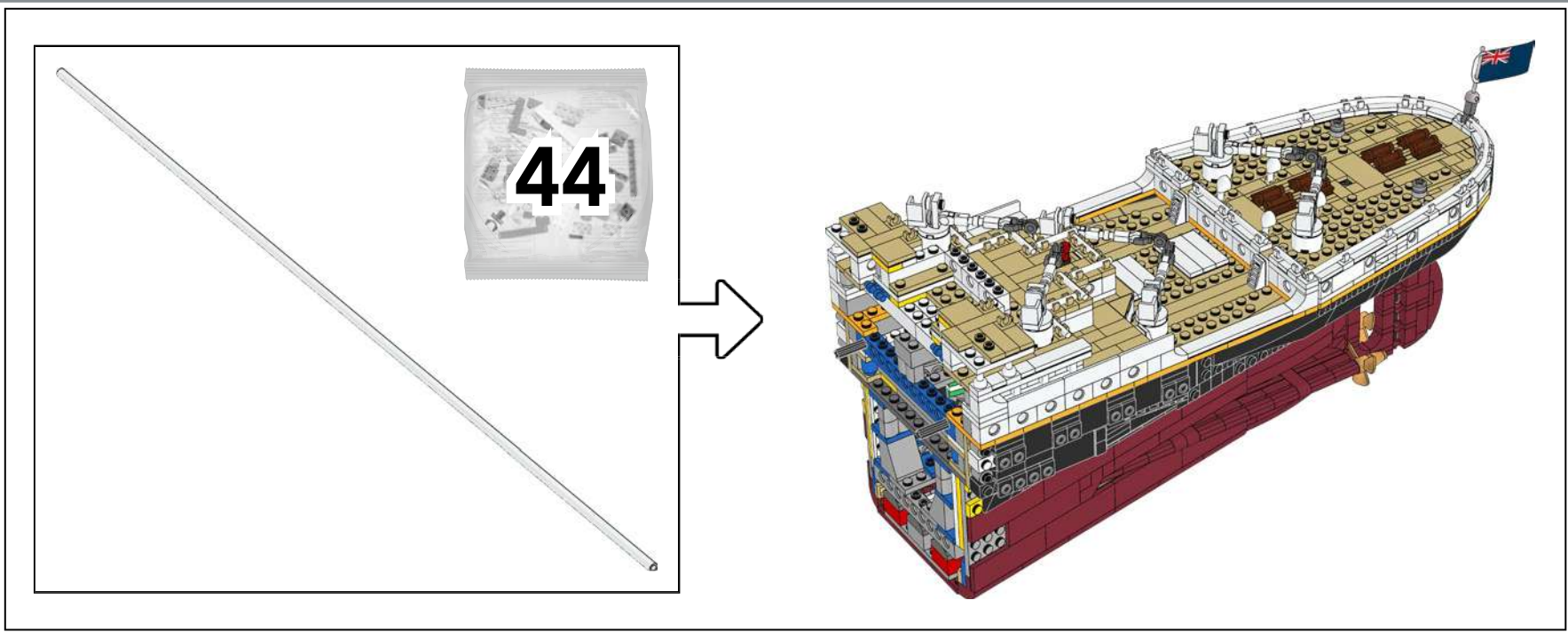

356

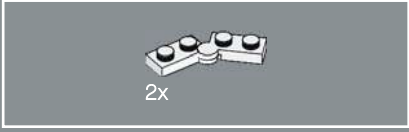
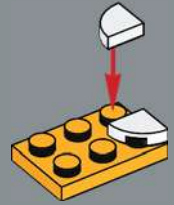

357

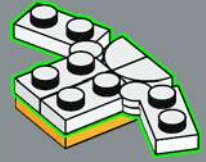

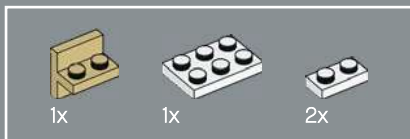

358

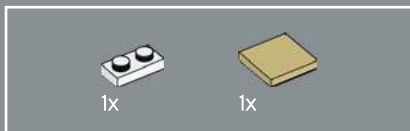
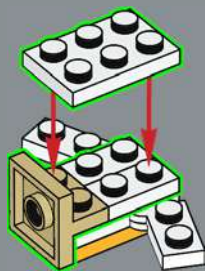

359



360

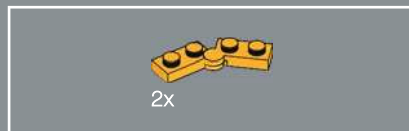

361

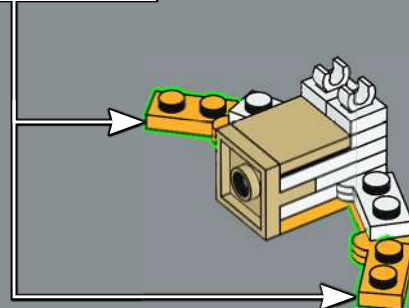
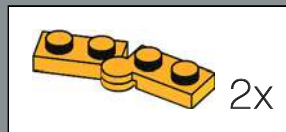



362

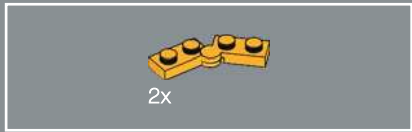
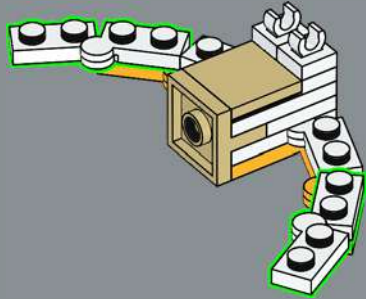

363

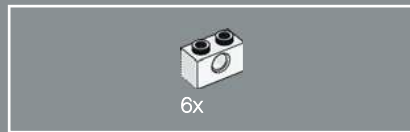
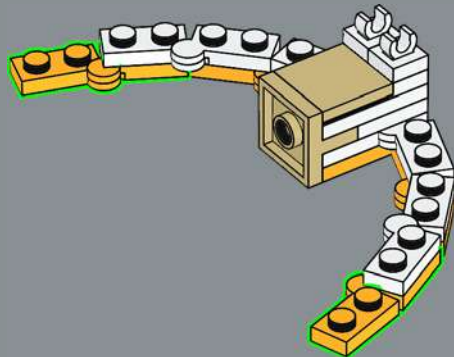

364

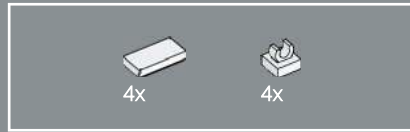
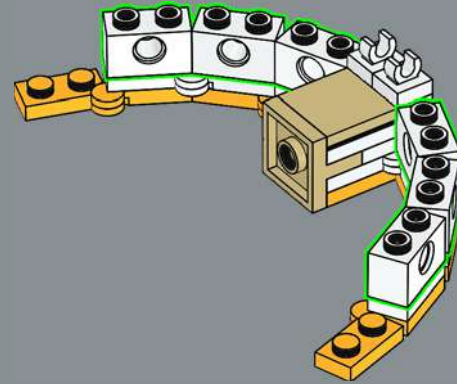

365

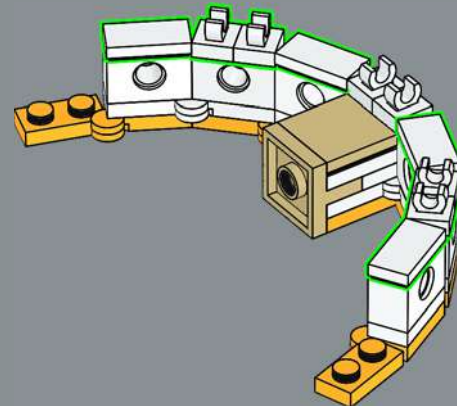

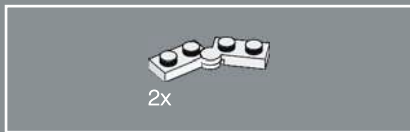

366

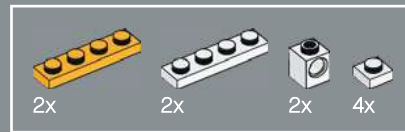
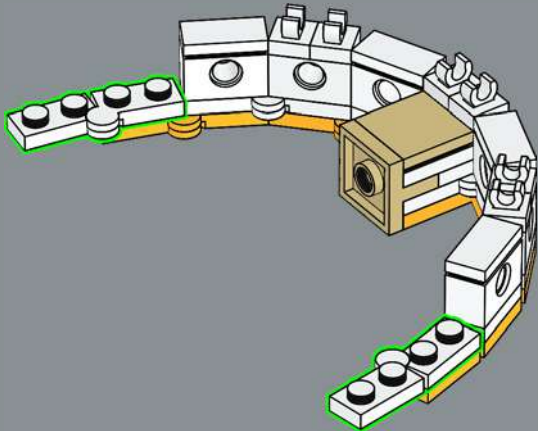

367

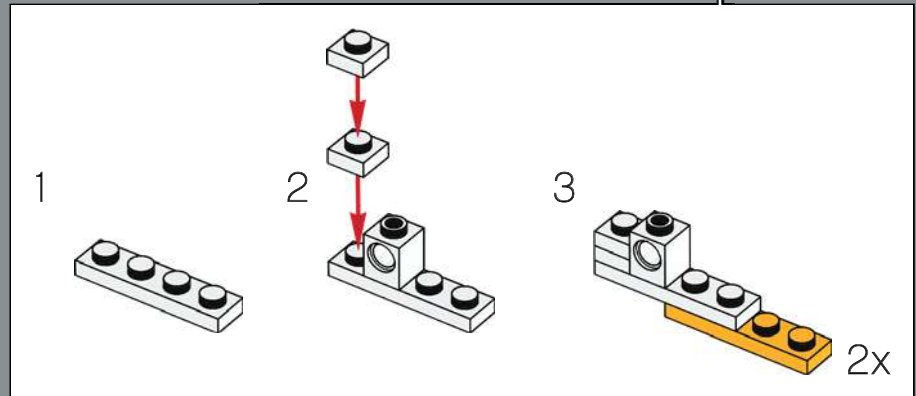
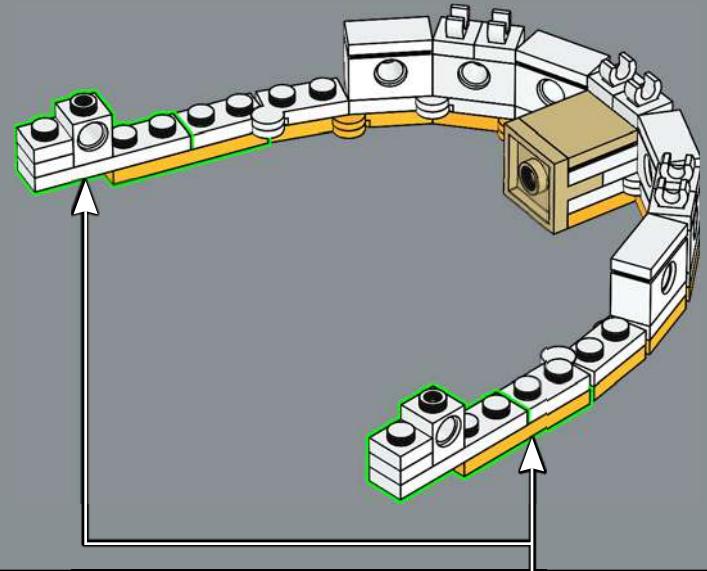

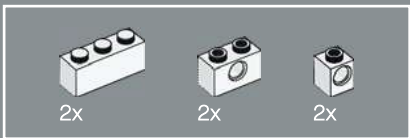

368

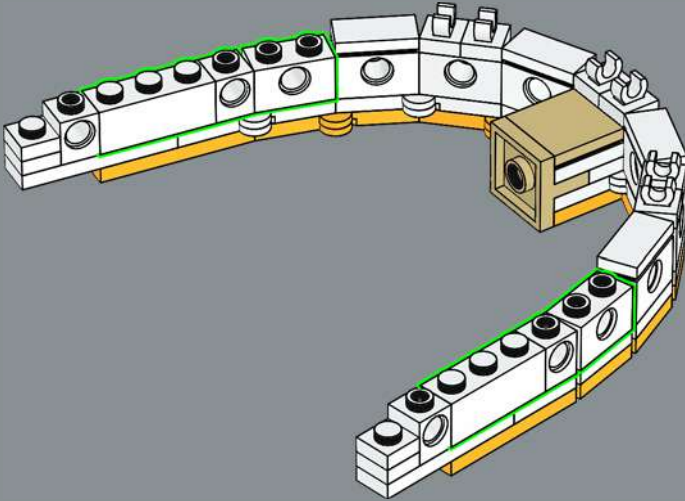

369

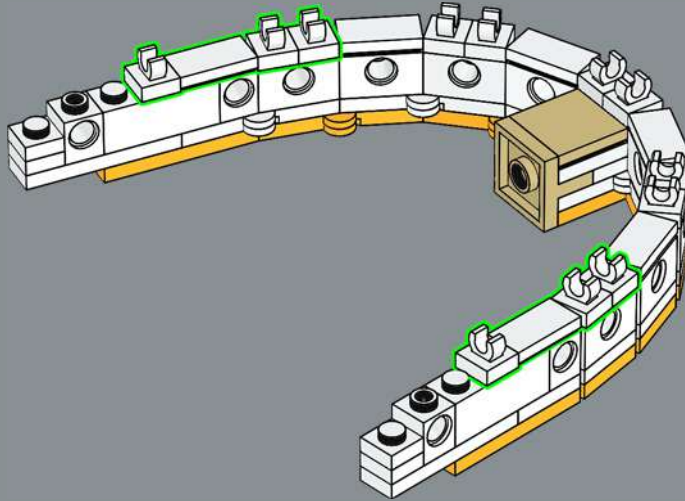

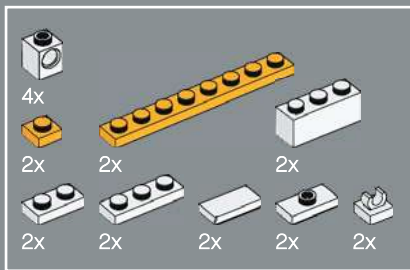

370

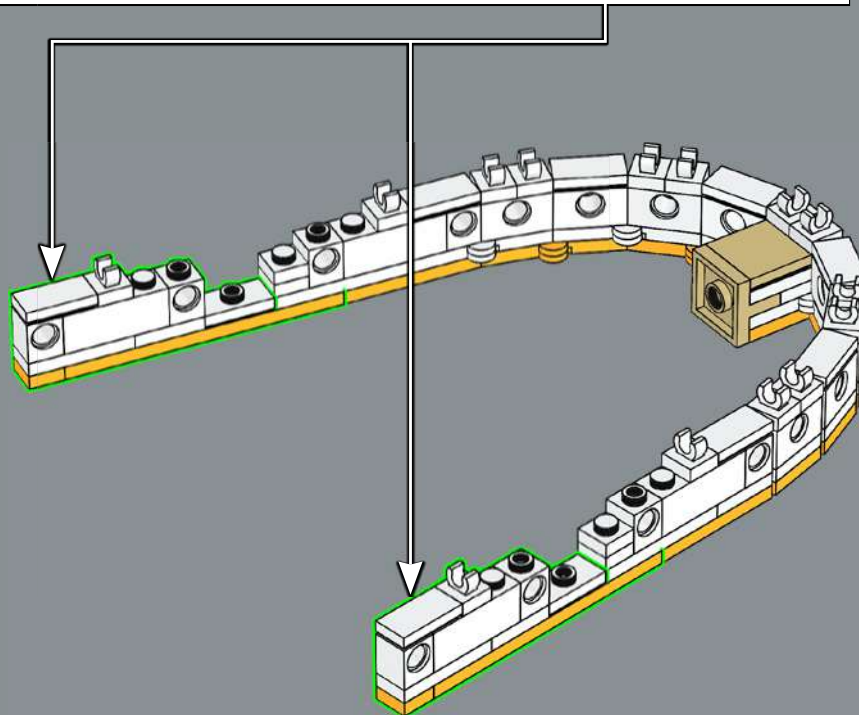
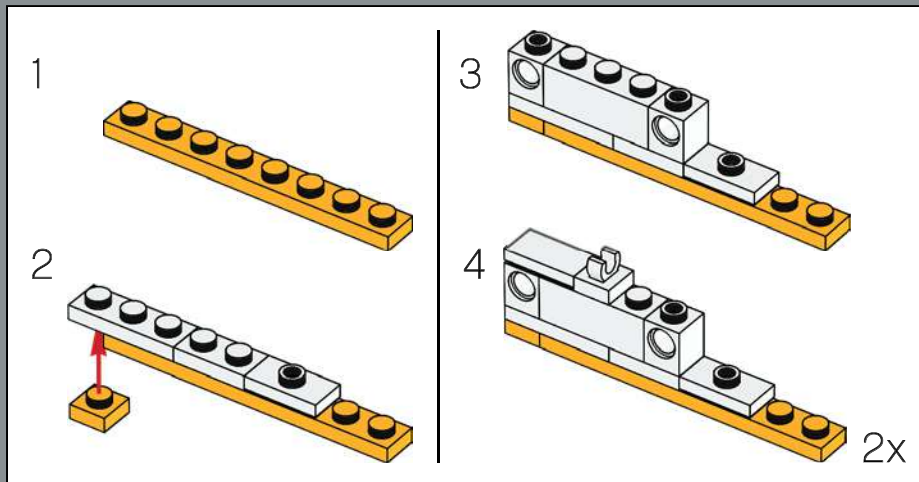



371

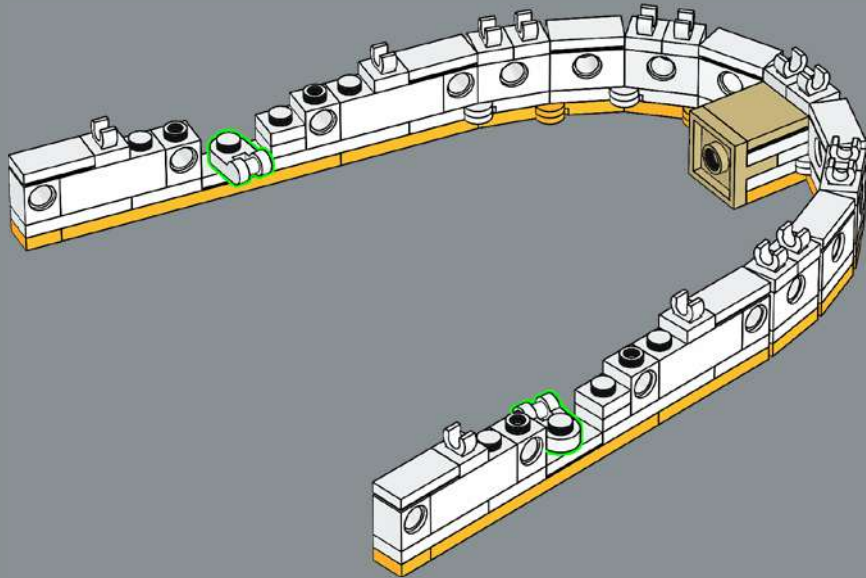

372

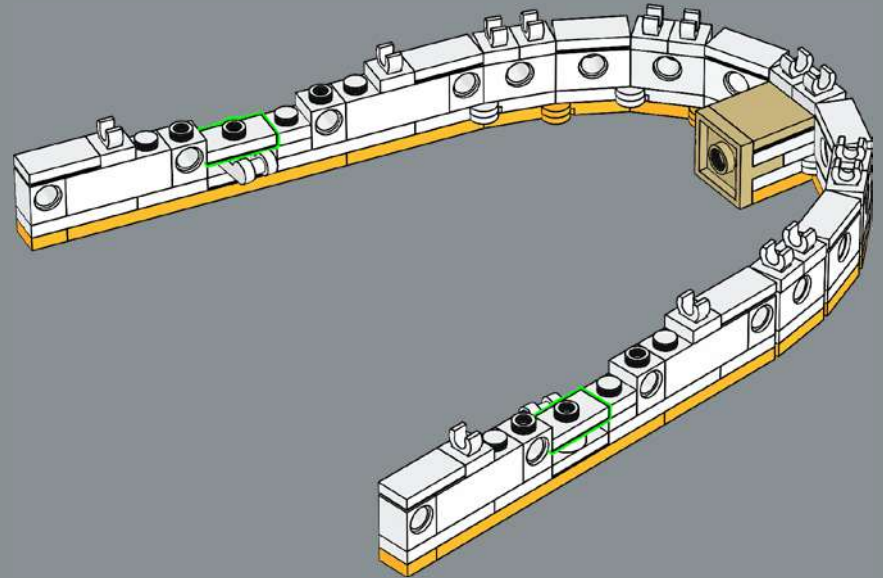

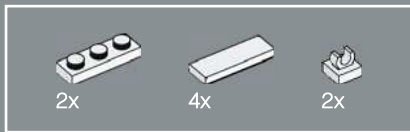

373

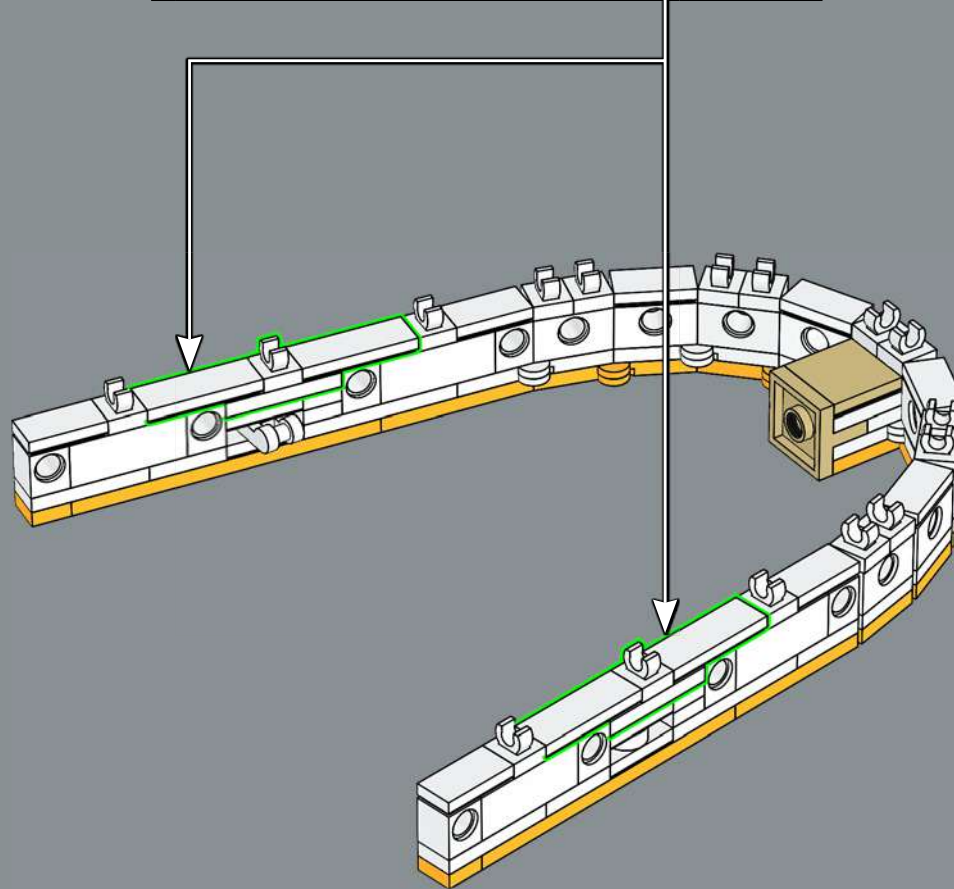
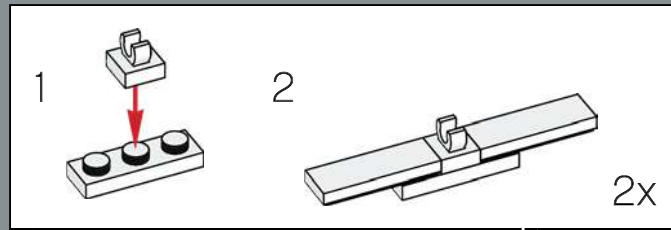

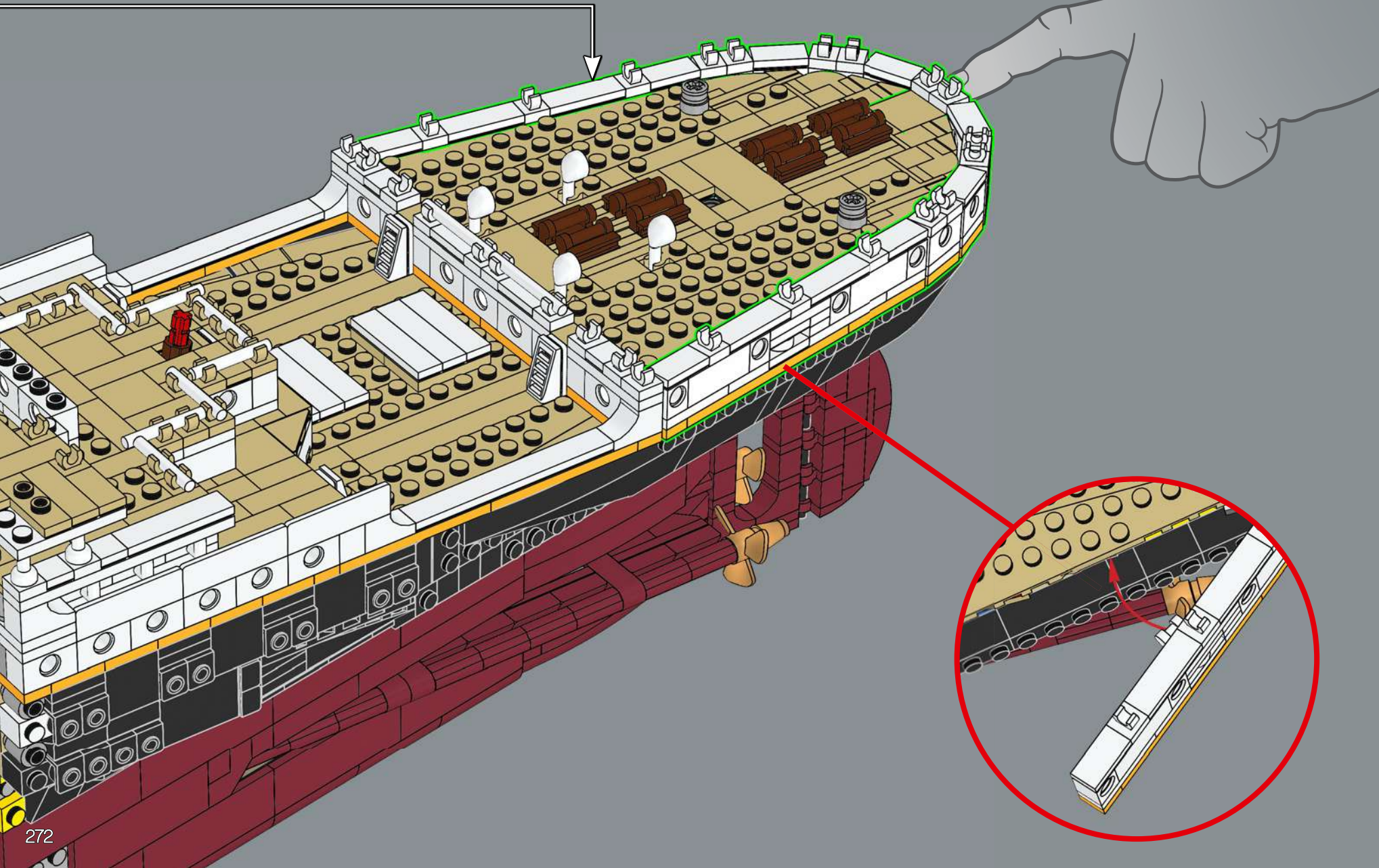

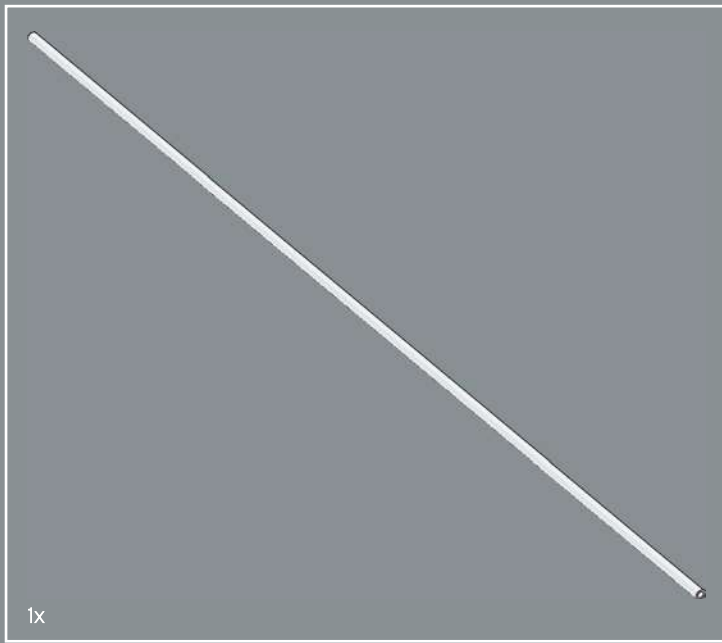

1x

375

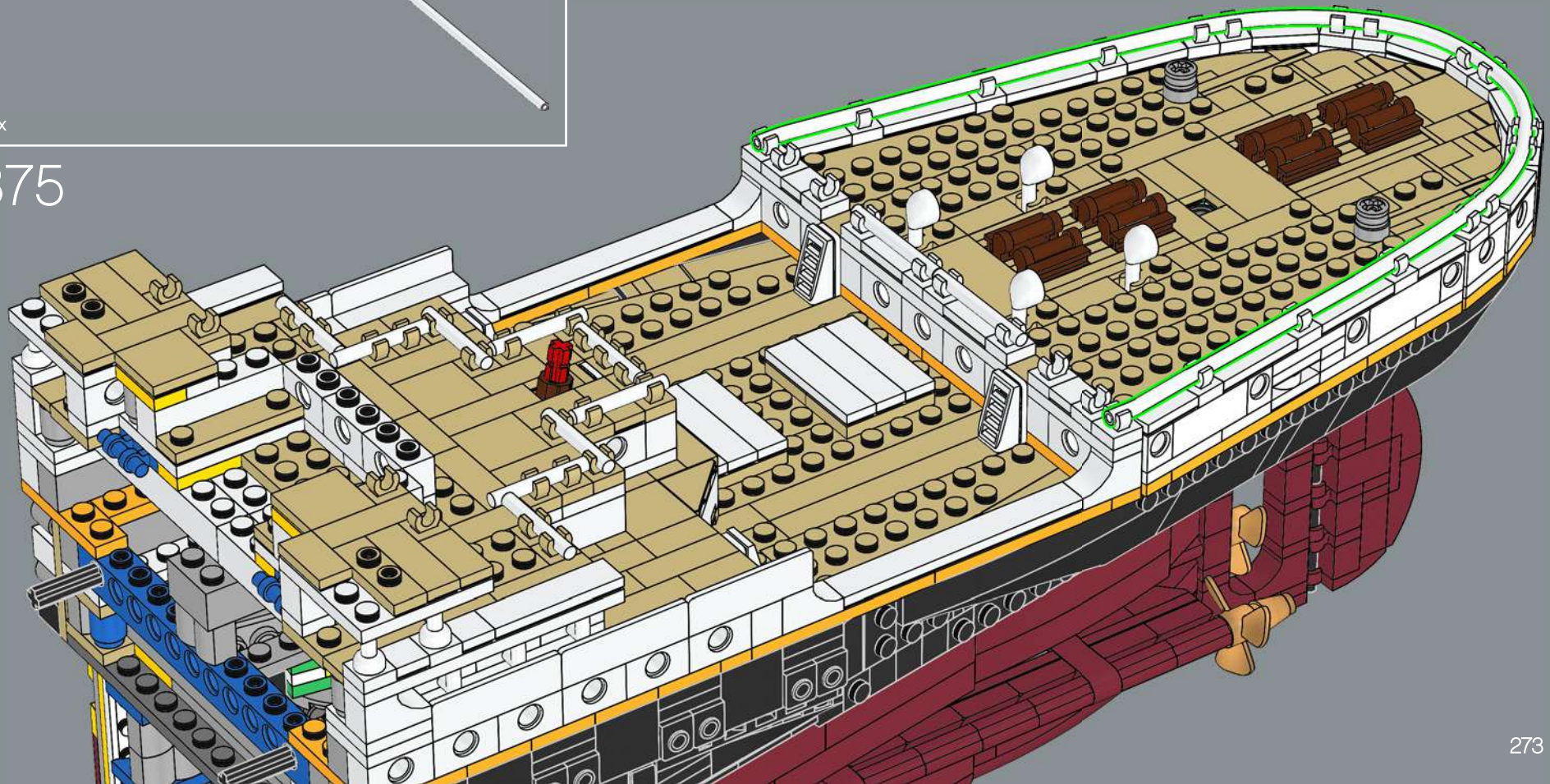



376

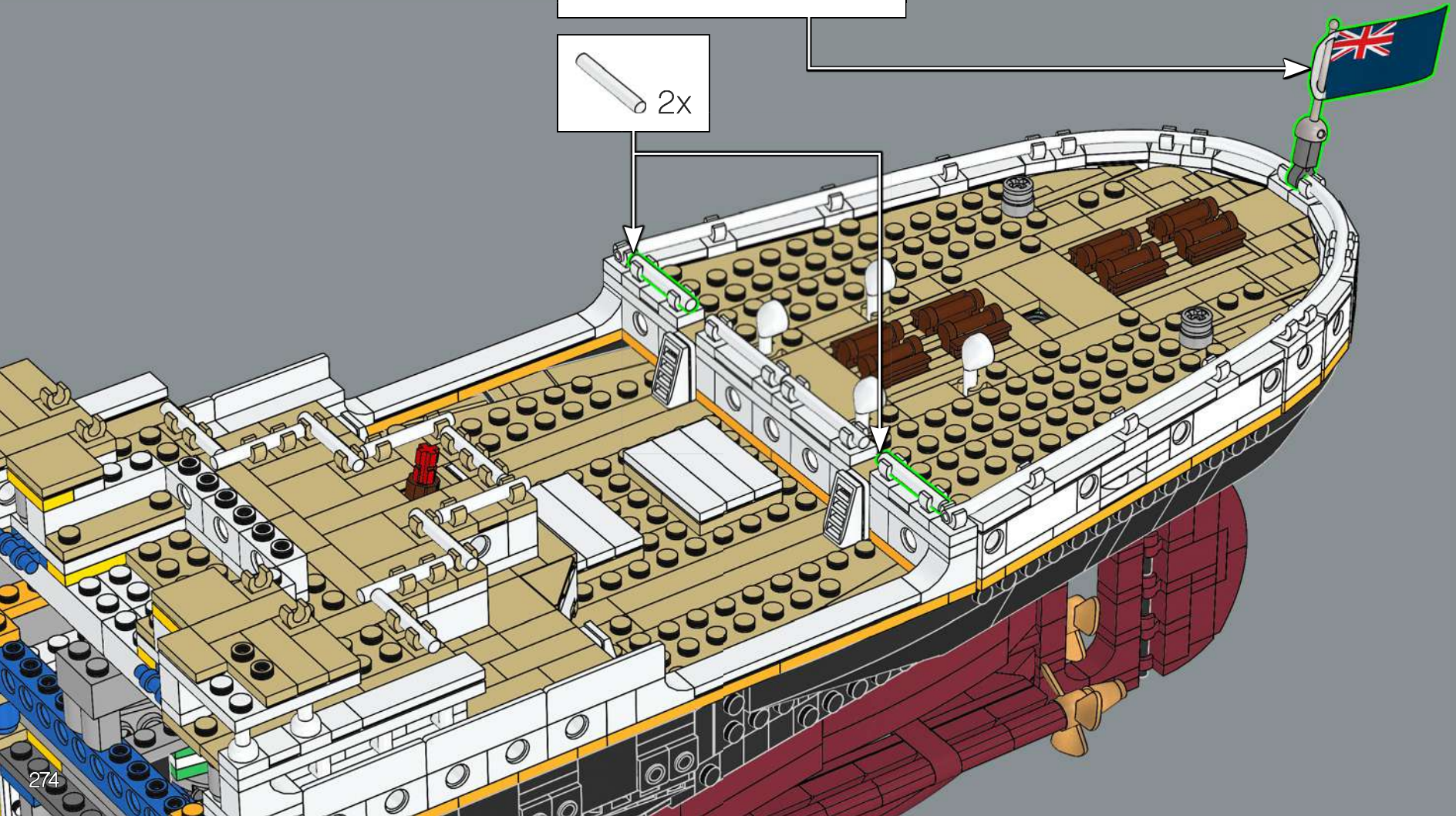
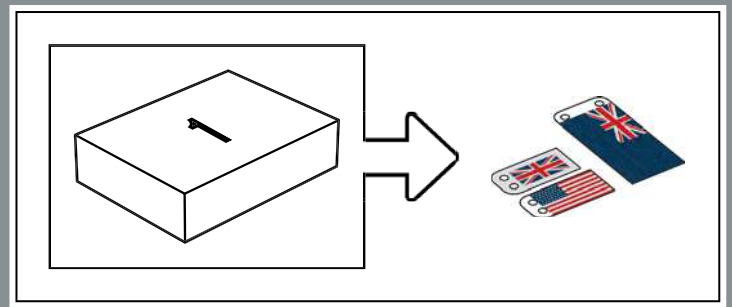
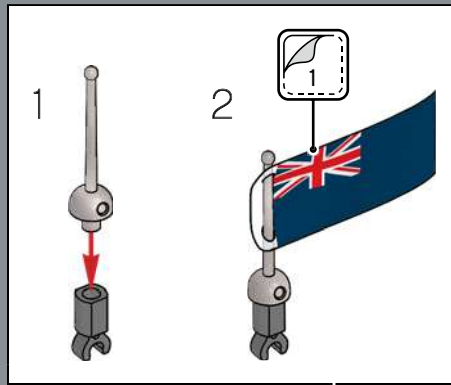

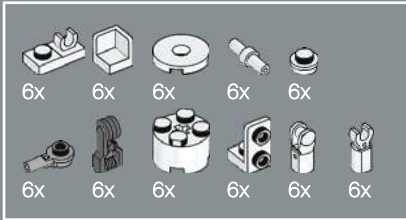
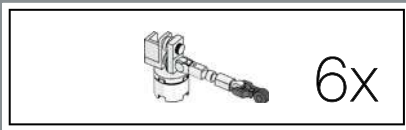

377

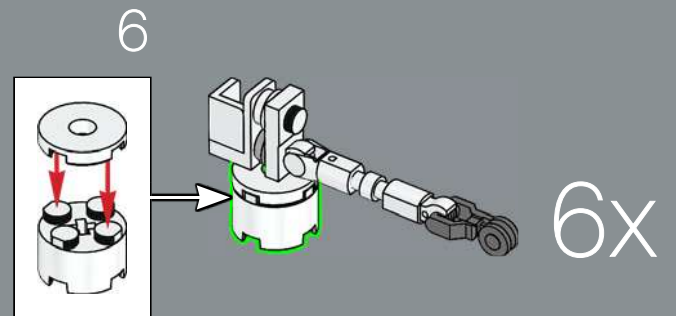
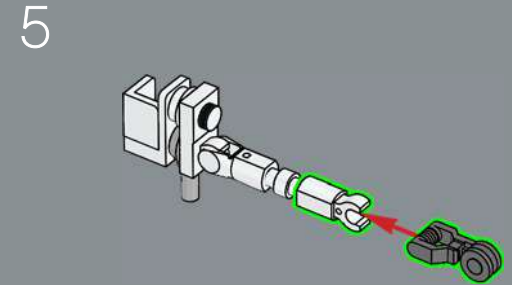
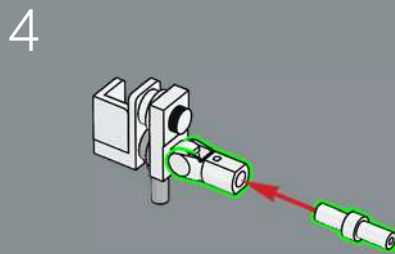
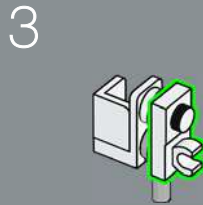
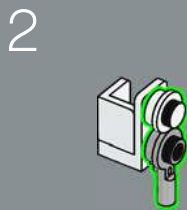
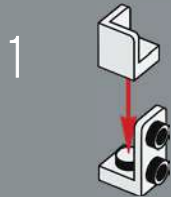

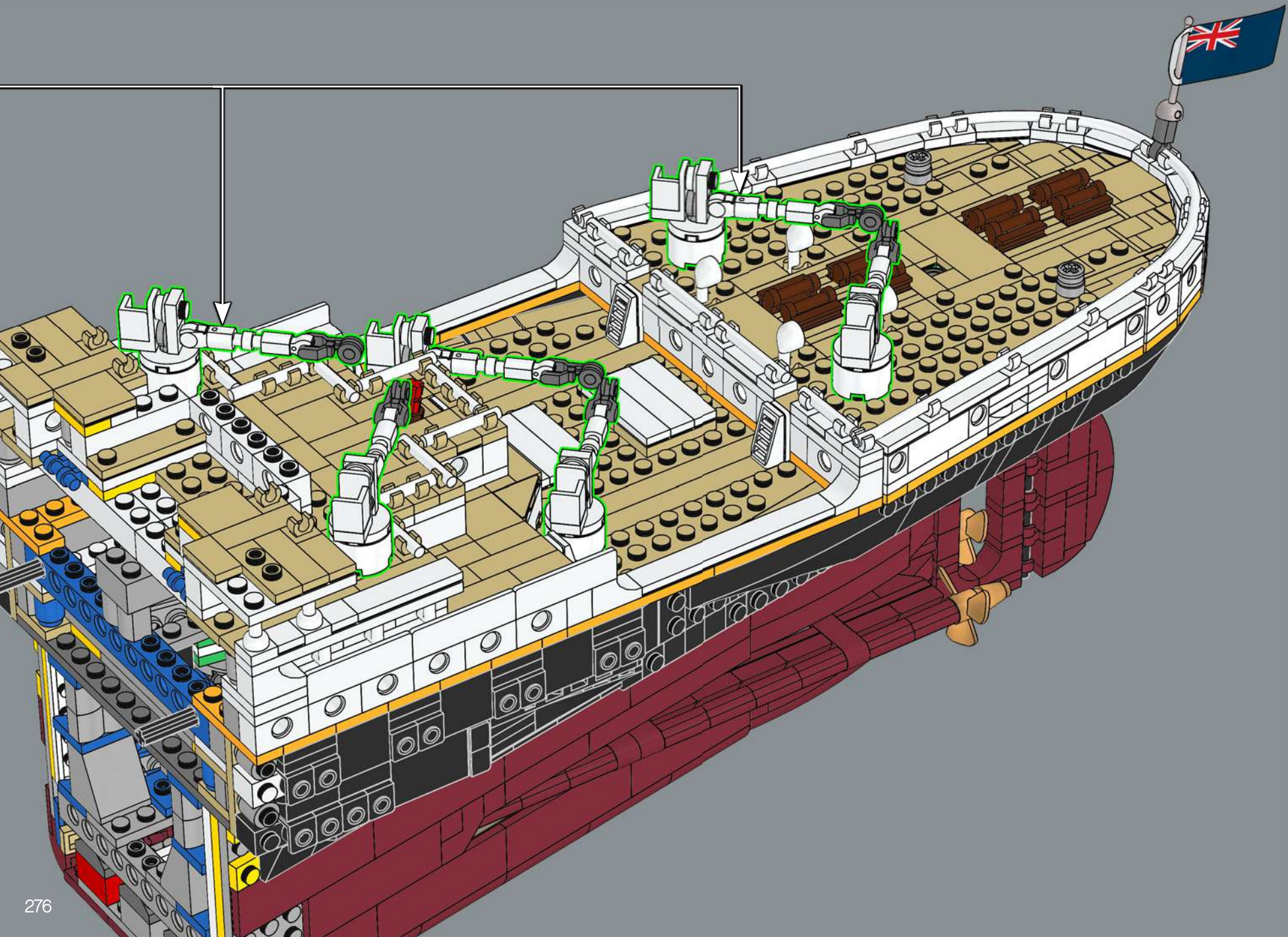

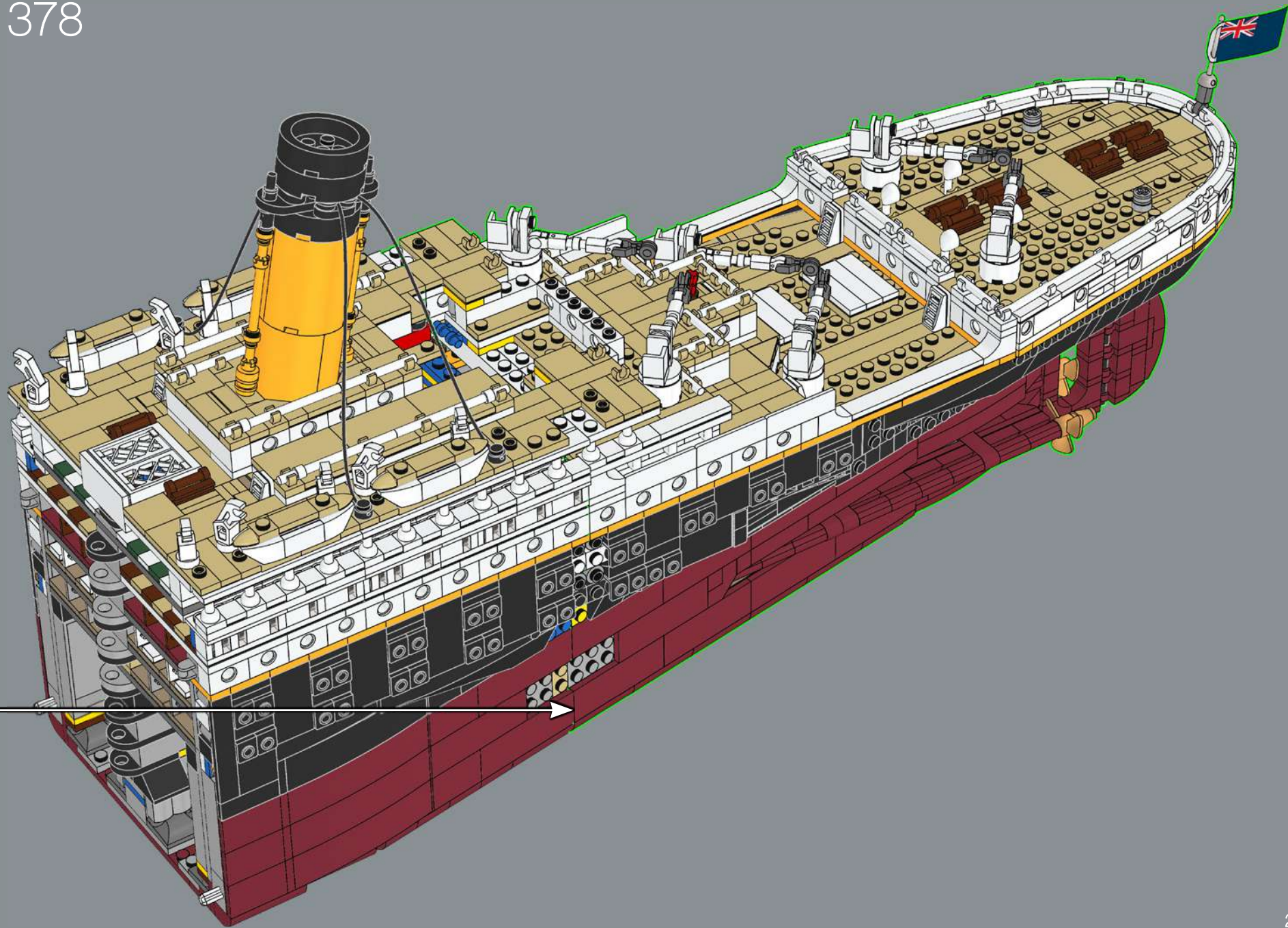

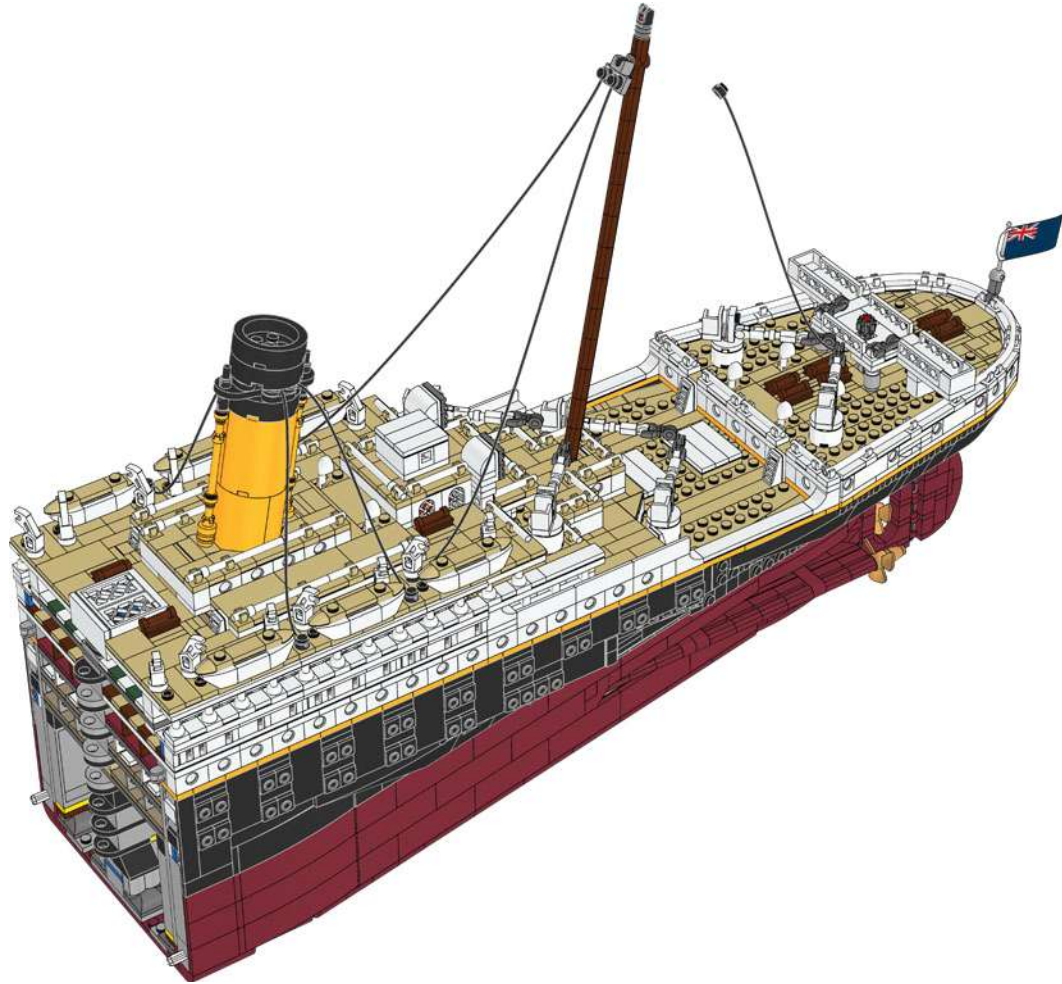
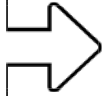

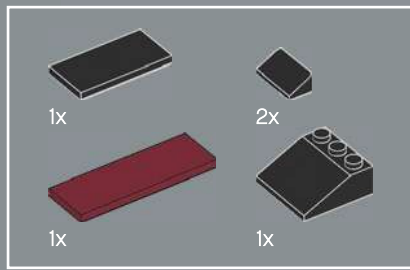

379

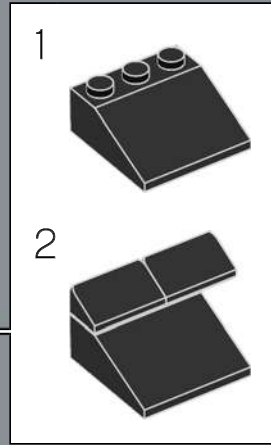
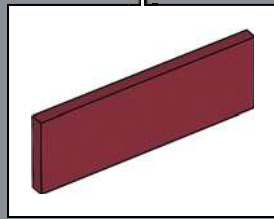
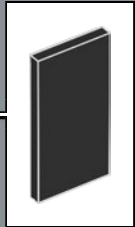
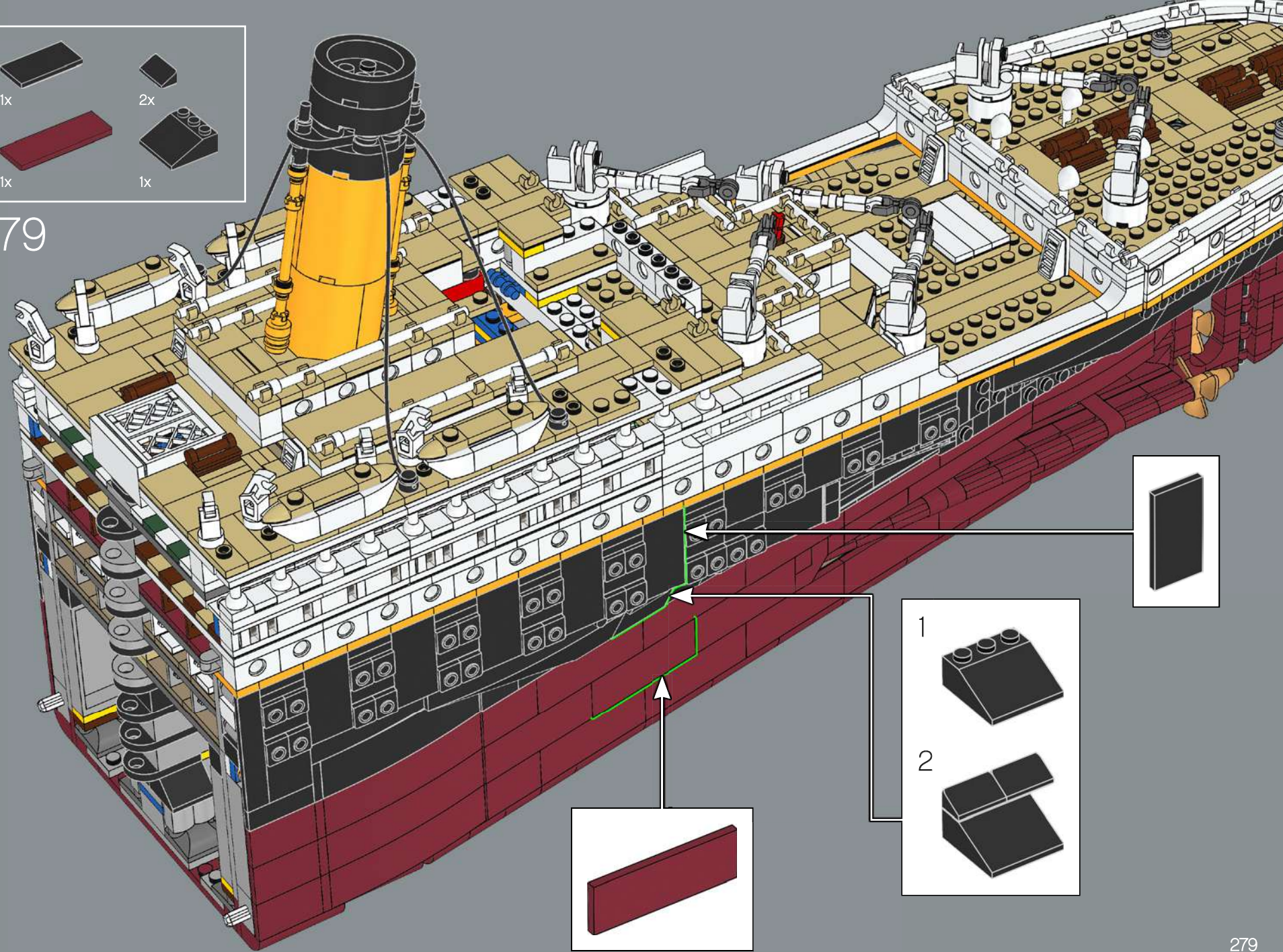

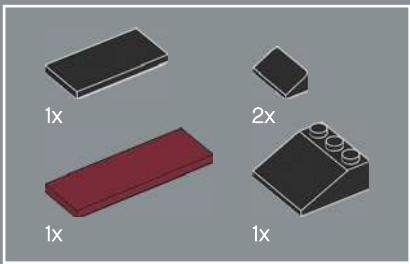

380

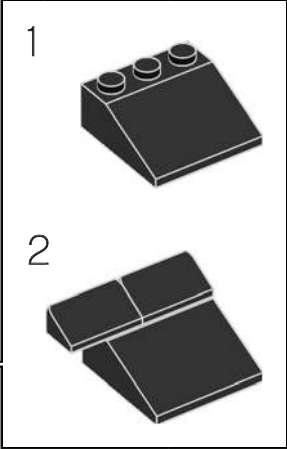
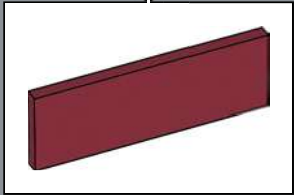
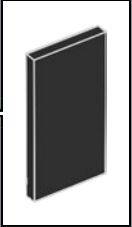
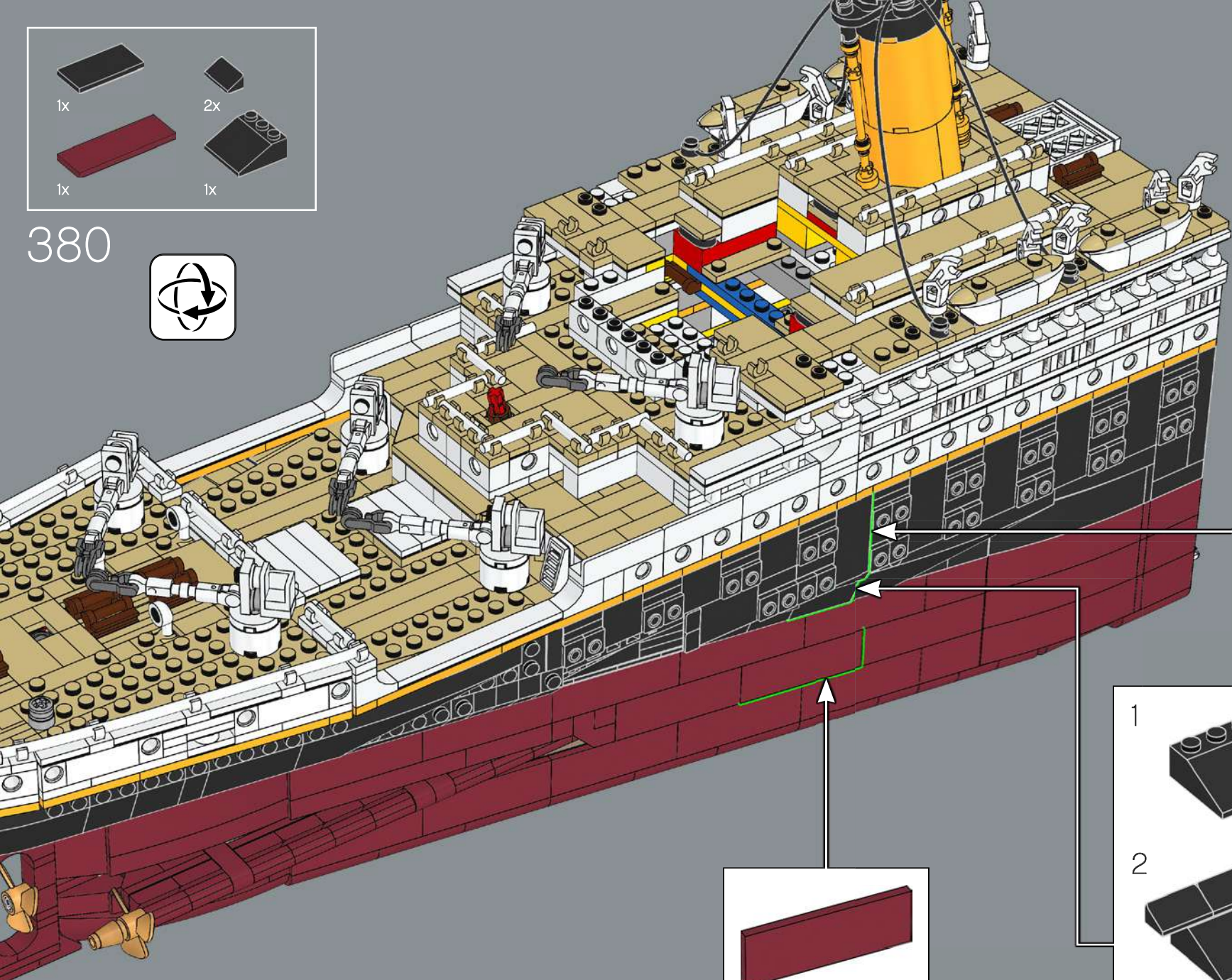

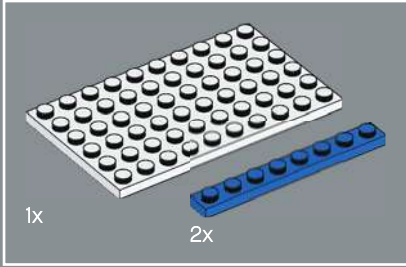
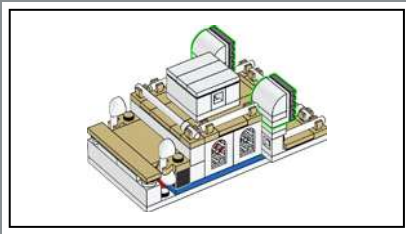

381

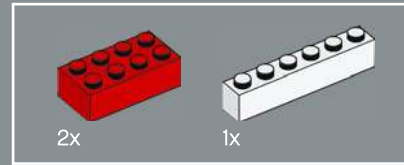
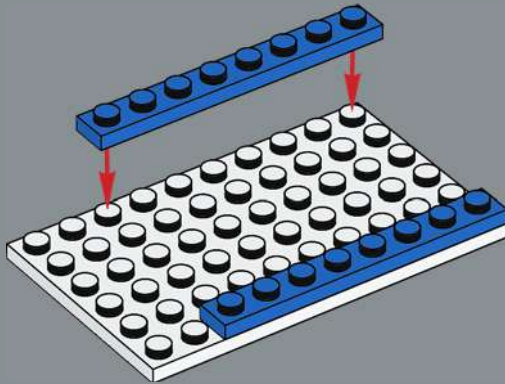

382

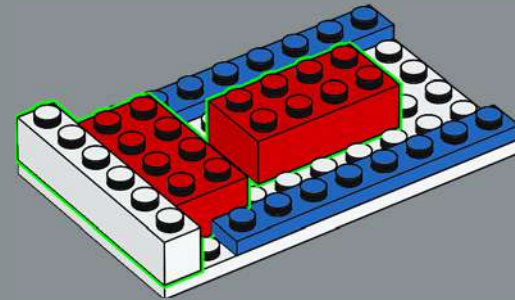

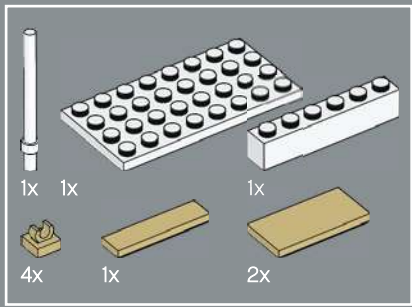

383

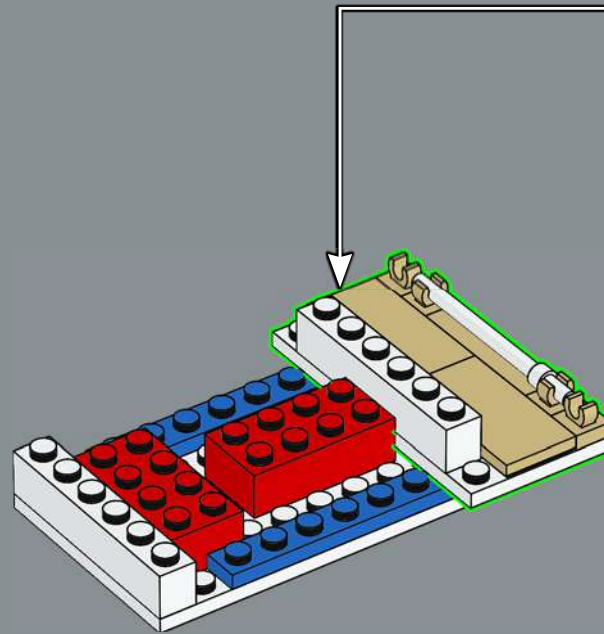
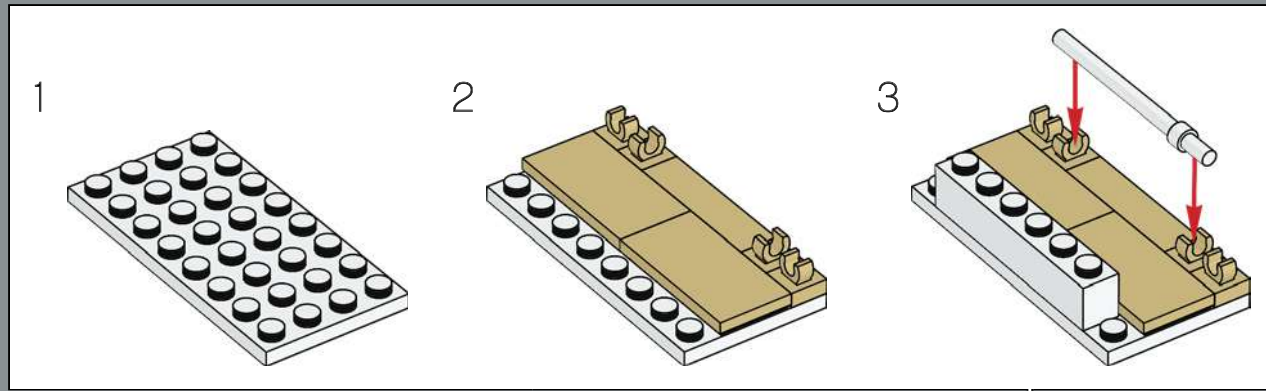

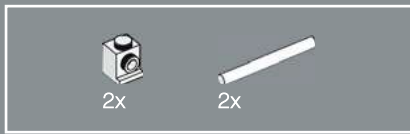

384

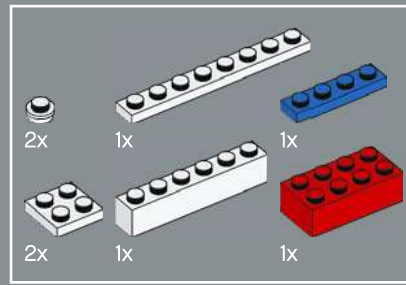
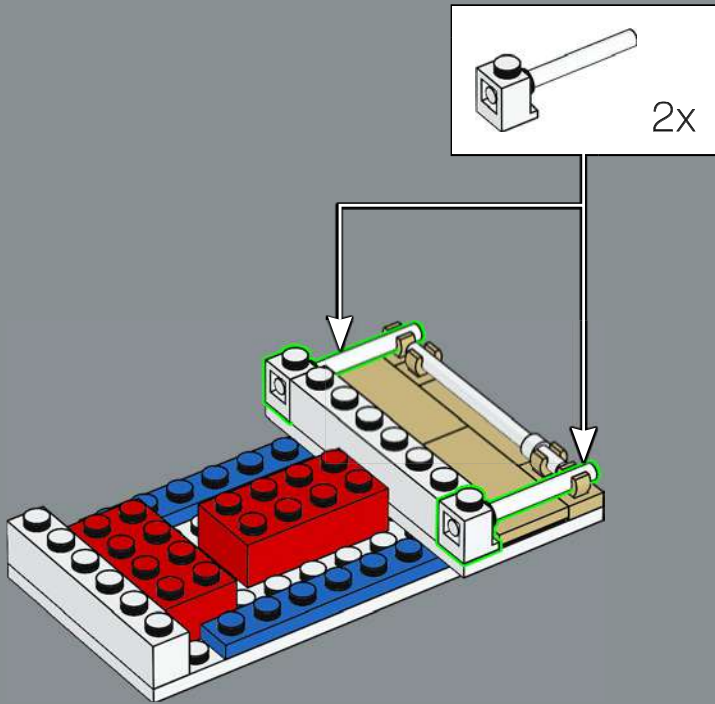

385

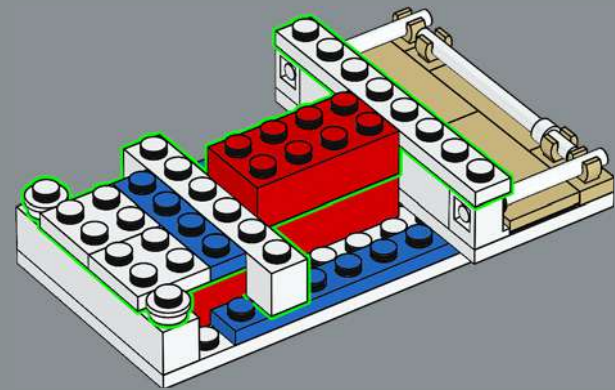

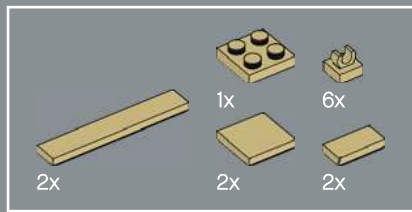

388

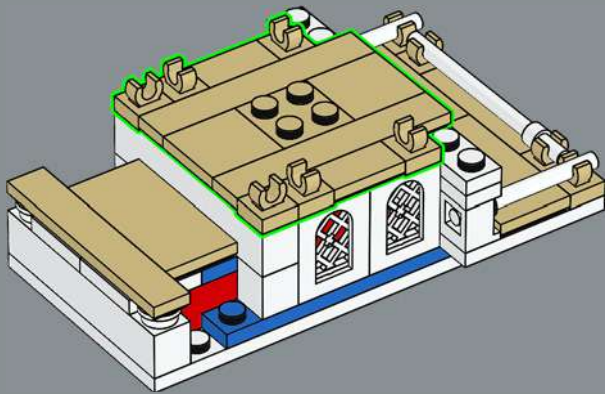

389

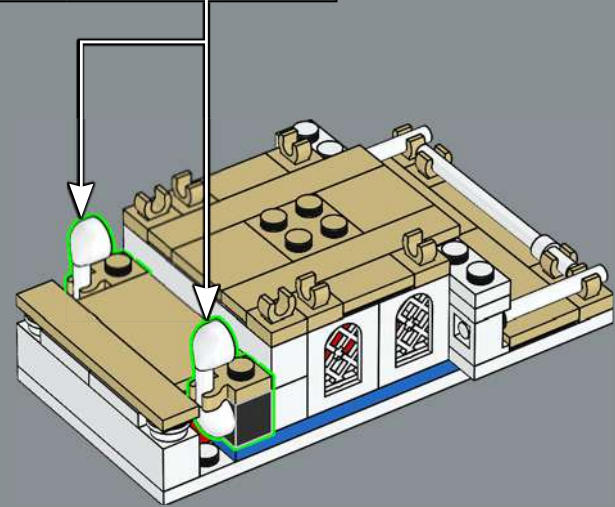
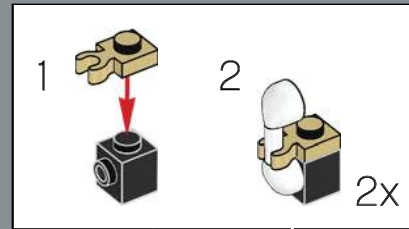

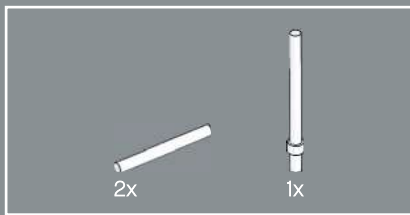

390

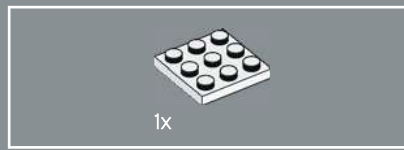
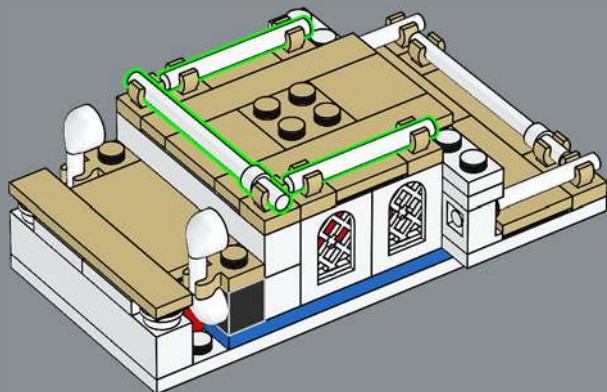

391

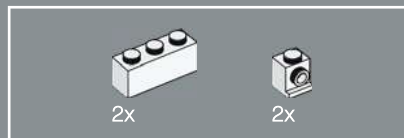
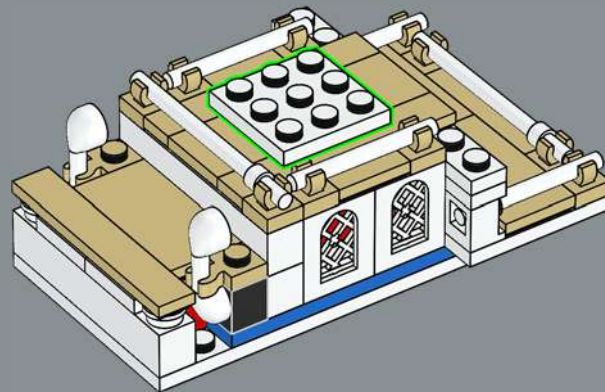

392

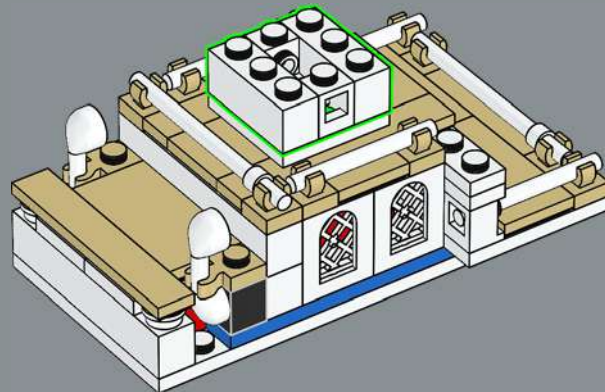

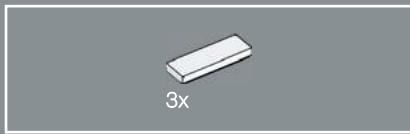

393

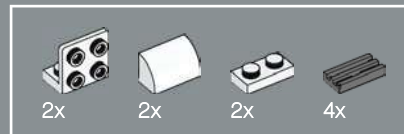
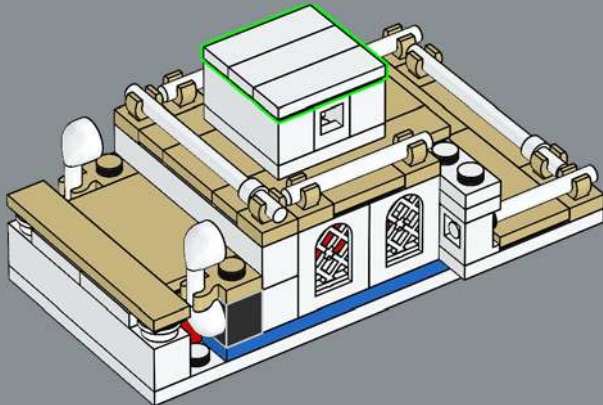

394

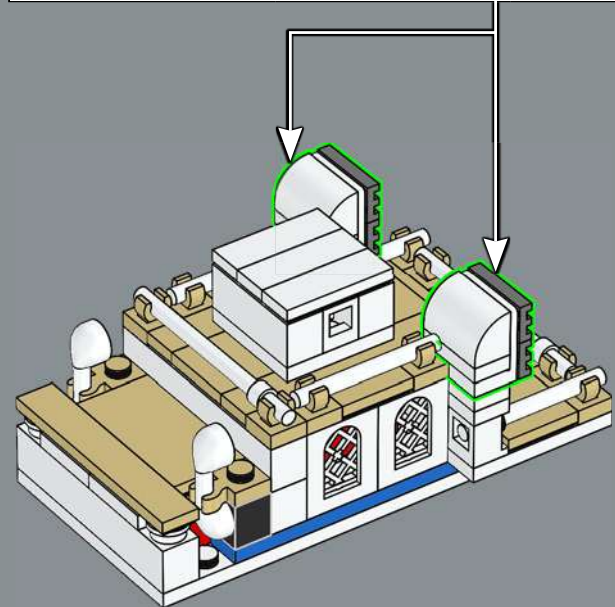
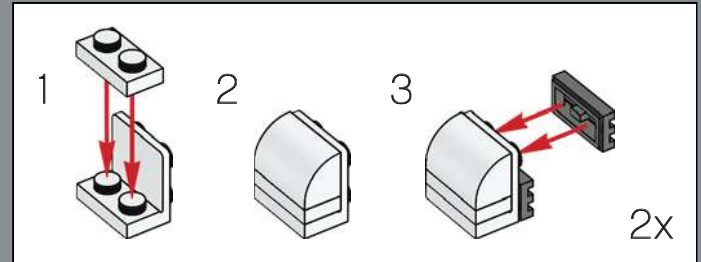

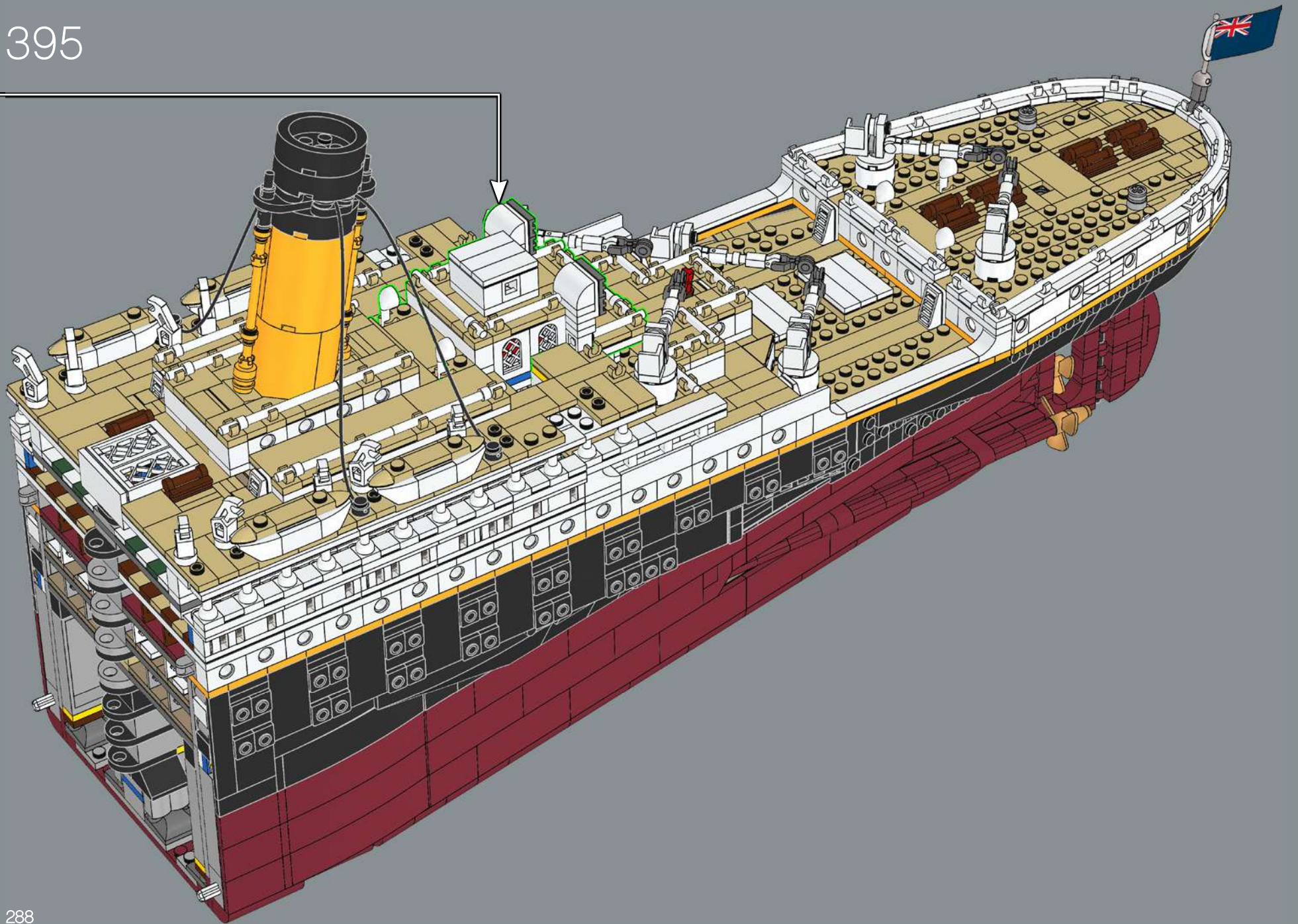

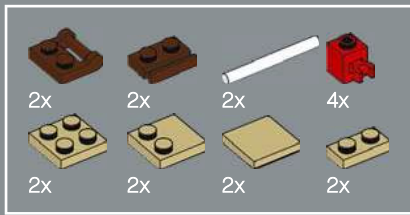

396

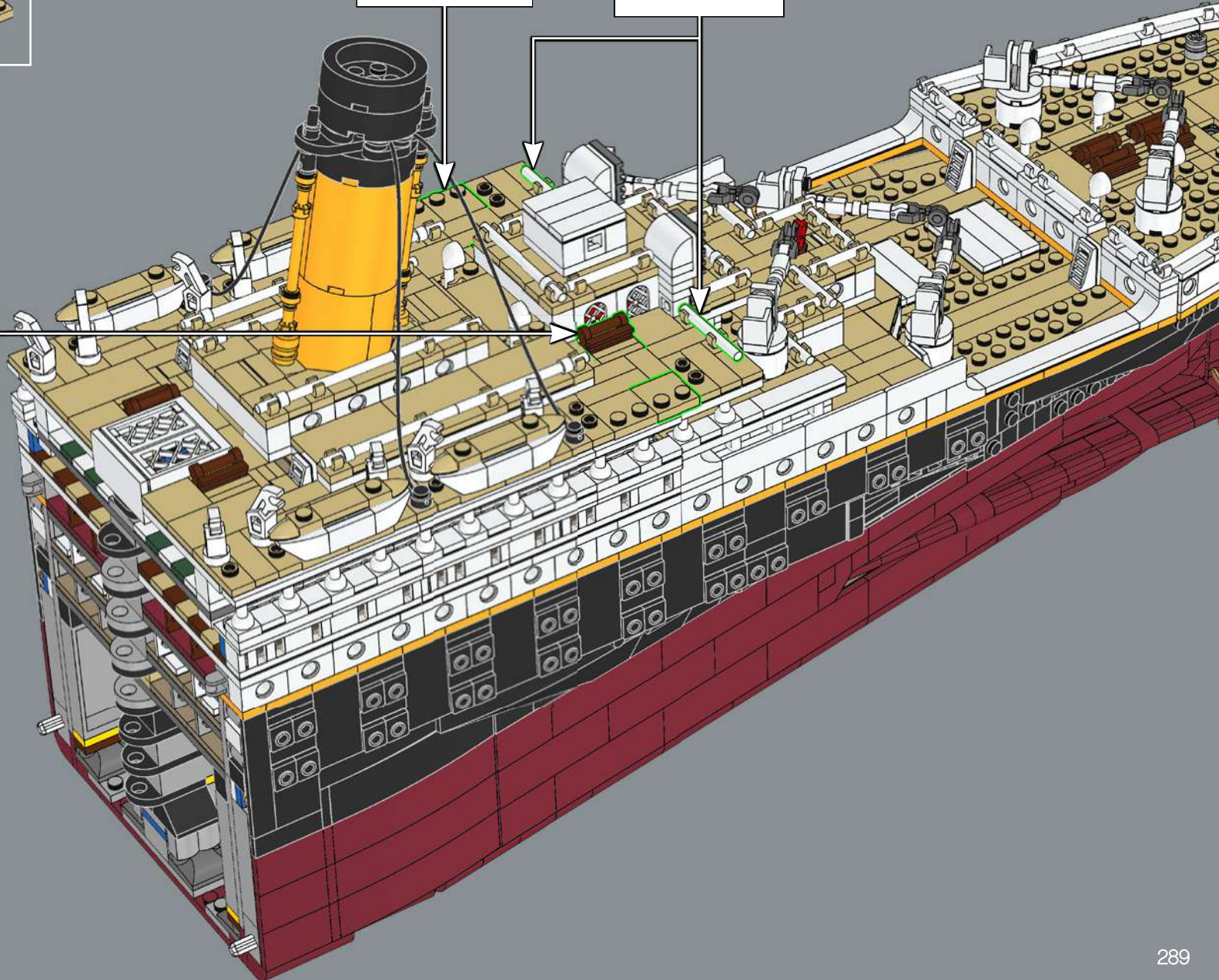
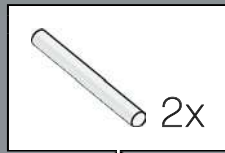
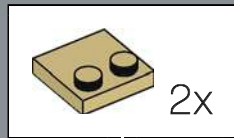
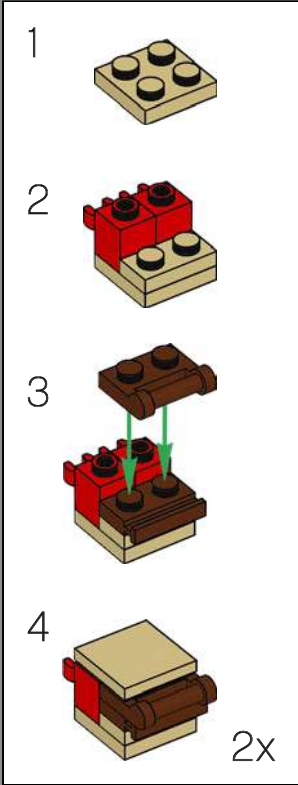

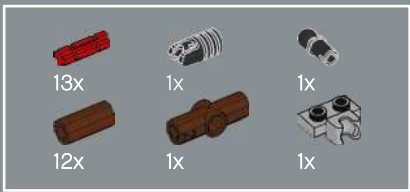

397

1

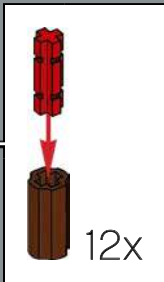
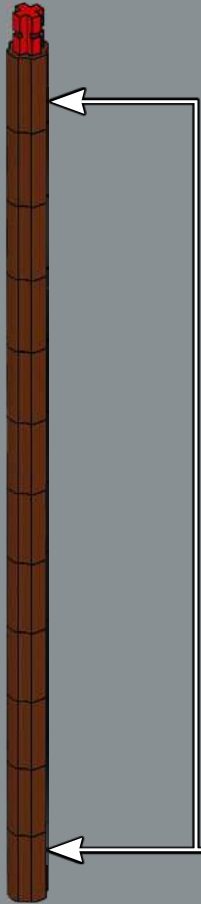

2



3

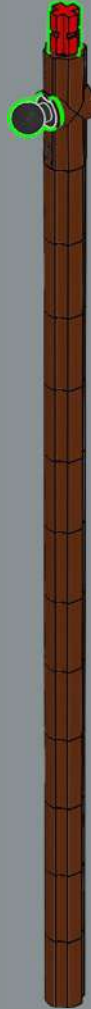

4

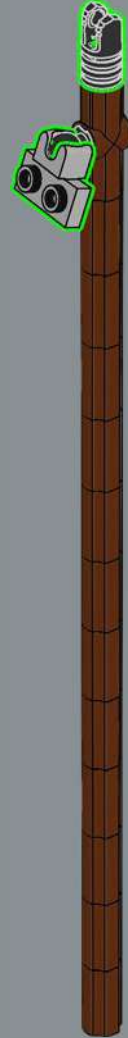

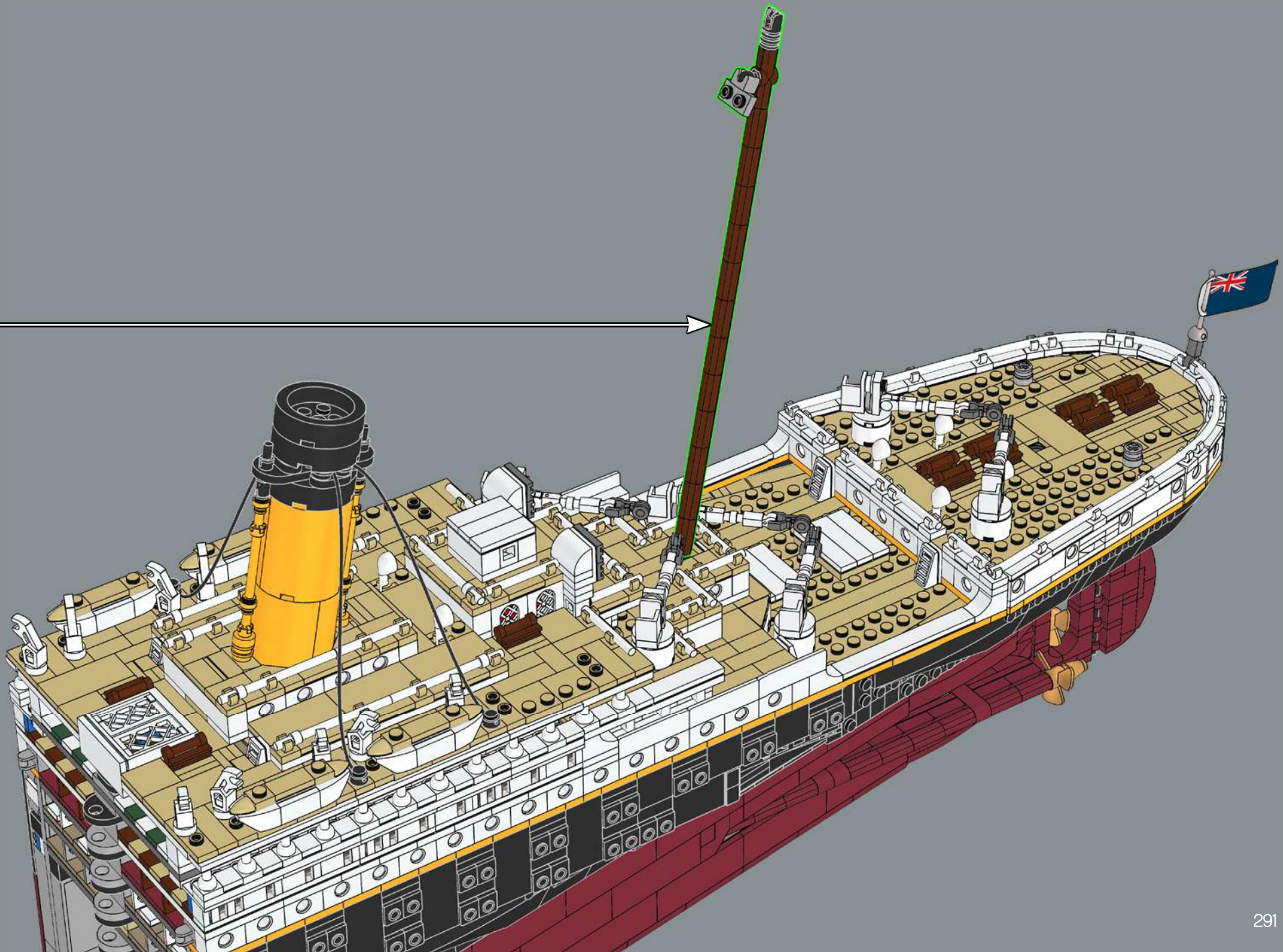

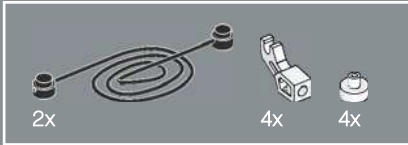
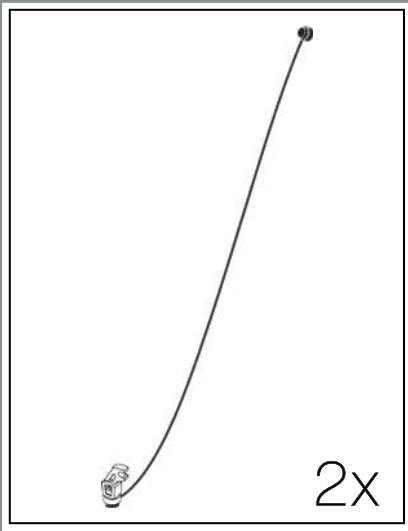

398

1

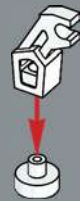

2



2x



399

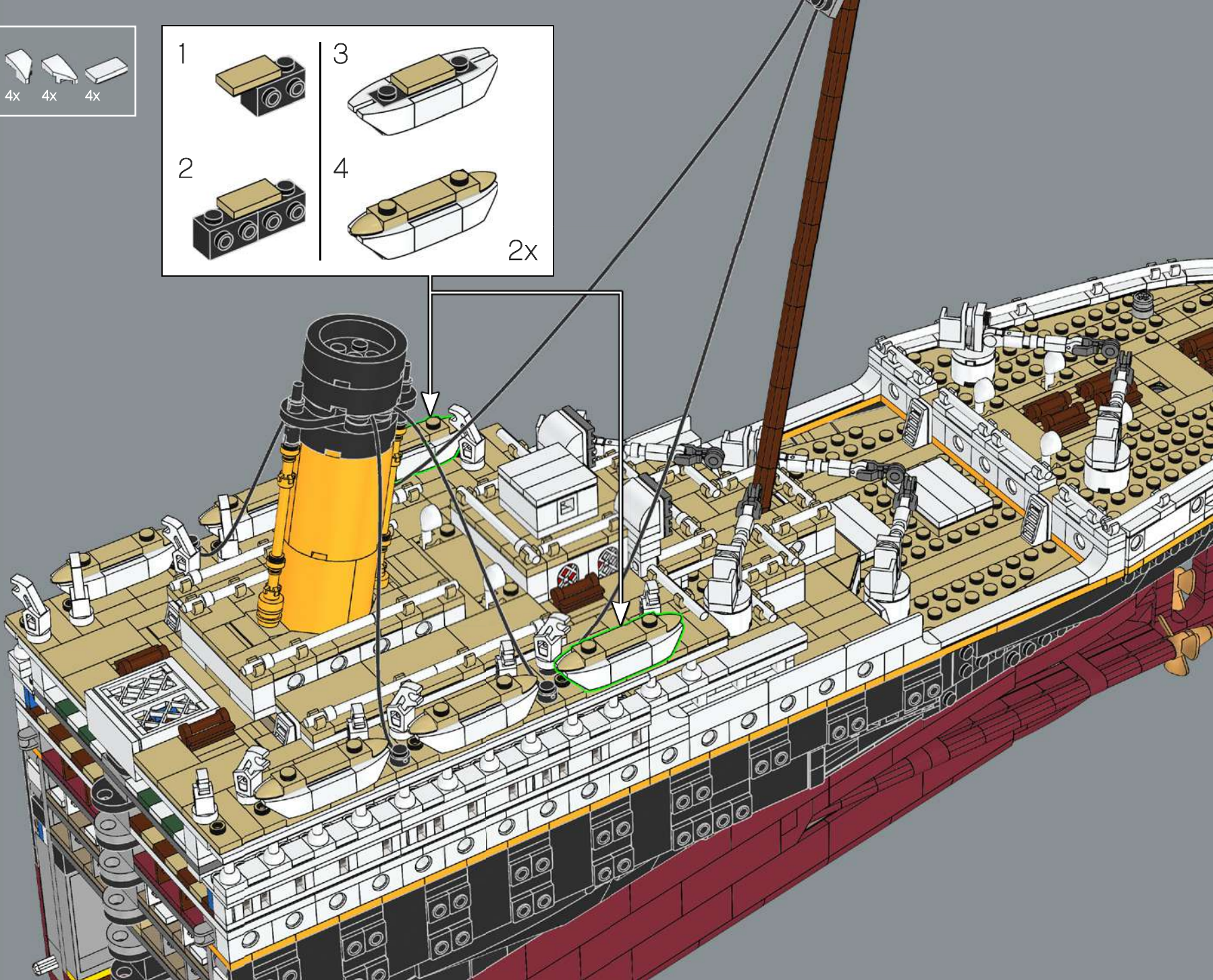
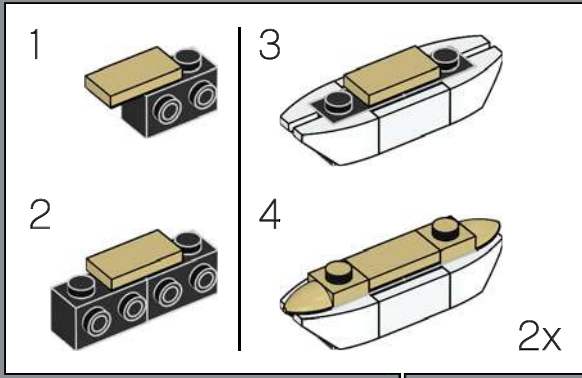

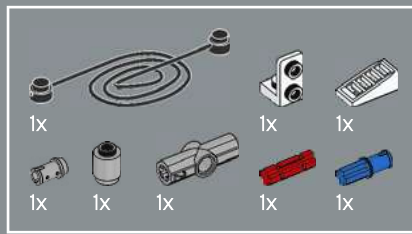

400

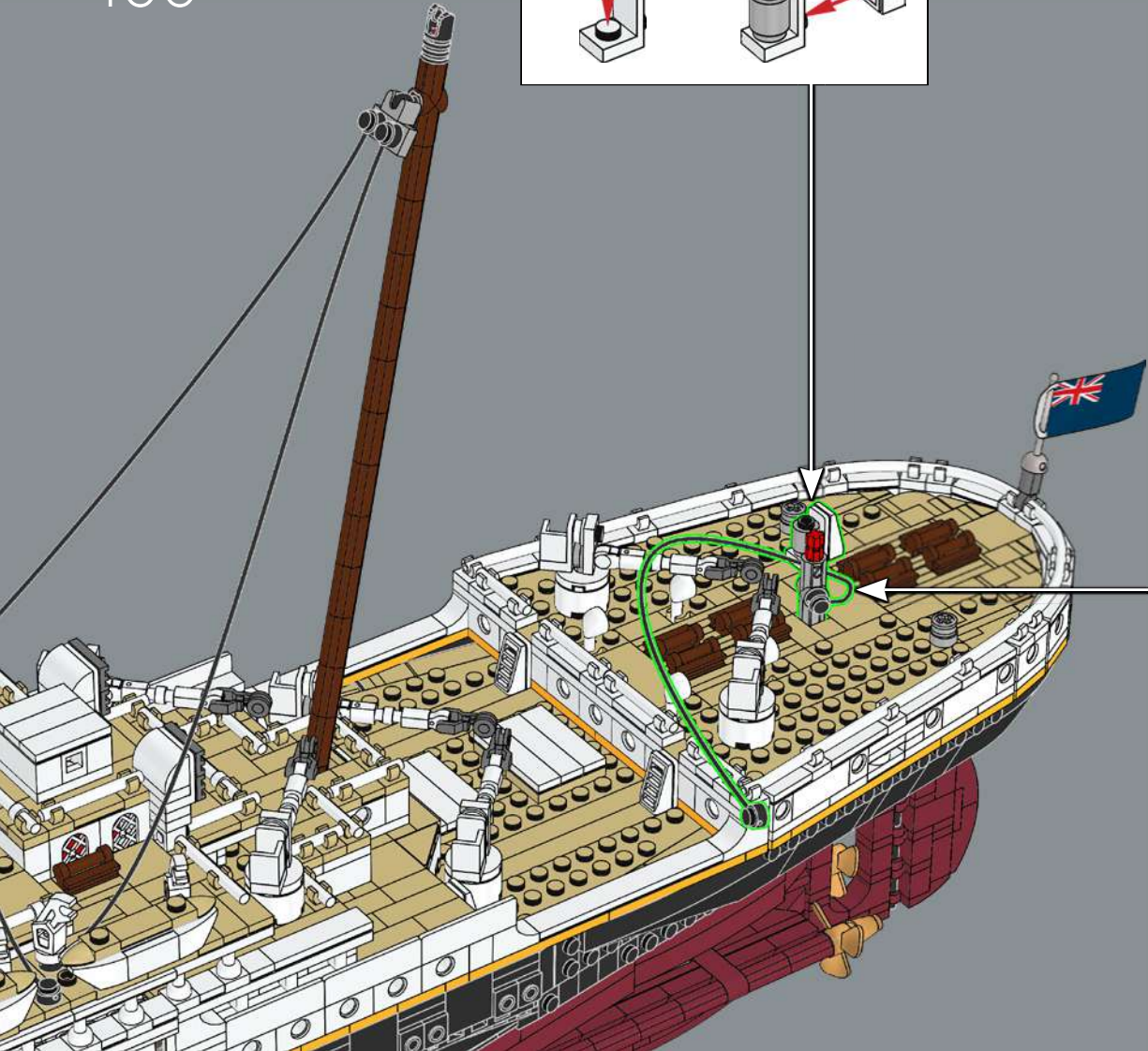
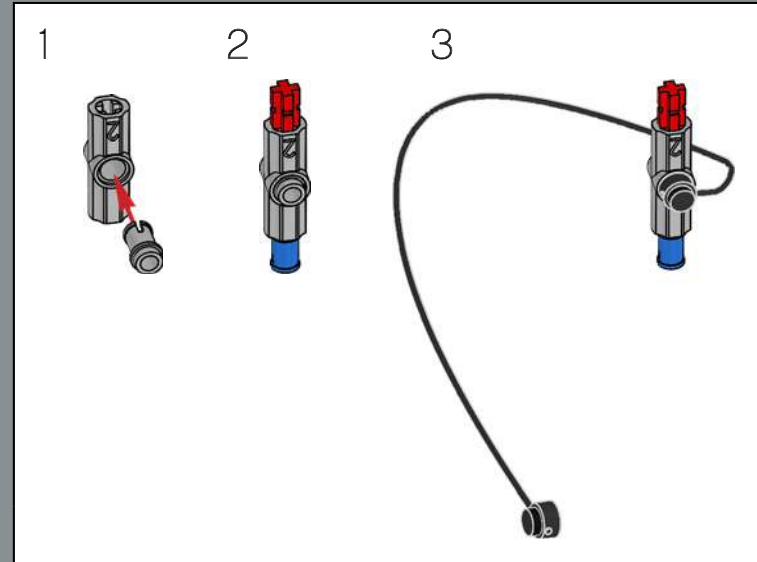
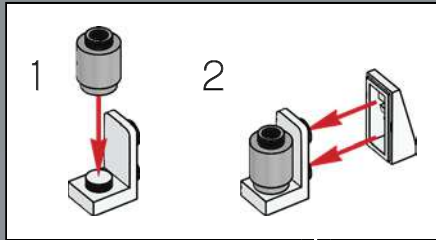



404

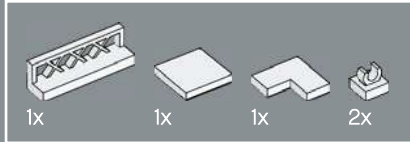
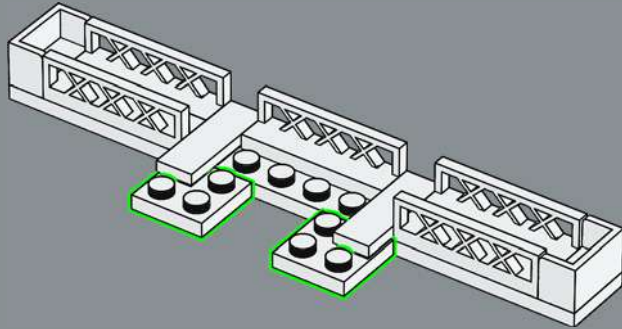

405

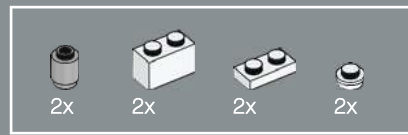
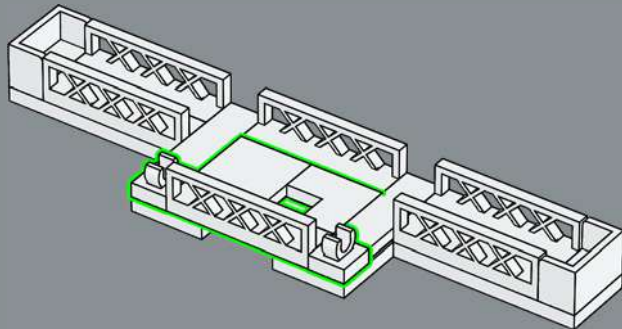

406

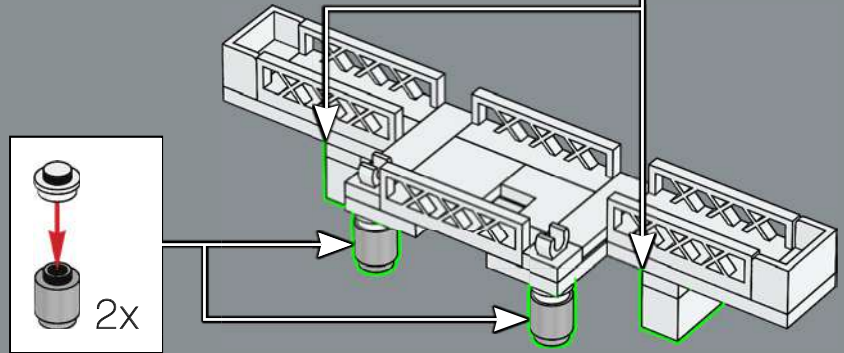

407

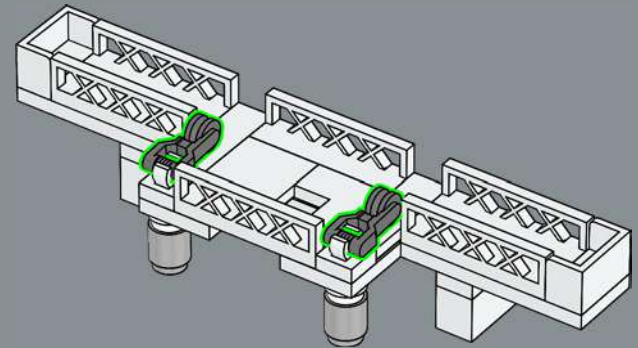



1x

408

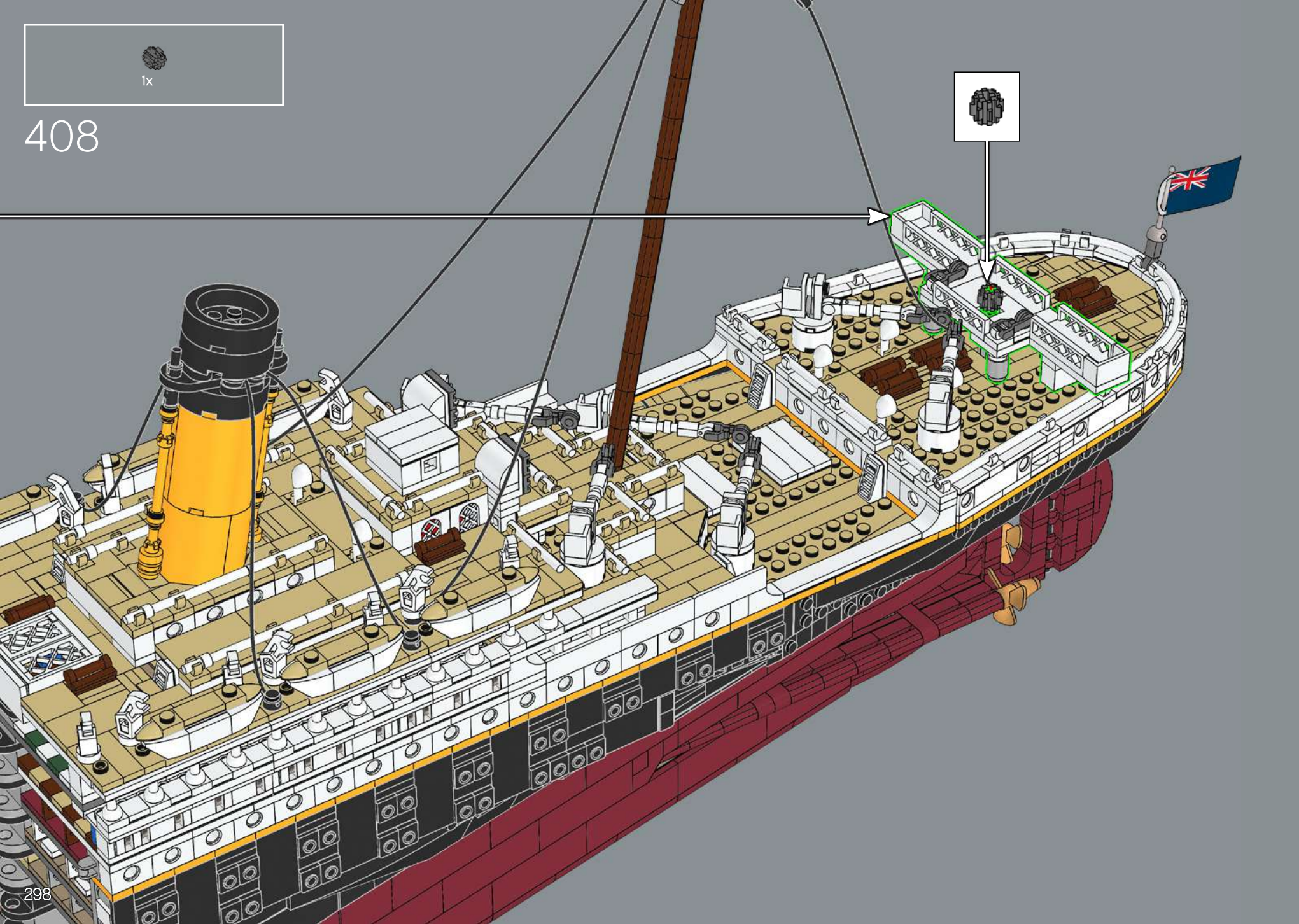



46

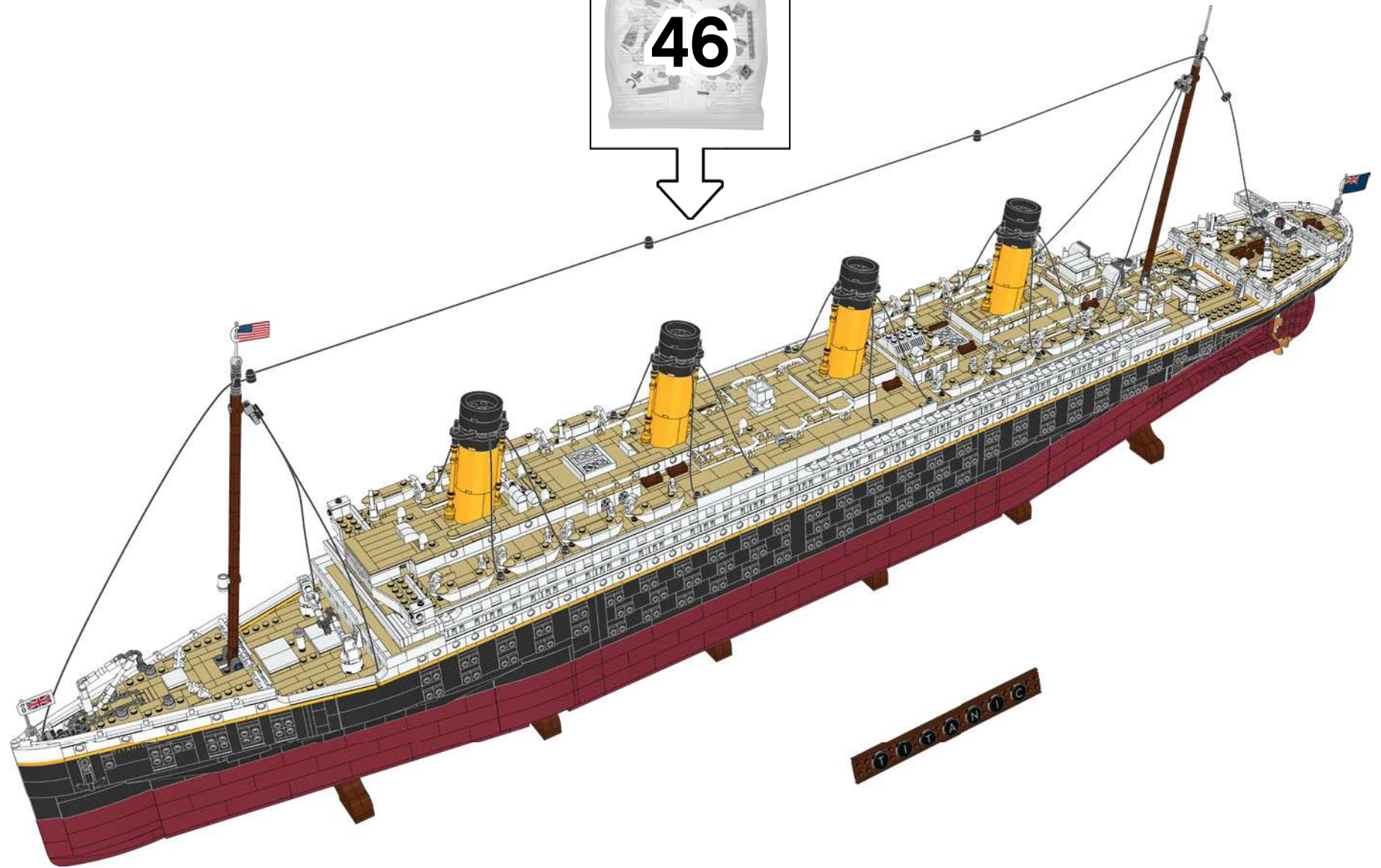

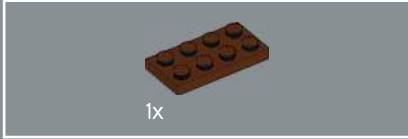
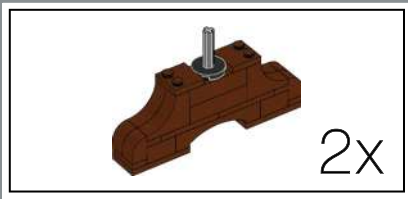

409

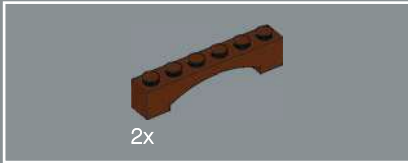

410

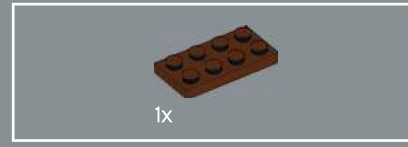
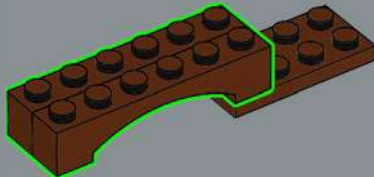

411

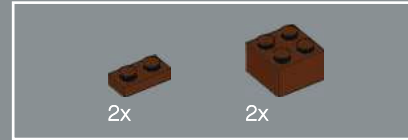
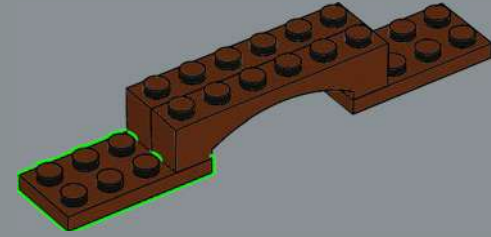

412

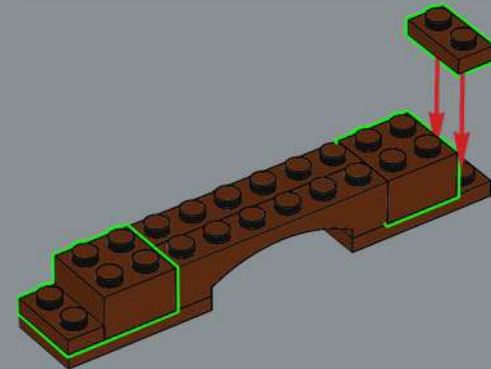

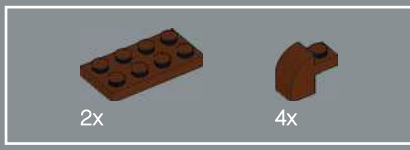

413

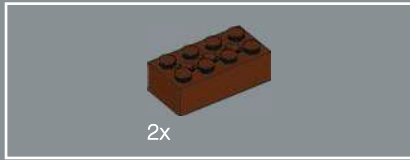
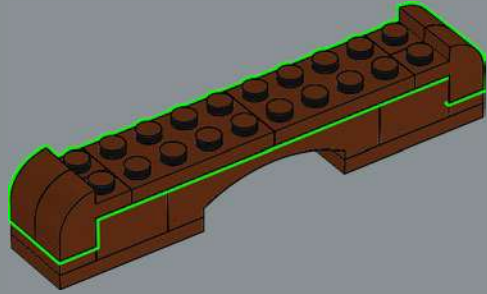

414

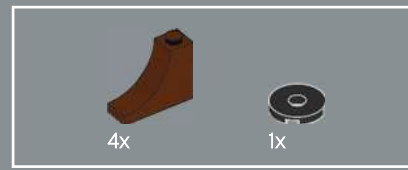
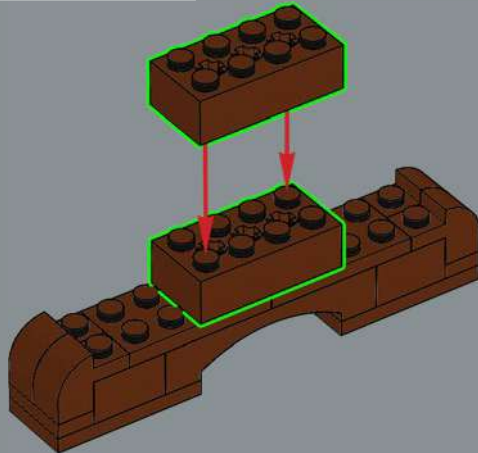

415

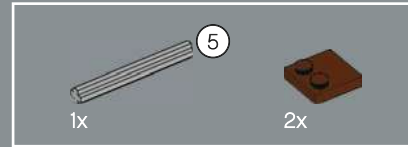
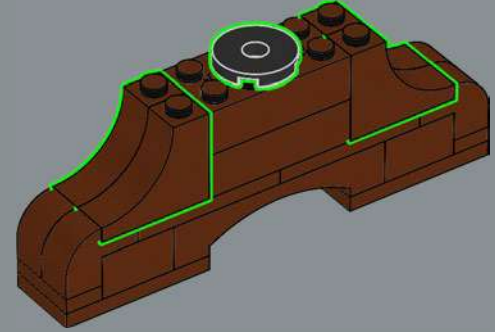

416

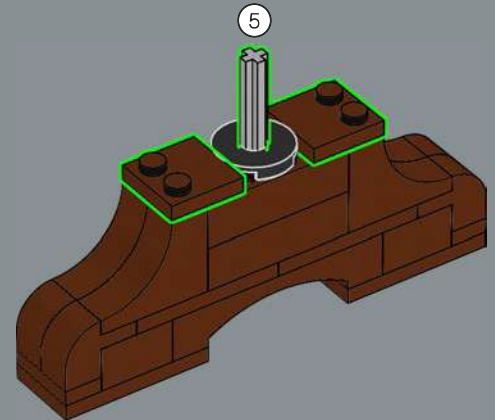

2x



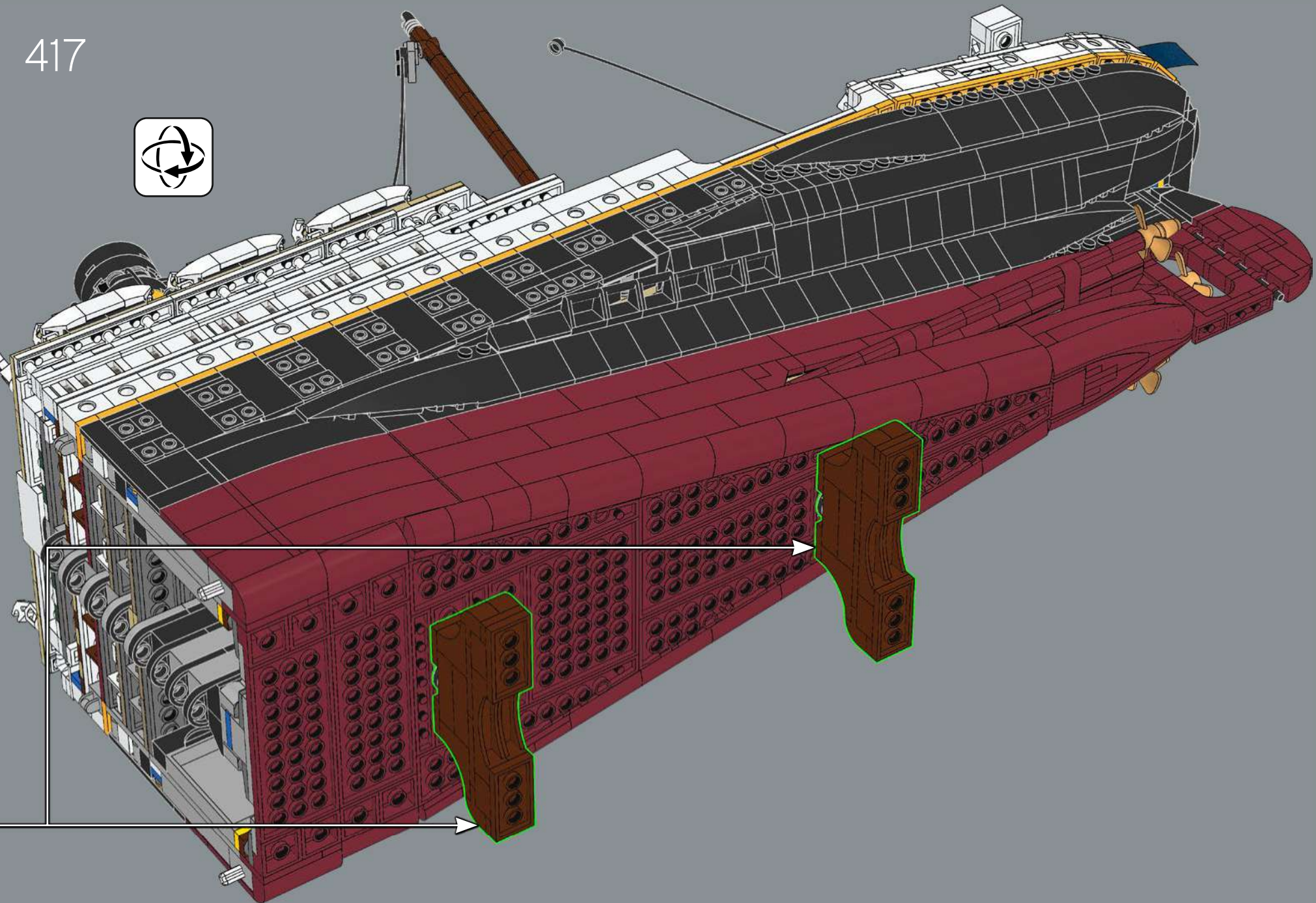

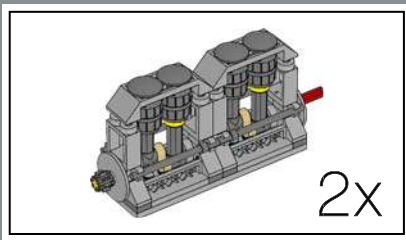

418

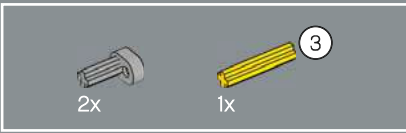

419

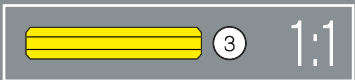
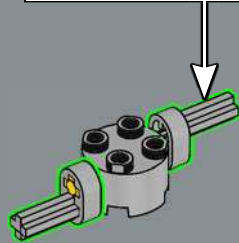
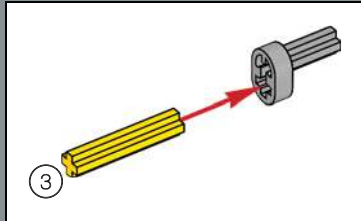

420

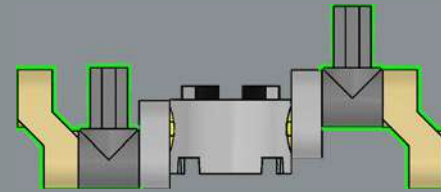

1:1

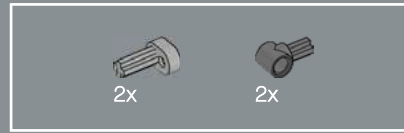

421

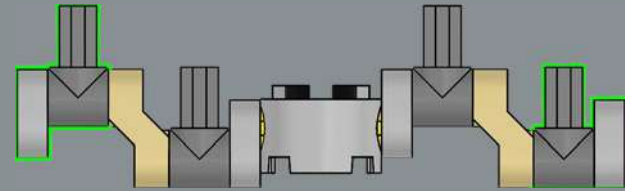

1:1

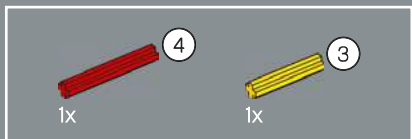

422

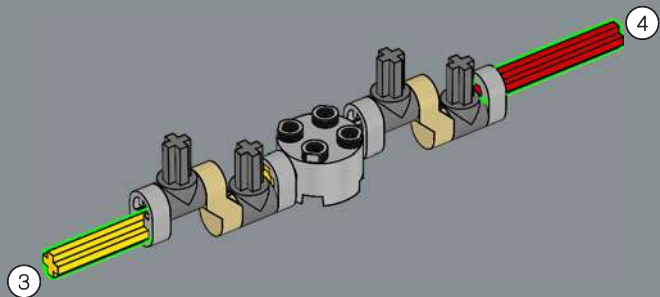

423

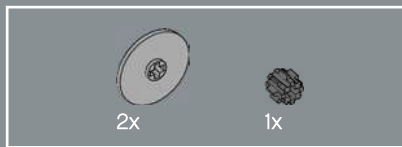
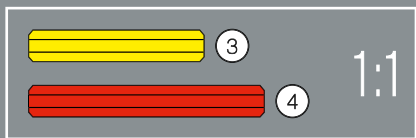
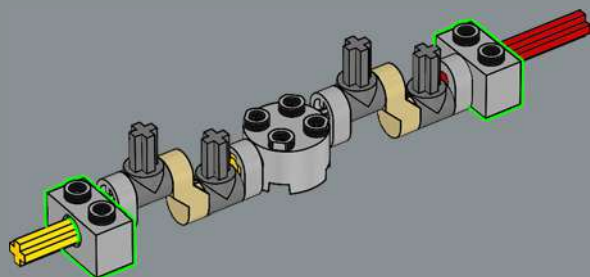

424

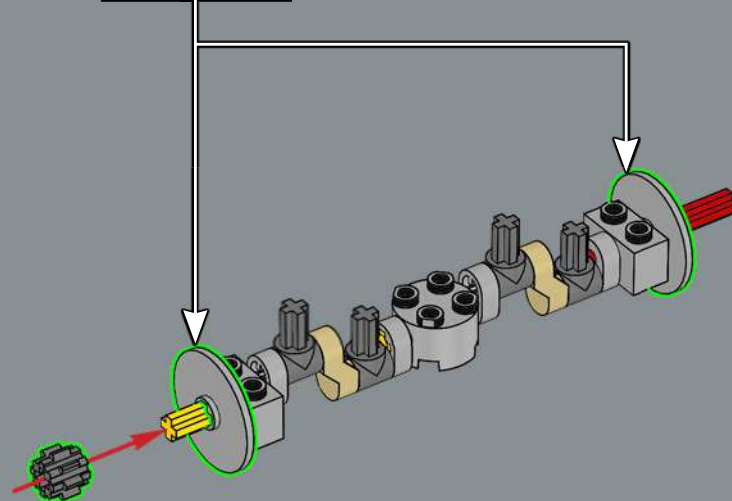
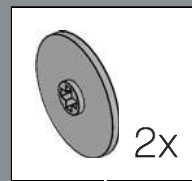

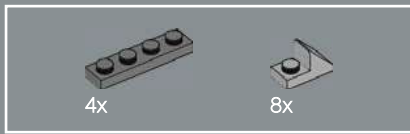

425

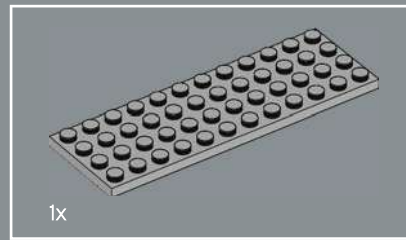
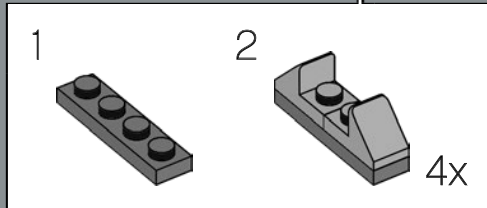
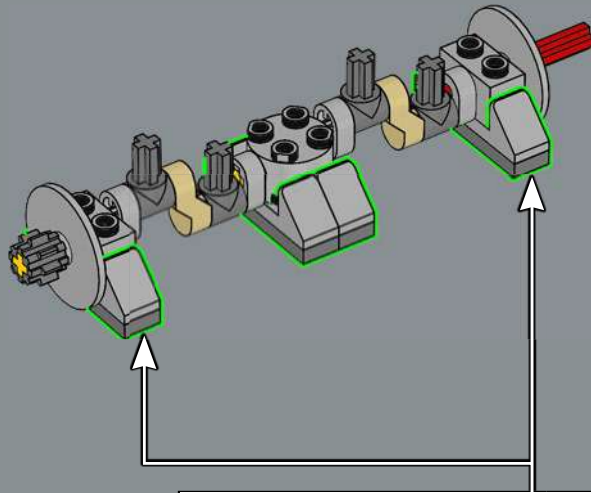

426

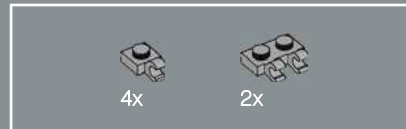
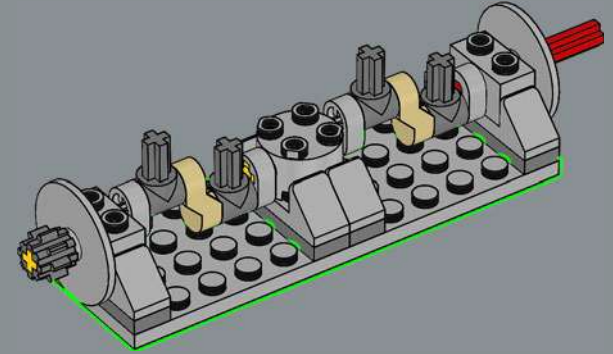

427

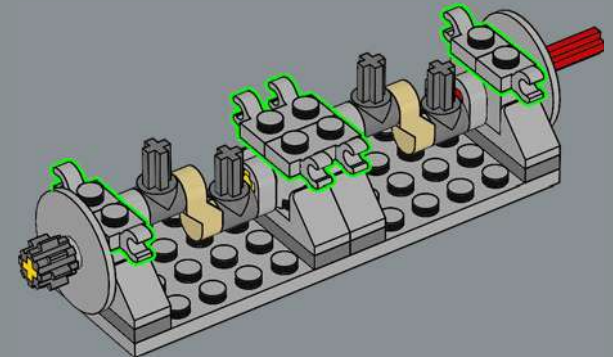

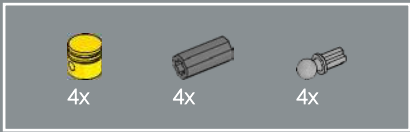

428

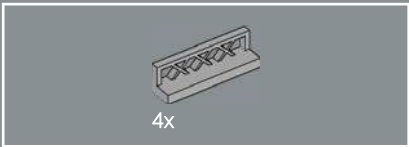
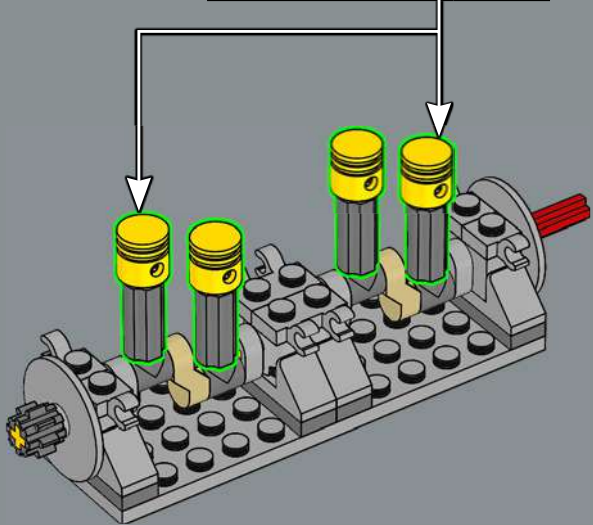
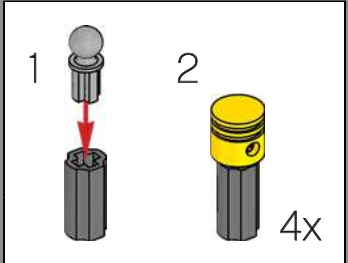

429

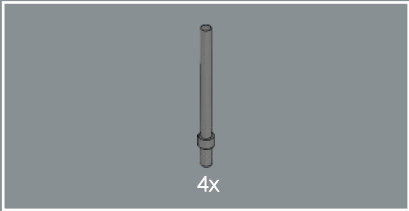
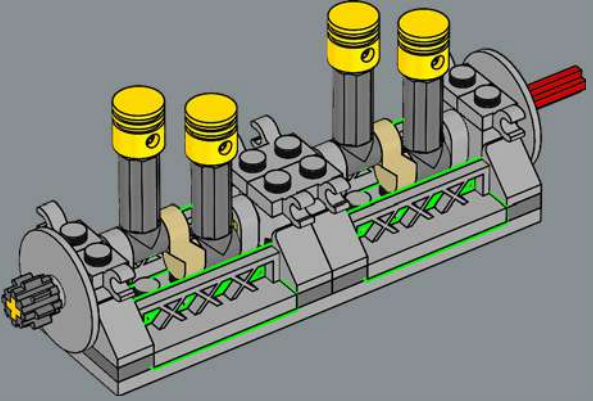

430

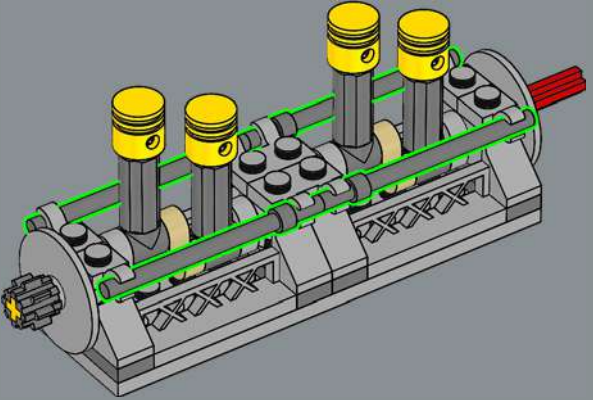



431

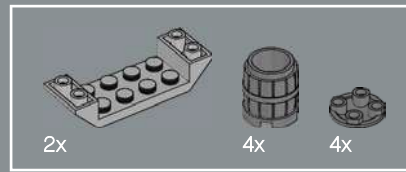
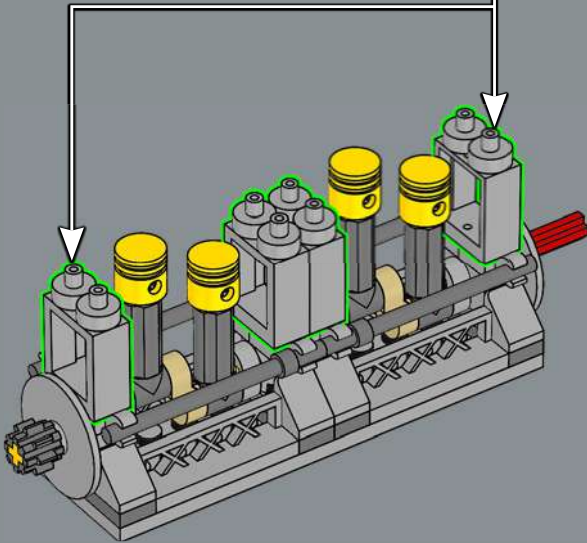
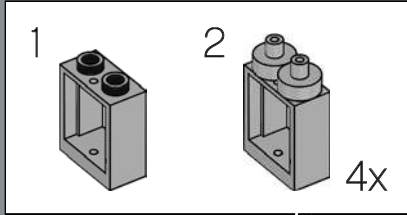

432

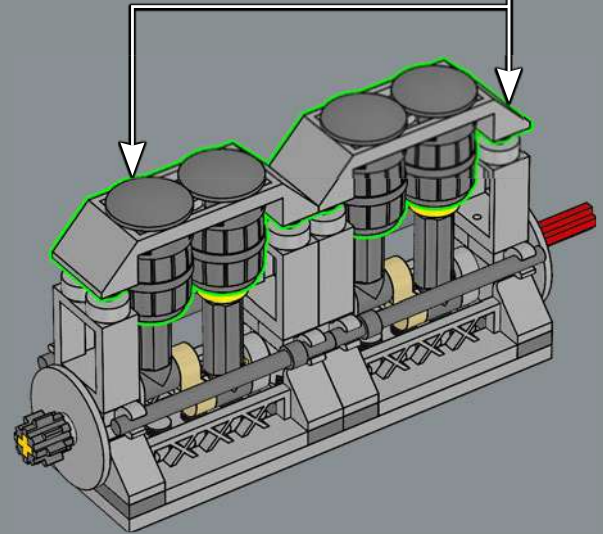
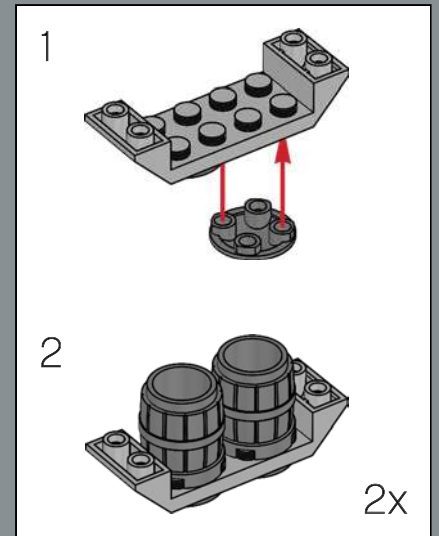

2x

433

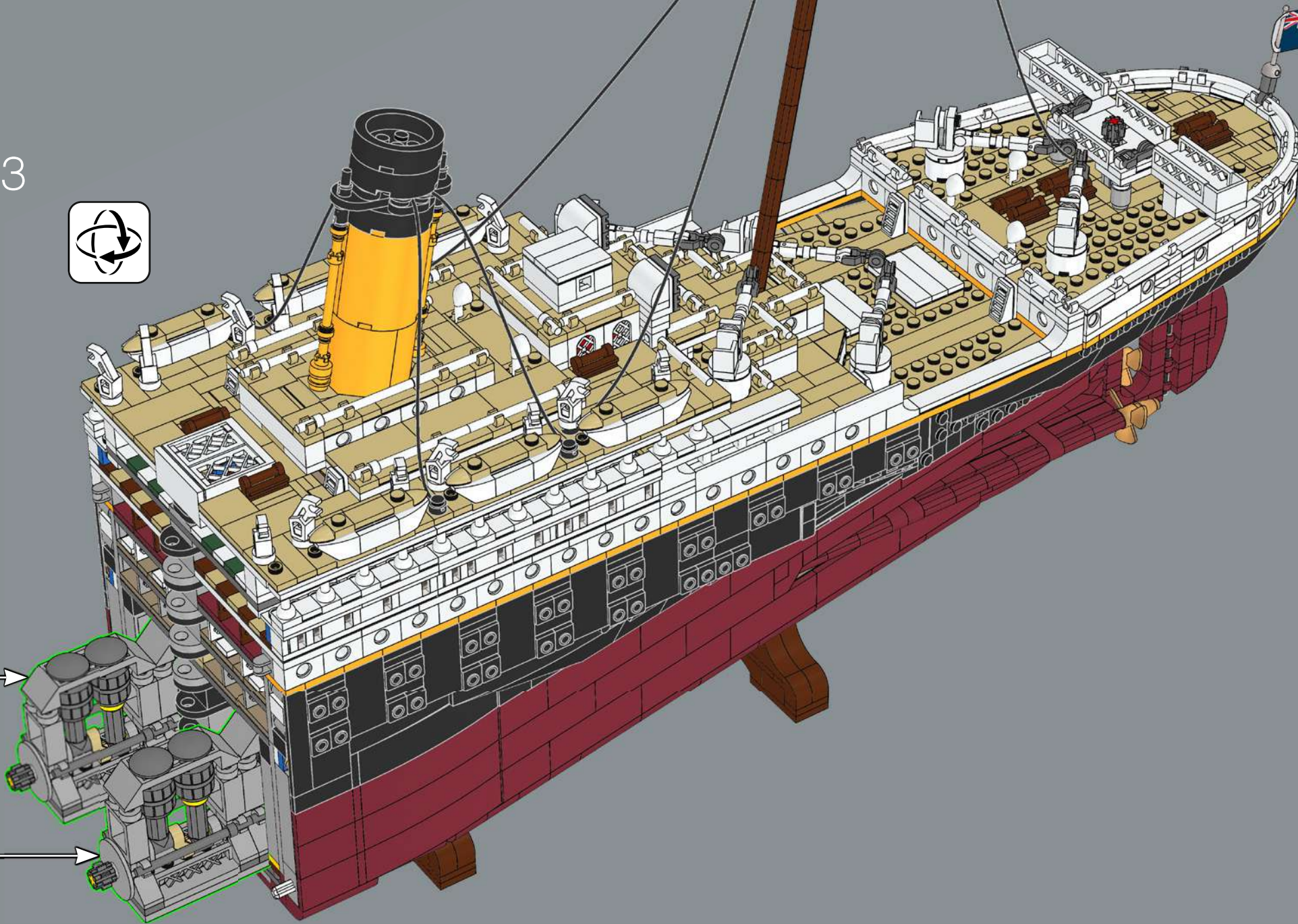

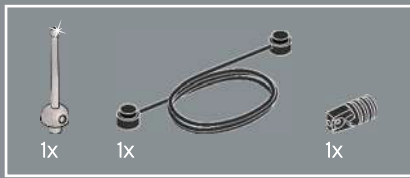

434

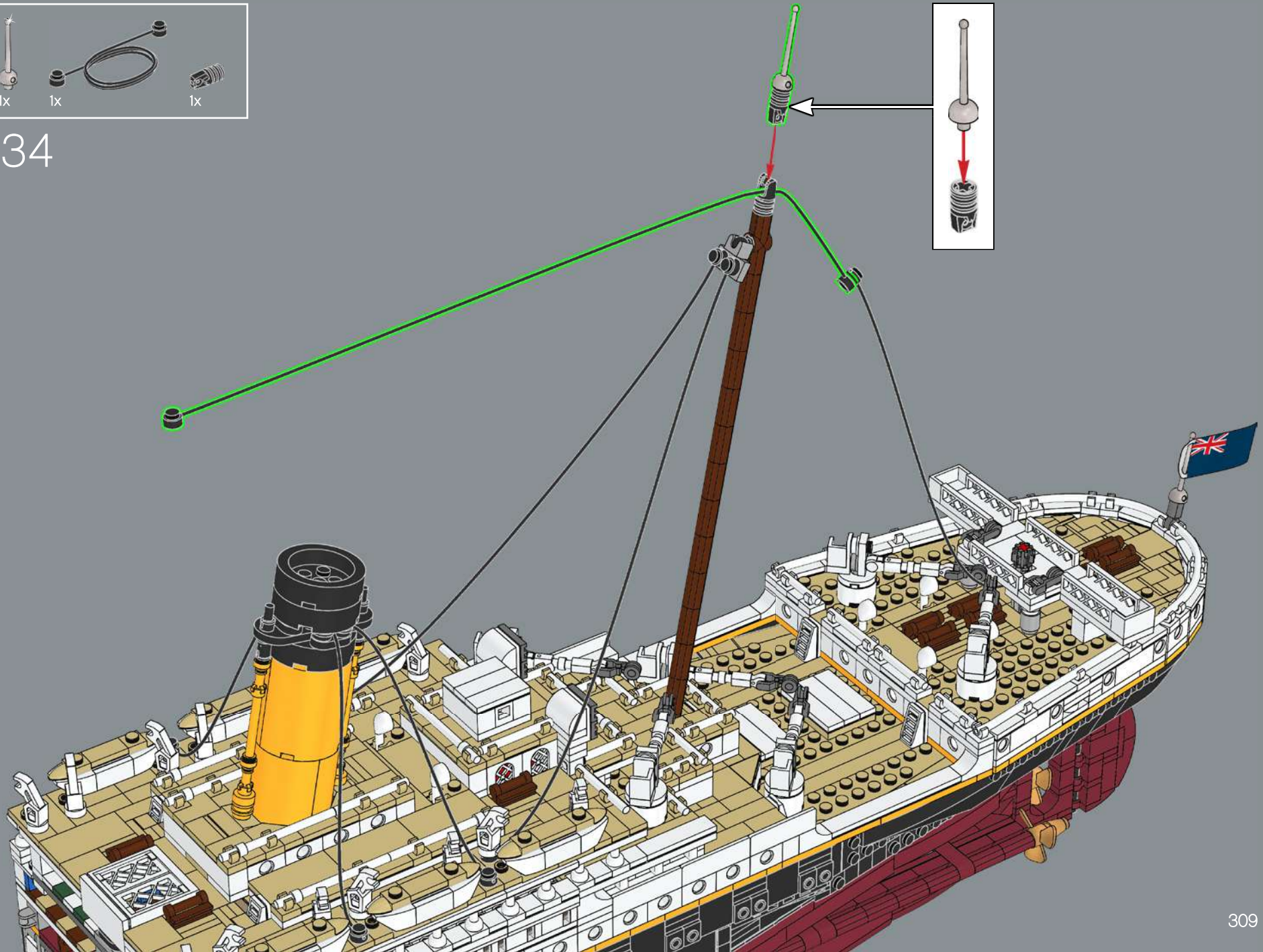

435

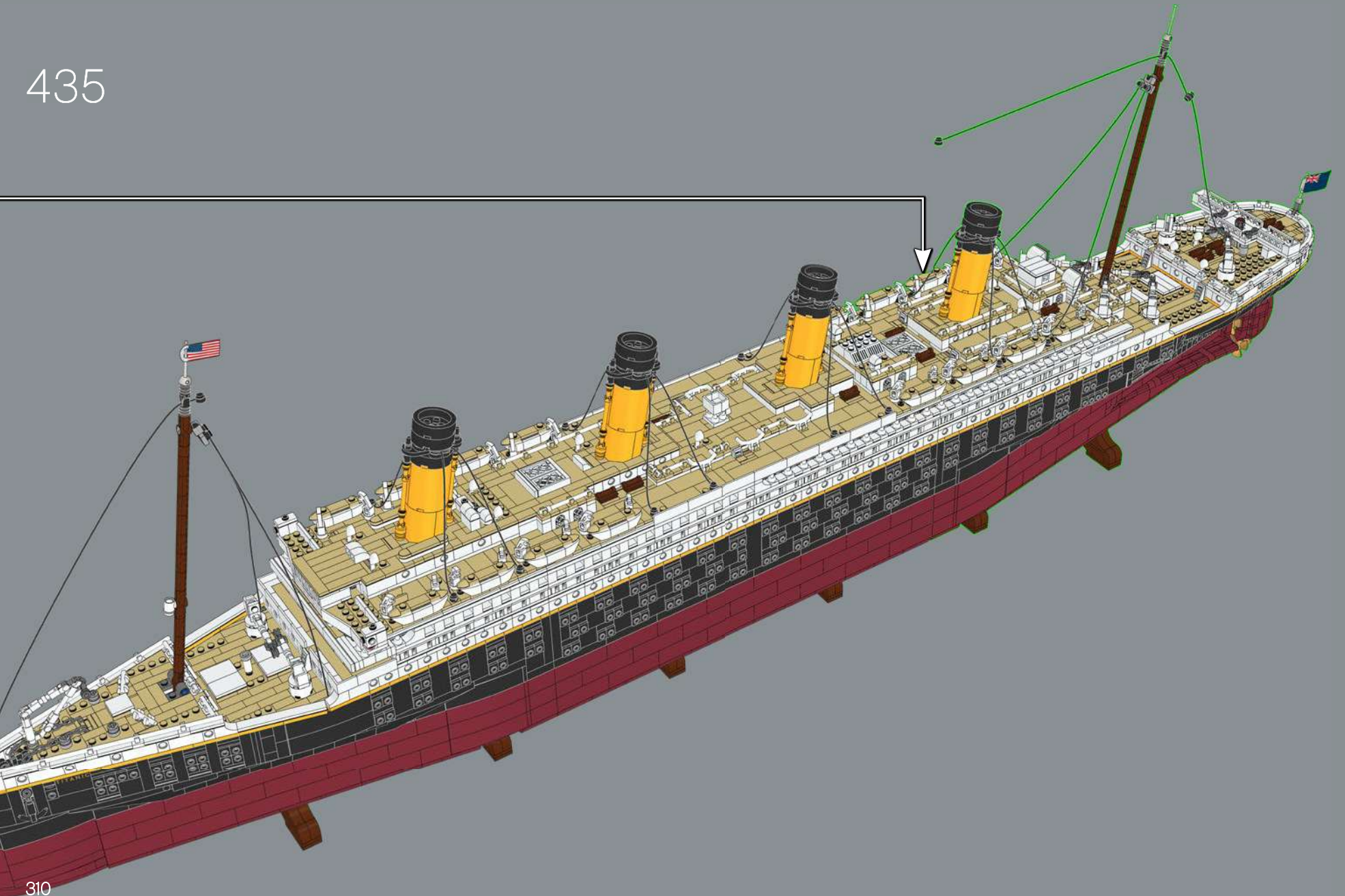

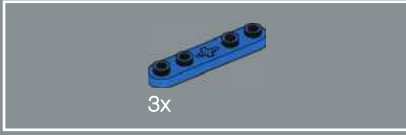
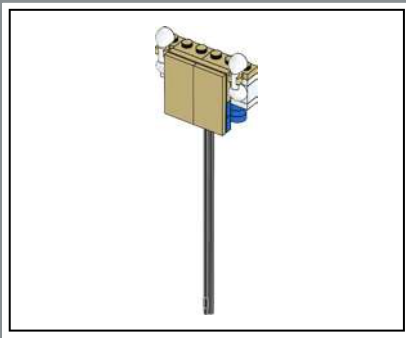

436

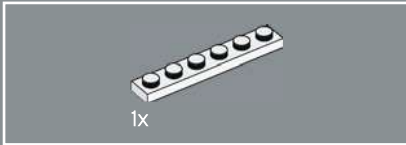
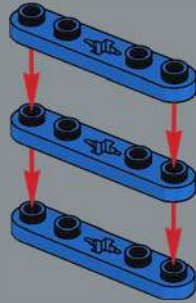

437

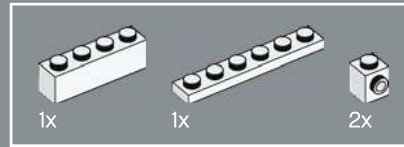
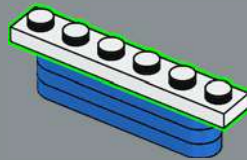

438

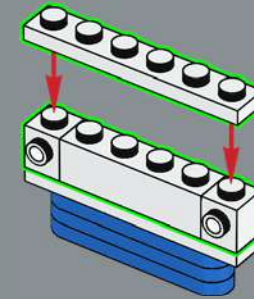

439

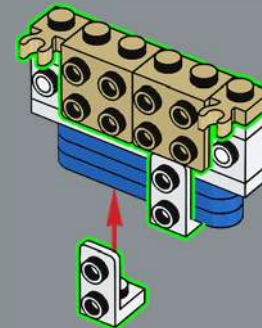

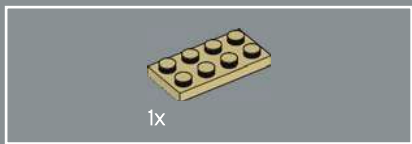

440

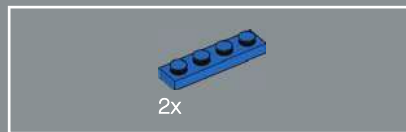
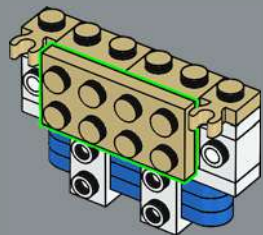

441

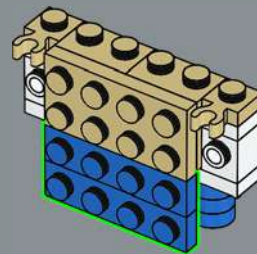

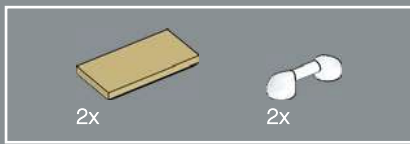

442

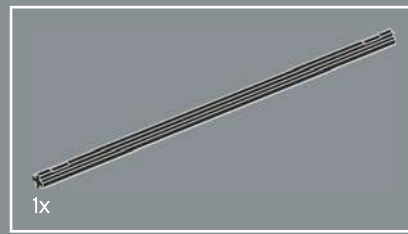
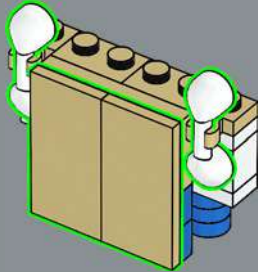

443

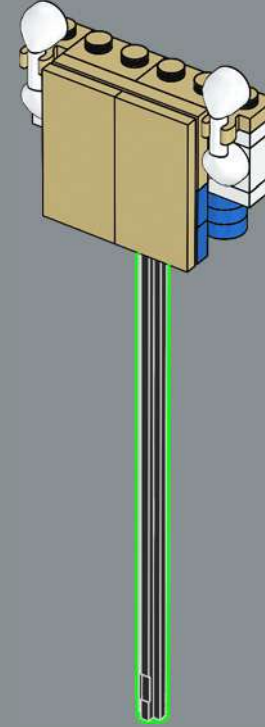

The *Titanic* was launched on the 31st of May
1911 – 110 years ago in 2021.

444

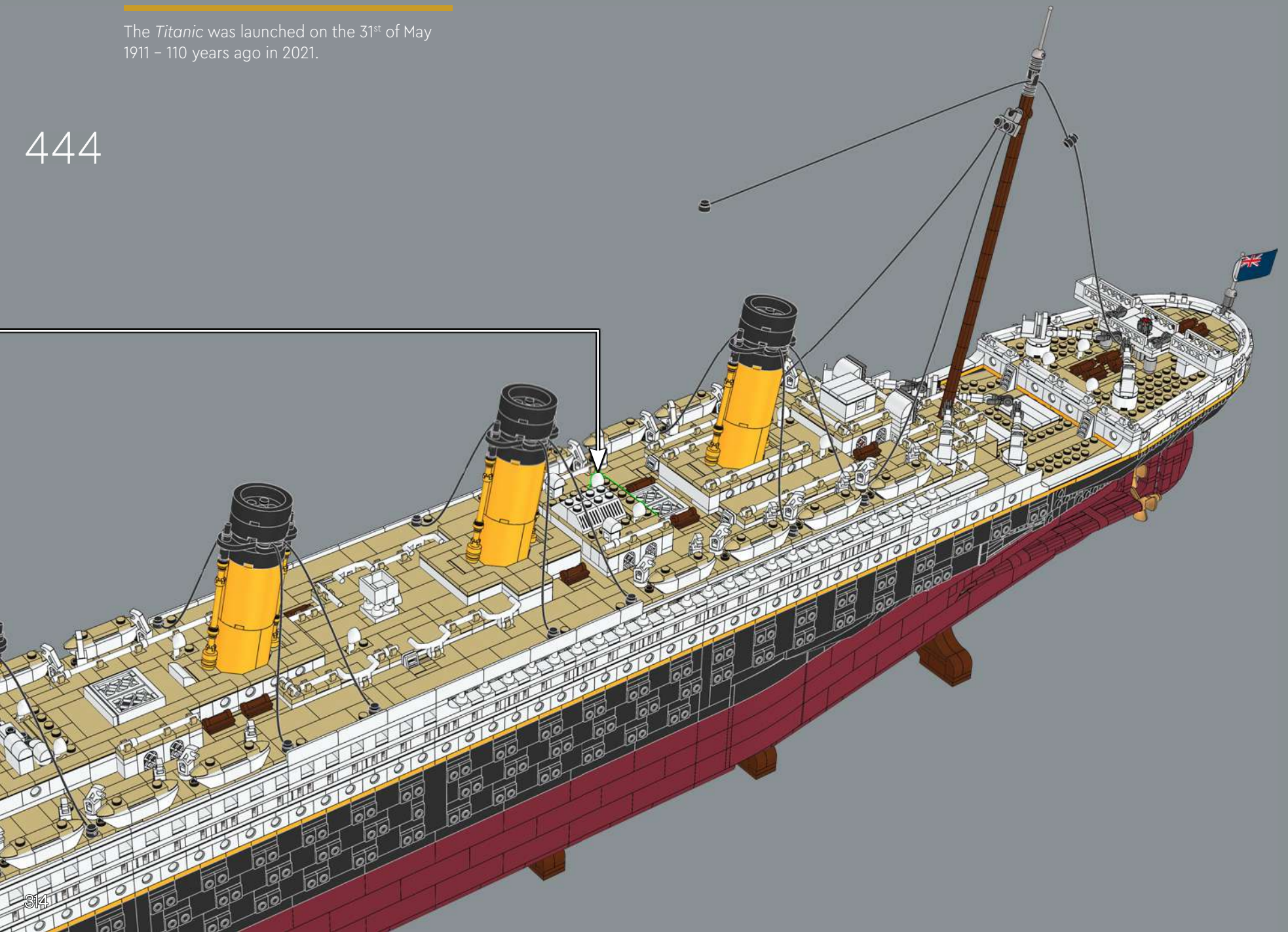

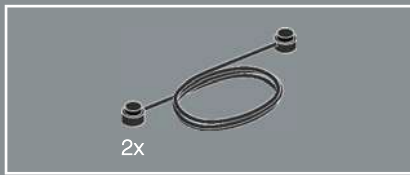

445

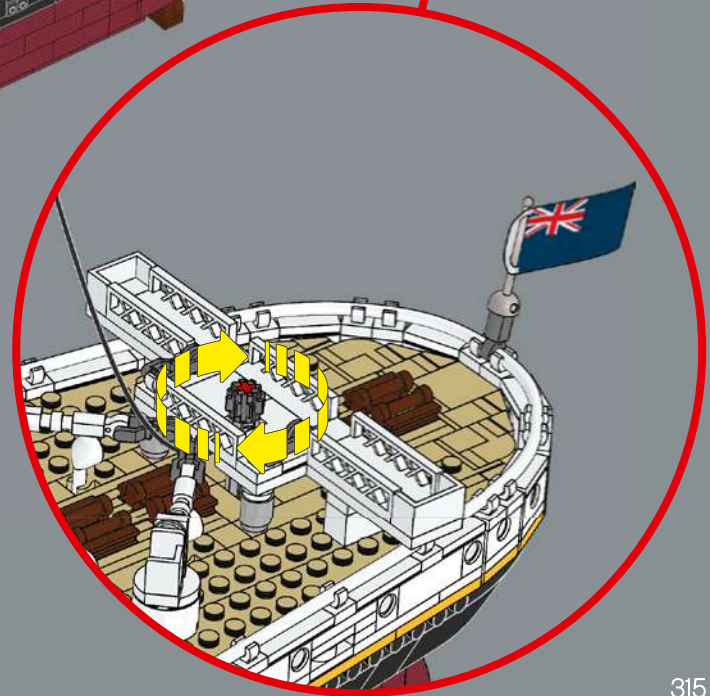
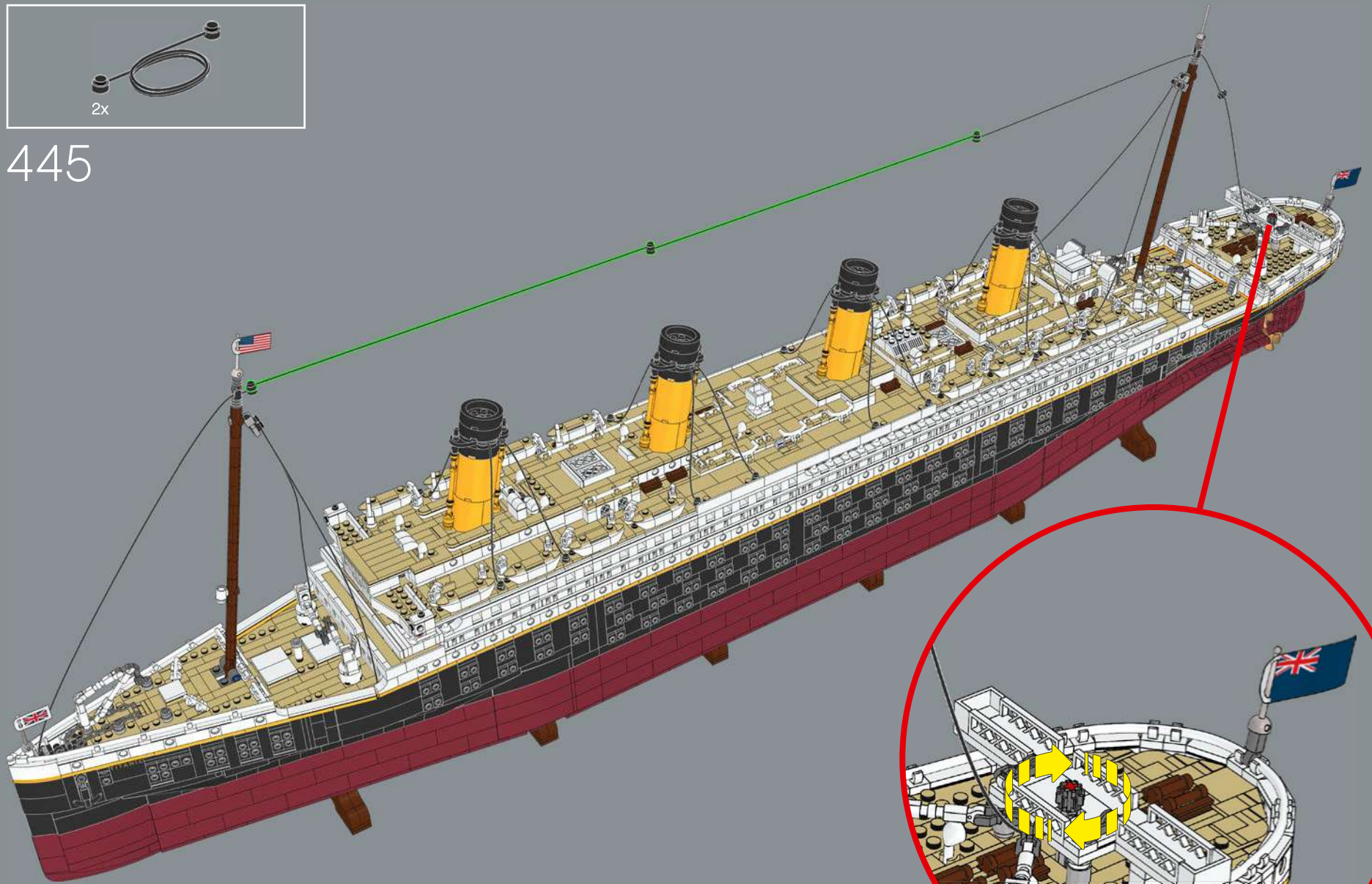

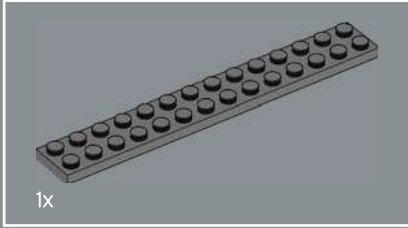
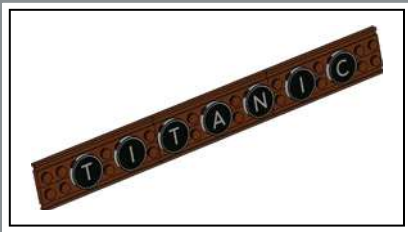

1x

446

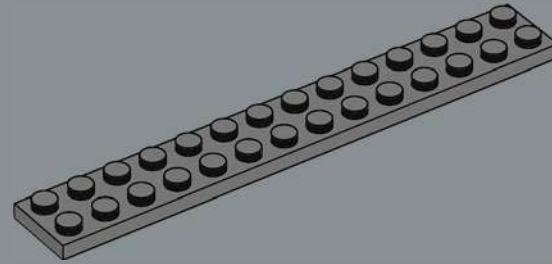

2x

447

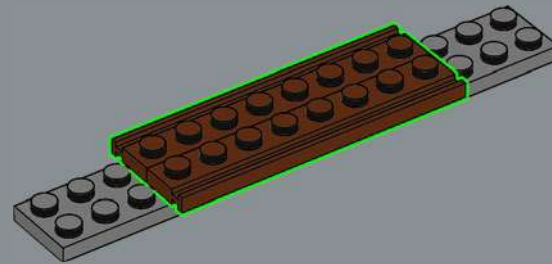



448

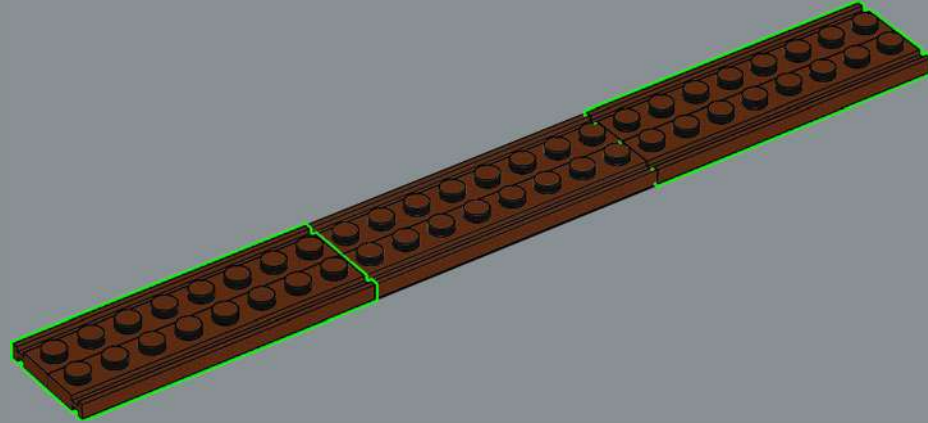

449

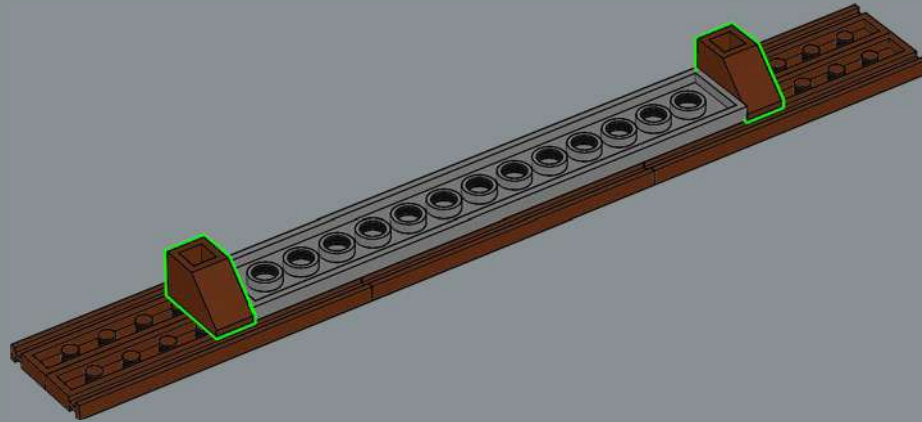



450

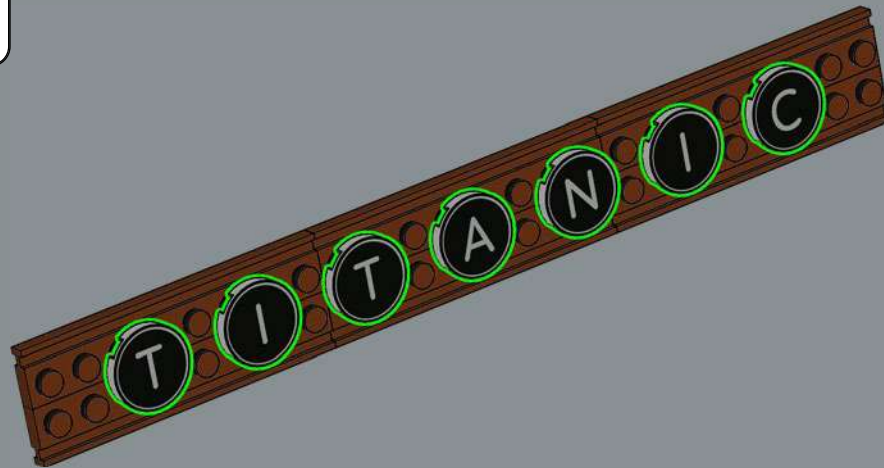

The name *Titanic* derives from the Titans of Greek mythology.

